



**DC INVERTER MULTI VRF SERVICE MANUAL**

**T1/R410A/50Hz  
(GC201207-I)**

# CONTENTS

---

---

<b>PRODUCT</b> .....	<b>2</b>
<b>1 MODELS LIST</b> .....	<b>2</b>
1.1 Outdoor Unit.....	2
<b>2 NOMENCLATURE</b> .....	<b>5</b>
2.1 Nomenclature of Outdoor Unit.....	5
<b>3 FUNCTION</b> .....	<b>5</b>
<b>4 PRODUCT DATA</b> .....	<b>6</b>
4.1 Product Data of Outdoor Unit .....	6
<b>5 PIPING DIAGRAM</b> .....	<b>16</b>
5.1 Piping diagram of GMV-Pdm224W/NaB-M,GMV-Pdm280W/NaB-M .....	16
5.2 Piping diagram of GMV-Pdm335W/NaB-M,GMV-Pdm400W/NaB-M,GMV-Pdm450W/NaB-M .....	17
<b>CONTROL</b> .....	<b>20</b>
<b>1 CONTROL OF THE UNIT</b> .....	<b>20</b>
1.1 Concept of Integral Control of the Unit.....	20
1.2 Operation Flow Chart of the Unit.....	22
1.3 Operation Flow Chart of Outdoor Unit.....	26
<b>2 WIREDLESS REMOTE CONTROLLER</b> .....	<b>28</b>
2.1 Wiredless Remote Controller Y512.....	28
2.2 Wiredless Remote Controller YB1FA .....	31
<b>3 WIRED REMOTE CONTROLLER</b> .....	<b>36</b>
3.1 Wired Controller Z60351F,Z60151F,Z63351F,Z63151F .....	36
3.2 Wired Controller XK02 .....	38
<b>4 REGIONAL CONTROLLER</b> .....	<b>42</b>
4.1 Function .....	42
4.2 Operation View .....	43
4.3 Display View .....	44
4.4 Connection Between Controller and Unit .....	45
<b>5 SMART ZONE CONTROLLER</b> .....	<b>46</b>
5.1 Function .....	46
5.2 Operation View .....	46
5.3 Display View .....	47
5.4 Network Topological Diagram.....	48
5.5 Installation and Debugging .....	49
5.6 Attachment.....	53
<b>6 CENTRALIZED CONTROLLER</b> .....	<b>54</b>
6.1 Central Control ZJ7011 .....	54
6.2 Centralized Controller CE51-24/E(M).....	57
6.3 Connection Between Controller and Unit .....	68

6.4 Case Study.....	68
<b>7 MONITORING SOFTWARE .....</b>	<b>83</b>
7.1 Remote Monitoring System.....	83
7.2 BMS System .....	83
<b>8 DETECTION CONTROL BOARD .....</b>	<b>84</b>
8.1 Gate-control Function .....	84
8.2 Working Process of Gate Control .....	84
8.3 Detection Control Board Interface Sketch is shown in Fig.2:.....	85
8.4 Products Parameters .....	85
8.5 Installation of Detection Control Board .....	85
<b>INSTALLATION.....</b>	<b>88</b>
<b>1 PRECAUTIONS FOR INSTALLATION .....</b>	<b>88</b>
1.1 Precautions for Safety .....	88
1.2 Key Points of Installation .....	89
<b>2 FLOW CHART OF INSTALLATION .....</b>	<b>90</b>
<b>3 INSTALLATION OF OUTDOOR UNIT .....</b>	<b>91</b>
3.1 Hoisting of Unit .....	91
3.1 Installation of Outdoor Unit with Side Air Outlet.....	92
3.2 Selection of Installation Site .....	92
3.3 Dimensions Data .....	93
3.4 Clearance Data .....	94
3.5 Take Monsoons and Snow into Consideration .....	96
<b>4 INSTALLATION REQUIREMENTS OF REFRIGERANT PIPING .....</b>	<b>97</b>
4.1 Specification .....	97
4.2 Allowable Length and Height Differences of the Refrigerant Piping between the Indoor and Outdoor Units .....	97
4.3 Refrigerant Pipe Size .....	99
4.4 Selection of Y-Type Branch Pipe .....	99
4.5 Selection of Refrigerant Piping between Outdoor Unit and Outdoor Unit ( for module unit) .....	100
4.6. Outdoor unit piping sequence diagram.....	101
4.7 Design requirements for oil trap.....	102
<b>5 INSTALLATION OF REFRIGERANT PIPING .....</b>	<b>104</b>
5.1 Flow Chart of Installation .....	104
5.2 Three Principles of Refrigerant Piping Installation .....	105
5.3 Installation of Metal Embedded Pipe.....	105
5.4 Installation of Carriage of Refrigerant pipin .....	105
5.5 Management and Machining of Refrigerant Piping .....	106
5.6 Installation of Refrigerant Piping.....	110
5.7 Welding of Copper Pipe.....	112
5.8 Cleaning of Refrigerant Piping .....	116
5.9 Pressure Maintaining and Leak Hunting .....	117

5.10 Heat Preservation of Refrigerant Piping .....	119
5.11 Vacuum Pumping .....	120
5.12 Refrigerant Charge .....	121
<b>6 INSTALLATION OF CONDENSATE PIPE .....</b>	<b>123</b>
6.1 Material Quality Requirements for Condensate Pipe .....	123
6.2 Key Points for Condensate Pipe Installation.....	123
6.3 Test for Condensate Pipe .....	126
6.4 Requirements of Heat preservation .....	126
<b>7 ELECTRICAL INSTALLATION .....</b>	<b>127</b>
7.1 Precautions for Electrical Installation.....	127
7.2 Specifications Of Power Cord & Circuit Breaker .....	127
7.3 Wiring Sketch Map .....	128
7.4 Dial-up of Unit.....	137
<b>ENGINEERING DEBUGGING .....</b>	<b>143</b>
<b>1 NECESSITY OF ENGINEERING DEBUGGING FOR VRF UNITS.....</b>	<b>143</b>
<b>2 ILES AND TOOLS FOR ENGINEERING DEBUGGING .....</b>	<b>143</b>
2.1 Tools .....	143
2.2 Debugging Files .....	143
<b>3 STEPS OF ENGINEERING DEBUGGING.....</b>	<b>143</b>
3.1 Preparation before Debugging .....	143
3.2 Inspection before Debugging .....	144
3.3 Debugging .....	149
3.4 Debugging of Cooling Mode .....	151
3.5 Running of Heating Mode.....	154
3.6 When the debugging is finished, sort out and save the data. Record the trouble and troubleshooting during the debugging for future reference. Then, make a debugging report and turn over it to users.....	154
<b>4. MAIN PARAMETERS AND REFERENCE VALVES FOR DEBUGGING .....</b>	<b>155</b>
<b>5 COMMON TROUBLES DURING DEBUGGING .....</b>	<b>157</b>
5.1 Communication .....	157
5.2 System .....	160
<b>6 PORTABLE DEBUGGER.....</b>	<b>166</b>
6.1. Function Introduction .....	166
6.2 Display and Button .....	166
6.3 Debugger Connection.....	167
<b>MAINTENANCE .....</b>	<b>169</b>
<b>1 TROUBLE SHOOTING .....</b>	<b>169</b>
1.1 Trouble Display of Indoor Unit.....	169
1.2 Trouble Display of Mainboard LED of Outdoor Unit.....	170
<b>2 FLOW CHART OF TROUBLESHOOTING .....</b>	<b>182</b>
2.1 High-pressure Protection .....	182



2.2 Low-pressure Protection .....	184
2.3 Exhaust Temperature Protection .....	186
2.4 Communication Failure .....	187
2.5 Temperature sensor Trouble .....	188
2.6 Sensor Trouble .....	189
2.7 No energization to the unit and mainboard .....	190
2.8 The AC contactor does not pull in .....	191
2.9 Typical troubleshooting (E5) for DC frequency conversion drive board .....	192
2.10 E5 Protection .....	197
2.11 PFC Protection .....	199
2.12 IPM Protecion .....	200
2.13 Trip.....	201
2.14 Superheat Protection of Radiator .....	202
2.15 DC Overvoltage Protection .....	203
<b>3 POWER DISTRIBUTION .....</b>	<b>204</b>
3.1 Diagram of Power Distribution .....	204
3.2 Introduction of Main Electric Parts of Inverter System .....	204
3.3 Wiring diadram .....	205
<b>4 TABLE OF THE RESISTANCES OF COMMON TEMPERATURE SENSORS .....</b>	<b>207</b>
4.1. 15k $\Omega$ .....	207
4.2. 20k $\Omega$ .....	209
4.3. 50k $\Omega$ .....	211
<b>5 FEATURES OF THE HIGHT/LOW PRESSURE SENSORS.....</b>	<b>213</b>
5.1 Features of the High Pressure Sensors (R410a).....	213
5.2 Features of the Low Pressure Sensors (R410a).....	214
<b>6 AFTER-SALES EMERGENCY MEASURES .....</b>	<b>215</b>
<b>7 DISASSEMBLY AND ASSEMBLY PROCEDURE OF MAIN PARTS .....</b>	<b>216</b>
7. 1 Outdoor Unit .....	216
<b>8 EXPLODED VIEWS AND PART LIST .....</b>	<b>226</b>
8.1 Outdoor Unit .....	226





























# PRODUCT

## PRODUCT





















### 1 MODELS LIST

#### 1.1 Outdoor Unit



Model	Product Code	Cooling Capacity	Heating Capacity	Power supply	Appearance
		kW	kW		
GMV-Pdm224W/NaB-M	CN851W1000	22.4	25.0	380~415V-3Ph~50Hz	
GMV-Pdm280W/NaB-M	CN851W1010	28.0	31.5	380~415V-3Ph~50Hz	
GMV-Pdm335W/NaB-M	CN851W1020	33.5	37.5	380~415V-3Ph~50Hz	
GMV-Pdm400W/NaB-M	CN851W1030	40.0	45.0	380~415V-3Ph~50Hz	
GMV-Pdm450W/NaB-M	CN851W1040	45.0	50.0	380~415V-3Ph~50Hz	

Appearance	Model		GMV-Pdm***W/NaB-M						
			224	280	335	400	450		
	GMV-Pdm***W2/NaB-M	504							
		560							
		615							
		670							
		730							
		785							
		850							
		900							
			GMV-Pdm***W3/NaB-M	950					
				1008					
	1065								
	1130								
	1180								
	1235								
	1300								
	1350								
									



Appearance	Model	GMV-Pdm***W/NaB-M				
		224	280	335	400	450
	1405					
	1456					
	1512					
	1570					
	1650					
	1700					
	1750					
	1800					

**NOTES:**

- “” represents one module and “... (1...N)” represents N modules.
- “\*” indicates the rated cooling capacity.
- Design of this unit accords with the Standard GB/T 18837-2002.
- Noise was tested in semi-silenced room, so the actual noise value will be a little higher for change of environment..
- The charge amount of R410A in the list is only the sealed amount when outdoor unit is outgoing. When installing, calculate
  - the additional charge amount according to actual length of pipe and the matched indoor units;
  - Nominal capacities are based on the following conditions.



**CAUTIONS**

It is not recommended to adopt the combination mode not specified by this manual.

## 2 NOMENCLATURE

### 2.1 Nomenclature of Outdoor Unit

GMV □ - □ 224 W □ / Na B - □  
 1 2 3 4 5 6 7 8 9

NO.	Description	Options
1	Code for type	GMV: Gree Multi Variable
2	Code for model	L: Cooling Only, Default: Heat pump
3	Units Series	Pdm: Modular D.C. Inverter Multi-variable
4	Nominal cooling capacity	224: 22.4 kW.....450:45.0kW
5	Outdoor unit	W: Outdoor unit
6	Model quantity of the Pdm series unit	Default:One module 2:Two modules 3:Three modules 4:Four modules
7	Refrigerant	Na: R410A
8	Series number	B: Product serial number
9	Power supply	M:3808-415V 3Ph~ 50Hz

## 3 FUNCTION

### ※ For Comfortable Air Conditioning

- ◆ Auto Restart
- ◆ Fan Operation Mode
- ◆ LCD Remote Controller (Option)
- ◆ Auto Swing Function
- ◆ Ceiling Soiling Prevention
- ◆ Program Dry
- ◆ High Fan Speed Mode
- ◆ High Ceiling Application
- ◆ Two Select Thermal Sensor
- ◆ Hot Start
- ◆ Timer Selector

### ※ For Easy Construction and Maintenance

- ◆ Fresh Air Intake Directly from The Unit
- ◆ Drain Pump
- ◆ Long Life Filter
- ◆ Ultra-Long life Filter (Option)
- ◆ Mold Resistant Treatment for Filter
- ◆ Filter Sign
- ◆ Mold Resistant Drain Pan
- ◆ Emergency Operation
- ◆ Self Diagnoses Function

### ※ For Flexible Control

- ◆ Set Back Time Clock
- ◆ Double Remote Control
- ◆ Group Control By 1 Remote Controller
- ◆ Control By External Command
- ◆ Remote/Centralized Control

## 4 PRODUCT DATA

### 4.1 Product Data of Outdoor Unit

Model(Combined unit)			—	—	—
Model			GMV-Pdm224W/NaB-M	GMV-Pdm280W/NaB-M	GMV-Pdm335W/NaB-M
Capacity	Cooling	kW	22.4	28	33.5
		kBtu/h	76.43	95.536	114.302
	Heating	kW	25	31.5	37.5
		kBtu/h	85.3	107.478	127.95
Sound Pressure Level		dB(A)	58	58	60
Power Supply		V/Hz/Ph	380-415V~50Hz-3Ph		
Power input	Cooling	kW	5.52	7.52	9.23
	Heating	kW	5.82	7.7	9.38
Current	Cooling	A	9.87	13.44	16.50
	Heating	A	10.4	13.76	16.77
Circuit breaker		A	32	32	40
Recommended Power Lines		mm <sup>2</sup> ×N	6×5	6×5	10×5
Moisture protection			IP24	IP24	IP24
Climate Type			T1	T1	T1
Connecting pipe	Gas Pipe	mm	Φ22.2	Φ22.2	Φ28.6
		Inch	7/8	7/8	9/8
	Liquid Pipe	mm	Φ9.52	Φ9.52	Φ12.7
		Inch	3/8	3/8	1/2
	Oil Pipe	mm	—	—	—
		Inch	—	—	—
Connection Method			Brazing Connection	Brazing Connection	Brazing Connection
Dimensions of Unit	Width	mm	930	930	1340
	Depth	mm	770	770	770
	Height	mm	1670	1670	1670
Dimensions of Package	Width	mm	1010	1010	1420
	Depth	mm	850	850	850
	Height	mm	1850	1850	1850
Net Weight		kg	255	255	350
Gross Weight		kg	275	275	380
Loading Quantity ( 20' Container )		unit	12	12	7
Loading Quantity ( 40' Container )		unit	24	24	16
Loading Quantity ( 40' High Cube Container )		unit	24	24	16

#### Notes:

- ① . The sound level is tested under circumstance of semi-anechoic chamber; the value of noise could be a little higher in actual operation.
- ② . The data will change with the change of products. Refer to those parameters listed on nameplate.
- ③ . The charge amount of refrigerant in the list is the datum when there is not drop height vertically between indoor unit and outdoor unit, without consideration of connection pipe. So calculate the additional charge amount according to actual condition during installation.
- ④ . Section area of lead wire is only applicable for 15-m distance.If above, increase the section area to avoid overload of current which would cause burnout of lead wire.
- ⑤ . The outdoor fan of this unit is without static pressure.If static pressure is required, please specially notice it on purchase order.
- ⑥ . Running condition of cooling: outdoor temperature -5°C~48°C; Running condition of heating: outdoor temperature -20°C~27°C.

Model(Combined unit)		—	—	GMV-Pdm504W2/NaB-M	
Model		GMV-Pdm400W/NaB-M	GMV-Pdm450W/NaB-M	GMV-Pdm224W/NaB-M +GMV-Pdm280W/NaB-M	
Capacity	Cooling	kW	40	45	50.4
		kBtu/h	136.48	153.54	171.964
	Heating	kW	45	50	56.5
		kBtu/h	153.54	170.6	192.778
Sound Pressure Level		dB(A)	61	61	62
Power Supply		V/Hz/Ph	380-415V~50Hz-3Ph		
Power input	Cooling	kW	12.45	14.32	5.52+7.52
	Heating	kW	11.2	13.9	5.82+7.70
Current	Cooling	A	22.25	25.6	9.87+13.44
	Heating	A	20.02	24.85	10.4+13.76
Circuit breaker		A	40	40	32+32
Recommended Power Lines		mm <sup>2</sup> ×N	10×5	10×5	6×5+6×5
Moisture protection			IP24	IP24	IP24
Climate Type			T1	T1	T1
Connecting pipe	Gas Pipe	mm	Φ28.6	Φ28.6	Φ28.6
		Inch	9/8	9/8	9/8
	Liquid Pipe	mm	Φ12.7	Φ12.7	Φ15.9
		Inch	1/2	1/2	5/8
	Oil Pipe	mm	—	—	Φ12.7
		Inch	—	—	1/2
Connection Method			Brazing Connection	Brazing Connection	Brazing Connection
Dimensions of Unit	Width	mm	1340	1340	930+930
	Depth	mm	770	770	770+770
	Height	mm	1670	1670	1670+1670
Dimensions of Package	Width	mm	1420	1420	1010+1010
	Depth	mm	850	850	850+850
	Height	mm	1850	1850	1850+1850
Net Weight		kg	350	370	255+255
Gross Weight		kg	380	400	275+275
Loading Quantity ( 20' Container )		unit	7	7	—
Loading Quantity ( 40' Container )		unit	16	16	—
Loading Quantity ( 40' High Cube Container )		unit	24	24	—

**Notes:**

- ① . The sound level is tested under circumstance of semi-anechoic chamber; the value of noise could be a little higher in actual operation.
- ② . The data will change with the change of products. Refer to those parameters listed on nameplate.
- ③ . The charge amount of refrigerant in the list is the datum when there is not drop height vertically between indoor unit and outdoor unit, without consideration of connection pipe. So calculate the additional charge amount according to actual condition during installation.
- ④ . Section area of lead wire is only applicable for 15-m distance.If above, increase the section area to avoid overload of current which would cause burnout of lead wire.
- ⑤ . The outdoor fan of this unit is without static pressure.If static pressure is required, please specially notice it on purchase order.
- ⑥ . Running condition of cooling: outdoor temperature -5°C~48°C; Running condition of heating: outdoor temperature -20°C~27°C.

Model(Combined unit)		GMV-Pdm560W2/NaB-M	GMV-Pdm615W2/NaB-M	GMV-Pdm670W2/NaB-M	
Model		GMV-Pdm280W/NaB-M +GMV-Pdm280W/NaB-M	GMV-Pdm280W/NaB-M +GMV-Pdm335W/NaB-M	GMV-Pdm280W/NaB-M +GMV-Pdm400W/NaB-M	
Capacity	Cooling	kW	56.0	61.5	68.0
		kBtu/h	191.072	209.838	232.016
	Heating	kW	63.0	69.0	76.5
		kBtu/h	214.956	235.428	261.018
Sound Pressure Level		dB(A)	62	62	62
Power Supply		V/Hz/Ph	380-415V~50Hz-3Ph		
Power input	Cooling	kW	7.52+7.52	7.52+9.23	7.52+12.45
	Heating	kW	7.70+7.70	7.70+9.38	7.70+11.2
Current	Cooling	A	13.44+13.44	13.44+16.50	13.44+22.25
	Heating	A	13.76+13.76	13.76+16.77	13.76+20.02
Circuit breaker		A	32+32	32+40	32+40
Recommended Power Lines		mm <sup>2</sup> ×N	6×5+6×5	6×5+10×5	6×5+10×5
Moisture protection			IP24	IP24	IP24
Climate Type			T1	T1	T1
Connecting pipe	Gas Pipe	mm	Φ28.6	Φ28.6	Φ28.6
		Inch	9/8	9/8	9/8
	Liquid Pipe	mm	Φ15.9	Φ15.9	Φ15.9
		Inch	5/8	5/8	5/8
	Oil Pipe	mm	Φ12.7	Φ12.7	Φ12.7
		Inch	1/2	1/2	1/2
Connection Method			Brazing Connection	Brazing Connection	Brazing Connection
Dimensions of Unit	Width	mm	930+930	930+1340	930+1340
	Depth	mm	770+770	770+770	770+770
	Height	mm	1670+1670	1670+1670	1670+1670
Dimensions of Package	Width	mm	1010+1010	1010+1420	1010+1420
	Depth	mm	850+850	850+850	850+850
	Height	mm	1850+1850	1850+1850	1850+1850
Net Weight		kg	255+255	255+350	255+350
Gross Weight		kg	275+275	275+380	275+380
Loading Quantity ( 20' Container )		unit	—	—	—
Loading Quantity ( 40' Container )		unit	—	—	—
Loading Quantity ( 40' High Cube Container )		unit	—	—	—

**Notes:**

- ① . The sound level is tested under circumstance of semi-anechoic chamber; the value of noise could be a little higher in actual operation.
- ② . The data will change with the change of products. Refer to those parameters listed on nameplate.
- ③ . The charge amount of refrigerant in the list is the datum when there is not drop height vertically between indoor unit and outdoor unit, without consideration of connection pipe. So calculate the additional charge amount according to actual condition during installation.
- ④ . Section area of lead wire is only applicable for 15-m distance.If above, increase the section area to avoid overload of current which would cause burnout of lead wire.
- ⑤ . The outdoor fan of this unit is without static pressure.If static pressure is required, please specially notice it on purchase order.
- ⑥ . Running condition of cooling: outdoor temperature -5°C~48°C; Running condition of heating: outdoor temperature -20°C~27°C.

Model(Combined unit)		GMV-Pdm730W2/NaB-M	GMV-Pdm785W2/NaB-M	GMV-Pdm850W2/NaB-M	
Model		GMV-Pdm280W/NaB-M +GMV-Pdm450W/NaB-M	GMV-Pdm335W/NaB-M +GMV-Pdm450W/NaB-M	GMV-Pdm400W/NaB-M +GMV-Pdm450W/NaB-M	
Capacity	Cooling	kW	73.0	80.0	85.0
		kBtu/h	249.076	272.960	290.020
	Heating	kW	81.5	90.0	95.0
		kBtu/h	278.078	307.080	324.140
Sound Pressure Level		dB(A)	63	63	63
Power Supply		V/Hz/Ph	380-415V~50Hz-3Ph		
Power input	Cooling	kW	7.52+14.32	9.23+14.32	12.45+14.32
	Heating	kW	7.70+13.90	9.38+13.90	11.20+13.90
Current	Cooling	A	13.44+25.6	16.50+25.60	22.25+25.60
	Heating	A	13.76+24.85	16.77+24.85	20.02+24.85
Circuit breaker		A	32+40	40+40	40+40
Recommended Power Lines		mm <sup>2</sup> ×N	6×5+10×5	10×5+10×5	10×5+10×5
Moisture protection			IP24	IP24	IP24
Climate Type			T1	T1	T1
Connecting pipe	Gas Pipe	mm	Φ34.9	Φ34.9	Φ34.9
		Inch	1 1/8	1 1/8	1 1/8
	Liquid Pipe	mm	Φ19.05	Φ19.05	Φ19.05
		Inch	3/4	3/4	3/4
	Oil Pipe	mm	Φ12.7	Φ12.7	Φ12.7
		Inch	1/2	1/2	1/2
Connection Method			Brazing Connection	Brazing Connection	Brazing Connection
Dimensions of Unit	Width	mm	930+1340	1340+1340	1340+1340
	Depth	mm	770+770	770+770	770+770
	Height	mm	1670+1670	1670+1670	1670+1670
Dimensions of Package	Width	mm	1010+1420	1420+1420	1420+1420
	Depth	mm	850+850	850+850	850+850
	Height	mm	1850+1850	1850+1850	1850+1850
Net Weight		kg	255+370	350+370	350+370
Gross Weight		kg	275+400	380+400	380+400
Loading Quantity ( 20' Container )		unit	—	—	—
Loading Quantity ( 40' Container )		unit	—	—	—
Loading Quantity ( 40' High Cube Container )		unit	—	—	—

**Notes:**

- ① . The sound level is tested under circumstance of semi-anechoic chamber; the value of noise could be a little higher in actual operation.
- ② . The data will change with the change of products. Refer to those parameters listed on nameplate.
- ③ . The charge amount of refrigerant in the list is the datum when there is not drop height vertically between indoor unit and outdoor unit, without consideration of connection pipe. So calculate the additional charge amount according to actual condition during installation.
- ④ . Section area of lead wire is only applicable for 15-m distance.If above, increase the section area to avoid overload of current which would cause burnout of lead wire.
- ⑤ . The outdoor fan of this unit is without static pressure.If static pressure is required, please specially notice it on purchase order.
- ⑥ . Running condition of cooling: outdoor temperature -5℃~48℃; Running condition of heating: outdoor temperature -20℃~27℃.

Model(Combined unit)			GMV-Pdm900W2/NaB-M	GMV-Pdm950W3/NaB-M	GMV-Pdm1008W3/NaB-M
Model			GMV-Pdm450W/NaB-M +GMV-Pdm450W/NaB-M	GMV-Pdm280W/NaB-M +GMV-Pdm280W/NaB-M +GMV-Pdm400W/NaB-M	GMV-Pdm280W/NaB-M +GMV-Pdm280W/NaB-M +GMV-Pdm450W/NaB-M
Capacity	Cooling	kW	90.0	96.0	101.0
		kBtu/h	307.080	327.552	344.612
	Heating	kW	100.0	108.0	113.0
		kBtu/h	341.200	368.496	385.526
Sound Pressure Level		dB(A)	63	64	64
Power Supply		V/Hz/Ph	380-415V~50Hz-3Ph		
Power input	Cooling	kW	14.32+14.32	7.52+7.52+12.45	7.52+7.52+14.32
	Heating	kW	13.90+13.90	7.70+7.70+11.2	7.70+7.70+13.90
Current	Cooling	A	25.6+25.6	13.44+13.44+22.25	13.44+13.44+25.6
	Heating	A	24.85+24.85	13.76+13.76+20.02	13.76+13.76+24.85
Circuit breaker		A	40+40	32+32+40	32+32+40
Recommended Power Lines		mm <sup>2</sup> ×N	10×5+10×5	6×5+6×5+10×5	6×5+6×5+10×5
Moisture protection			IP24	IP24	IP24
Climate Type			T1	T1	T1
Connecting pipe	Gas Pipe	mm	Φ34.9	Φ34.9	Φ41.3
		Inch	1 1/8	1 1/8	1 3/8
	Liquid Pipe	mm	Φ19.05	Φ19.05	Φ19.05
		Inch	3/4	3/4	3/4
	Oil Pipe	mm	Φ12.7	Φ12.7	Φ12.7
		Inch	1/2	1/2	1/2
Connection Method			Brazing Connection	Brazing Connection	Brazing Connection
Dimensions of Unit	Width	mm	1340+1340	930+930+1340	930+930+1340
	Depth	mm	770+770	770+770+770	770+770+770
	Height	mm	1670+1670	1670+1670+1670	1670+1670+1670
Dimensions of Package	Width	mm	1420+1420	1010+1010+1420	1010+1010+1420
	Depth	mm	850+850	850+850+850	850+850+850
	Height	mm	1850+1850	1850+1850+1850	1850+1850+1850
Net Weight		kg	370+370	255+255+350	255+255+370
Gross Weight		kg	400+400	275+275+380	275+275+400
Loading Quantity ( 20' Container )		unit	—	—	—
Loading Quantity ( 40' Container )		unit	—	—	—
Loading Quantity ( 40' High Cube Container )		unit	—	—	—

**Notes:**

- ① . The sound level is tested under circumstance of semi-anechoic chamber; the value of noise could be a little higher in actual operation.
- ② . The data will change with the change of products. Refer to those parameters listed on nameplate.
- ③ . The charge amount of refrigerant in the list is the datum when there is not drop height vertically between indoor unit and outdoor unit, without consideration of connection pipe. So calculate the additional charge amount according to actual condition during installation.
- ④ . Section area of lead wire is only applicable for 15-m distance.If above, increase the section area to avoid overload of current which would cause burnout of lead wire.
- ⑤ . The outdoor fan of this unit is without static pressure.If static pressure is required, please specially notice it on purchase order.
- ⑥ . Running condition of cooling: outdoor temperature -5°C~48°C; Running condition of heating: outdoor temperature -20°C~27°C.

Model(Combined unit)		GMV-Pdm1065W3/NaB-M	GMV-Pdm1130W3/NaB-M	GMV-Pdm1180W3/NaB-M	
Model		GMV-Pdm280W/NaB-M +GMV-Pdm335W/NaB-M +GMV-Pdm450W/NaB-M	GMV-Pdm280W/NaB-M +GMV-Pdm400W/NaB-M +GMV-Pdm450W/NaB-M	GMV-Pdm280W/NaB-M +GMV-Pdm450W/NaB-M +GMV-Pdm450W/NaB-M	
Capacity	Cooling	kW	108.0	113.0	118.0
		kBtu/h	368.469	385.556	402.616
	Heating	kW	121.5	126.5	131.5
		kBtu/h	414.558	431.618	448.678
Sound Pressure Level		dB(A)	64	64	64
Power Supply		V/Hz/Ph	380-415V~50Hz-3Ph		
Power input	Cooling	kW	7.52+9.23+14.32	7.52+12.45+14.32	7.52+14.32+14.32
	Heating	kW	7.70+9.38+13.9	7.70+11.2+13.9	7.70+13.90+13.90
Current	Cooling	A	13.44+16.50+25.6	13.44+22.25+25.6	13.44+25.6+25.6
	Heating	A	13.76+16.77+24.85	13.76+20.02+24.85	13.76+24.85+24.85
Circuit breaker		A	32+40+40	32+40+40	32+40+40
Recommended Power Lines		mm <sup>2</sup> ×N	6×5+10×5+10×5	6×5+10×5+10×5	6×5+10×5+10×5
Moisture protection			IP24	IP24	IP24
Climate Type			T1	T1	T1
Connecting pipe	Gas Pipe	mm	Φ41.3	Φ41.3	Φ41.3
		Inch	13/8	13/8	13/8
	Liquid Pipe	mm	Φ19.05	Φ19.05	Φ19.05
		Inch	3/4	3/4	3/4
	Oil Pipe	mm	Φ12.7	Φ12.7	Φ12.7
		Inch	1/2	1/2	1/2
	Connection Method			Brazing Connection	Brazing Connection
Dimensions of Unit	Width	mm	930+1340+1340	930+1340+1340	930+1340+1340
	Depth	mm	770+770+770	770+770+770	770+770+770
	Height	mm	1670+1670+1670	1670+1670+1670	1670+1670+1670
Dimensions of Package	Width	mm	1010+1420+1420	1010+1420+1420	1010+1420+1420
	Depth	mm	850+850+850	850+850+850	850+850+850
	Height	mm	1850+1850+1850	1850+1850+1850	1850+1850+1850
Net Weight		kg	255+350+370	255+350+370	255+370+370
Gross Weight		kg	275+380+400	275+380+400	275+400+400
Loading Quantity ( 20' Container )		unit	—	—	—
Loading Quantity ( 40' Container )		unit	—	—	—
Loading Quantity ( 40' High Cube Container )		unit	—	—	—

**Notes:**

- ① . The sound level is tested under circumstance of semi-anechoic chamber; the value of noise could be a little higher in actual operation.
- ② . The data will change with the change of products. Refer to those parameters listed on nameplate.
- ③ . The charge amount of refrigerant in the list is the datum when there is not drop height vertically between indoor unit and outdoor unit, without consideration of connection pipe. So calculate the additional charge amount according to actual condition during installation.
- ④ . Section area of lead wire is only applicable for 15-m distance.If above, increase the section area to avoid overload of current which would cause burnout of lead wire.
- ⑤ . The outdoor fan of this unit is without static pressure.If static pressure is required, please specially notice it on purchase order.
- ⑥ . Running condition of cooling: outdoor temperature -5°C~48°C; Running condition of heating: outdoor temperature -20°C~27°C.



Model(Combined unit)		GMV-Pdm1235W3/NaB-M	GMV-Pdm1300W3/NaB-M	GMV-Pdm1350W3/NaB-M	
Model		GMV-Pdm335W/NaB-M +GMV-Pdm450W/NaB-M +GMV-Pdm450W/NaB-M	GMV-Pdm400W/NaB-M +GMV-Pdm450W/NaB-M +GMV-Pdm450W/NaB-M	GMV-Pdm450W/NaB-M +GMV-Pdm450W/NaB-M +GMV-Pdm450W/NaB-M	
Capacity	Cooling	kW	125.0	130.0	135.0
		kBtu/h	426.500	443.560	460.620
	Heating	kW	14.0	145.0	150.0
		kBtu/h	477.680	494.740	511.800
Sound Pressure Level		dB(A)	65	65	65
Power Supply		V/Hz/Ph	380-415V~50Hz-3Ph		
Power input	Cooling	kW	9.23+14.32+14.32	12.45+14.32+14.32	14.32+14.32+14.32
	Heating	kW	9.38+13.9+13.9	11.2+13.9+13.9	13.90+13.90+13.90
Current	Cooling	A	16.5+25.6+25.6	22.25+25.6+25.6	25.6+25.6+25.6
	Heating	A	16.77+24.85+24.85	20.02+24.85+24.85	24.85+24.85+24.85
Circuit breaker		A	40+40+40	40+40+40	40+40+40
Recommended Power Lines		mm <sup>2</sup> ×N	10×5+10×5+10×5	10×5+10×5+10×5	10×5+10×5+10×5
Moisture protection			IP24	IP24	IP24
Climate Type			T1	T1	T1
Connecting pipe	Gas Pipe	mm	Φ41.3	Φ41.3	Φ41.3
		Inch	13/8	13/8	13/8
	Liquid Pipe	mm	Φ19.05	Φ19.05	Φ19.05
		Inch	3/4	3/4	3/4
	Oil Pipe	mm	Φ12.7	Φ12.7	Φ12.7
		Inch	1/2	1/2	1/2
Connection Method			Brazing Connection	Brazing Connection	Brazing Connection
Dimensions of Unit	Width	mm	1340+1340+1340	1340+1340+1340	1340+1340+1340
	Depth	mm	770+770+770	770+770+770	770+770+770
	Height	mm	1670+1670+1670	1670+1670+1670	1670+1670+1670
Dimensions of Package	Width	mm	1420+1420+1420	1420+1420+1420	1420+1420+1420
	Depth	mm	850+850+850	850+850+850	850+850+850
	Height	mm	1850+1850+1850	1850+1850+1850	1850+1850+1850
Net Weight		kg	350+370+370	350+370+370	370+370+370
Gross Weight		kg	380+400+400	380+400+400	400+400+400
Loading Quantity ( 20' Container )		unit	—	—	—
Loading Quantity ( 40' Container )		unit	—	—	—
Loading Quantity ( 40' High Cube Container )		unit	—	—	—

**Notes:**

- ① . The sound level is tested under circumstance of semi-anechoic chamber; the value of noise could be a little higher in actual operation.
- ② . The data will change with the change of products. Refer to those parameters listed on nameplate.
- ③ . The charge amount of refrigerant in the list is the datum when there is not drop height vertically between indoor unit and outdoor unit, without consideration of connection pipe. So calculate the additional charge amount according to actual condition during installation.
- ④ . Section area of lead wire is only applicable for 15-m distance.If above, increase the section area to avoid overload of current which would cause burnout of lead wire.
- ⑤ . The outdoor fan of this unit is without static pressure.If static pressure is required, please specially notice it on purchase order.
- ⑥ . Running condition of cooling: outdoor temperature -5°C~48°C; Running condition of heating: outdoor temperature -20°C~27°C.

Model(Combined unit)			GMV-Pdm1405W4/NaB-M	GMV-Pdm1456W4/NaB-M	GMV-Pdm1512W4/NaB-M
Model			GMV-Pdm280W/NaB-M +GMV-Pdm280W/NaB-M +GMV-Pdm400W/NaB-M +GMV-Pdm450W/NaB-M	GMV-Pdm280W/NaB-M +GMV-Pdm280W/NaB-M +GMV-Pdm450W/NaB-M +GMV-Pdm450W/NaB-M	GMV-Pdm280W/NaB-M +GMV-Pdm335W/NaB-M +GMV-Pdm450W/NaB-M +GMV-Pdm450W/NaB-M
Capacity	Cooling	kW	141.0	146.0	153.0
		kBtu/h	481.092	498.152	522.036
	Heating	kW	158.0	163.0	171.0
		kBtu/h	539.096	556.156	585.158
Sound Pressure Level		dB(A)	65	65	65
Power Supply		V/Hz/Ph	380-415V~50Hz-3Ph		
Power input	Cooling	kW	7.52+7.52+12.45+14.32	7.52+7.52+14.32+14.32	7.52+9.23+14.32+14.32
	Heating	kW	7.707.70+11.2+13.9	7.70+7.70+13.90+13.90	7.70+9.38+13.90+13.90
Current	Cooling	A	13.44+13.44+22.25+25.6	13.44+13.44+25.6+25.6	13.44+16.50+25.6+25.6
	Heating	A	13.76+13.76+20.02+24.85	13.76+13.76+24.85+24.85	13.76+16.77+24.85+24.85
Circuit breaker		A	31+32+40+40	32+32+40+40	32+40+40+40
Recommended Power Lines		mm <sup>2</sup> ×N	6×5+6×5+10×5+10×5	6×5+6×5+10×5+10×5	6×5+10×5+10×5+10×5
Moisture protection			IP24	IP24	IP24
Climate Type			T1	T1	T1
Connecting pipe	Gas Pipe	mm	Φ44.5	Φ44.5	Φ41.3
		Inch	7/4	7/4	13/8
	Liquid Pipe	mm	Φ22.2	Φ22.2	Φ19.05
		Inch	7/8	7/8	3/4
	Oil Pipe	mm	Φ12.7	Φ12.7	Φ12.7
		Inch	1/2	1/2	1/2
Connection Method			Brazing Connection	Brazing Connection	Brazing Connection
Dimensions of Unit	Width	mm	930+930+1340+1340	930+930+1340+1340	930+1340+1340+1340
	Depth	mm	770+770+770+770	770+770+770+770	770+770+770+770
	Height	mm	1670+1670+1670+1670	1670+1670+1670+1670	1670+1670+1670+1670
Dimensions of Package	Width	mm	1010+1010+1420+1420	1010+1010+1420+1420	1010+1420+1420+1420
	Depth	mm	850+850+850+850	850+850+850+850	850+850+850+850
	Height	mm	1850+1850+1850+1850	1850+1850+1850+1850	1850+1850+1850+1850
Net Weight		kg	255+255+350+370	255+255+370+370	255+350+370+370
Gross Weight		kg	275+275+380+400	275+275+400+400	275+380+400+400
Loading Quantity ( 20' Container )		unit	—	—	—
Loading Quantity ( 40' Container )		unit	—	—	—
Loading Quantity ( 40' High Cube Container )		unit	—	—	—

**Notes:**

- ① . The sound level is tested under circumstance of semi-anechoic chamber; the value of noise could be a little higher in actual operation.
- ② . The data will change with the change of products. Refer to those parameters listed on nameplate.
- ③ . The charge amount of refrigerant in the list is the datum when there is not drop height vertically between indoor unit and outdoor unit, without consideration of connection pipe. So calculate the additional charge amount according to actual condition during installation.
- ④ . Section area of lead wire is only applicable for 15-m distance.If above, increase the section area to avoid overload of current which would cause burnout of lead wire.
- ⑤ . The outdoor fan of this unit is without static pressure.If static pressure is required, please specially notice it on purchase order.
- ⑥ . Running condition of cooling: outdoor temperature -5°C~48°C; Running condition of heating: outdoor temperature -20°C~27°C.

Model(Combined unit)			GMV-Pdm1570W4/NaB-M	GMV-Pdm1650W4/NaB-M	GMV-Pdm1700W4/NaB-M
Model			GMV-Pdm280W/NaB-M +GMV-Pdm400W/NaB-M +GMV-Pdm450W/NaB-M +GMV-Pdm450W/NaB-M	GMV-Pdm280W/NaB-M +GMV-Pdm450W/NaB-M +GMV-Pdm450W/NaB-M +GMV-Pdm450W/NaB-M	GMV-Pdm335W/NaB-M +GMV-Pdm450W/NaB-M +GMV-Pdm450W/NaB-M +GMV-Pdm450W/NaB-M
Capacity	Cooling	kW	155.0	163.0	170.0
		kBtu/h	528.860	556.156	580.040
	Heating	kW	176.5	181.5	190.0
		kBtu/h	602.218	619.278	648.280
Sound Pressure Level		dB(A)	65	65	66
Power Supply		V/Hz/Ph	380-415V~50Hz-3Ph		
Power input	Cooling	kW	7.52+12.45+14.32+14.32	7.52+14.32+14.32+14.32	9.23+14.32+14.32+14.32
	Heating	kW	7.70+11.2+13.9+13.9	7.70+13.90+13.90+13.90	9.38+13.9+13.9+13.9
Current	Cooling	A	13.44+22.25+25.6+25.6	13.44+25.6+25.6+25.6	16.5+25.6+25.6+25.6
	Heating	A	13.76+20.02+24.85+24.85	13.76+24.85+24.85+24.85	16.77+24.58+24.85+24.85
Circuit breaker		A	32+40+40+40	32+40+40+40	40+40+40+40
Recommended Power Lines		mm <sup>2</sup> ×N	6×5+10×5+10×5+10×5	6×5+10×5+10×5+10×5	10×5+10×5+10×5+10×5
Moisture protection			IP24	IP24	IP24
Climate Type			T1	T1	T1
Connecting pipe	Gas Pipe	mm	Φ44.5	Φ54.1	Φ54.1
		Inch	7/4	17/8	17/8
	Liquid Pipe	mm	Φ22.2	Φ25.4	Φ25.4
		Inch	7/8	1	1
	Oil Pipe	mm	Φ12.7	Φ12.7	Φ12.7
		Inch	1/2	1/2	1/2
Connection Method			Brazing Connection	Brazing Connection	Brazing Connection
Dimensions of Unit	Width	mm	930+1340+1340+1340	930+1340+1340+1340	1340+1340+1340+1340
	Depth	mm	770+770+770+770	770+770+770+770	770+770+770+770
	Height	mm	1670+1670+1670+1670	1670+1670+1670+1670	1670+1670+1670+1670
Dimensions of Package	Width	mm	1010+1420+1420+1420	1010+1420+1420+1420	1420+1420+1420+1420
	Depth	mm	850+850+850+850	850+850+850+850	850+850+850+850
	Height	mm	1850+1850+1850+1850	1850+1850+1850+1850	1850+1850+1850+1850
Net Weight		kg	255+350+370+370	255+370+370+370	350+370+370+370
Gross Weight		kg	275+380+400+400	275+400+400+400	380+400+400+400
Loading Quantity ( 20' Container )		unit	—	—	—
Loading Quantity ( 40' Container )		unit	—	—	—
Loading Quantity ( 40' High Cube Container )		unit	—	—	—

**Notes:**

- ①. The sound level is tested under circumstance of semi-anechoic chamber; the value of noise could be a little higher in actual operation.
- ②. The data will change with the change of products. Refer to those parameters listed on nameplate.
- ③. The charge amount of refrigerant in the list is the datum when there is not drop height vertically between indoor unit and outdoor unit, without consideration of connection pipe. So calculate the additional charge amount according to actual condition during installation.
- ④. Section area of lead wire is only applicable for 15-m distance.If above, increase the section area to avoid overload of current which would cause burnout of lead wire.
- ⑤. The outdoor fan of this unit is without static pressure.If static pressure is required, please specially notice it on purchase order.
- ⑥. Running condition of cooling: outdoor temperature -5°C~48°C; Running condition of heating: outdoor temperature -20°C~27°C.

Model(Combined unit)			GMV-Pdm1750W4/NaB-M	GMV-Pdm1800W4/NaB-M
Model			GMV-Pdm400W/NaB-M +GMV-Pdm450W/NaB-M +GMV-Pdm450W/NaB-M +GMV-Pdm450W/NaB-M	GMV-Pdm450W/NaB-M +GMV-Pdm450W/NaB-M +GMV-Pdm450W/NaB-M +GMV-Pdm450W/NaB-M
Capacity	Cooling	kW	175.0	180.0
		kBtu/h	597.100	614.160
	Heating	kW	195.0	200.0
		kBtu/h	665.340	682.400
Sound Pressure Level		dB(A)	66	66
Power Supply		V/Hz/Ph		
Power input	Cooling	kW	12.45+14.32+14.32+14.32	14.32+14.32+14.32+14.32
	Heating	kW	11.2+13.9013.90+13.90	13.9+13.9+13.9+13.9
Current	Cooling	A	22.25+25.6+25.6+25.6	25.6+25.6+25.6+25.6
	Heating	A	20.02+24.85+24.85+24.85	24.85+24.85+24.85+24.85
Circuit breaker		A	40+40+40+40	40+40+40+40
Recommended Power Lines		mm <sup>2</sup> ×N	10×5+10×5+10×5+10×5	10×5+10×5+10×5+10×5
Moisture protection			IP24	IP24
Climate Type			T1	T1
Connecting pipe	Gas Pipe	mm	Φ54.1	Φ54.1
		Inch	17/8	17/8
	Liquid Pipe	mm	Φ25.4	Φ25.4
		Inch	1	1
	Oil Pipe	mm	Φ12.7	Φ12.7
		Inch	1/2	1/2
Connection Method			Brazing Connection	Brazing Connection
Dimensions of Unit	Width	mm	1340+1340+1340+1340	1340+1340+1340+1340
	Depth	mm	770+770+770+770	770+770+770+770
	Height	mm	1670+1670+1670+1670	1670+1670+1670+1670
Dimensions of Package	Width	mm	1420+1420+1420+1420	1420+1420+1420+1420
	Depth	mm	850+850+850+850	850+850+850+850
	Height	mm	1850+1850+1850+1850	1850+1850+1850+1850
Net Weight		kg	350+370+370+370	370+370+370+370
Gross Weight		kg	380+400+400+400	400+400+400+400
Loading Quantity ( 20' Container )		unit	—	—
Loading Quantity ( 40' Container )		unit	—	—
Loading Quantity ( 40' High Cube Container )		unit	—	—

**Notes:**

- ① . The sound level is tested under circumstance of semi-anechoic chamber; the value of noise could be a little higher in actual operation.
- ② . The data will change with the change of products. Refer to those parameters listed on nameplate.
- ③ . The charge amount of refrigerant in the list is the datum when there is not drop height vertically between indoor unit and outdoor unit, without consideration of connection pipe. So calculate the additional charge amount according to actual condition during installation.
- ④ . Section area of lead wire is only applicable for 15-m distance.If above, increase the section area to avoid overload of current which would cause burnout of lead wire.
- ⑤ . The outdoor fan of this unit is without static pressure.If static pressure is required, please specially notice it on purchase order.
- ⑥ . Running condition of cooling: outdoor temperature -5°C~48°C; Running condition of heating: outdoor temperature -20°C~27°C.

## 5 PIPING DIAGRAM

### 5.1 Piping diagram of GMV-Pdm224W/NaB-M,GMV-Pdm280W/NaB-M

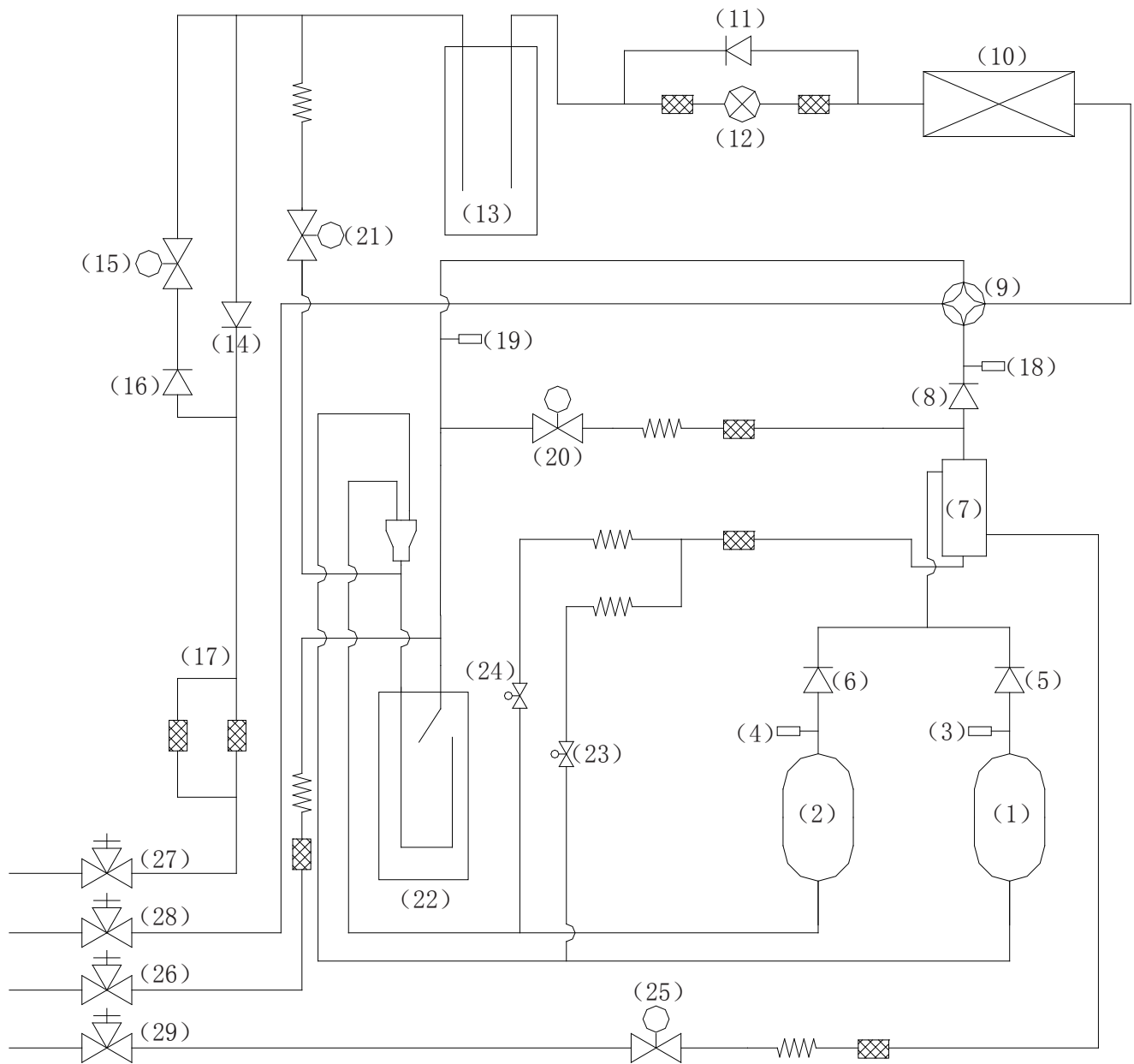

5.2 Piping diagram of GMV-Pdm335W/NaB-M,GMV-Pdm400W/NaB-M,GMV-Pdm450W/NaB-M

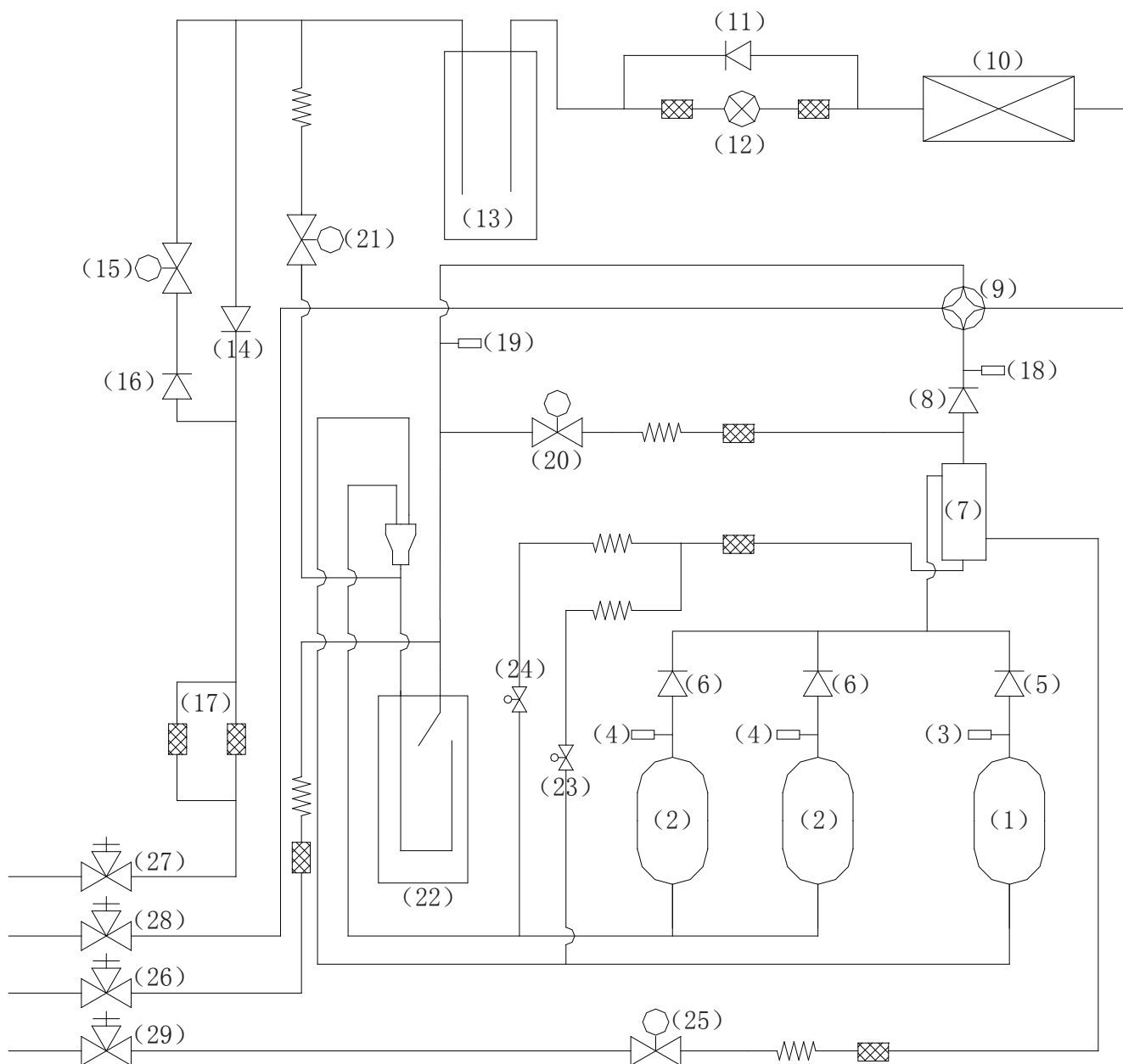

NO.	Name	Major Function
1	Inverter compressor(INV)	According to the actual need, the inverter compressor can adjust its revolution among 30rps~90rps.
2	Standard compressor(STD1/STD2)	When the inverter compressor fails to meet the needs of the system, the fixed-frequency compressor will start together.
3	High pressure switch(for INV)	When the discharge pressure of the inverter compressor exceeds the upper limit of the high pressure switch, a feedback signal will be sent out to stop the unit immediately so as to protect the compressor.
4	High pressure switch(for STD1/ STD2)	When the discharge pressure of the fixed-frequency compressor exceeds the upper limit of the high pressure switch, a feedback signal will be sent out to stop the unit immediately so as to protect the compressor.
5	Check valve(for INV)	It is used to prevent the high-pressure reverse gas going into the inverter compressor at the moment that the compressor stops so as to avoid abnormal startup next time and other problems.

6	Check valve(for STD1/ STD2)	It is used to prevent the high-pressure reverse gas going into the fixed-frequency compressor at the moment the compressor stops so as to avoid abnormal startup next time and other problems.
7	Oil separator	It is used to separate the gas and oil so as to guarantee the reliability of the compressor.
8	Check valve	It is used to prevent the high-pressure reverse gas going into the modules at the moment that the unit stops
9	Four way valve	It is used to change the status of the heat exchanger.
10	Heat exchanger	It is used to exchanger heat outdoor.
11	Check valve	It is used to reduce the pressure loss of the refrigerant flow.
12	Electronic expansion valve	It is used to adjust the degree of superheat and then adjust the refrigerant flow to ensure the reliability and sufficient heat exchange of the system.
13	Receiver	It is used to store unused refrigerant to avoid abnormality.
14	Check valve (for cooling)	It is used under the cooling mode.
15	Solenoid valve (for heating)	It is used under the cooling mode.
16	Check valve	It is used under the cooling mode.
17	Filter-drier	It is used to absorb moisture in the system so as to avoid "ice plug" or "copper plating" on the surface of the compressor
18	High pressure sensor	It is used to detect the real-time high pressure for protecting the compressor and other controls.
19	Low pressure sensor	It is used to detect the real-time low pressure for protecting the compressor and other controls.
20	Solenoid valve (hot gas)	It is used to protect the system running under low pressure or the compressor starting with pressure difference.
21	Solenoid valve (liquid bypass)	It is used to prevent the compressor running at high temperature.
22	Accumulator	It is used to prevent the compressor running at high humidity condition.
23	Solenoid valve(INV)	It is used to return the lubricant to the inverter compressor.
24	Solenoid valve(STD1/ STD2)	It is used to return the lubricant to the fixed-frequency compressor.
25	Solenoid valve(Oil balance)	It is used to balance the lubricant among modules.
26	Servicing valve	It is where the low pressure can be measured and refrigerant can be charged for after-sales maintenance.
27	Liquid pipe	It is the pipe to pass the refrigerant liquid of the system.
28	Gas pipe	It is the pipe to pass the refrigerant gas of the system.
29	Oil balance pipe	It is the pipe to balance the lubricant oil between modules.

# CONTROL



## CONTROL

### 1 CONTROL OF THE UNIT

#### 1.1 Concept of Integral Control of the Unit

##### 1.1.1 Unit Control Schematic Diagram

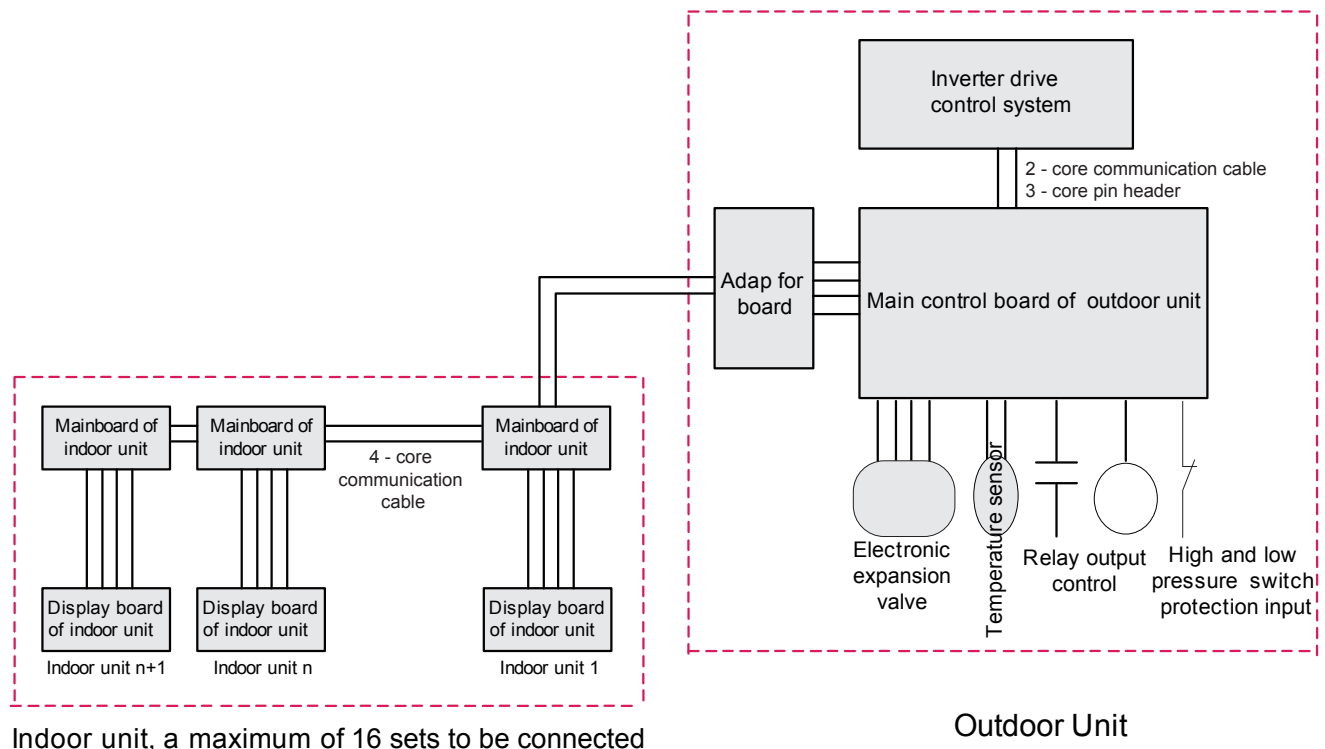

Air conditioning units can be divided into indoor unit and outdoor unit. A maximum of 16 sets of indoor units can be connected to an outdoor unit. 2-core (3-core pin header) communication cable is used for the connection between indoor unit and outdoor unit. Indoor unit is connected to display board via 4-core communication cable. In engineering installation, address dial-up of the display board and the mainboard of indoor unit shall be dialed. The address dial-up of the mainboard of indoor unit must be identical with that of the display board of the same indoor unit. Address dial-up of different indoor unit must vary. Multi VRF indoor unit is applicable to all digital or inverter outdoor units.

Controller of outdoor unit falls into two categories in terms of its function, i.e. main control system and inverter drive control system

##### 1.1.2 DC Inverter Unit

###### 1) Main control system

A. Functions: main control system shall be connected to indoor unit through 2-core (3-core pin header) communication cable in order to receive start or stop commands, mode, setting temperature and ambient temperature from indoor unit, determine operation mode of outdoor unit, and through calculation based on capacity, decide proper running frequency which shall be sent to the drive control system through 2-core (3-core pin header) communication cable. Fan speed shall be regulated according to system pressure. Real-time monitoring of temperature sensors, operation state and protection of unit shall be performed to ensure normal and stable operation of the whole system. Protection codes of outdoor unit shall be displayed on the LED on the main control board when failure occurs. When drive is at fault, E5 shall be displayed on the display board of indoor unit, and specific failure type shall be indicated on the LED on the main control board of outdoor unit.

###### B. Input and output controlled variables

Sensors include ambient temp. sensor, tube-inlet temp. sensor, tube-middle temp. sensor, tube-outlet temp. sensor, compressor exhaust temp. sensor, compressor casing top temp. sensor, high pressure sensor and low pressure sensor.

Switch protection: high pressure protection, over-current protection

Output control objects: fan frequency, compressor heat tape (controlled by drive board), compressor AC

contactor (3-phase, controlled by drive board), gas bypass valve, 4-way valve, solenoid valve A, oil equilibrium valve, liquid bypass valve and capillary solenoid valve.

C. 485 communication interface: indoor unit communication network and adaptor board CN1 shall be connected to the mainboard of indoor unit through 2-core (3-core pin header) communication cable; drive communication network and the mainboards CN11~CN14 of outdoor unit shall be connected to the drive board through 2-core (3-core pin header) communication cable.

## 2) Drive control system

### 3-phase power supply unit

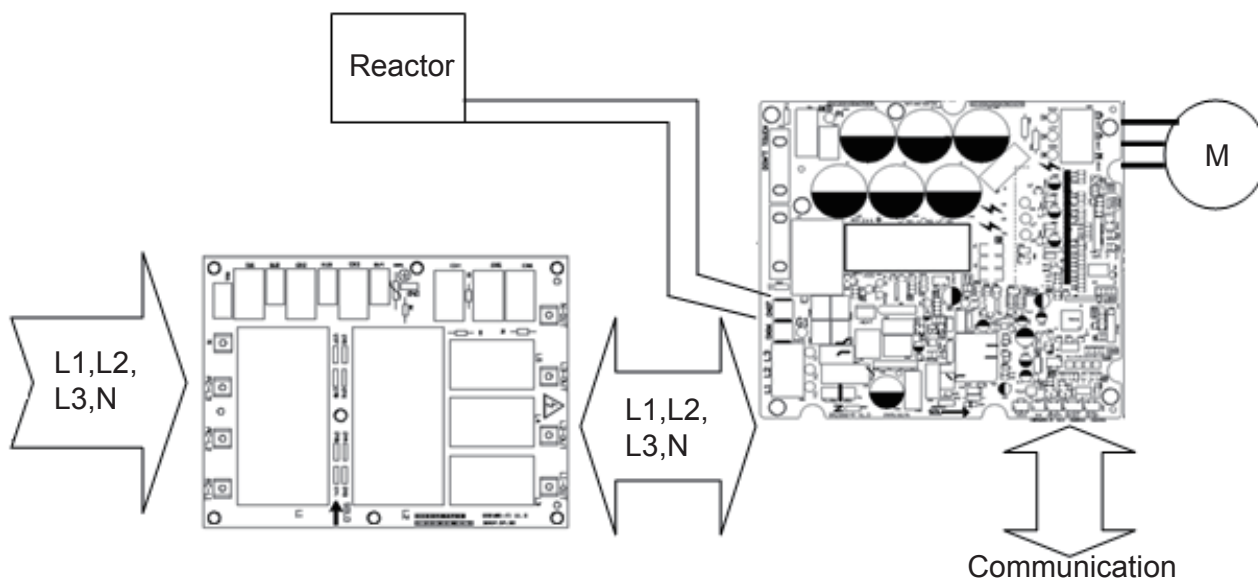

### Functions of various modules:

A Filter plate: one of the two key functions is to filter and eliminate power interferences and ensure anti-interference capability of the unit even in a rugged power supply environment; the other one is to suppress interferences from power supply in order to prevent the operation of the unit from affecting other appliances such as TV. Because inverter unit works in a special way that is relatively sensitive to interferences, filter plate is normally arranged. Because 3-phase power supply is used for the unit, 3-phase filter plate that uses 3-stage filtering mode shall be employed. Input terminals of 3-phase filter plate are respectively AC-L1, AC-L2, AC-L3 and N, and corresponding output terminals are respectively L1-OUT, L2-OUT, L3-OUT and N-OUT.

B Drive board is a key part of control system. Receiving commands from the main control board, the drive board can transform 380V, 50Hz, 3-phase commercial power into AC power with adjustable amplitude and frequency, capable to drive compressor.

### 1.2 Operation Flow Chart of the Unit

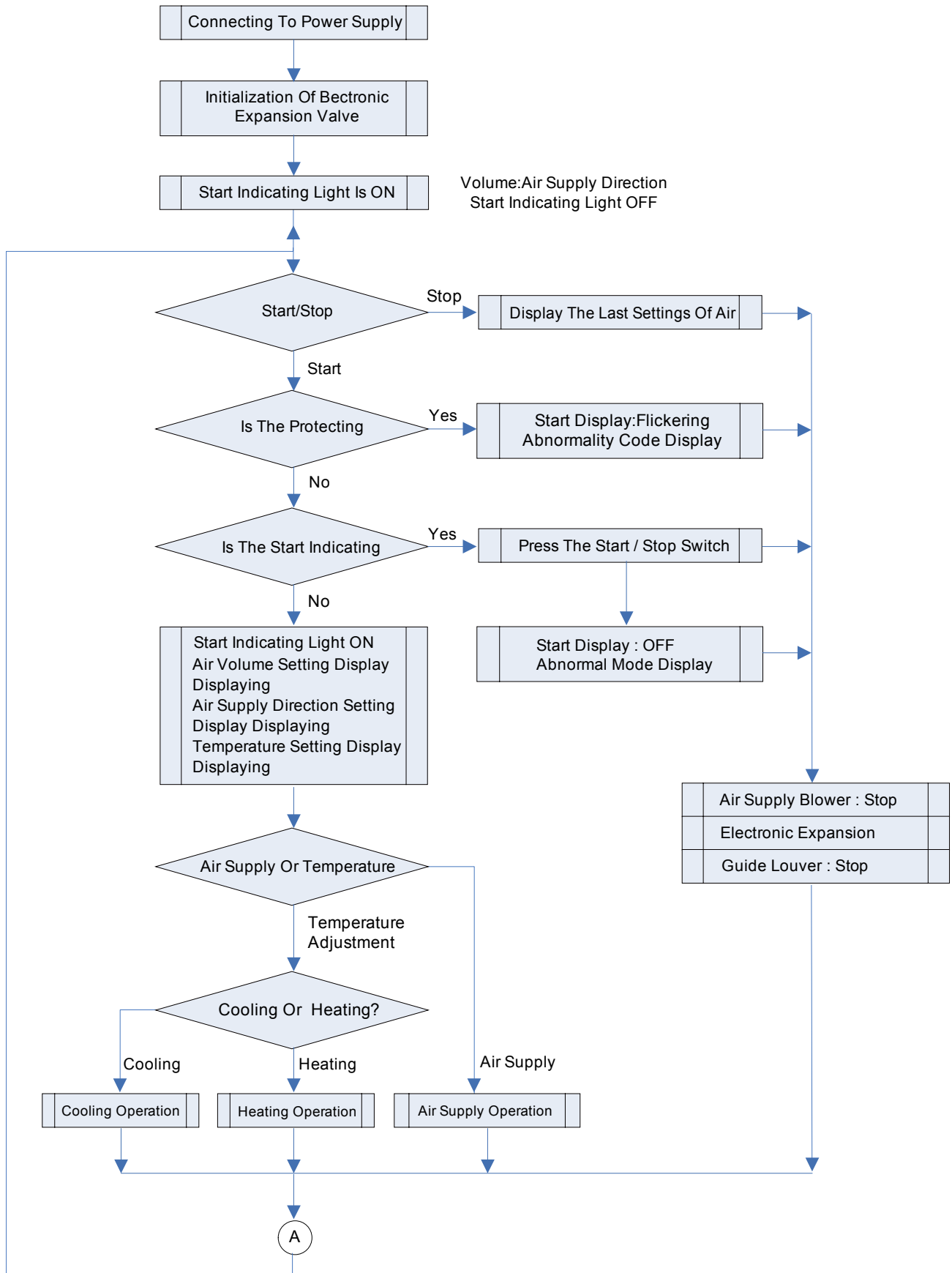

◆ Cooling Operation

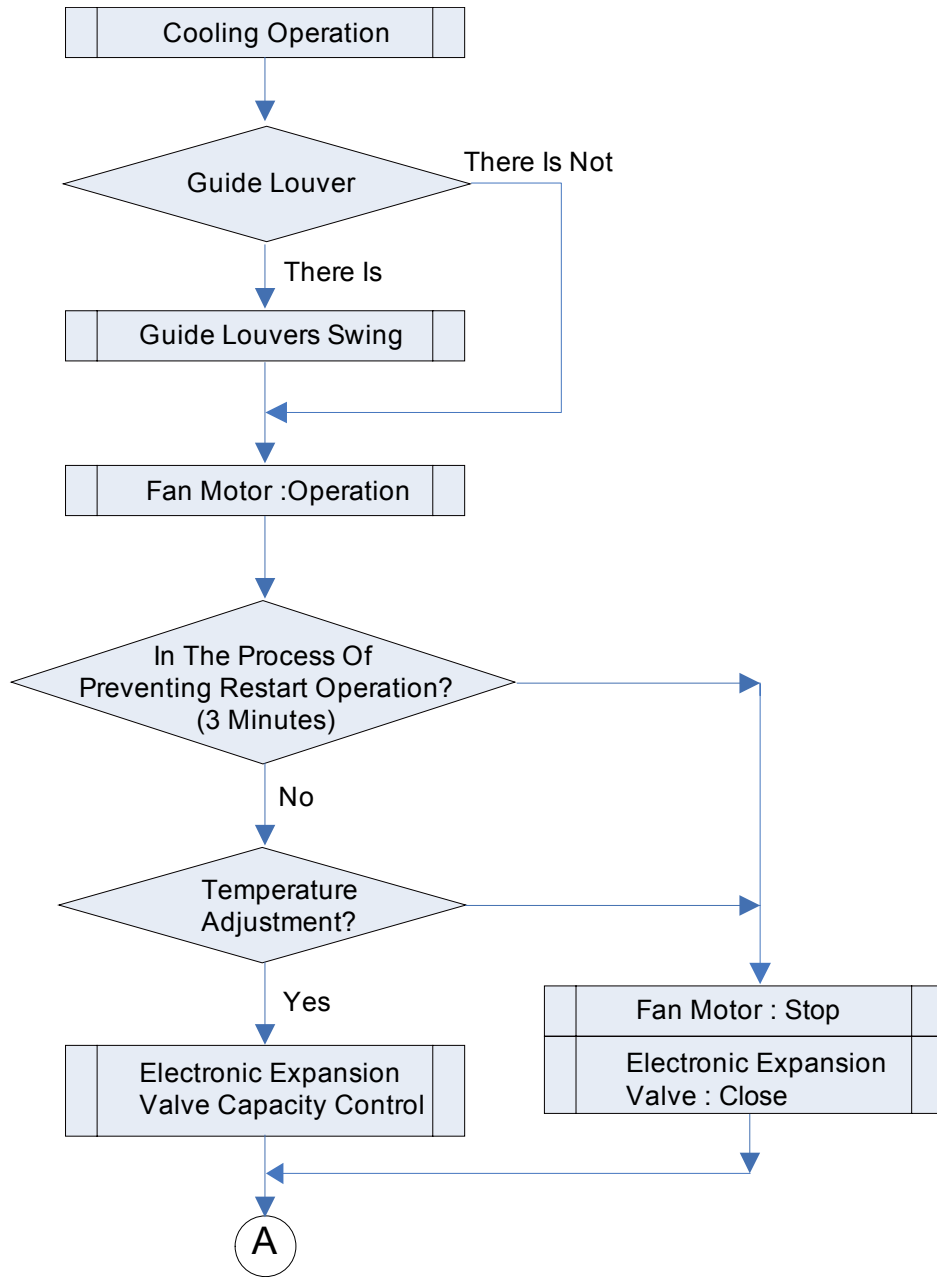

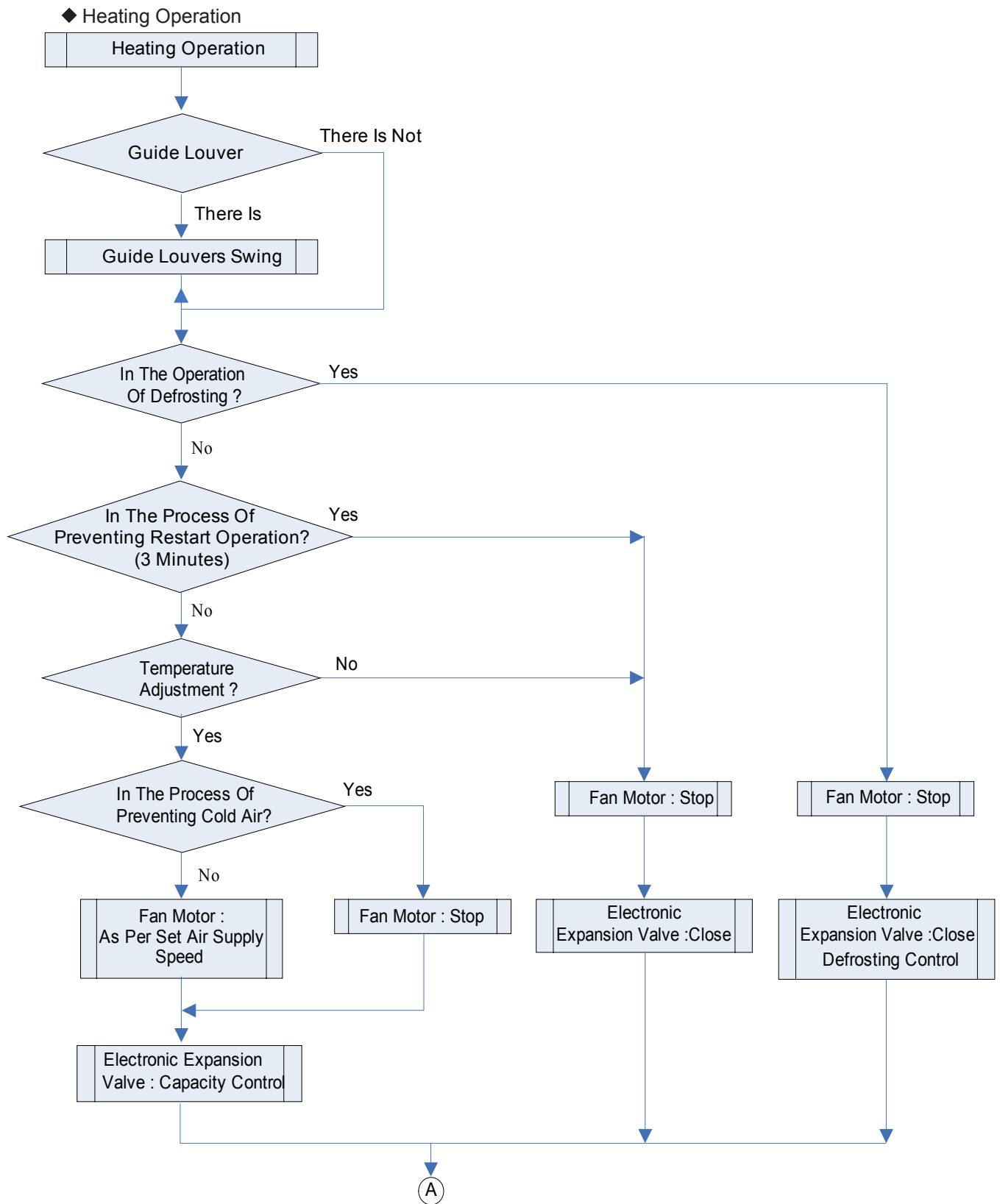

◆ Air supply running

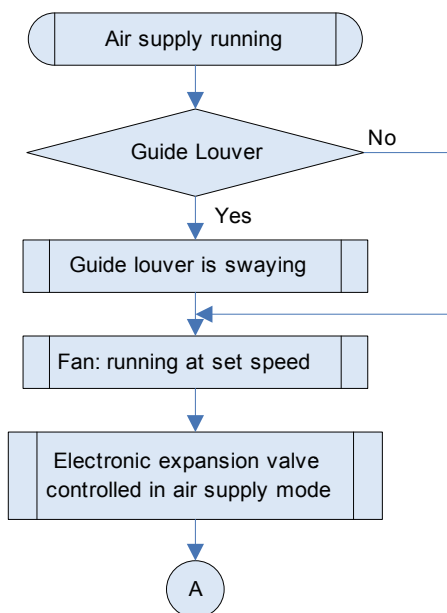

◆ Drying running

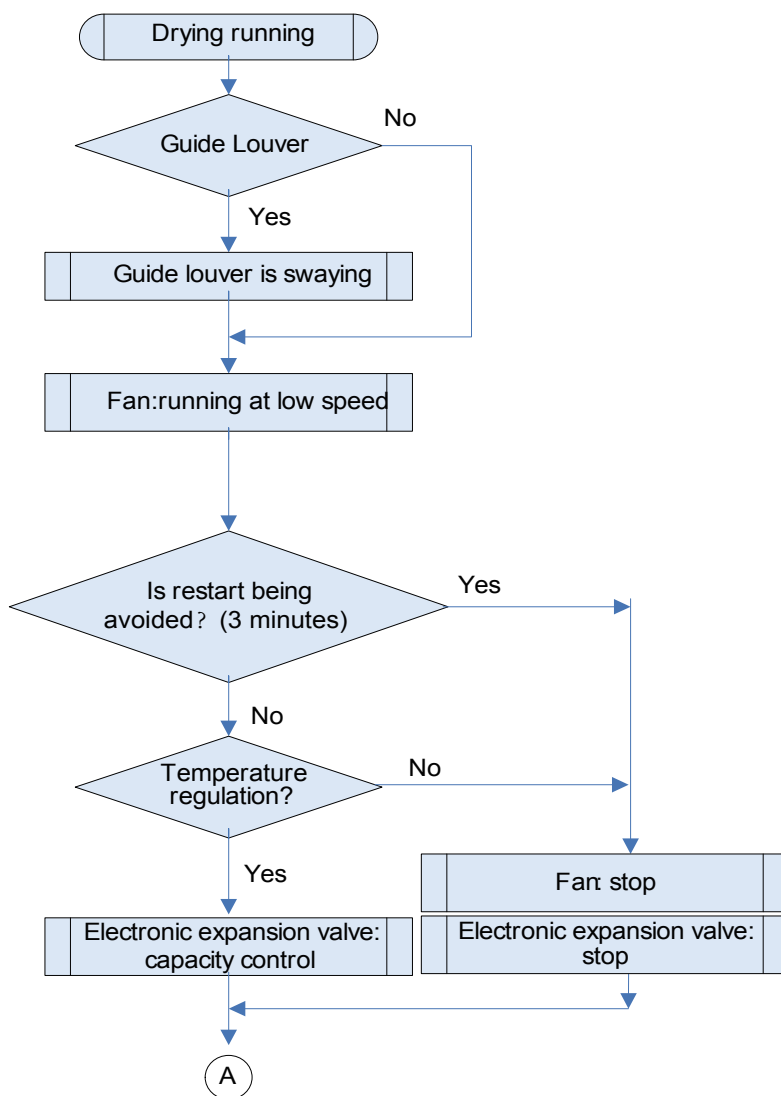

### 1.3 Operation Flow Chart of Outdoor Unit

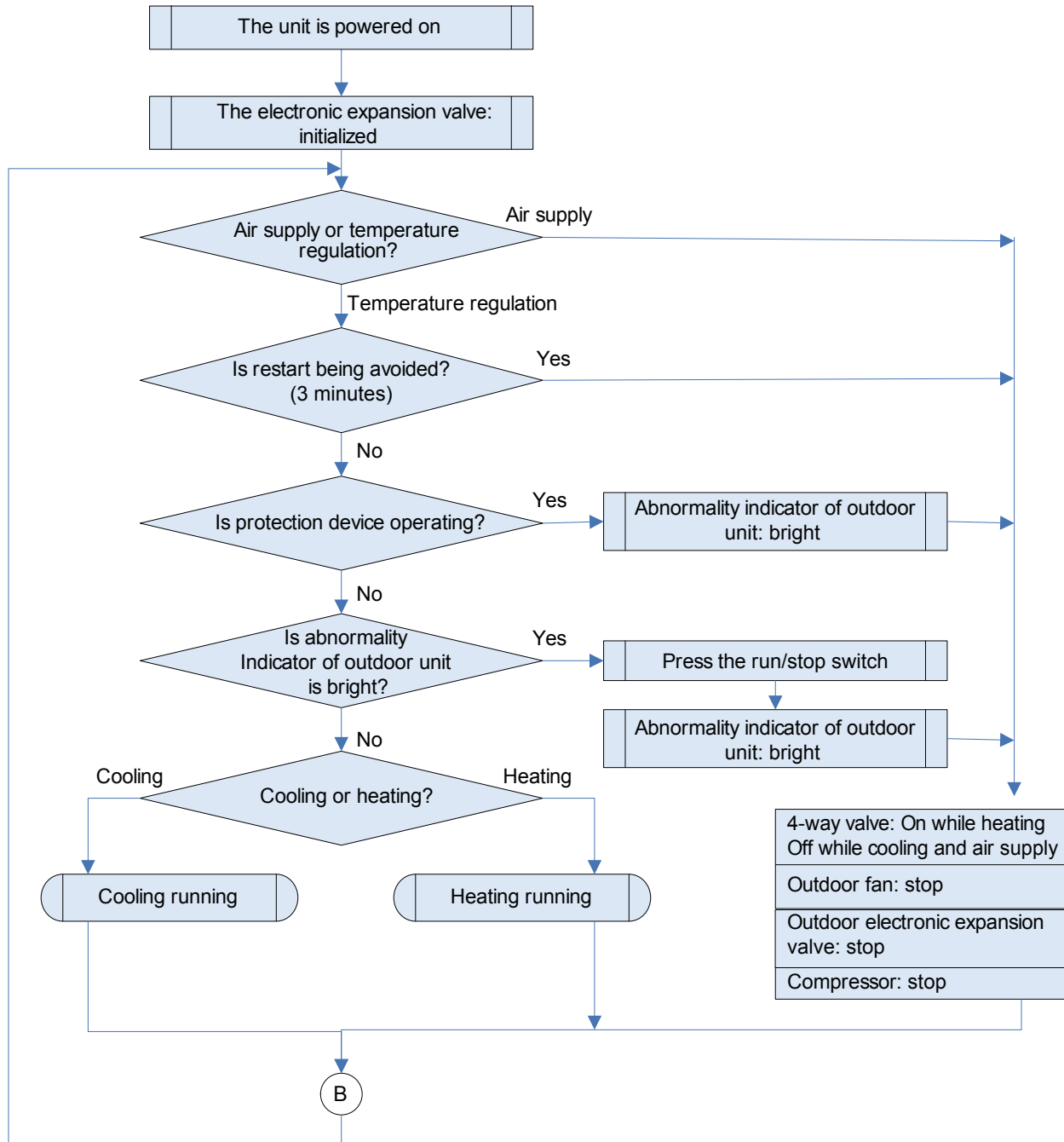

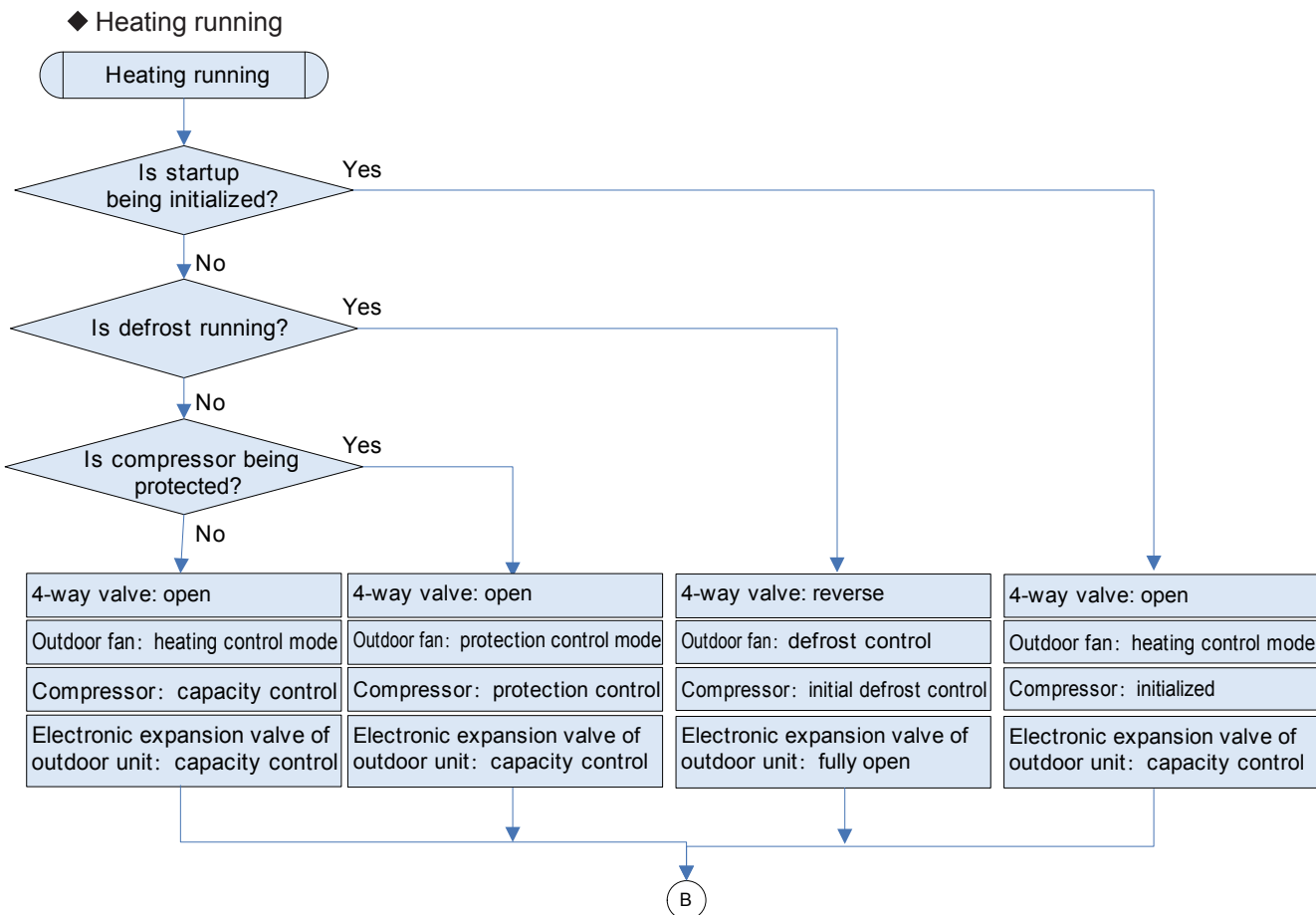
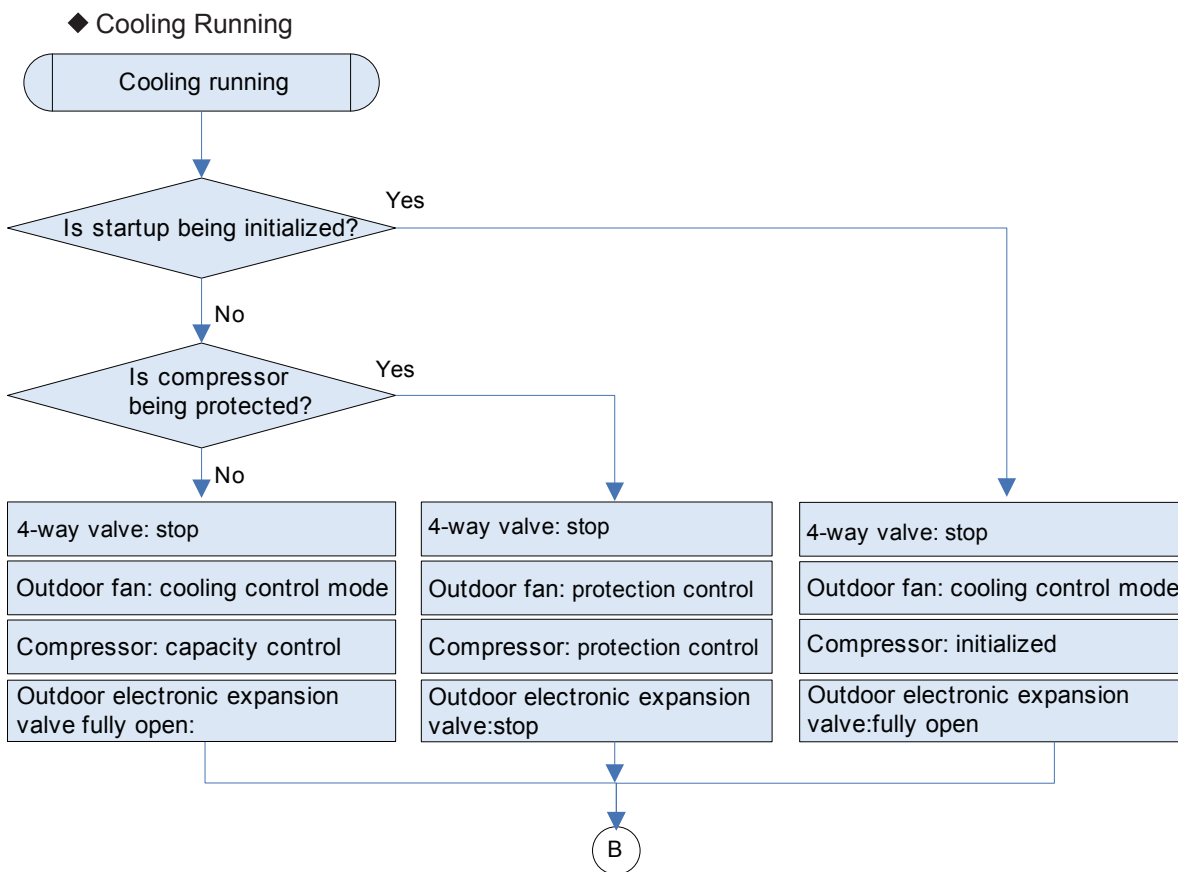



## 2 WIRELESS REMOTE CONTROLLER

This Service Manual contain two wireless remote controller, Y512 and YB1FA. Y512 is applicable to Cassette Type and Duct type. YB1FA m is applicable to Mounted Wall Type and Floor Ceiling Type.

### 2.1 Wireless Remote Controller Y512



#### NOTE!

- ◆ Make sure that there is no obstruction between the remote control and the signal receptor.
- ◆ The remote control signal can be received at the distance of up to about 10m.
- ◆ Don't drop or throw the remote control.
- ◆ Don't let any liquid flow into the remote control.
- ◆ Don't put the remote control directly under the sunlight or any place where is very hot.

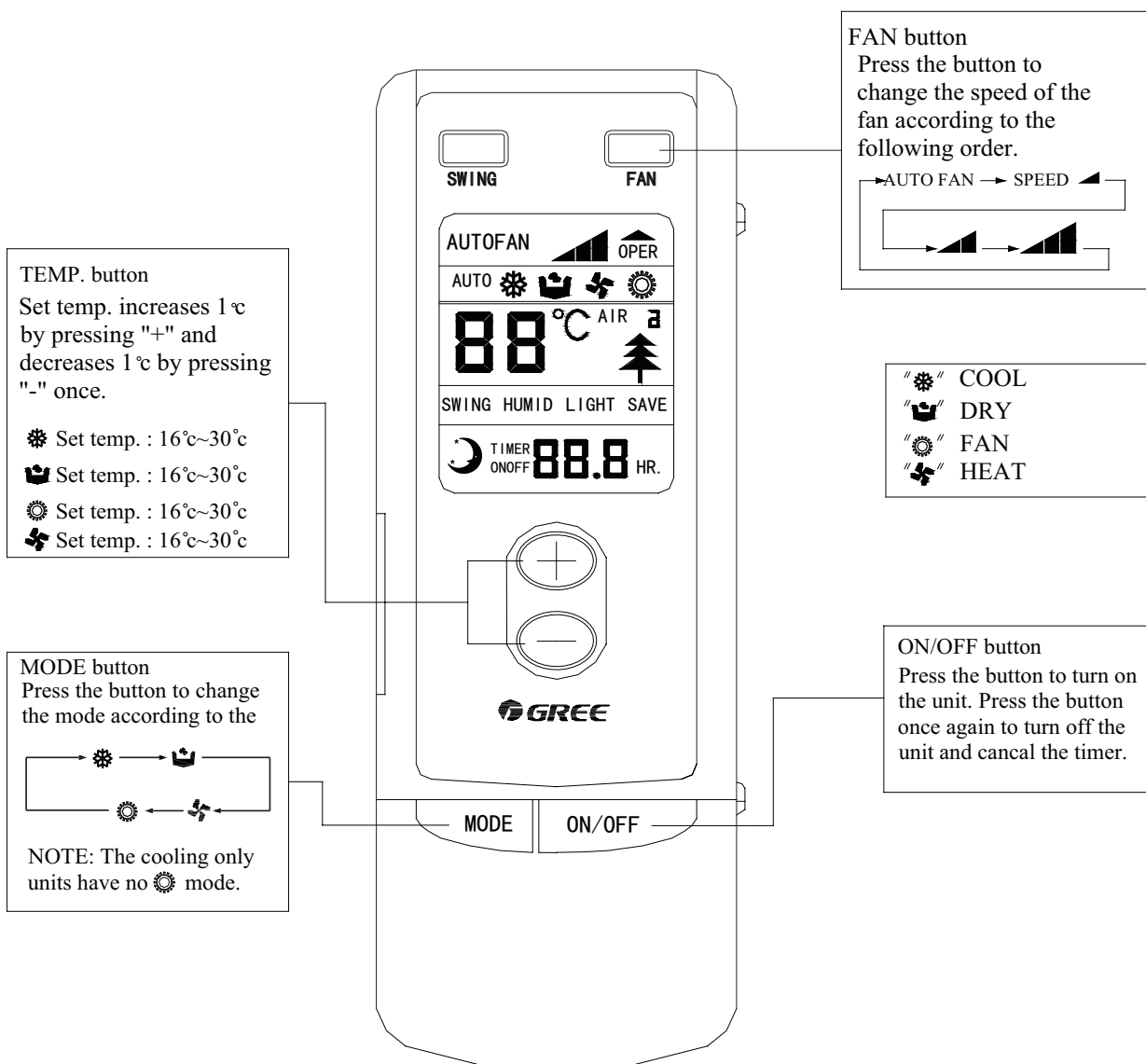

#### NOTE!

After every indoor unit received the turn off signal, the fan and electric inflate valve will continue to work for 20-70mins to make use of the rest cool or rest heat, while for preparation for the next work. And this is normal phenomenon.

**NOTE!**

This type of remote control is a kind of general use remote control that is suitable for several types (function) of air conditioner units. Please understand that the functions and buttons that are not suitable for this air conditioner will not be introduced.

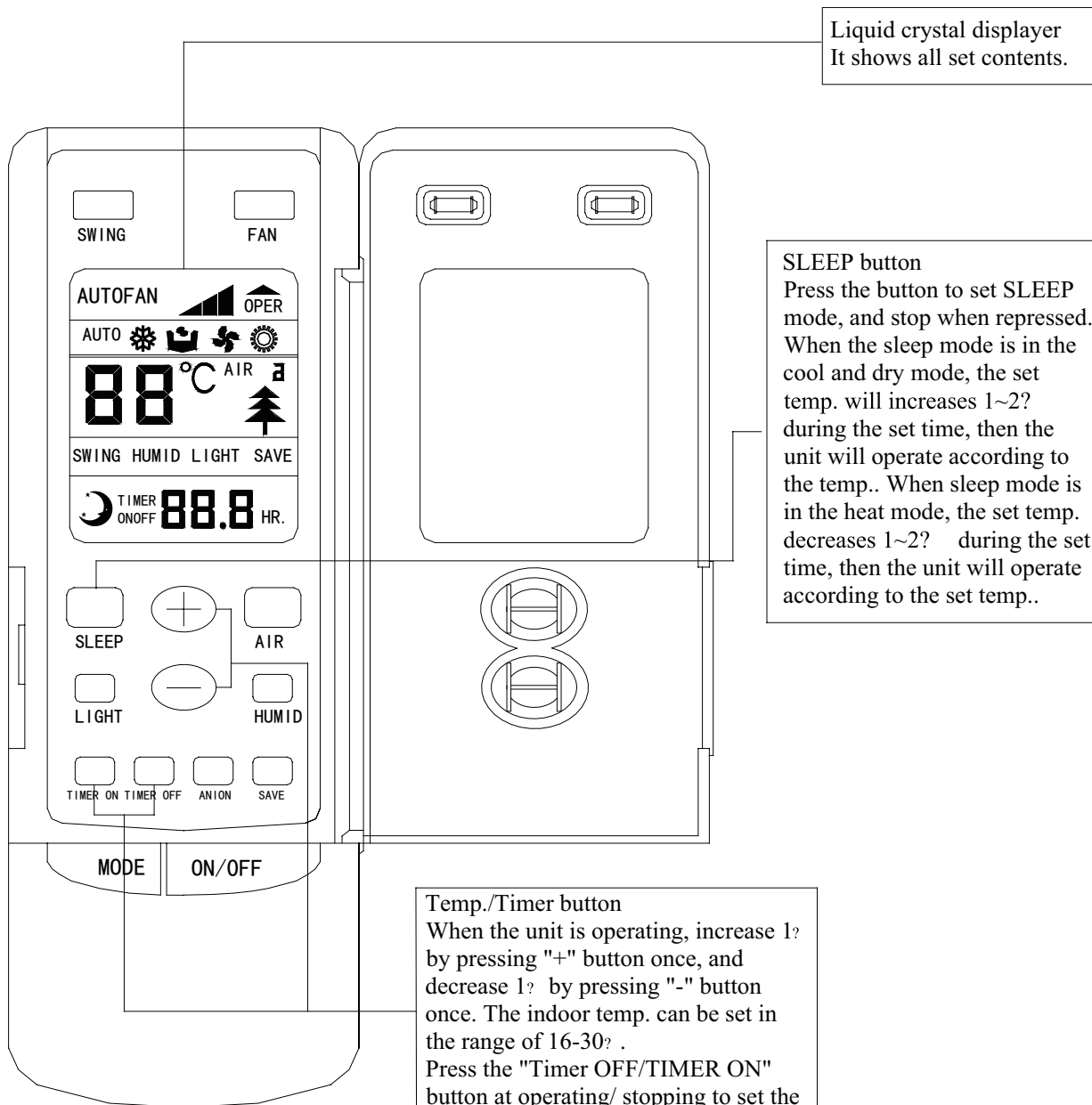

Liquid crystal display  
It shows all set contents.

**SLEEP button**  
Press the button to set SLEEP mode, and stop when repressed. When the sleep mode is in the cool and dry mode, the set temp. will increase 1~2° during the set time, then the unit will operate according to the temp.. When sleep mode is in the heat mode, the set temp. decreases 1~2° during the set time, then the unit will operate according to the set temp..

**Temp./Timer button**  
When the unit is operating, increase 1° by pressing "+" button once, and decrease 1° by pressing "-" button once. The indoor temp. can be set in the range of 16-30° .  
Press the "Timer OFF/TIMER ON" button at operating/ stopping to set the off/on time. Press "Timer OFF/TIMER ON" once to increase 0.5 hour for the set time. The Max. value of setting time could be 24 hours, when repressed it the setting time will be canceled.

### 2.1.1 Operation procedure

#### Normal procedure

- 1) Press ON/OFF button after connected with the power, then the unit is operating.
- 2) Press MODE button to choose the need operation mode.
- 3) Press FAN button to set the fan speed.
- 4) Press +/- button to set the need temp.

#### Selectable procedure

- 5) Press SLEEP mode to set the sleep state.
- 6) Press TIMER OFF button to set the set time.

#### NOTE:

When the operating mode selected by the indoor unit is clash with the one selected by the outdoor unit, the remote controller will display the operating clash after 5 seconds and the power light will flicker, then the indoor unit turns off. At this time, the units will become normal after the operating mode of the indoor unit is changed to cooperate with the outdoor unit. Cool mode can cooperate with dry mode, and fan mode can cooperate with any mode.

### 3.1.2 How to insert batteries

Two batteries (Two AAA dry-cell batteries) are used by the remote control

- 1) Remote the cover from the back of the remote control downward, take out the worn batteries and insert two new ones (Make sure the two poles are correct)
- 2) Re-attach the cover.

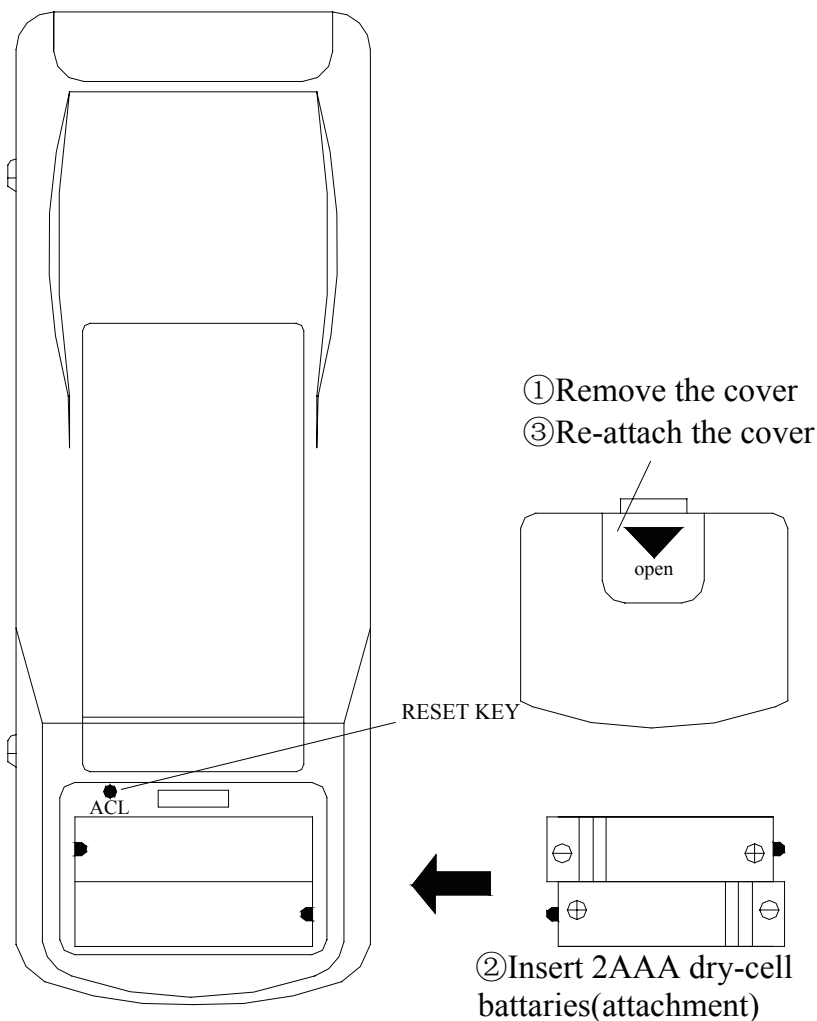

- 1) All the prints and code no. will be showed on the displayer after the insert of batteries. The remote control can be operated after 10sec.
- 2) The lifetime of the batteries is about one year.
- 3) Don't confuse the new and worn or different types of batteries.
- 4) Remove batteries when the remote control is not in use for a longtime to avoid mal-function caused by liquid leakage.
- 5) The remote control should be placed about 1m or more from the TV set or any other electric appliances.
- 6) The remote control should be used in the receivable range (the reception range is 10m)
- 7) When the remote control can not be controlled in the situation of inserted batteries, please remove the back cover and press "ACL" button to make it normal.

## 2.2 Wireless Remote Controller YB1FA

### 2.2.1 Names and functions of wireless remote control

**NOTE:**

Be sure that there are no obstructions between receiver and remote controller; Don't drop or throw the remote control; Don't let any liquid in the remote control and Note: Be sure that there are no obstructions between receiver and remote controller; Middle fan put the remote control directly under the sunlight or any place where is very hot.

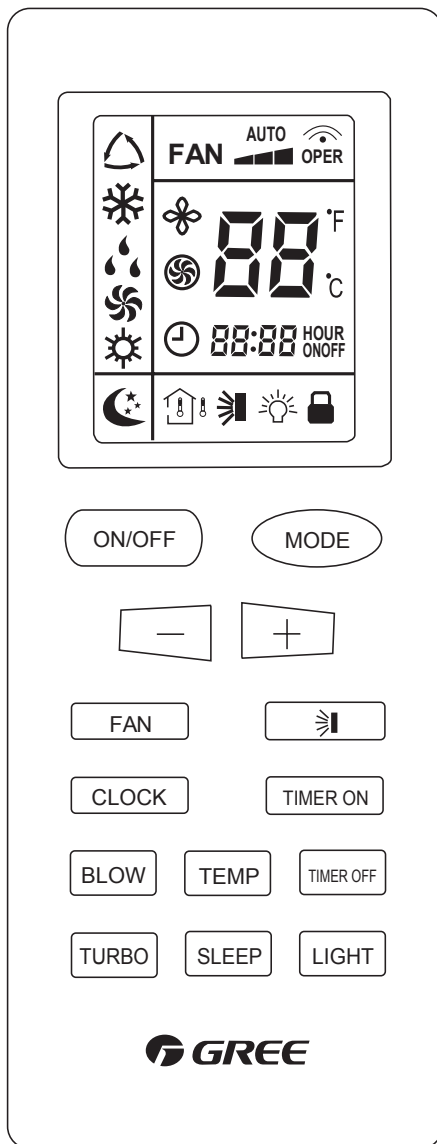

◆ ON/OFF

Press this button, the unit will be turned on, press it once more, the unit will be turned off. When turning on or turning off the unit, the Timer, Sleep function will be canceled, but the presetting time is still remained.

◆ MODE

Press this button, Auto, Cool, Dry, Fan, Heat mode can be selected circularly. MODE button MODE Auto mode is default while power on. Under Auto mode, the temperature will not be displayed; Under Heat mode, the initial value is 28°C (82 °F). ; Under other modes, the initial value is 25°C (77 °F).

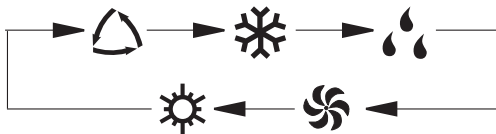

◆ SLEEP

Press this button, Sleep On and Sleep Off can be selected. After powered on, Sleep SLEEP button SLEEOff is defaulted. After the unit is turned off, the Sleep function is canceled. After Sleep function set up, the signal of Sleep will display. In this mode, the time of timer can be adjusted. Under Fan and Auto modes, this function is not available.

◆ FAN

Press this button, Auto, Low, Middle, High speed can be circularly selected. After FAN button FAN powered on, Auto fan speed is default. Under Dehumidify mode, Low fan speed only can be set up.

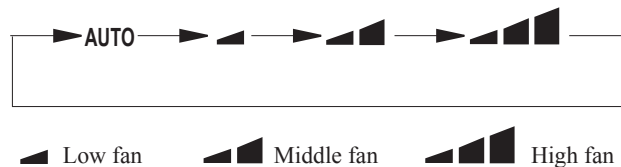

◆ CLOCK

Press this button, the clock can be set up, signal ⌚ blink and display. Within 5 CLOCK button CLOCK seconds, the value can be adjusted by pressing + or - button, if continuously press this button for 2 seconds above, in every 0.5 seconds, the value on ten place of Minute will be increased 1. During blinking, repress the Clock button, signal ⌚ will be constantly displayed and it denotes the setting succeeded. After powered on, 12:00 is defaulted to display and signal ⌚ will be displayed. If there is signal ⌚ be displayed that denotes the current time value is Clock value, otherwise is Timer value.

◆ LIGHT

Press this button at unit On or Off status, Light On and Light Off can be set up. LIGHT button LIGHT After powered on, Light On is defaulted.

Notice: This is a general use remote controller, it could be used for the air conditioners with multifunction; For some function, which the model doesn't have, if press the corresponding button on the remote controller that the unit will keep the original running status.

◆ BLOW

Press this button, can turn on or turn off the drying. In Cool and Dehumidifying mode, this button, "BLOW" will be concealed, at this time the Blow function is turned off. After powered on, Blow OFF is defaulted. When operating the ON/OFF button, or switching mode to Cool or Dehumidifying mode, the Blow function will keep the original status. If unit is turned off, Blow OFF only can be set up and send the signal. In Auto, Fan as well as Heat mode, Blow function can not be set up and there is no "BLOW" displaying. Press this button and will display "BLOW", at this time the Blow is turned on. If repress this button, "BLOW" will be concealed, at this time the Blow function is turned off. After powered on, Blow OFF is defaulted. When operating the ON/OFF button, or switching mode to Cool or Dehumidifying mode, the Blow function will keep the original status. If unit is turned off, Blow OFF only can be set up and send the signal. In Auto, Fan as well as Heat mode, Blow function can not be set up and there is no "BLOW" displaying.

◆ -

Presetting temperature can be decreased. Press this button, the temperature can be - button-set up, continuously press this button and hold for two seconds, the relative contents can quickly change, until unhold this button and send the order that the °C ( °F) signal will be displayed all the time. The temperature adjustment is unavailable under the Auto mode, but the order can be sent by if pressing this button.

◆ +

For presetting temperature increasing. Press this button, can set up the temperature, when unit is on. Continuously press and hold this button for more than 2 seconds, the corresponding contents will be changed rapidly, until unpress the button then send the information, °C ( °F) is displaying all along. In Auto mode, the temperature can not be set up, but operate this button can send the signal. Centigrade setting range :16-30; Fahrenheit scale setting range 61-86.

◆ TEMP

Press this button, could select displaying the indoor setting temperature or indoor ambient temperature. When the indoor unit firstly power on it will display the setting temperature, if the temperature's displaying status is changed from other status to "⌘", displays the ambient temperature, 5s later or within 5s, it receives other remote control signal that will return to display the setting temperature. If the users haven't set up the temperature displaying status, that will display the setting temperature. (This function is applicable to partial of

models)

After powered on, the setting temperature displaying is defaulted, (according to customers requirements to display, if there is no requirement that will default to display the presetting temperature and there is no icon displayed on wireless remote control). Press this button, (When displaying ), will display presetting temperature; (when displaying ) will display indoor ambient temperature, TEMP button current displaying status will not be changed. If current displays indoor ambient temperature, if received the other remote control signal, it will display presetting temperature, 5s later, will back to display the ambient temperature. (This function is applicable to partial of models)

◆ TURBO

In Cool or Heat mode, press this button can turn on or turn off the Turbo function. After turned on the Turbo function, its signal will be displayed. When switching the mode or changing fan speed, this function will be canceled automatically.



Press this button, to set up swing angle, which circularly changes as below:



This is a universal use remote controller. If remote controller sends the following three kinds of status that the swing status of main unit will be:



When the guide louver start to swing up and down, if turn off the Swing, the air guide louver will stop at current position. which indicates the guide louver swings up and down between that all five positions.

◆ TIMER ON

Timer On setting: Signal "ON" will blink and display, signal will conceal, the numerical section will become the timer on setting status. During 5 seconds blink, by pressing + or - button to adjust the time value of numerical section, every press of that button, the value will be increased or decreased 1 minute. Hold pressing + or - button, 2 seconds later, it quickly change, the way of change is: During the initial 2.5 seconds, ten numbers change in the one place of minute, then the one place is constant, ten numbers change in the tens place of minute at 2.5 seconds speed and carry. During 5s blink, press the Timer button, the timer setting succeeds. The Timer On has been set up, repress the timer On button, the Timer On will be canceled. Before setting the Timer, please adjust the Clock to the current actual time.

◆ TIMER OFF

Once press this key to enter into TIMER OFF setup, in which case the TIMER OFF icon will blink. The method of setting is the same as for TIMER ON.

2.2.2 Guide for operation- General operation

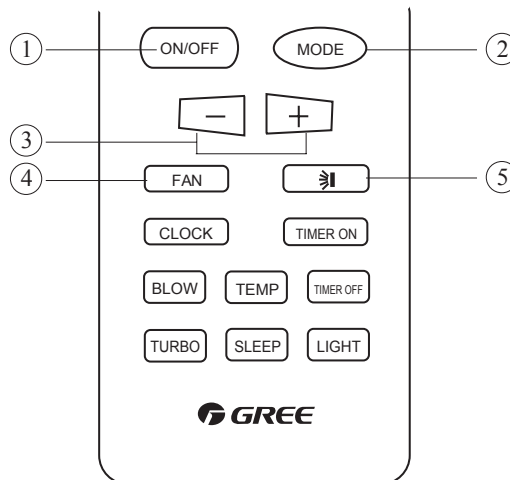

- 1) After powered on, press ON/OFF button, the unit will start to run.(Note: When it is powered off, the guide louver of main unit will close automatically.)
- 2) Press MODE button, select desired running mode, or press COOL or HEAT mode to enter into the corresponding operation directly.
- 3) Pressing + or - button, to set the desired temperature. (It is unnecessary to set the temp. at AUTO mode.)
- 4) Pressing FAN button, set fan speed, can select AUTO FAN, LOW, MID and HIGH.
- 5) Pressing  button, to select the swing.

### 2.2.3 Guide for operation- Optional operation

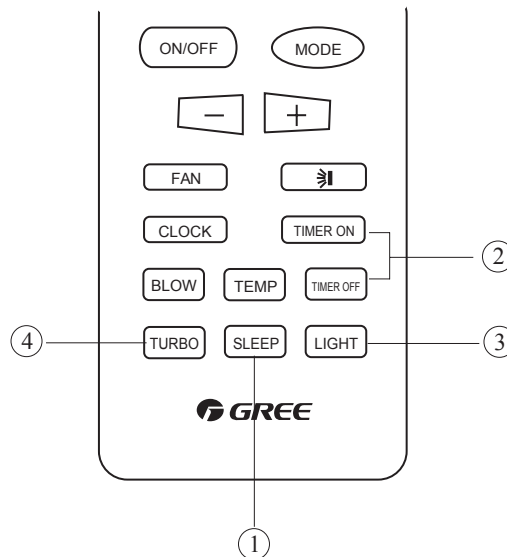

- 1) Press SLEEP button, to set sleep.
- 2) Press TIMER ON and TIMER OFF button, can set the scheduled timer on or timer off.
- 3) Press LIGHT button, to control the on and off of the displaying part of the unit (This function may be not available for some units).
- 4) Press TURBO button, can realize the ON and OFF of TURBOfunction.

### 2.2.4 Introduction for special function

#### ◆ About blow function

This function indicates that moisture on evaporator of indoor unit will be blowed after the unit About blow functionis stopped to avoid mould.1. Having set blow function on: After turning off the unit by pressing ON/OFF button indoorfan will continue running for about 10 min. at low speed. In this period, press blow button to stop indoor fan directly.2. Having set blow function off: After turning off the unit by pressing ON/OFF button, the complete unit will be off directly.

#### ◆ About AUTO RUN

When AUTO RUN mode is selected, the setting temperature will not be displayed on the LCD, the unit will be in accordance with the room temp. automatically to select the suitable running method and to make ambient comfortable.

#### ◆ About turbo function

If start this function, the unit will run at super-high fan speed to cool or heat quickly so thatthe ambient temp. approaches the preset temp. as soon as possible.



#### ◆ About Blow over heat (This function is applicable to partial of models)

When the unit is running in Heat mode or Auto Heat mode, compressor and indoor fan is running,to turn the unit off, the compressor, outdoor fan will stop running. The upper and lower guide boardrotate to horizontal position, then the indoor fan will run at low fan speed, 10s later, the unit will turn off.

#### ◆ About lock

Press + and - buttons simultaneously to lock or unlock the keyboard. If the remote controller is locked, the icon  will be displayed on it, in which case, press any button, the mark will flicker for three times. If the keyboard is unlocked, the mark will disappear.

◆ About swing up and down

1. Press swing up and down button continuously more than 2s, the main unit will swing back and forth from up to down, and then loosen the button, the unit will stop swinging and present position of guide louver will be kept immediately. 2. Under swing up and down mode, when the status is switched from off to , if press this button again 2s later,  status will switch to off status directly; if press this button again within 2s, the change of swing status will also depend on the circulation sequence stated above.

◆ About switch between Fahrenheit and Centigrade

Under status of unit off, press MODE and - buttons simultaneously to switch °C and °F.

◆ About new function of defrosting

It indicates: after starting this function by remote controller and the unit has been under defrost status, if turn off the unit by remote controller, the unit will not stop defrosting until it is finished; if change setting mode by remote controller, the function, which is set last time, won't be carried out until defrosting finished. Operation of this function on or off: If remote controller is under off status, press mode button and blow button simultaneously in order to enter or cancel this new function. If the unit is under defrost mode, dual eight position on remote controller will display H1. If switch to heat mode, the position will display H1, which flickers for 5s, in which case, press +/- button, H1 will disappear and setting temp. be displayed. After remote controller is powered on, the new defrost function will be defaulted to be closed.

### 2.2.5 Changing batteries and notices

- 1) Slightly to press the place with , along the arrowhead direction to push the back cover of wireless remote control. (As show in figure)
- 2) Take out the old batteries. (As show in figure)
- 3) Insert two new AAA1.5V dry batteries, and pay attention to the polarity. (As show in figure)
- 4) Attach the back cover of wireless remote control. (As show in figure)



**NOTE:**

- ◆ When changing the batteries, do not use the old or different batteries, otherwise, it can cause the malfunction of the wireless remote control.
- ◆ If the wireless remote control will not be used for a long time, please take them out, and don't let the leakage liquid damage the wireless remote control.
- ◆ The operation should be in its receiving range.
- ◆ It should be placed at where is 1m away from the TV set or stereo sound sets.
- ◆ If the wireless remote control can not operate normally, please take them out, after 30s later and reinsert, if they cannot normally run, please change them.

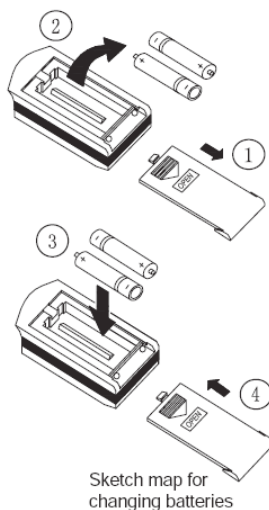



### 3 WIRED REMOTE CONTROLLER

#### 3.1 Wired Controller Z60351F,Z60151F,Z63351F,Z63151F

##### 3.1.1 Operation View

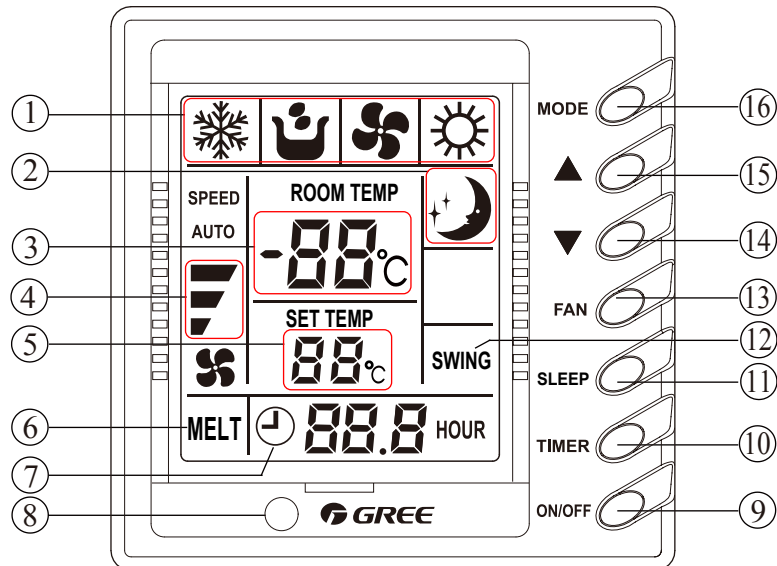

Fig.3.1.1.1 Wired Controller Z60351F,Z60151F

Various Components of Wired Remote Controller			
1	Operating mode display (Cool, Dry, Fan, Heat)	9	On/Off button
2	Sleep mode display	10	Timer button
3	Environmental temp. display /Malfunction display	11	Sleep button
4	Fan control display (automatic, high, media, low)	12	Swing display
5	Set Temp. display	13	Fan control button
6	Defrosting display	14	Temp./ Timer decrease button
7	Timer display	15	Temp./ Timer increase button
8	Signal receptor	16	Mode button

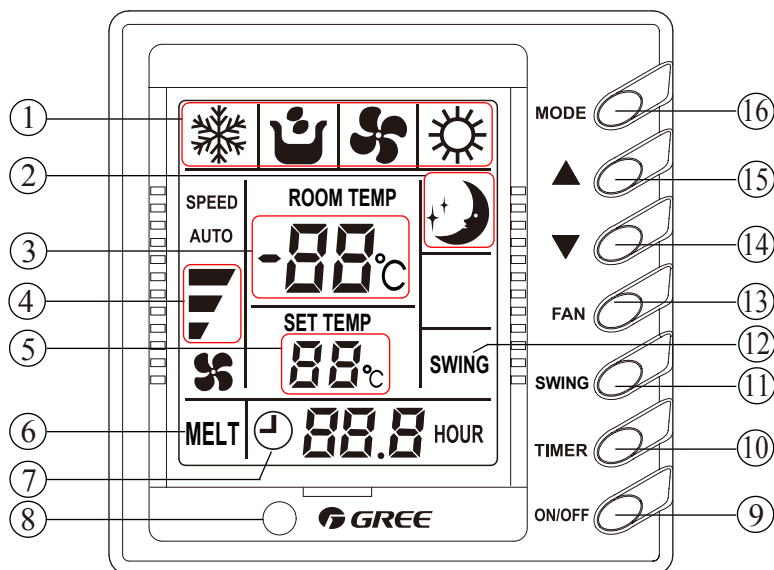

Fig3.1.2.2 Wired Controller Z63351F,Z63151F

Every part of wired remote controller			
1	Operating mode display (Cool, Dry, Fan, Heat)	9	On/Off button
2	Sleep mode display	10	Timer button
3	Environmental temp.display / Malfunction display	11	Swing button
4	Fan control display (automatic, high, media, low)	12	Swing display
5	Set Temp. display	13	Fan control button
6	Defrosting display	14	Temp. / Timer reducing button
7	Timer display	15	Temp. / Timer rising button
8	Signal receptor	16	Mode button

### 3.1.2 Dimension

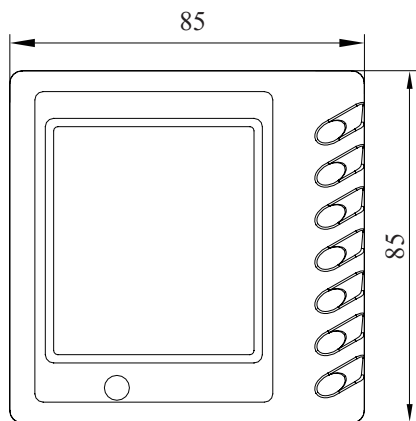
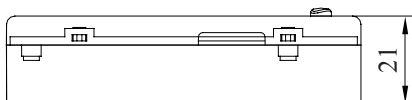

Fig.3.1.2.1 Outline Dimension of Wired Controller

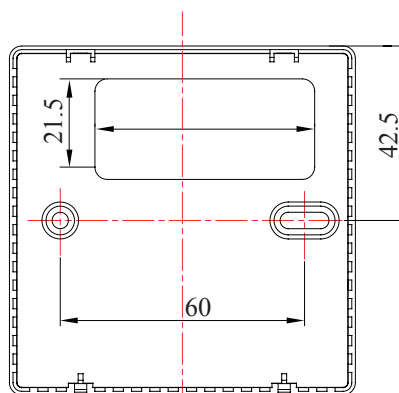

Fig.3.1.2.2 Installation Dimension of Wired Controller

### 3.1.3 Installation

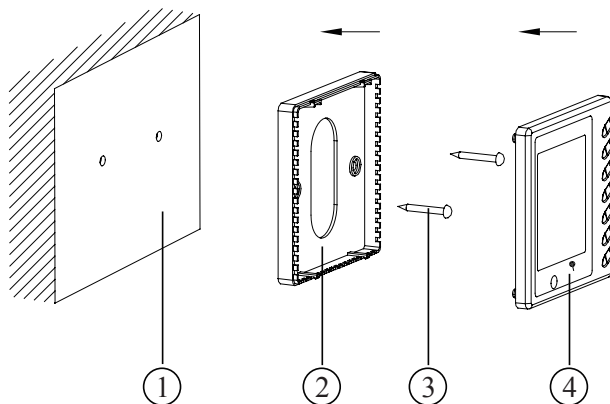

Fig.3.1.3

SN	1	2	3	4
Name	Casing base, installed into the wall	Controller Soleplate	Screw M4X25	Controller Panel

#### Notice for installation under the guidance of Fig.3.1.3

- ① . Cut off power supply before install the electrical components, it is forbidden to carry out the installation with power on;
- ② . Get one end of the 4 core communication cable, put it through the rectangular hole on the base board on the wire remote controller;
- ③ . Hold the base board of controller on the wall, then fix it to the wall with M4x25 screw;
- ④ . Plug the 4 core communication cable into the slot on the wired remote controller, then fix the controller panel with base board together;

## 3.2 Wired Controller XK02

### 3.2.1 Operation View

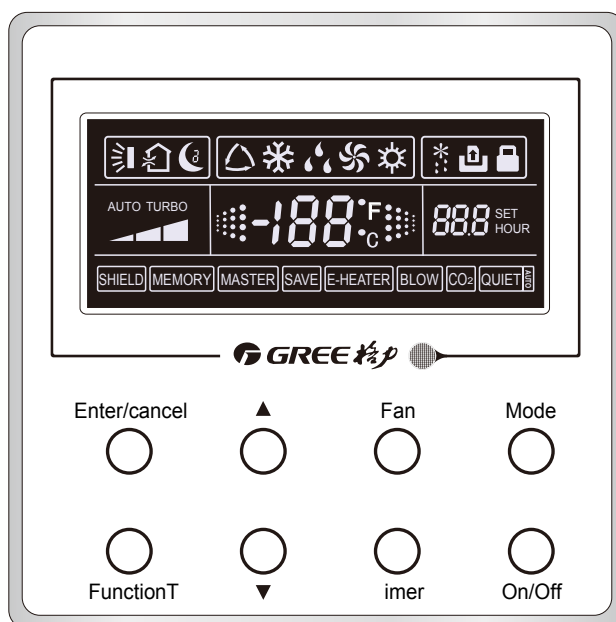



Fig.3.2.1.1

Denotation	Name	Function
	Swing	Swing function
	Sleep	Sleep states (3 types: sleep 1, sleep2 and sleep 3)
	Running mode	Running modes of the indoor unit (Cooling, Dry, Fan and Heating)
	Cooling	Cooling mode
	Dry	Dry mode
	Fan	Fan mode
	Heating	Heating mode
	Defrost	Defrosting state
	Gate-control card	Gate control
	Lock	Lock state
	TURBO	Turbo state
	Speed	High, middle, low or auto fan speed of the indoor unit
	Twinkle	It blinks under on state of the unit without operation of any button.
	Temperature	Ambient/preset temperature value
	Timing	Timing state
	SHIELD	Shield state (buttons, temperature, On/Off, Mode or Save is shielded by the remote monitor).
	MEMORY	Memory state (The indoor unit resumes the original setting state after power failure and then power recovery)
	MASTER	Master wired controller
	SAVE	Energy-saving state
	E-HEATER	Electric auxiliary heating state
	BLOW	Blow state
	QUIET	Quiet state(two types: quiet and auto quiet)

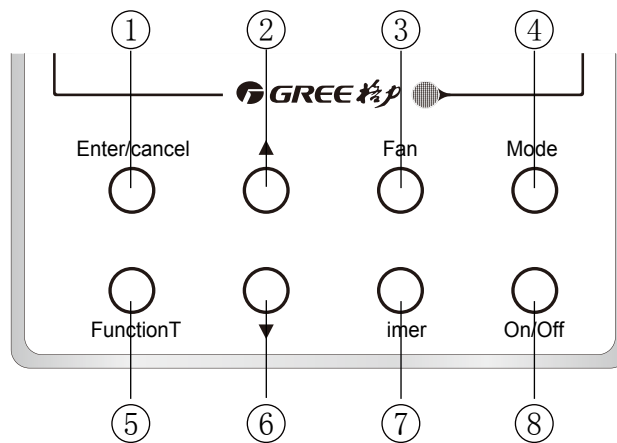

Fig.3.2.1.2

No.	Button(s)	Function(s)
1	Enter/cancel	1. Function selection and cancellation; 2. Press it for 5s to examine the outdoor ambient temperature.
2	▲	1. Running temperature setting of the indoor unit, range : 16~30°C 2. Timer setting, range:0.5-24hr 3. Switchover between quiet/auto quiet or among sleep1/ sleep2 / sleep 3
6	▼	
3	Fan	Setting of the high/middle/low/auto fan speed
4	Mode	Setting of the Cooling/Heating/Fan/Dry mode of the indoor unit
5	Function	Switchover among the functions of Swing/Sleep/Turbo/ Master/Save/E-heater/Blow /Quiet etc.
7	Timer	Timer setting
8	On/Off	Turn on/off the indoor unit
4 + 2	Mode + ▲	Press them for 5s under off state of the unit to enter/cancel the Memory function (If memory is set, indoor unit after power failure and then power recovery will resume the original setting state. If not, the indoor unit is defaulted to be off after power recovery. Memory off is default before delivery.)
3 + 6	Fan + ▼	By pressing them at the same time under off state of the unit, ❄ will be displayed on the wired controller for the cooling only unit, while ❄ will be displayed on the wired controller for the cooling and heating unit.
2 + 6	▲ + ▼	Upon startup of the unit without malfunction or under off state of the unit, press them at the same time for 5s to enter the lock state, in which case, any other buttons won't respond the press. Repress them for 5s to quit this state.
4 + 5	Mode + Func	1. By pressing them under off state of the unit at the same time, the address of the wired controller will be displayed at once; 2. By pressing them for 5s under off state of the unit at the same time, the address setting is available.
1 + 5	Enter/Cancel + Func	By pressing them simultaneously, the address of the master wired controller will be displayed.
2 + 5	▲ + Func	By pressing them for 5s under off state of the unit at the same time, the control of the master wired controller can be canceled.
4+6	Mode + ▼	When the unit is turned off, press them for 5 seconds simultaneously, display panel will switch between °C and °F.
5+6	Function+ ▼	In any conditions, press them for 5 seconds to review status. Under reviewing status, Mode changes to "00" in temp display area and press "▲"/"▼" to adjust the display. Timer display area will show the s/n of error and error code. The final error shown is the 5th error.

### 3.2.2 Dimension

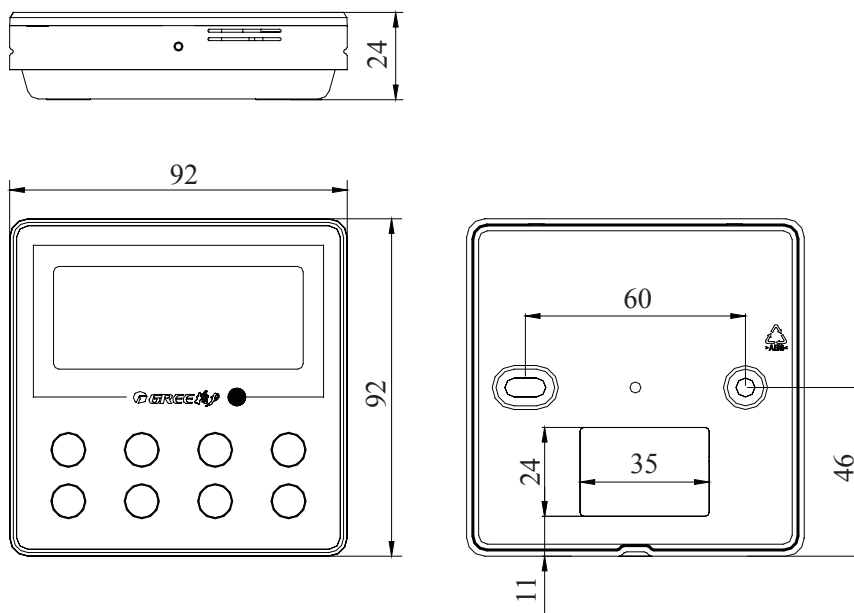

Fig.3.2.2

### 3.2.3 Installation of Wired Controller

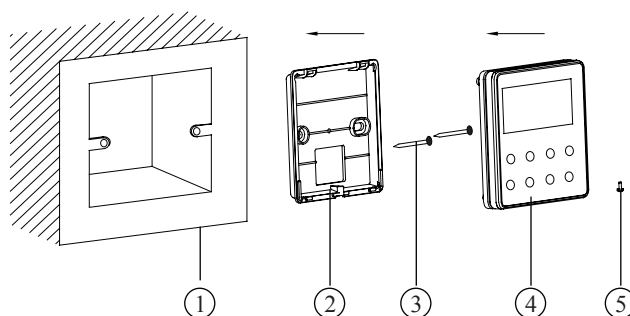

Fig.3.2.3

No.	1	2	3	4	5
Name	Socket housing installed in wall	Base plate of controller	Screw M4X25	Control Panel	Screw ST2.2X6.5

#### Notice for installation under the guidance of Fig.3.2.3

- ⑤ . Cut off power supply before install the electrical components, it is forbidden to carry out the installation with power on;
- ⑥ . Get one end of the 4 core communication cable, put it through the rectangular hole on the base board on the wire remote controller;
- ⑦ . Hold the base board of controller on the wall, then fix it to the wall with M4x25 screw;
- ⑧ . Plug the 4 core communication cable into the slot on the wired remote controller, then fix the controller panel with base board together;

## 4 REGIONAL CONTROLLER

### 4.1 Function

Region monitoring control and region wired control are the two main control functions for region controller.

Region monitoring controller can monitor or control 16 indoor units of a group for inquiry and single or centralized control.

Region wired controller can replace 1-16 selected wired controllers to uniformly set or control the indoor units.

Refer to Fig.4.1.1, Fig.4.1.2 about the Sketch map to the relation among the region controller, region monitoring controller and region wired controller.

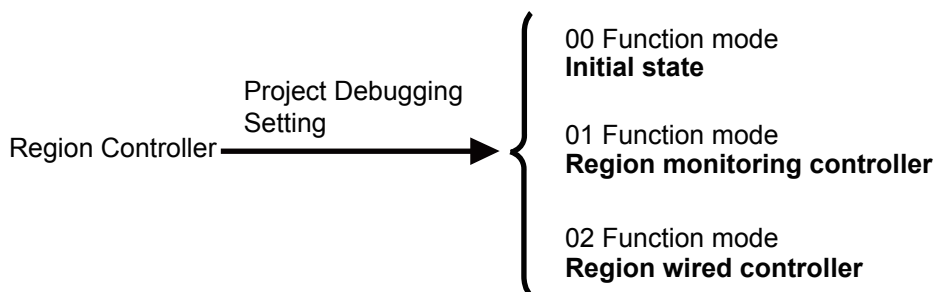

Fig.4.1.1

Before using, the controller functions must be selected by the personnel who performance the installation with the requirements of users. Please refer to Project Debugging Setting section for the details.

Note: If the controller is set to be region wired controller, the wired controller of the selected indoor unit must be removed.

The region controller can be matched with long-distance monitor. As a region monitoring controller, its control is subject to that of the long-distance monitor. In the same group, one of the region controllers can be used as region monitoring controller and matches one or more region wired controller which replace(s) one or more wired controller, in which case, the region monitoring controller can also monitor or control the region wired controller.

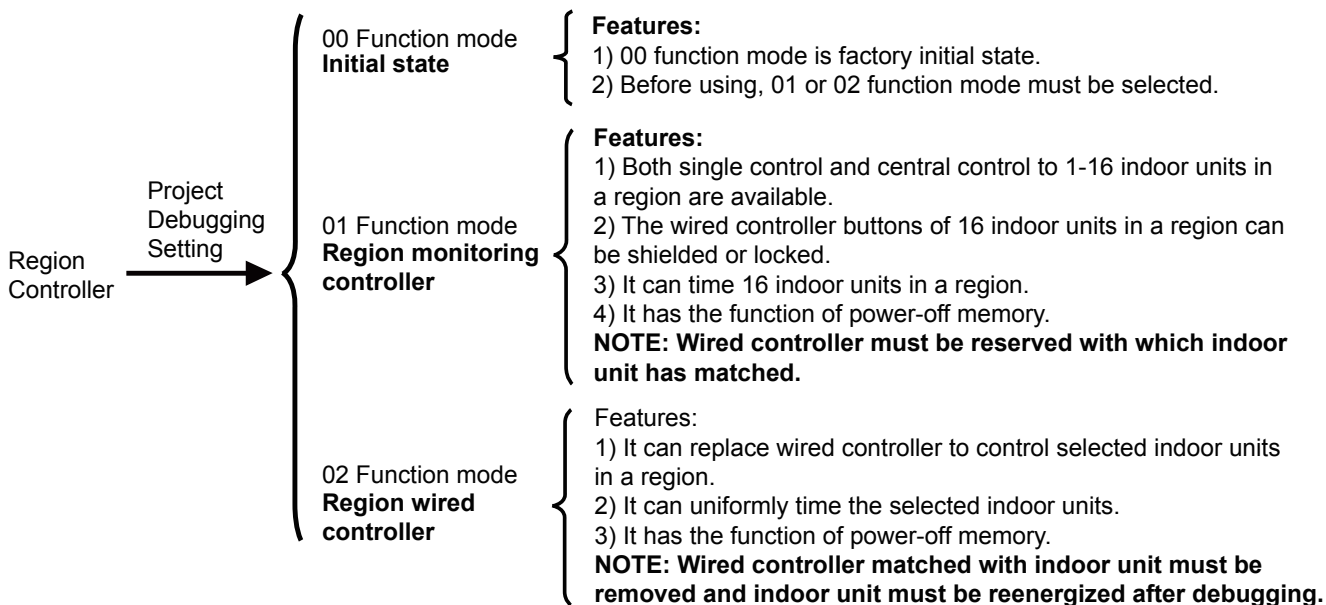

Fig.4.1.2 Sketch map to the relation among the region controller, region monitoring controller and region wired controller

## 4.2 Operation View

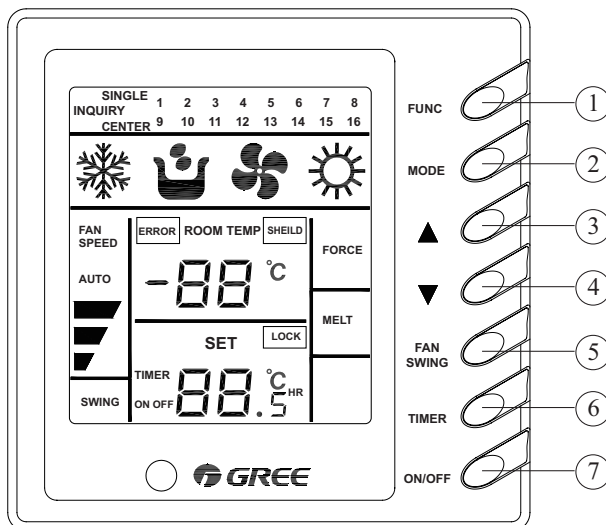

Fig.4.2

### Instruction to functions of buttons (Table 4.2)

No.	Name	Function
1	FUNC (FUNCTION)	A. Switch the control mode of inquiry/single/ central control. B. In central control status, give the central order by successively pressing FUNC button.
2	MODE	Set cooling/heating/fan/dry mode for indoor unit
3	▲	A. Inquiry status: cycle, increase or decrease No. of indoor units to easily inquire the status of each indoor unit. B. Single/Central control status: set running temp. of indoor unit, maximum is 30 °C and minimum is 16 °C. C. Timer setting status: increase or decrease the timer on/ off time, maximum is 24hr and minimum is 0.
4	▼	
5	FAN	A. Set the indoor fan speed of hi/mid/low/auto. B. Successively press FAN button to set on/off swing.
6	TIMER	A. Under single/central control mode, set on /off timer of selected indoor unit B. Under inquiry status, inquire the timer setting of the indoor unit with current address.
7	ON/OFF	Set ON/OFF of the indoor unit.
2MODE and 7 ON/OFF	Lock	Under single/central control, press MODE and ON/OFF buttons simultaneously to start/ stop the lock of operation to buttons of wired controller for selected indoor units.
2MODE and 6 TIMER	Shield mode	Under single/central control, press MODE and TIMER simultaneously to start/ stop the shield of operation to MODE button of wired controller for selected indoor unit.
4 ▼and 6 TIMER	Shielding Temp.	Under single/central control, press ▼ and TIMER simultaneously to start/ stop the shield of operation to Temp button of wired controller for selected indoor unit.
7 ON/OFF and 6 TIMER	Shielding ON/OFF	Under single/central control, press ON/OFF and TIMER simultaneously to start/ stop the shield of operation to ON/OFF button of wired controller for selected indoor unit.
2 MODE and 3 ▲	Memory mode	Refer to power-off memory function about the details.
4 ▼and 7 ON/OFF	Selection of function	A. Check the control mode of region monitoring controller / region wired controller B. Set the control mode of region monitoring controller / region wired controller

Note:

- ①. The characters with gray back ground indicate buttons. Following part is the same to it.
- ②. The time of single press of the button is more than 3s, which means successively-press.
- ③. There isn't the function that the region wired controller shields other indoor wired controller.



### 4.3 Display View

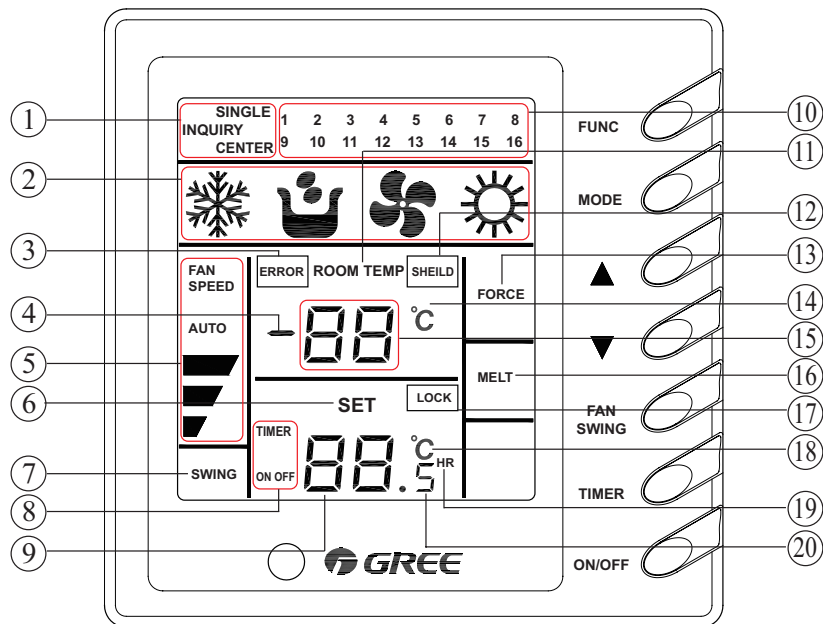

Fig.4.3

No.	Display name	Instruction to display
1	Control mode	Inquiry state, "INQUIRY" is displayed. Single control state, "SINGLE" is displayed. Centralized control state, "CENTER" is displayed.
2	Running mode	Each indoor unit running mode is displayed.
3	Error	"ERROR" is displayed during any malfunction to indoor or outdoor unit in a group.
4	-	"-" is displayed when there is no malfunction to selected indoor unit and the ambient temp. is below zero.
5	Fan speed display	Hi, mid, low or auto speed of indoor fan is displayed.
6	Set	"SET" blinks when the unit is on and commanded. "SET" is displayed when the unit is on without command.
7	Swing	Swing running of indoor unit is displayed.
8	Timer	"TIMER ON/OFF" is displayed when setting timer or inquiring timer state.
9	Setting temp. and timer time	During timer inquiry, integer of setting time of timer is displayed. During timer setting, integer of setting time of timer is displayed. Set temp. value is displayed when the unit is not during timer inquiry or setting.
10	No. of indoor unit	Under inquiry state, No. of online indoor units are displayed and No. of selected indoor unit will blink. Under single control state, only No. of selected indoor unit is displayed. Under centralized state, No. of all online indoor units are displayed.
11	Room temp.	"ROOMTEMP" is displayed for no malfunction, but isn't for malfunction.
12	Shield	Centralized controller A. Under inquiry state, "SHIELD" will be displayed when selected indoor unit is shielded. B. Under control state, "SHIELD" will be displayed during setting or giving the shield order. Region wired controller: "SHIELD" will be displayed when selected units are shielded during long-distance monitoring.
13	Force	"FORCE" is displayed when indoor unit is forced to run.
14	°C (room temp.)	"°C" is displayed when there is no malfunction.
15	Room temp. or error code	Room temp. value is displayed during no malfunction to selected indoor or outdoor unit. Error code is displayed during malfunction to selected indoor or outdoor unit.
16	Melt	"Melt" is displayed during defrosting.
17	Lock	Region monitoring controller A: Inquiry state: "LOCK" is displayed when selected indoor unit is locked. B: Control state: "LOCK" is displayed during setting or giving the lock order. Region wired controller: "LOCK" is displayed when selected unit is locked in long-distance monitoring.

18	°C (set temp.)	Set temp. value is displayed when the selected indoor unit is on and not in timer inquiry or setting status.
19	HR (hour)	"HR" is displayed during timer inquiry or setting.
20	.5	".5" is displayed when the timer time value includes 0.5 hr and the unit is during timer inquiry or setting.

Note:

- ①. Contents in the double quotation marks indicate the display in LCD. Following part is the same to it.
- ②. Online indoor units to Mini Centralized Controller indicate that in a region. Following part is the same to it.
- ③. No signal control function for region wired controller, and "SINGLE" won't be displayed either.

#### 4.4 Connection Between Controller and Unit

Insert the 4-core twisted pair line to wired controller, if which is with the indoor unit, into region controller wiring terminal CN1 (or CN2), and then connect the other wiring terminal CN2 (or CN1) with the main board of indoor unit.

If there is no wired controller with indoor unit, introduce a 4-core twisted pair line to indoor unit main board and connect it with region controller wiring terminal CN1 (or CN2).

**Note:**

Any main board of the indoor unit controlled by the region controller can be connected. If the region controller is used as a region wired controller, wired controller with the indoor unit must be removed.

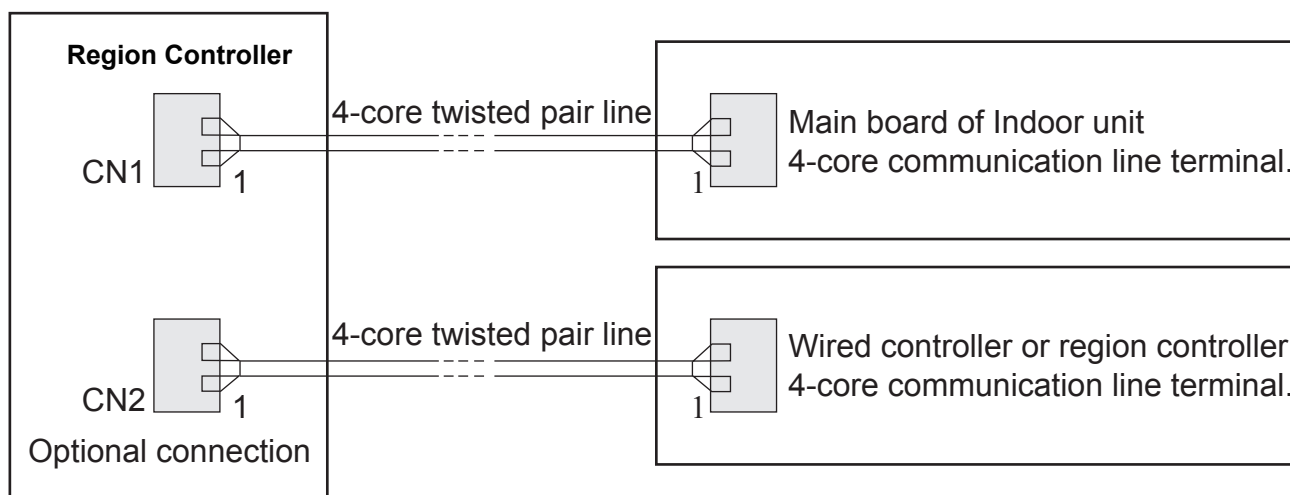

Fig.4.4 Power cords and communication lines for region controller

Before installation and connection, make sure the power supply is off. After installation and connection, check the connection result again to prevent loose or short.

There are 4 connection lines (included in the 4-core twisted pair line) to the controller, from CN1 or the upper and right CN2 to the upper they respectively are: Ground line (GND), communication line A (A), communication line B(B) and power cord (+12 v).



**Note:**

During following connection of wirings, pay special attention to them to avoid malfunction to units for electromagnetic interference.

- ④. Keep the signal lines or wirings (communication) of region controller or wired controller at least 20 cm from the power cords or connecting lines between indoors and outdoors to prevent abnormal communication.
- ⑤. Shielding twisted pair line must be adopted as signal line or wiring (communication) once the unit is installed in the place where there is serious electromagnetic interference.

## 5 SMART ZONE CONTROLLER

### 5.1 Function

Simple centralized controller can connect to indoor units of 3 sets of VRF outdoor units. It can directly connect to 16 indoor units in a same network without adding communication module. It can search status of a indoor unit and display it by LCD. Controlled items are mode, timer, fan speed, temperature of a single unit, centralized setting and shield, etc.

### 5.2 Operation View



Fig.5.2

No.	Name	Function Description
1	Mode	It is used for the switchover among different modes
2	Fan	It is used to set the fan speed, high, medium, low or auto.
3	On/Off	It is used to set the on/off status of the indoor unit.
4	▲	1. Under the single/centralized control status:It is used to set the running temperature of the indoor unit with max.30°C anmin.16°C . 2. Under the timing setting status:It is used to set the timing period with max.24 hours and min.0 hour. 3. Under the clock setting status: it is used to set the hour (max.:23,min.:0) and minute (max.:59, min.: 0) of the clock.
5	▼	
6	Mon 1/9	
7	Tue 2/10	It is used for the switchover between unit 2 and unit 10; Under the timing or clock setting status, it indicates Tuesday.
8	Wed 3/11	It is used for the switchover between unit 3 and unit 11 Under the timing or clock setting status, it indicates Wednesday.
9	Thu 4/12	It is used for the switchover between unit 4and unit 12 Under the timing or clock setting status, it indicates Thursday.
10	Fri 5/13	It is used for the switchover between unit 5and unit 13 Under the timing or clock setting status, it indicates Friday.
11	Sat 6/14	It is used for the switchover between unit 6 and unit 14; Under the timing or clock setting status, it indicates Saturday.
12	Sun 7/15	It is used for the switchover between unit 7 and unit 15 Under the timing or clock setting status, it indicates Sunday.
13	8/16	It is used for the switchover between unit 8 and unit 16
14	Timer/Time	It is used to set the timing or on/off time of the selected indoor unit as well as to set the clock of the system.

15	Central	It is used for the switchover between single and centralized control modes.
16	Shield	It is used to deactivate some or all functions of a single or a group the indoor unit(s).
17	All on/off	It is used to start/stop all indoor units.

### 5.3 Display View

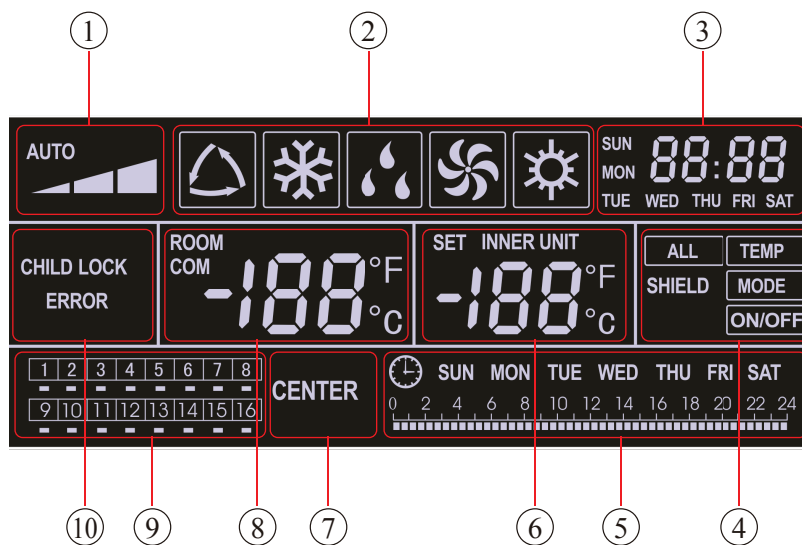

Fig.5.3

No.	Name	Description
1	Fan speed	It displays the fan speed of the indoor unit, high, medium, low and auto.
2	Running mode	It displays the running mode of the indoor unit, auto, cool, dry, fan and heat.
3	System clock	It displays the current time (hour and minute) in 24-hour time system and also the week day.
4	Shield	It displays the shield status, "ALL", "TEMP", "MODE" and 'On/Off'.
5	Weekly timer	It displays the timing period (unit: 0.5 hour) which will circulate every week.
6	Set temperature Indoor unit code	It displays the set temperature, indoor unit code (01-16), and symbols of Celsius and Fahrenheit scale.
7	Control mode	It displays "CENTER" under the centralized control mode and no display under the single control mode.
8	Ambient temperature Serial port	It displays the ambient temperature, serial port as well as symbols of Celsius and Fahrenheit scale.
9	Indoor unit code On/off status	Numbers indicate the indoor unit codes which will be displayed when the corresponding indoor unit is online; "□" indicates the on/off status of the indoor unit, its flashing for "on" or else for "off"
10	Error Child lock	It displays the error codes when some error(s) arises and also "CHILD LOCK" when this function is activated.

## 5.4 Network Topological Diagram

### 5.4.1 Network of Simple Centralized Controller:

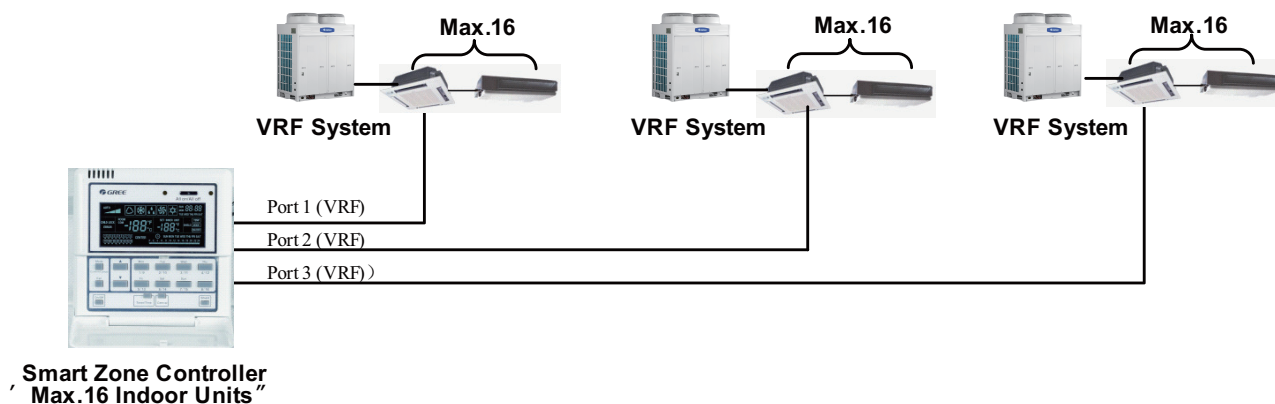

Fig. 5.4.1

**Note:** Simple centralized controller can connect to maximum 3 sets of VRF outdoor units but the indoor unit which it connects can't exceed 16 sets.

### 5.4.2 Relationship of simple centralized controller, remote monitoring and centralized controller:

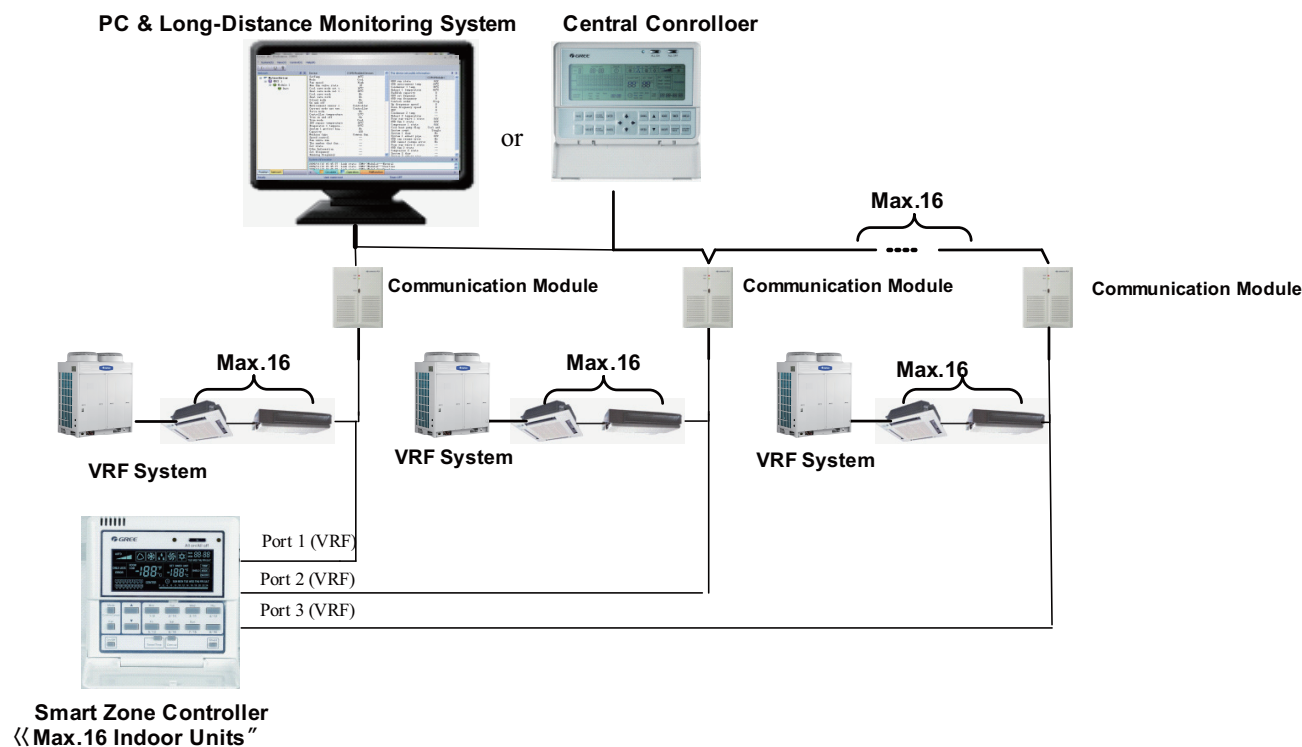

Fig. 5.4.2

**Note:** simple centralized controller can compatible to centralized controller/remote monitoring. But centralized controller/remote monitoring has the priority.

## 5.5 Installation and Debugging

### 5.5.1 Installation

#### 5.5.1.1 Installation Dimension Diagram

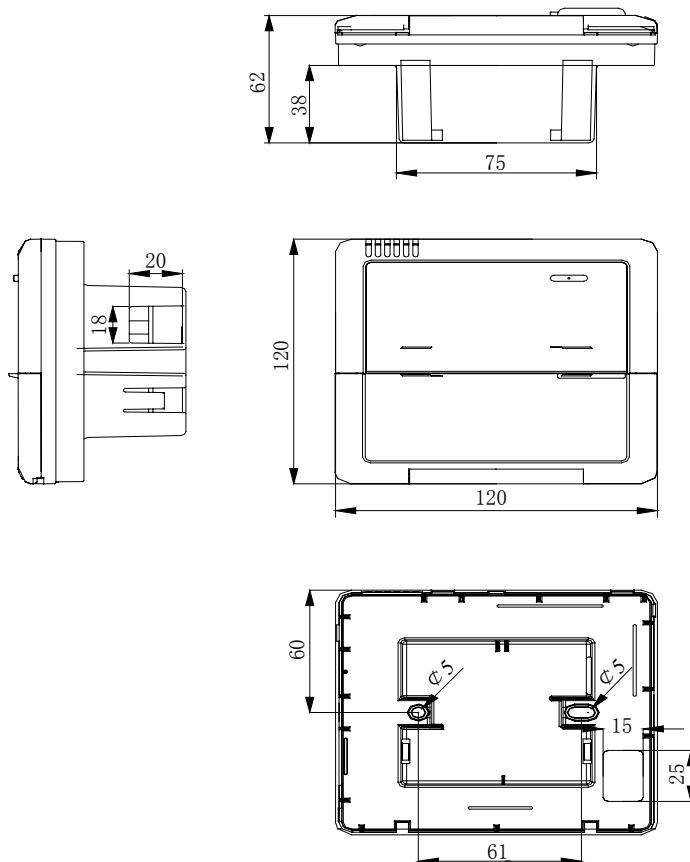

Fig.5.5.1 Installation Dimensions Diagram

#### 5.5.1.2 Interfaces

See Fig.5.5.2 for the interfaces of the display board and see Fig.5.5.3 for the interfaces of the power supply module.

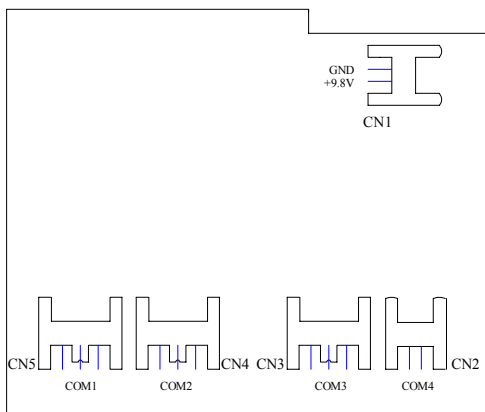

Fig.5.5.2 Interfaces of the Display Board

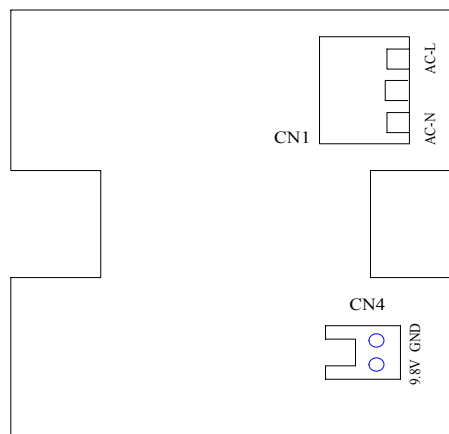

Fig.5.5.3 Interfaces of the Power Supply Module Board

a. Interface of the Power Supply

The interface CN1 of the power supply module board is for the connection board of the external power cord, the terminal AC-N for the neutral line, the terminal AC-L for the live line and the middle terminal keeps open.

The interface CN4 of the power supply module board which is for the power supply of the display board, is connected with the interface CN1 of the display board through the two-core wire provided by Gree.

b. Communication Interface

The interfaces CN2, CN3, CN4 and CN5 of the display board are for communication, and CN2 namely COM4 is for the communication of the duct type unit (2-pin); CN5, CN4, CN3 namely COM1, COM2, COM3 respectively are for the communication of the multi VRF system (3-pin).

5.5.1.3 Preparation and Connection of the Communication Line

a. The communication line between the centralized controller and the unit should be prepared by the user according to the actual project.

b. Preparation and connection of the communication line for the multi VRF system

①. One three-core communication line is needed to connect one set of multi VRF system to one interface (COM1, COM2 or COM3) of the smart zone controller.

②. One end of the communication line is connected with the smart zone controller and the other is connected with the three-pin socket of the indoor unit.

c. Preparation and connection of the communication line for the duct type unit

①. The communication line for the duct type unit is the two-core line provided by Gree (one end is the two-core head and the other end is the crystal head, code: 40113325)

②. Where there are N sets of duct type units, then N+1 communication lines are needed.

③. Connect the two-core head of one communication line to the port COM4 of the smart zone controller and connect the two-core heads of N communication lines to the two-pin socket of the wired controller of the duct type unit.

④. The user can prepare the extension line and connect the wires inside the crystal head according to the actual need.

**Note: one set of Multi VRF system consists of one multi VRF outdoor unit and one or more than one multi VRF indoor units. And one set of duct type unit consists of one duct type outdoor unit and one duct type indoor unit.**

5.5.1.4 Installation

The installation can proceed on when the installation location is selected and the installation steps are as follows:

a. Firstly make sure where to install the smart zone controller.

b. Embed the power supply box (2) as Fig.5.5.6 for the installation of the bottom case (3).

c. Connect the power cord and the communication line of the display board and then let both go through the power supply box (2).

d. Fix the bottom case on the power box (2) by screws.

e. Tidy up the power cord and the communication line inside the smart zone controller.

f. Close the cover (5)

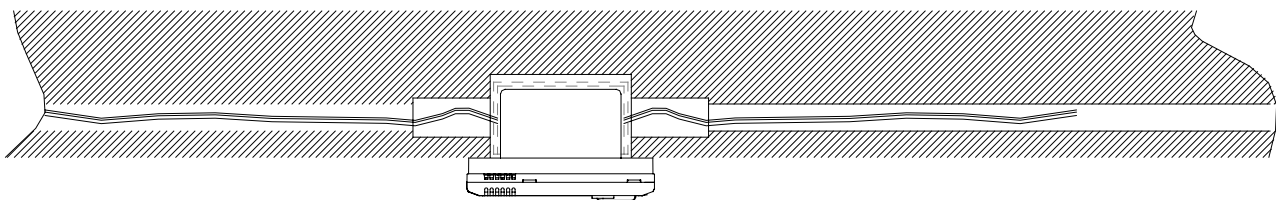

Fig.5.5.4 Concealed Cable Installation 1 (right-left wiring)

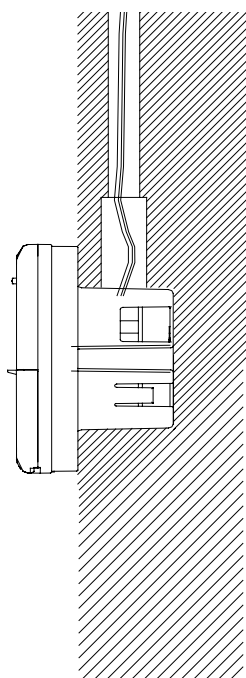

Fig.5.5.5 Concealed Cable Installation 2 (up-down wiring)

Note: the power cord must be separated from the communication line to avoid any interference.

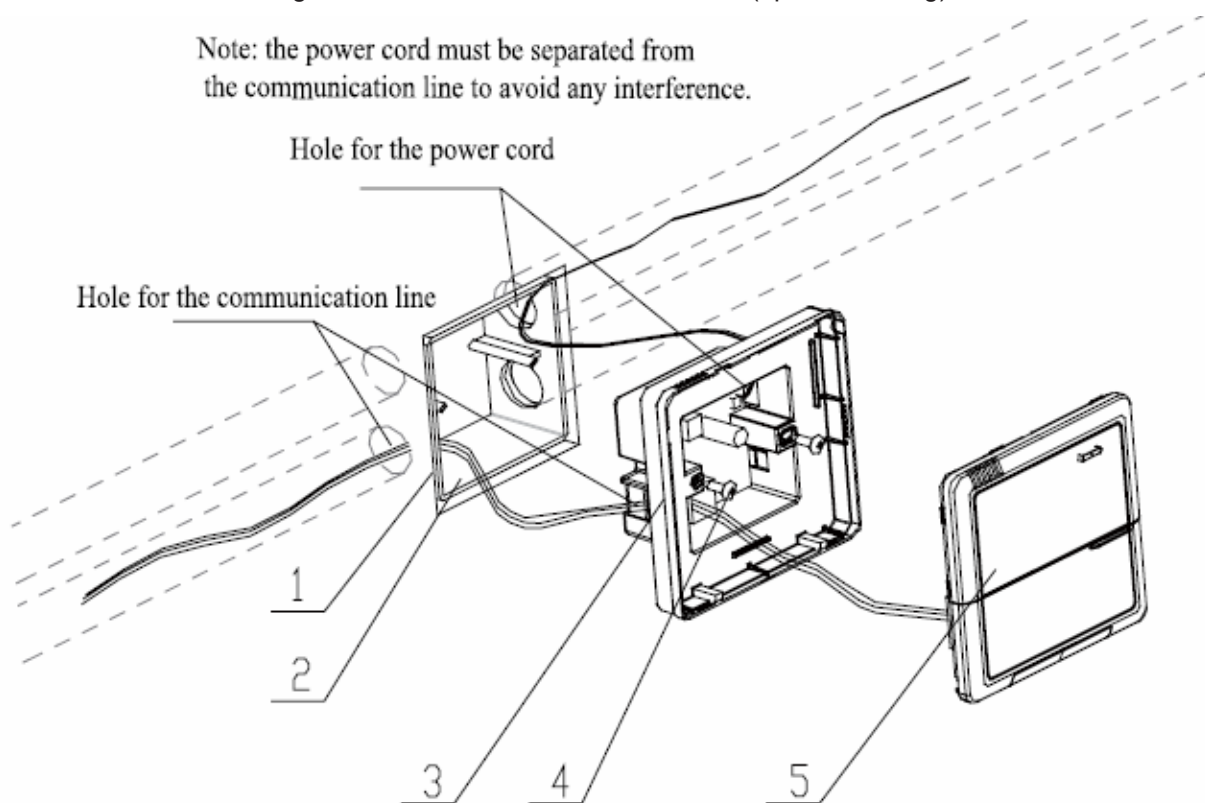

Fig. 5.5.6 Installation Diagram

Serial No.	Description
1	Wall
2	Power Supply Box (86)
3	Bottom Base(including power supply module board)
4	Screw
5	Top Cover(including the display board)

After the installation, it is necessary to make the debugging to guarantee the normal communication.



### 5.5.2 Debugging and Viewing the Port No. and the Indoor Unit Address

**Debugging setting:** In the event that the unit is initially powered on, the setting for the project changes, or the serial port is replaced, and then it is available to go to the debugging status by pressing “Mode” and “Thu” simultaneously for five seconds, under which page, it is enabled to check automatically and distribute the address of the indoor unit. 10 minutes later, the debugging is finished and the indoor unit which gains the address is under control and the unaddressed indoor unit is not.

**Viewing the serial port and the indoor unit address:** It is available to go to the debugging page by pressing “Mode” and “Thu” simultaneously for five seconds, under which page it is enabled to view the serial port and address of the corresponding indoor unit

The press on “Confirm/Cancel” can confirm this debugging setting and go to the viewing state of the current indoor unit; otherwise this setting will not be saved.

See Fig.5.5.7 for the debugging operation. Fig.5.5.7 shows the indoor unit 1 and indoor unit 2, both of which are connected with the port COM2. The address of one is 01 and the other is 04.

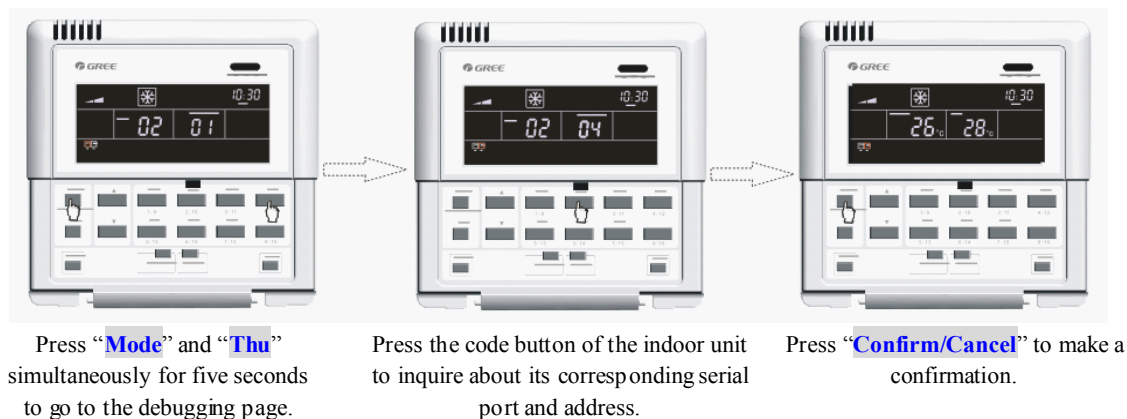

Fig.5.5.7 Debugging

### 5.5.3 Labeling

A label is provided to identify the relationship of the indoor unit No. and the corresponding room name. The user can write down the indoor unit No. and its corresponding room name on the label which then will be stuck to the inside of the cover of the smart zone controller so that the user can be clear about the control object.

For instance, when the user has installed the air conditioners in the child room, bedroom and living room, after the debugging it is available to view the indoor unit No. of each room and get clear about their corresponding relationship.

Room Name	Child Room	Bedroom	Living Room
Indoor Unit Address	Port 1, Indoor Unit 04	Port 1, Indoor Unit 05	Port 1, Indoor Unit 06
Indoor Unit No.	1	2	3

After get clear about the relationship of the indoor unit no. and the room, the user can write “Child Room”, “Bedroom”, “Living Room” on the place “1”, “2” and “3” respectively on the label and then stick the label to the inner side of the smart zone controller.

See 5.5.8 for the label.

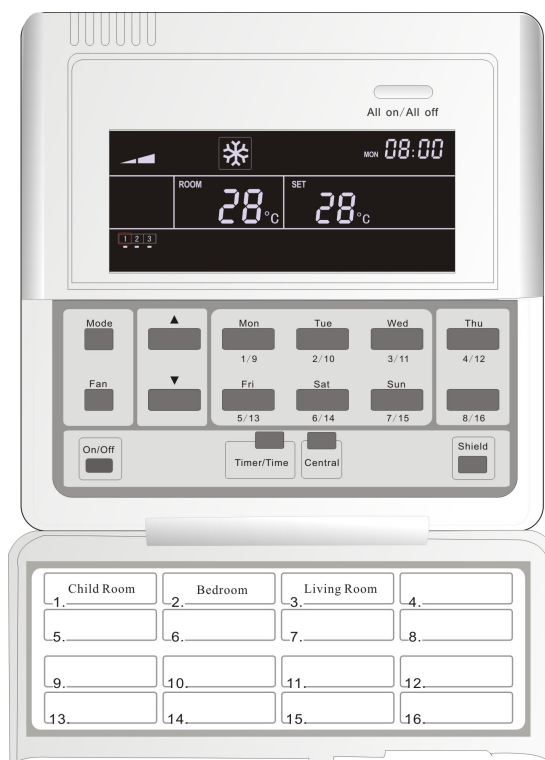

Fig.5.5.8 Label of the Smart Zone Controller

## 5.6 Attachment

Error code list:

### Errors code list of Multi VRF Indoor Units

Code	Description
E1	High pressure protection of the compressor
E2	Anti-freezing protection of the indoor unit
E3	Low pressure protection of the compressor
E4	Discharge temperature protection of the compressor
E5	Over-current protection, overload protection of compressor, drive error
E6	Communication error
E7	Mode conflict
E9	Water overflow protection
EH	E-heater protection
F0	Ambient temperature sensor error of the indoor unit
F1	Error of coil pipe inlet sensor of the indoor unit
F2	Error of coil pipe intermediate sensor of the indoor unit
F3	Error of coil pipe outlet sensor of the indoor unit
F4	Ambient temperature sensor error of the outdoor unit
F5	Error of coil pipe inlet sensor of the outdoor unit
F6	Error of coil pipe intermediate sensor of the outdoor unit
F7	Error of coil pipe outlet sensor of the outdoor unit
F8	Error of discharge temperature sensor 1 (fixed)
F9	Error of discharge temperature sensor 2 (digital)
FA	Error of oil temperature sensor 1 (fixed)
Fb	Error of oil temperature sensor 2 (digital)
Fc	High pressure sensor error
Fd	Low pressure sensor error

## 6 CENTRALIZED CONTROLLER

### 6.1 Central Control ZJ7011

#### 6.1.1 Function

##### Main characteristics of Centralized Controller:

- ◆ A set of Centralized Controller can control 64 communication modules and can connect to as much as 1024 indoor units. It can conduct individual control with any separated area or unified control. It can monitor or control On/Off, Mode, Temperature setting and Timer On/Off of indoor unit etc.
- ◆ It can realize the central, single or select control to all indoor units.
- ◆ It can organize several indoor units into groups as you desired and conduct unified control—Group select control.
- ◆ Error contents are shown by codes. Corresponding communication module numbers of the indoor units with error contents would blink for rapid inspection and repair (There is sound warning for a few errors).
- ◆ Timer function. Every indoor unit can set Timer On/Off time by central, single or select control. Both Timer On time and Timer Off time can be set at the same time, and it is available to set the timer to which day among the 7 days from Sunday to Saturday works.
- ◆ Clock function displays in year, month, day, hour, minute and week, and the clock can be manually adjusted.
- ◆ Indoor and outdoor units online auto detect, display and working state indication.
- ◆ Self-inspection function is remained.
- ◆ Centralized Controller and several communication modules formed communication net, the length of communication wire of the net can be as long as 1km (without using communication repeaters).

**Note: this centralized controller shall be used with communication module ZJ301-W.**

#### 6.1.2 Operation View

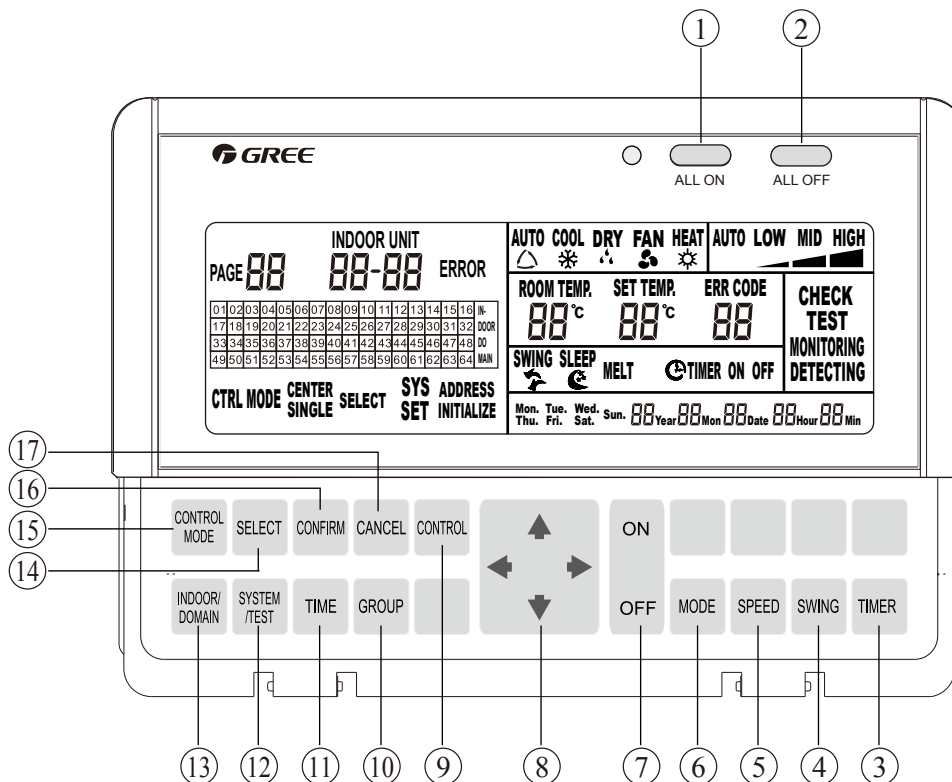

Fig.6.1.2

1	ALL ON	This central control has Sequence On function, that enable conduction to sequence control to communication modular in interval of 2 seconds, communication modular controls Sequence On of indoor units (to lower impact to power network).
2	ALL OFF	This central control has Sequence Off function, that enable conduction of sequence control to communication modular in interval of 2 seconds, communication module controls Sequence Off of indoor units (to lower impact to power network).
3	TIMER	Set and check the time of Timer On and Timer Off of indoor unit and date mode.
4	SWING	Set if indoor unit swings
5	SPEED	Set fan speeds of High, Medium, Low or Auto for indoor unit
6	MODE	Set modes of Cool, Dry, Fan or Heat for indoor unit
7	ON/OFF (2)	For controlling units' on and off.
8	LEFT/RIGHT UP/DOWN	It works as direction and adjusting under every operation function. Such as: When checking, it can move to the required indoor unit or communication modular by using this button; when adjusting time, press LEFT (/RIGHT) to shift "Y/M/D" etc. and press UP (/DOWN) to adjust value
9	CONTROL	Under control mode, press this button after setting state of indoor unit, control to indoor unit would be conducted by corresponding control mode.
10	GROUP	Press button under checking state to begin information check and set of grouped indoor unit, grouped information is for select control.
11	TIME	Set system time
12	SYSTEM/TEST	Begin setting of central control run mode, it is not recommended to be used by users.
13	INDOOR/DOMAIN	Shift display domain and indoor wired air condition control. DOMAIN corresponding to display on line communication modular, INDOOR corresponding to display on line indoor control.
14	SELECT	Select required control or setting object; repress the button to the object is to cancel.
15	CONTROL MODE	Begin control setting mode, and Central Control, Select Control and Single Control can be selected. Central Control: Control all indoor units under domain by present set state. Single Control: Control present indoor unit by present set state. Select Control: Control selected indoor unit by present set state, it also called grouped control
16	CONFIRM	Confirm the operated operation is effective
17	CANCEL	Press this button during process of setting function to exit the already made function setting operation. Such as, if central control mode were selected, press CANCEL at this time would back to control mode selecting state.

6.1.3 Display View

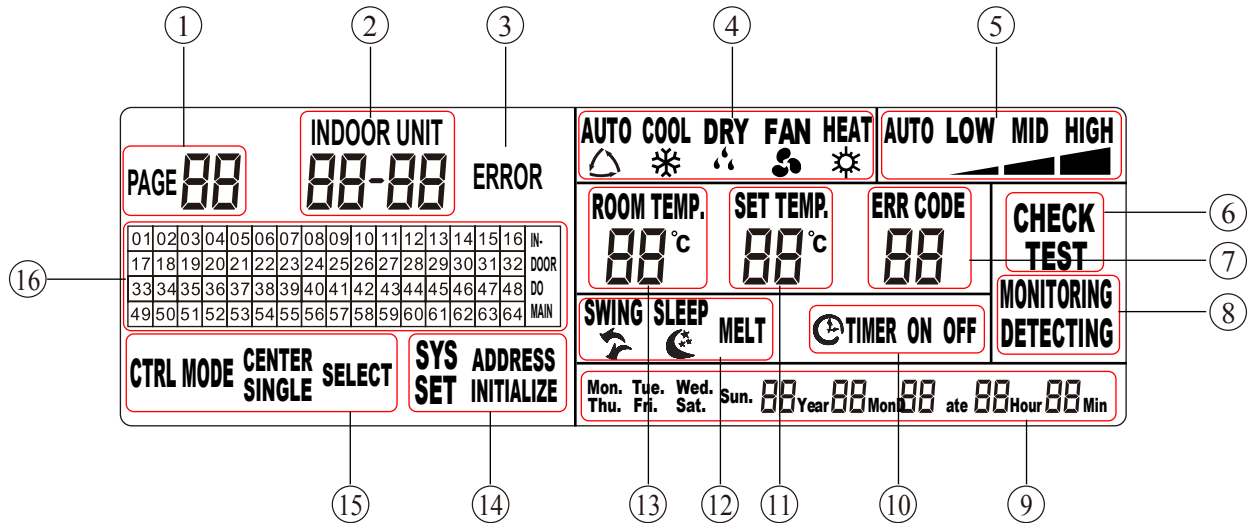

Fig.6.1.3

1	Pagination/displays present domain	Under select control mode, group no. that is present controlling is displayed; Under addresses setting state, present Soft Add is displayed.
2	Present unit no.	Displays the soft address of communication module that the present checking or controlling indoor unit is belonged as well as the address of indoor unit; Format: Soft add—Indoor unit add
3	Error	Displays when there is error at any indoor or outdoor unit.
4	Operation mode	Displays every operation state mode of indoor unit
5	Speed display	Displays High, Medium, Low and Auto speed of indoor unit
6	Check	Under group control mode, it is displayed when checking grouping information; Under address setting mode, it is displayed when checking hard address.
7	Error code	Displays when abnormal occur on operation state of present indoor unit.
8	Operation monitoring and controlling /monitoring	When central control works in normal, operation monitoring displays; when control signal is transmitted, operation monitoring and controlling is displayed.
9	System time	Displays present time, format is Y, M, D, H, M and week.
10	Timer setting	Timer On/Off on when Timer On/Off is set to present indoor unit
11	Pre-set temperature	Displays value of pre-set temperature
12	Swing and Defrost	Displays operation of swing at indoor unit and defrost at outdoor unit
13	Ambient temperature	Displays value of ambient temperature of present indoor unit
14	System setting	Setting operation mode of central control. It should be completed by installation personnel, but not for users.
15	Control mode	Displays 3 control modes of Central, Single and Select controls
16	Displays of soft address	When Indoor on, addresses of present online indoor unit is displayed; When domain on, soft address of present online communication module is displayed; Specific location of controlled indoor unit can only be ascertained When soft address fits Project Installation List.

Instruction to display interface:

**System Setting:** Including Address Setting and other functions, and it is set when installation personnel are adjusting units. It is not recommended that users operate it. The usage of this function requires password.

**Address Setting:** Since characters from 01 to 64 are fixed as the addresses of controlling communication modules displayed by central control (hereinafter called soft addresses), and the addresses of communication modules themselves (hereinafter called hard addresses) are value from 0~254, thus there is address matching problem between central control and controlled communication module. In order to solve this problem, address mapping setting is required to be conducted before project adjusting!

## 6.2 Centralized Controller CE51-24/E(M)

### 6.2.1 Function

Used in multi-VRF system, a set of centralized controller can connect with 64 communication modules to control 1024 sets of indoor units. Through it, indoor unit's ON/OFF, operation mode, set temperature, fan speed, swing state etc. can be queried and controlled. This device can realize single/group/center control and conveniently manage the air conditioners through weekly timer and long-distance shield setting.

- ◆ Single control is to control a single unit;
- ◆ Group control is to control a preset group of indoor units;
- ◆ Center control is to control all indoor units;
- ◆ Single/group/center shield is to shield the operation parameters of indoor units from long distance;
- ◆ Single/group/center weekly timer is to set TIMER ON/OFF of the air conditioner from long distance;
- ◆ Clock setting is to set week, hour and minute and let them show;

The centralized controller can automatically detect the online "region" and indoor unit and display present indoor unit's operation mode, set temperature, fan speed, swing, weekly timer, shield, etc. For the purpose of quick inspection, upon malfunction of any indoor unit, its corresponding error code and region no. will be displayed and blink. The centralized controller integrating multiple communication modules makes up a communication network. Without repeaters, the communication wires' distance can be up to 1km.

**Note: this centralized controller shall be used with communication module ME30-00/E2 or ME30-24/E2(M).**

### 6.2.2 Operation View

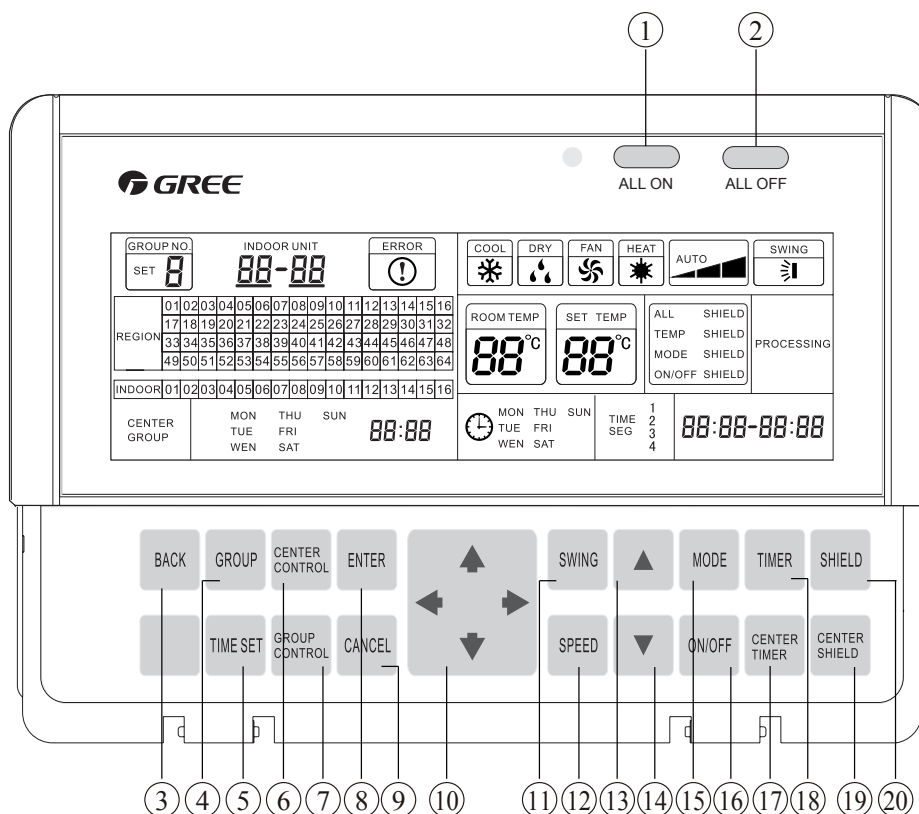



Fig.6.2.2

No.	Description	Function
1	ALL ON	Start up all indoor units
2	ALL OFF	Stop all indoor units
3	BACK	Back to the previous menu of current display.
4	GROUP	Press this button in query state to query and set group information
5	TIME SET	Set system clock
6	CENTER CONTROL	Uniformly control the operation parameters of all indoor units
7	GROUP CONTROL	Uniformly control the operation parameters of one group of indoor units
8	ENTER	Press this button during function setting to confirm the setting
9	CANCEL	Press this button during function setting to cancel the setting. For example, press CANCEL button when CENTER CONTROL has been set, the state will go back to selection of control method.
10	UP/DOWN LEFT/RIGHT 	For direction indication. For example, press these buttons in query state to select the indoor unit or communication modules to be queried.
11	SWING	Set swing or not
12	SPEED	Set high,medium,low or auto fan speed
13	▲ Increase	Increase set temperature
14	▼ Decrease	Decrease set temperature
15	MODE	Set COOL,DRY,FAN or HEAT mode
16	ON/OFF	Set unit on or off
17	CENTER TIMER	Centrally set or query timer
18	TIMER	Set or query timer
19	CENTER SHIELD	Centrally shield functions of all indoor units
20	SHIELD	Shield functions of a single or a group of indoor unit/s

6.2.3 Display View

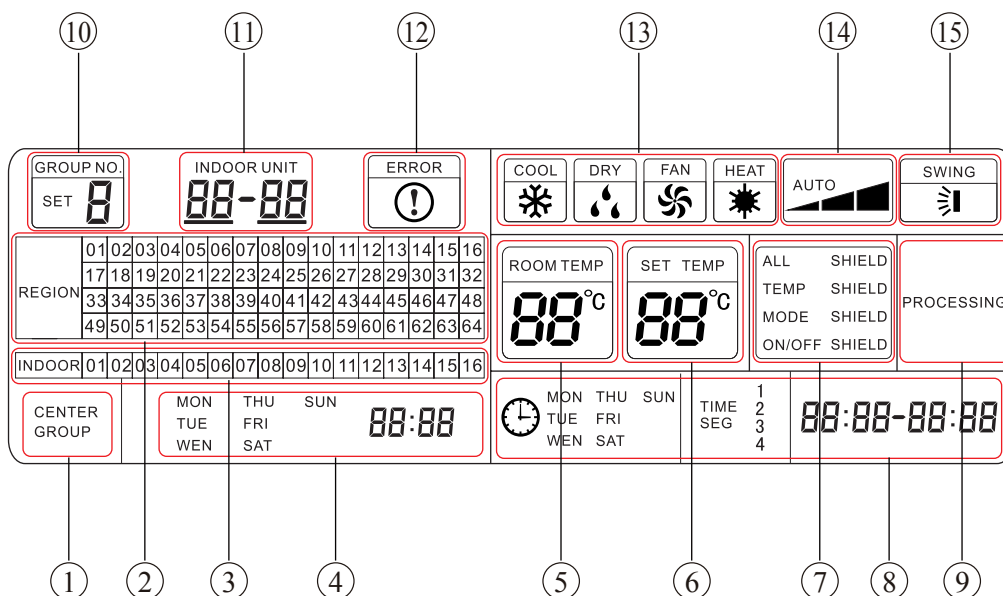

Fig.6.2.3

No.	Description	Instruction to Displaying Contents
1	CENTER/GROUP	"GROUP" displayed during group control operation or grouping indoor units "CENTER" displayed during center control ,center shield or center timer operation.
2	REGION NO.	Online or selected region No. displayed(Note 1)
3	INDOOR UNIT NO.	Online or slected indoor unit no. displayed
4	System's time display	Display present time by week, hour and minutes
5	ROOM TEMP	Room temperature of present indoor unit
6	SET TEMP	Set temperature display
7	SHIELD	All/temperature/mode/on/off shield from long distane
8	Timer setting display	Weekly timer display
9	PROCESSING	Displayed during sending out control command
10	GROUP NO.	Group No. display
11	INDOOR UNIT	Display region No.and unit no. of present indoor unit
12	ERROR	Error display upon malfunction of any unit
13	Opearation mode	Operation mode display of indoor unit
14	Fan speed display	High, medium, low or auto fan speed display
15	SWING	Swing operation mode display of indoor unit



### 6.2.4 Installation

After selection of installation location, perform the installation as follow:

1) Confirm installation hole site:

To be installed in the wall

(1) Drill a hole of of 180mm×106mm×72mm (L×W×D)

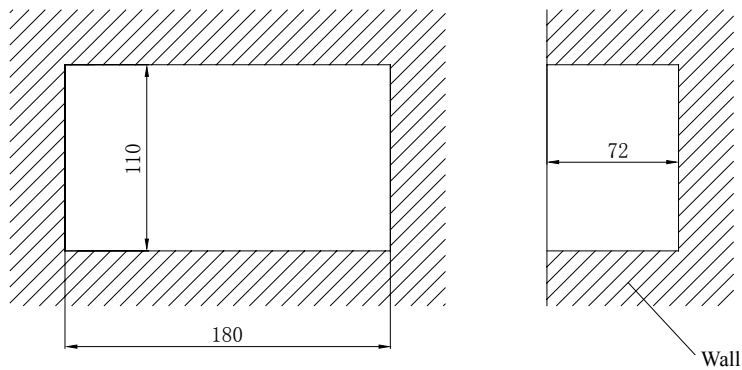

Fig.6.2.4.1

(2) Make 4 pieces of wooden or plastic chucks

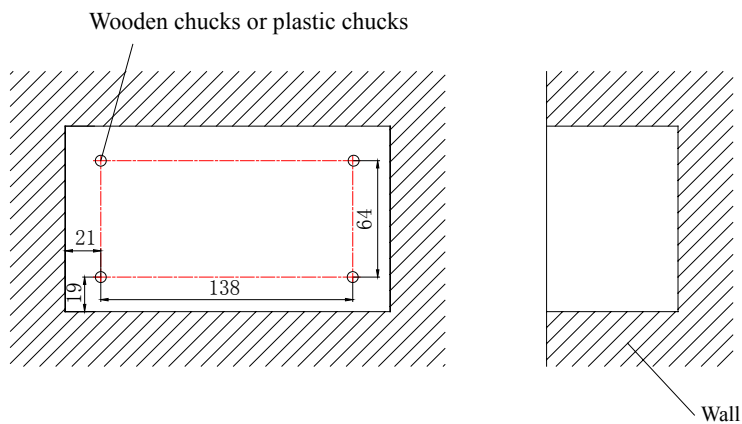

Fig.6.2.4.2

To be installed in the control cabinet:

Make 4 holes inside the wall of control cabinet according to the following dimension in the figure.

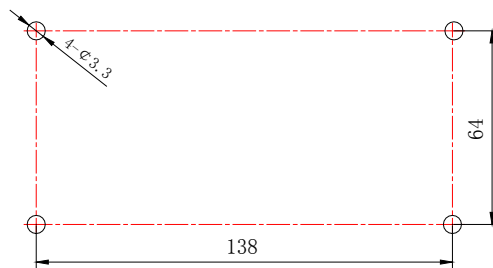

Fig.6.2.4.3

2) Install the electric box cover on the wall or in the control cabinet.

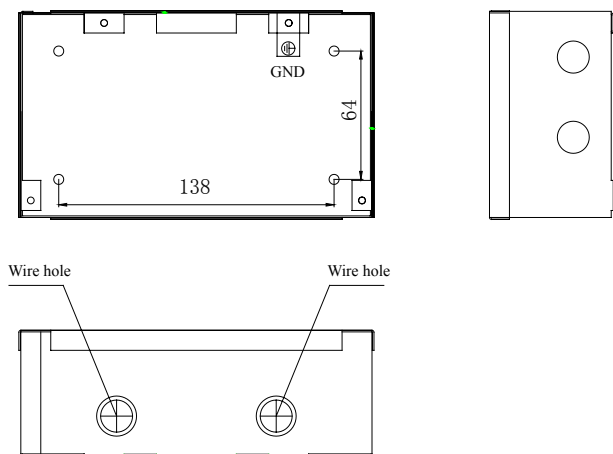

Fig.6.2.4.4

3) Connection of power cord and communication wire

Make the communication wire through the wire hole of the electric box cover and insert it into the communication port. Make the Power cord through the other wire hole on the electric box cover should be connected with the wiring terminal on the mainboard of controller ,as shown in the figure below. L connects with live wire, N connects with neutral wire and ground wire connects to the corresponding position marked on the electric box. Wire hole can be freely set according to actual condition.

Power cord width connected with wiring terminals shall be in the range of 1.5~2.2mm.

Rated voltage of wiring terminal is 220~240 VAC.

Power frequency is 50/60HZ.

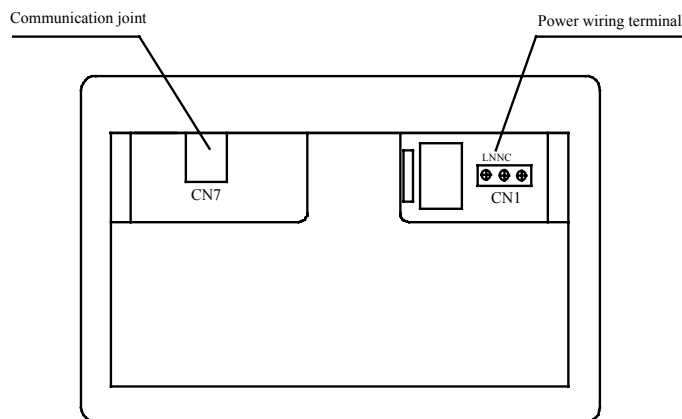

Fig.6.2.4.5

4) Divide the centralized controller into two parts from the buckle as shown in the following figure-----  
upper cabinet and lower cabinet

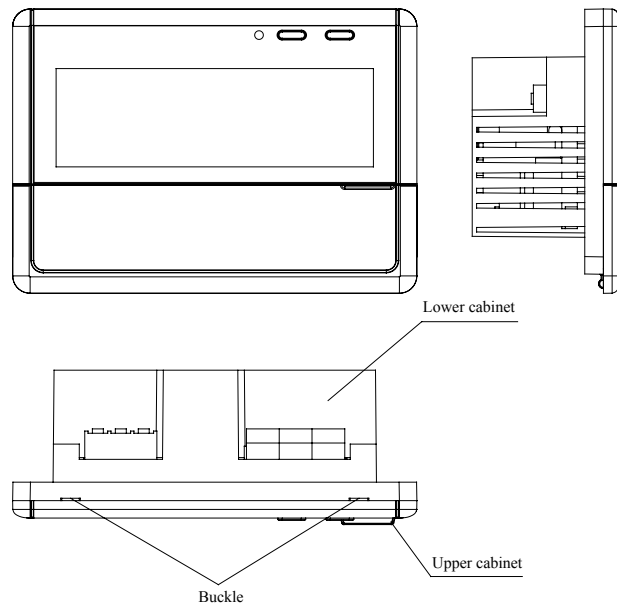

Fig.6.2.4.6

5) Connect the electric box cover and lower cabinet with screws according to the following figure.

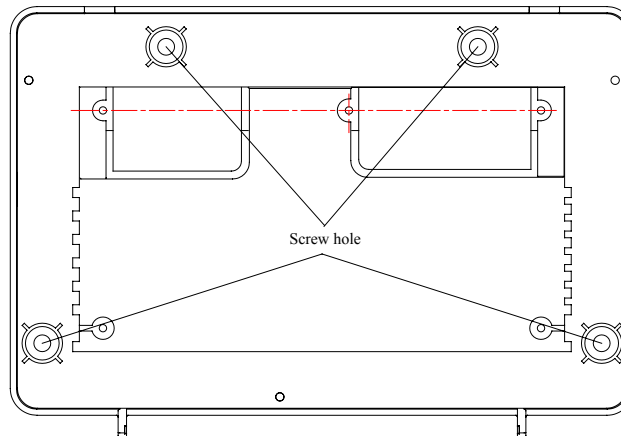

Fig.6.2.4.7

6) Re-assemble the upper cabinet and debugging can begin after this.

## 6.2.5 Connection Between Controller and Unit

### Communication network

The following is a brief sketch of communication net of multi variable units:

## 6.2.6 Connection between centralized controller and communication module

Connection of them is shown in figure 6.2.6.1

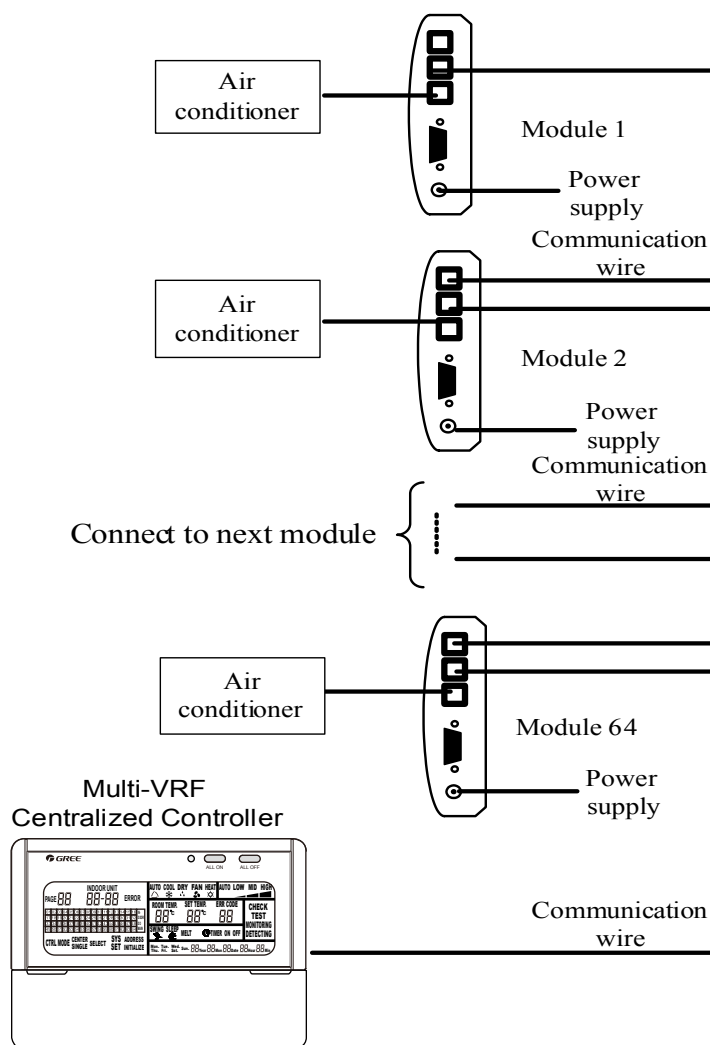

Fig.6.2.6.1 Sketch map of connection between centralized controller and communication module

**Note:**

- ①. Communication module's address can be set from 1 to 64. In order to avoid communication malfunction, addresses can not be the same.
- ②. The communication wire of communication modules or centralized controller shall be equipped according to the distance in the project.
- ③. Gree provides a piece of 2-core communication wire of 1m (the user shall extend the wire according to actual condition).
- ④. The centralized controller and the communication module are connected together through a communication line with a crystal connector at both ends. Close to the controller, a magnetic ring is needed on the communication line and is approximately 10cm away from the crystal connector after wrapped two circles by the communication line. During the installation, the magnetic ring should be put inside the electric control box after the crystal connector is connected with the smart zone controller. See the following figure for the connection manner and location.



Fig.6.2.6.2 Connection Manner of Crystal Connector, Communication Line and Magnetic Ring



Fig.6.2.6.3 Connection Location of Crystal Connector, Communication Line and Magnetic Ring

After completion of installing centralized controller and matched communication modules, the technician shall set address and perform debugging of the communication modules to ensure normal communication.

### 6.2.7 Debugging

In order to ensure normal operation of the centralized controller, the address of communication module shall be set after installation work. (Refer to Communication Module Instruction for details.) Fill in the Installation Table (refer to table 3)

#### 6.2.7.1 Address setting of communication module

Set the address of communication module by the DIP switch. (Before operating DIP switch, cut off the power supply of communication module.)

The DIP switch for communication module:



Fig.6.2.7.1 DIP switch

#### 1) DIP2 setting

Dial all the rods to ON (means 0), as shown in Fig.6.2.7.2

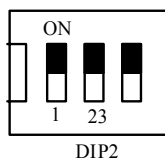

Code list from 1 to 7			
1	2	3	Value
0	0	0	0
1	0	0	1
0	1	0	2
1	1	0	3
0	0	1	4
1	0	1	5
0	1	1	6
1	1	1	7

Fig.6.2.7.2 DIP2 setting

2) DIP1 setting

The 8-bit DIP switch in the communication module is for Modbus equipment address setting. It is integrated by SA2 and SA3 on PCB, but marked by DIP1. Dialing to ON means 0, and dialing to number end means 1. The address setting range is 1-64 (communication module address).

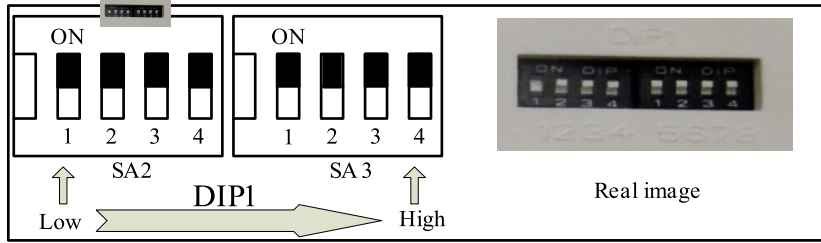

Fig. 6.2.6.3 DIP1 setting

(1) Graphic example for setting of address 11

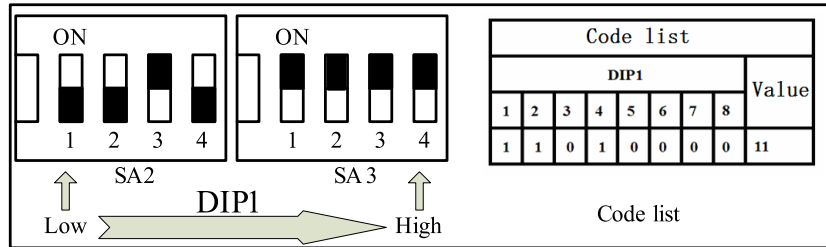

Fig. 6.2.6.4 Address 11

(2) Graphic example for setting of address 43

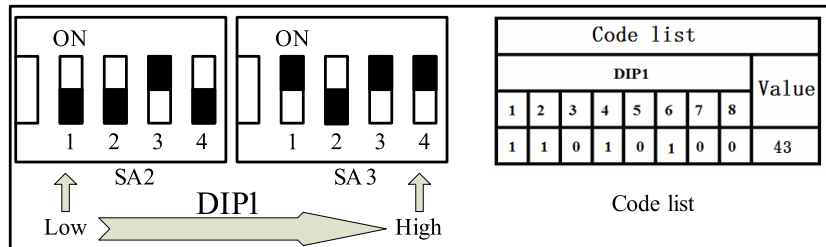

Fig. 6.2.7.5 Address 43

6.2.7.2 Debugging

After address setting of communication module, check if the setting is correct through the region no. on the centralized controller. For example, the address is set to "01", the centralized shall display region no. "01". If the region no. "01" is not displayed, it proves that the setting is incorrect. You should reset the address no. according to the Communication Module Instruction and DIP table.

After normal communication between centralized controller and communication module, an Installation Table shall be filled for check of information about each indoor unit. If the quantity of indoor units by check is inconsistent with that of the installed indoor units, address setting the communication module and connection of the communication wire shall be checked again.

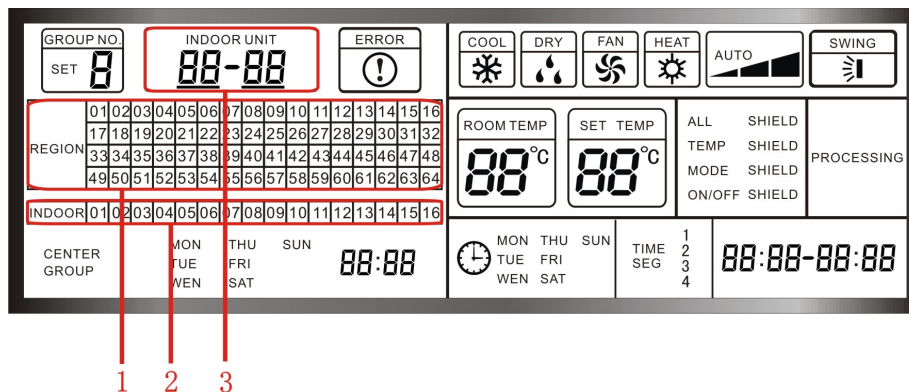

Fig. 6.2.7.6

Installation Table

Table 3 Installation Table

Region No.	Indoor unit no.	Present indoor unit no.	Indoor unit location
08	03	08-03	No.3 indoor unit in Room B Floor A

**Note:**

- ①. Region no. indicates online region no.1-64, displayed by the centralized controller.
- ②. Indoor unit no. indicates online indoor unit no., 1-16, displayed by centralized controller.
- ③. Present indoor unit no. indicates present indoor unit no. displayed by centralized controller.
- ④. Indoor unit location indicates actual location of centralized controller, which is expressed by No.\_\_\_\_ indoor unit, Room\_\_\_\_, Floor \_\_\_\_\_.

6.2.8 Attachment

Error Code List:

Error code list of GMV VRF

Error Code	Malfunction
E1	High pressure protection of compressor
E2	Antifreezing protection of indoor unit
E3	Low pressure protection of compressor
E4	Discharge temperature protection of compressor
E5	Overcurrent protection, overload protection of compressor, drive malfunction
E6	Communication malfunction
E7	Modes conflict
E8	Indoor fan motor protection
E9	Water overflow protection (cassette type unit)
EH	E-heater protection
F0	Ambient temperature sensor malfunction of indoor unit
F1	Malfunction of coil pipe inlet sensor of indoor unit
F2	Malfunction of coil pipe intermediate sensor of indoor unit
F3	Malfunction of coil pipe outlet sensor of indoor unit
F4	Ambient temperature sensor malfunction of outdoor unit
F5	Malfunction of coil pipe inlet sensor of outdoor unit
F6	Malfunction of coil pipe intermediate sensor of outdoor unit
F7	Malfunction of coil pipe outlet sensor of outdoor unit
F8	Malfunction of discharge temperature sensor 1(fixed)
F9	Malfunction of discharge temperature sensor 2 (digital)
FA	Malfunction of oil temperature sensor 1(fixed)
Fb	Malfunction of oil temperature sensor 2 (digital)
Fc	High pressure sensor malfunction
Fd	Low pressure sensor malfunction
H6	PG Motor Stalling Protection

DIP table of communication module

DIP table of communication module

DIP1								Address value	DIP1								Address value
1	2	3	4	5	6	7	8		1	2	3	4	5	6	7	8	
1	0	0	0	0	0	0	0	1	1	0	0	0	0	1	0	0	33
0	1	0	0	0	0	0	0	2	0	1	0	0	0	1	0	0	34
1	1	0	0	0	0	0	0	3	1	1	0	0	0	1	0	0	35
0	0	1	0	0	0	0	0	4	0	0	1	0	0	1	0	0	36
1	0	1	0	0	0	0	0	5	1	0	1	0	0	1	0	0	37
0	1	1	0	0	0	0	0	6	0	1	1	0	0	1	0	0	38
1	1	1	0	0	0	0	0	7	1	1	1	0	0	1	0	0	39
0	0	0	1	0	0	0	0	8	0	0	0	1	0	1	0	0	40
1	0	0	1	0	0	0	0	9	1	0	0	1	0	1	0	0	41
0	1	0	1	0	0	0	0	10	0	1	0	1	0	1	0	0	42
1	1	0	1	0	0	0	0	11	1	1	0	1	0	1	0	0	43
0	0	1	1	0	0	0	0	12	0	0	1	1	0	1	0	0	44
1	0	1	1	0	0	0	0	13	1	0	1	1	0	1	0	0	45
0	1	1	1	0	0	0	0	14	0	1	1	1	0	1	0	0	46
1	1	1	1	0	0	0	0	15	1	1	1	1	0	1	0	0	47
0	0	0	0	1	0	0	0	16	0	0	0	0	1	1	0	0	48
1	0	0	0	1	0	0	0	17	1	0	0	0	1	1	0	0	49
0	1	0	0	1	0	0	0	18	0	1	0	0	1	1	0	0	50
1	1	0	0	1	0	0	0	19	1	1	0	0	1	1	0	0	51
0	0	1	0	1	0	0	0	20	0	0	1	0	1	1	0	0	52
1	0	1	0	1	0	0	0	21	1	0	1	0	1	1	0	0	53
0	1	1	0	1	0	0	0	22	0	1	1	0	1	1	0	0	54
1	1	1	0	1	0	0	0	23	1	1	1	0	1	1	0	0	55
0	0	0	1	1	0	0	0	24	0	0	0	1	1	1	0	0	56
1	0	0	1	1	0	0	0	25	1	0	0	1	1	1	0	0	57
0	1	0	1	1	0	0	0	26	0	1	0	1	1	1	0	0	58
1	1	0	1	1	0	0	0	27	1	1	0	1	1	1	0	0	59
0	0	1	1	1	0	0	0	28	0	0	1	1	1	1	0	0	60
1	0	1	1	1	0	0	0	29	1	0	1	1	1	1	0	0	61
0	1	1	1	1	0	0	0	30	0	1	1	1	1	1	0	0	62
1	1	1	1	1	0	0	0	31	1	1	1	1	1	1	0	0	63
0	0	0	0	0	1	0	0	32	0	0	0	0	0	0	1	0	64



### 6.3 Connection Between Controller and Unit

#### Communication network

The following is a brief sketch of communication net of multi variable units:

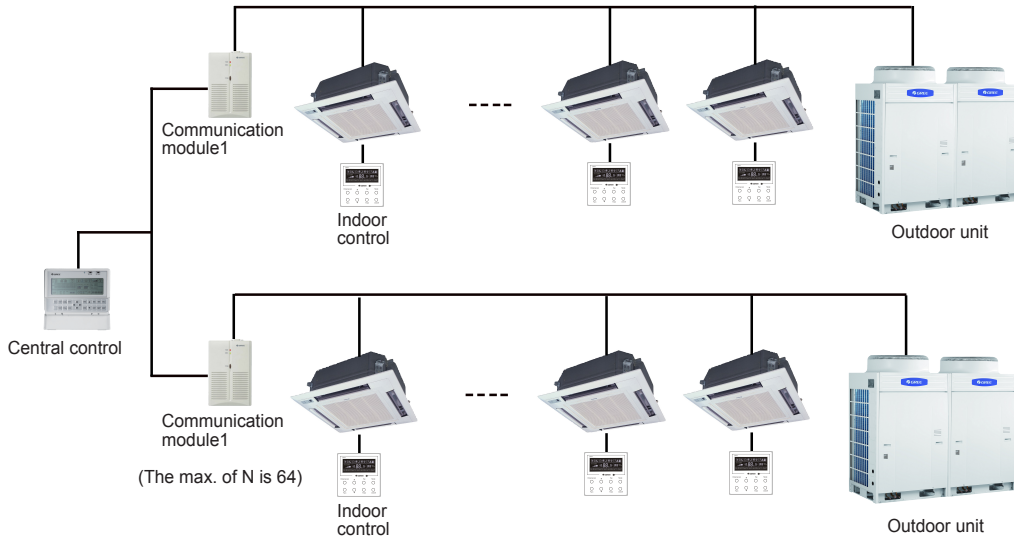

Fig.6.1.4

As shown in figure, the "v" at A are parting lines for communication net. Left side of the "v" is the communication net between central control and communication module while the right side is that between multi variable outdoor unit and indoor units. The 2 nets are individual nets.

Before normal use of central control, do conduct addresses setting and adjusting to communication system by installation personnel. Only after that can the central control offered to be used by user.

### 6.4 Case Study

Take one floor of an office building for example to illustrate wiring and debugging of the centralized control system. In this floor, there are 2 assembly rooms, 8 offices and 1 monitor room. Refer to the following illustration for its plane structure.

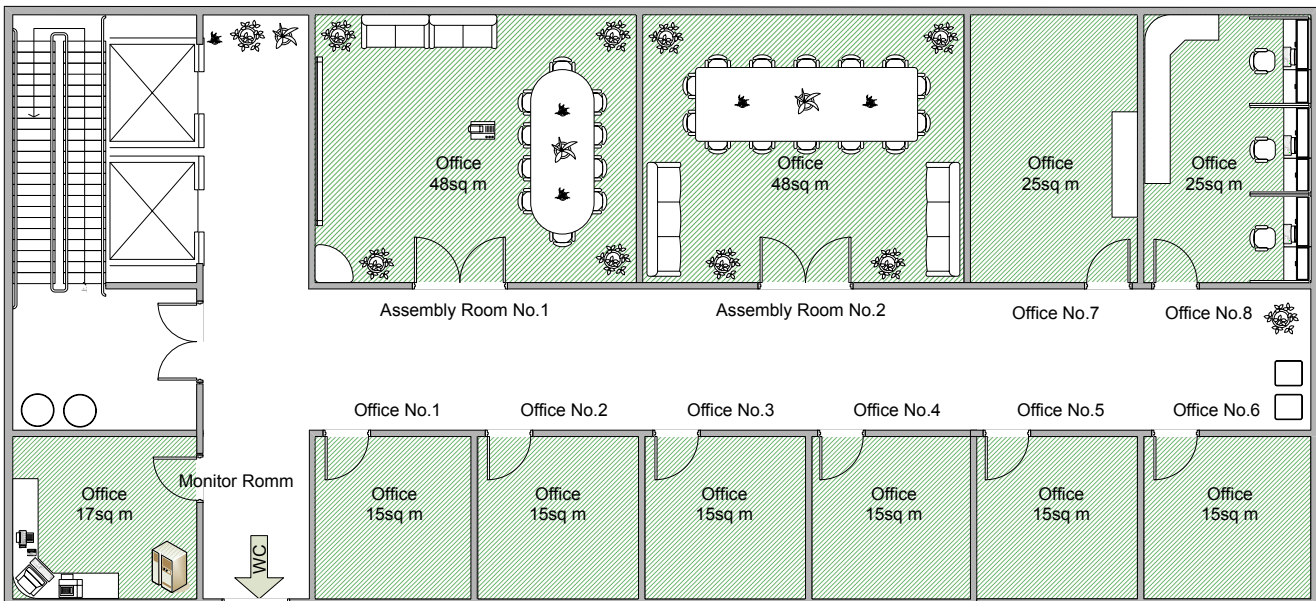

Fig.6.5

### 6.4.1 Instruction to Distribution of Unit and Installation of Equipment

This office building has been installed with 2 sets of GMV units, as shown in the table below.

Name	Models	Quantity of required communication modules (pinboard)	Quantity of indoor units	Corresponding rooms of indoor units		
				Room	Address of communication module	Address of indoor unit
Unit1	GMV-Pdm450W/ NaB-M	1(0)	12	Room	01	
				Office 1		1,2
				Office 2		3,4
				Office 3		5,6
				Office 4		7,8
				Office 5		9,10
	Office 6	11,12				
Unit 2	GMV-Pdm280W/ NaB-M	2(2)	20	Room	02	
				Office 7		1,2
				Office 8	3,4	
				Assembly room 1	03	1,2,3,4
				Assembly room 2		5,6,7,8,9

6.4.2 Frame Diagram of System Net

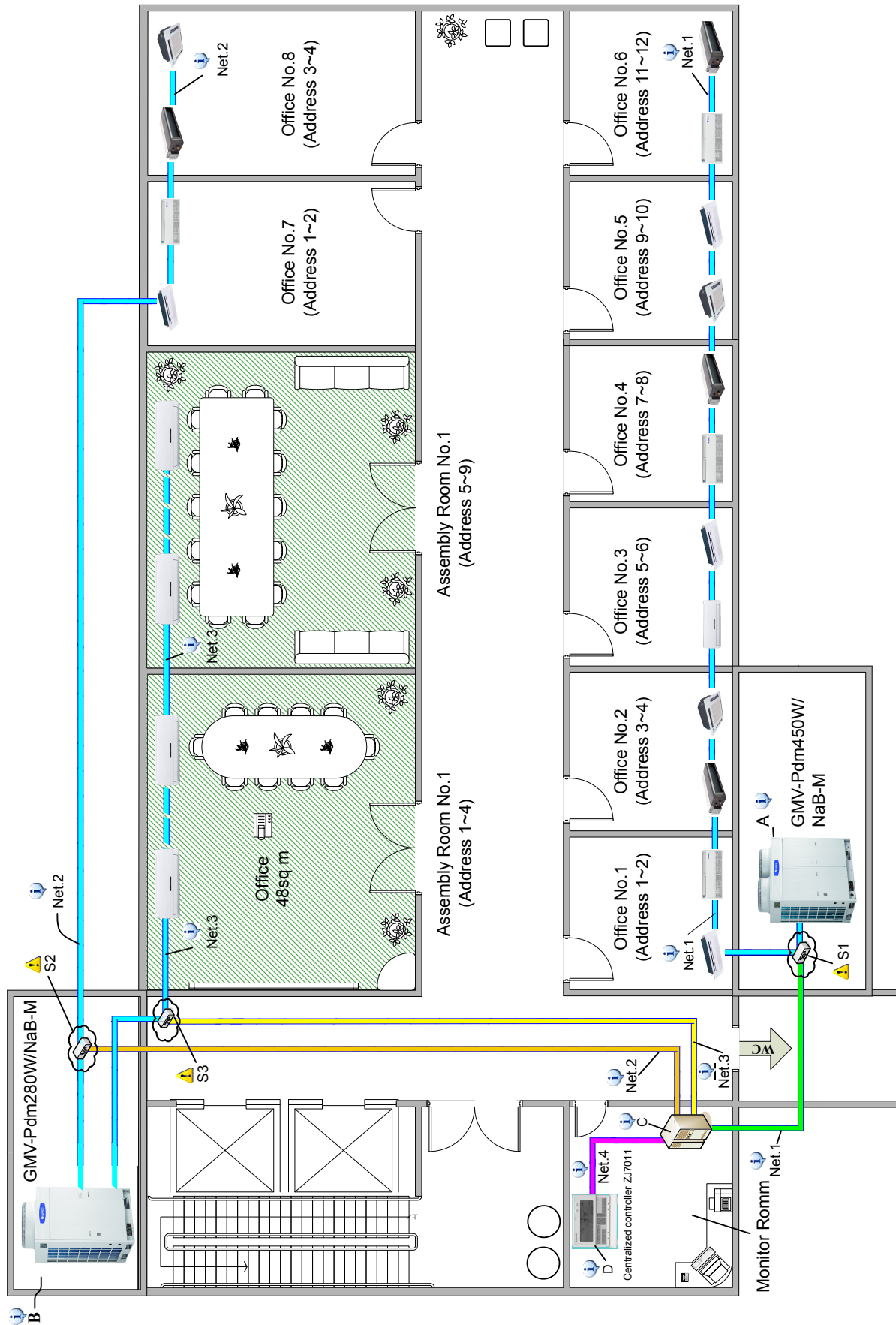

Instruction to Frame Diagram of System Net

**Mark A:**

Outdoor Unit GMV-Pdm450W/NaB-M can be connected with up to 32 indoor units by two pinboards, either of which can connect with up to 16 indoor units. What's more, the quantity of communication modules used is the same as that of pinboards.

In this project, pinboard 1 is connected with the communication module with address of 02 and indoor units (address 01~04) of office 7-8, corresponding with independent communication Net.2. Pinboard 2 is connected with communication module of address 03 and indoor units (address 01~08) of office 1-2, corresponding with independent communication Net.3. The outdoor figure is as follow:

**Mark B:**

Outdoor Unit GMV- Pdm 280W/NaB-M can be connected with up to 32 indoor units by two pinboards, either of which can connect with up to 16 indoor units. What's more, the quantity of communication modules used is the same as that of pinboards.

In this project, pinboard 1 is connected with the communication module with address of 02 and indoor units (address 01~04) of office 7-8, corresponding with independent communication Net.2. Pinboard 2 is connected with communication module of address 03 and indoor units (address 01~08) of office 1-2, corresponding with independent communication Net.3. The outdoor figure is as follow:

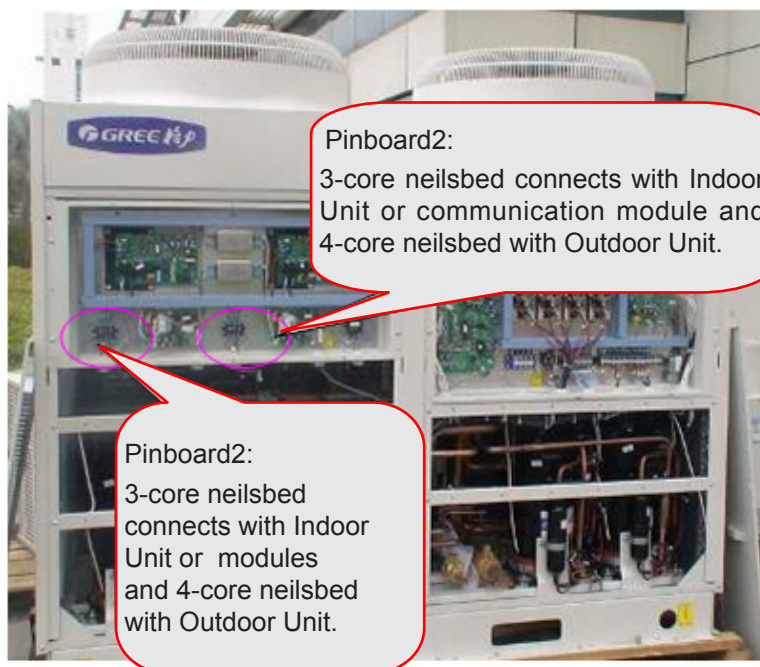
**Mark C:**

Centralized controller cabinet is mainly used to put communication modules together. Refer to Section 3 Instruction to Installation Procedure of System about its figure and connection method of communication modules.

**Mark D:**

Centralized Controller ZJ701. For the first use of it, address mapping setting must be made to specify addresses of communication modules which should be controlled. In this project example there are 3 communication modules with the address of 01, 02 and 03 which are displayed in the centralized controller correspondingly.

**Mark S1, S2, and S3:**

Telephone 3-way triple adapters are used to connect communication modules with communicating net of indoor and outdoor units. Refer to Section 3 Instruction to Installation Procedure of System for its connection method.

### 6.4.3 Instruction to Installation Procedure of System

#### Step 1: Integral Design of the Whole System.

In consideration of features of building and installation of the unit, the building is divided into a lot of monitoring regions and then confirm required systems, their quantity and installation locations. As for this example:

A. Division of monitoring regions: According to needs of the users, the whole floor is divided into 3 monitoring regions, south area (office 1-6), north area (assembly room1-2 and office 7-8) and monitor room.

B. Confirmation of quantity of systems

Name	Qty	Installation Location	Notes
Communication modules	3	Centralized control cabinet	The quantity required for the pinboards is the same as communication modules. If no pinboard, only one module is needed. So, there should be 3 modules in total.
Centralized control cabinet	1	Monitor room	Installed indoors according to user's conditions.
Centralized controller	1	Monitor room	Installed indoors

#### Step 2: Wiring and Installation

A. Centralized controller as extension function of GMV unit can be installed and debugged after communication connection between outdoor unit and indoor unit and normal operation of the unit.

B. Make of centralized control cabinet

If a lot of communication modules are used, centralized control cabinet is recommended. Heavy current wires and communication lines should be wired separately. The distance between them should keep above 15cm. The following figure is an example of centralized control cabinet, but its design should be according to quantity of communication modules.



C. Connection of communication modules

COM 1 of communication module can connect with indoor and outdoor unit. The two COM2 can connect with other communication module or centralized controller. As shown in the following figure:

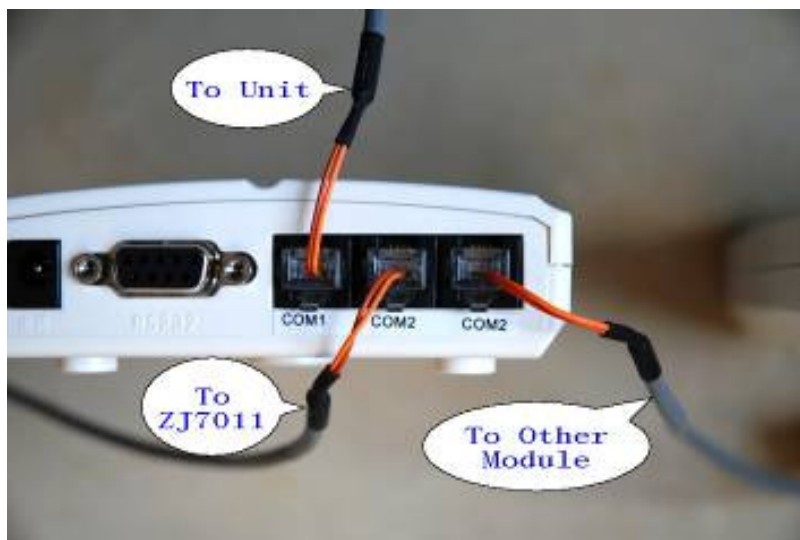

D. Connection between communication module and indoor and outdoor units

According to the net diagram, connect the communication line between indoor unit and outdoor unit. Then cut off the communication line between the mainboards of indoor unit and outdoor unit, as shown below.

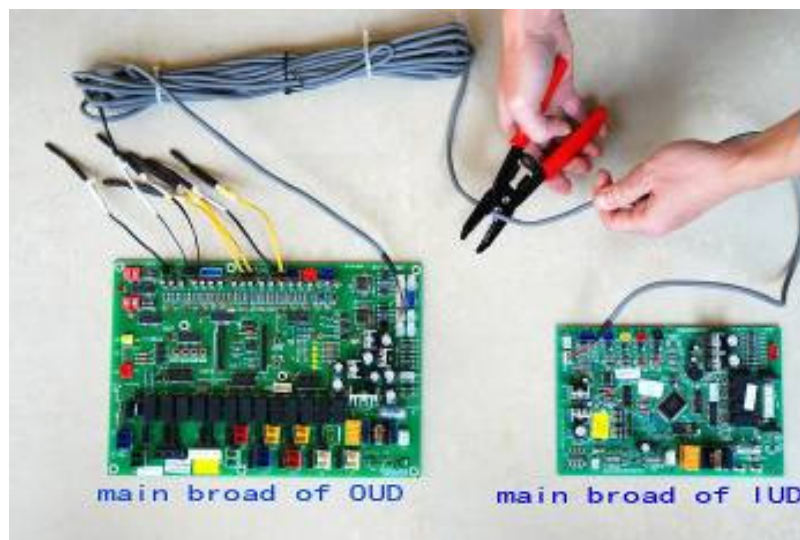

Align the cutting terminals and terminals of communication line to COM1, as shown below:

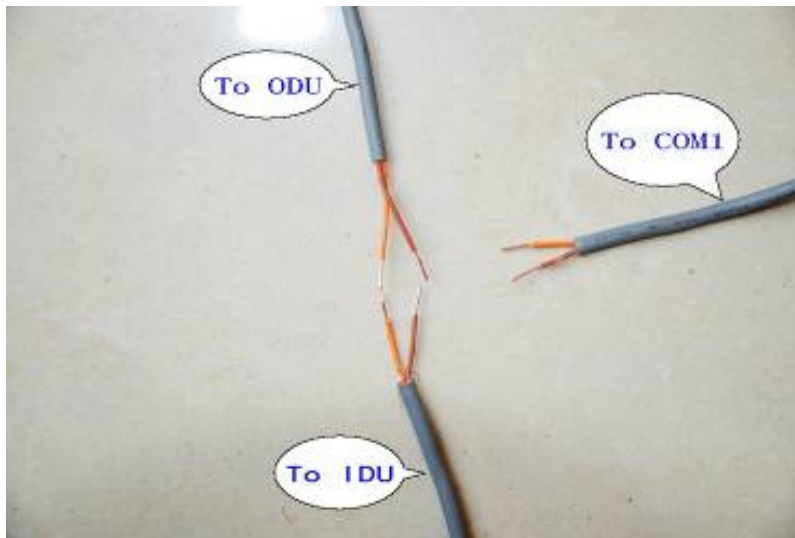

In this case, there are two methods to connection of them.

**Method 1: Welding**

Weld the two cutting terminals by yellow to yellow and brown to brown, as shown below:



And then weld the terminals of communication line to COM1 with the welding spots in the above figure together by yellow wire to brown wire, as shown below:

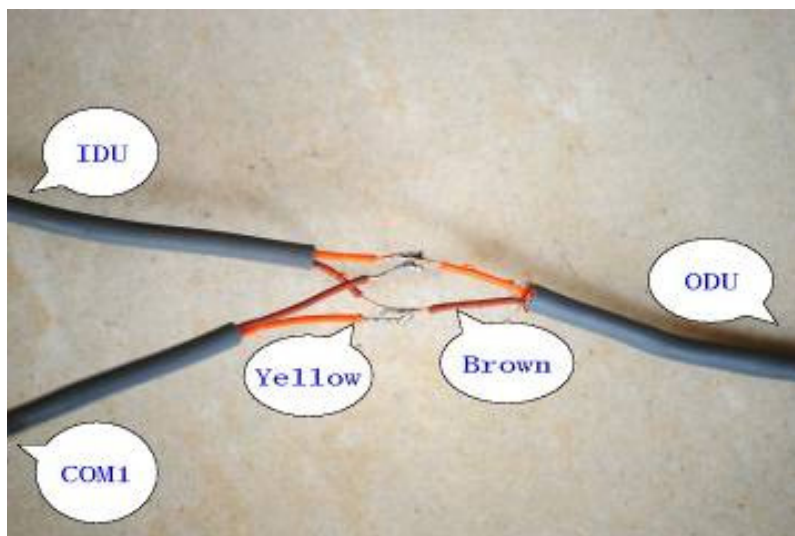

At last, wrap the welding spots with insulating tape and test conduction performance of the three communication lines, as shown below:



### Method 2: Triple adapter

Make crystal heads for the three lines. The connection direction should be the same as in the above welding figures, i.e. yellow to yellow and brown to brown wire of indoor and outdoor units, but yellow to brown wire of communication line to COM1. The crystal heads are as follow:

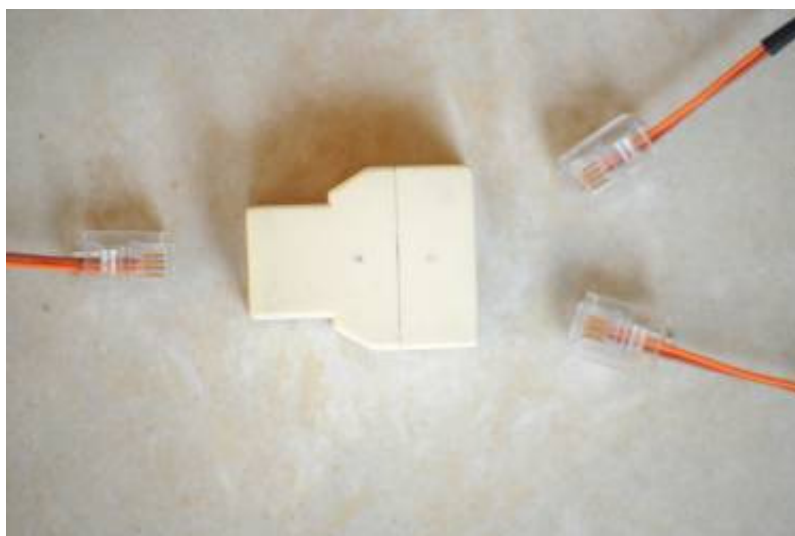

Insert the three crystal heads into the triple adapter and test conduction performance of them, as shown below:

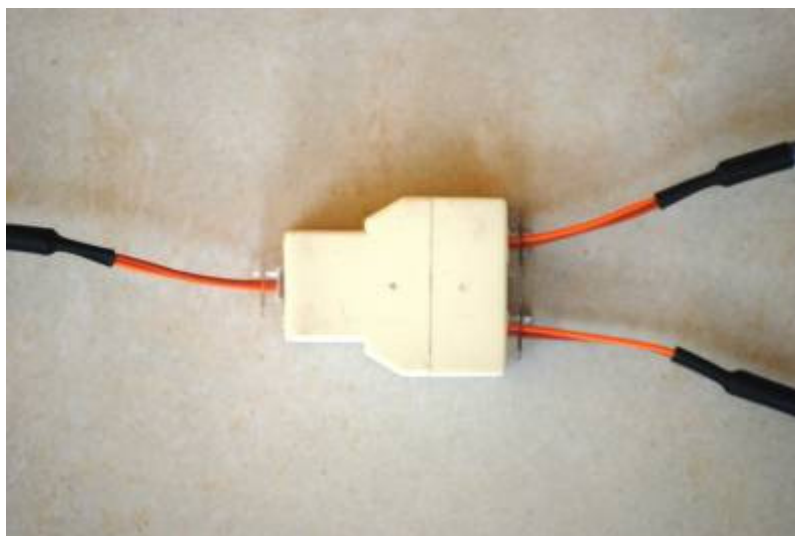



### E. Connection of Communication Modules and Centralized Controller

Connection of COM1 of communication module which has 3 COM in total has been introduced as the above. COM2 can connect with another communication module or centralized controller, as shown below:

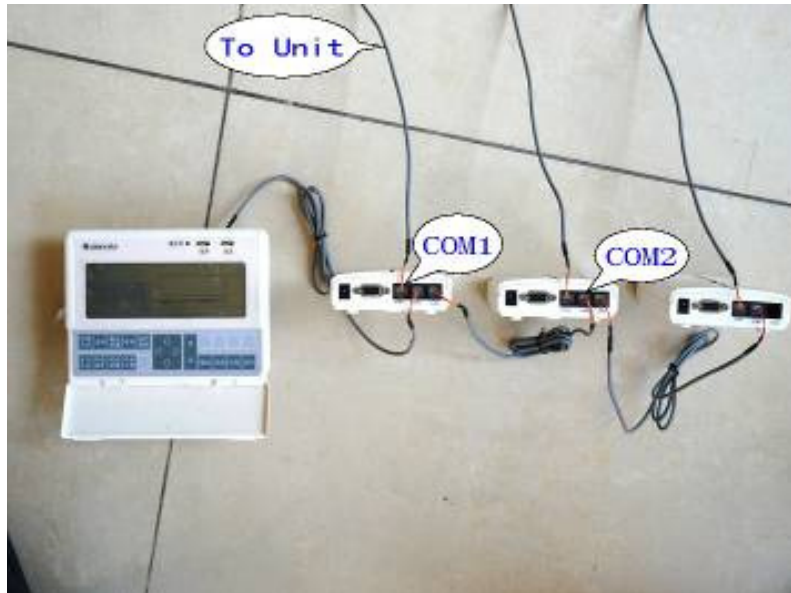

**Step 3: There are two methods of DIP address setting of communication module.**

#### Method 1:

The address of each communication module has been fixed in the factory and marked on the label at the back of it. It is unnecessary for users to set anything. In addition, the 3-digital DIP can not be dialed to OFF completely, as shown below:

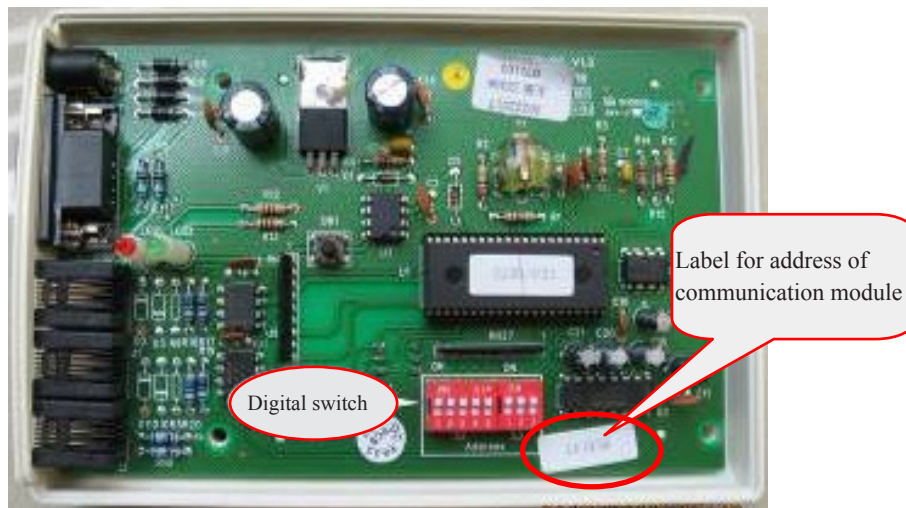

**Method 2:**

Manual setting of address, as operated the following:

1) Dial the digital switch at the back of communication module to OFF completely, as below:

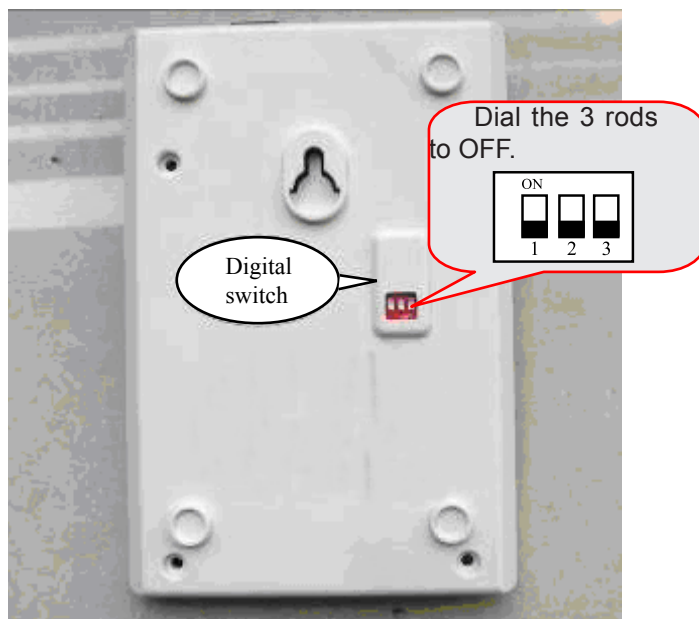

2) Open the cover of communication module as below:



The 8-digital DIP is as below:

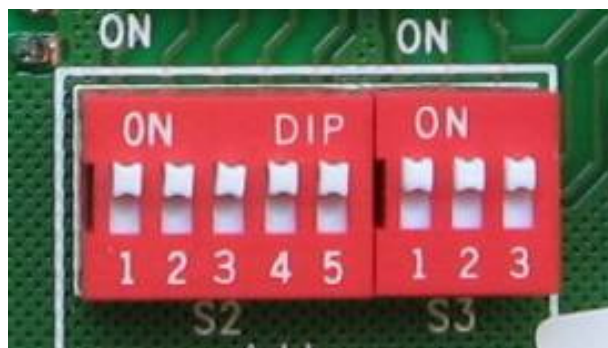

Set DIP for address according to the following table.

Address from 0 to 31								Address	Address from 32 to 63									Address
DIP S2					DIP S3				DIP S2					DIP S3				
1	2	3	4	5	1	2	3		1	2	3	4	5	1	2	3		
0	0	0	0	0	0	0	0	0	0	0	0	0	0	1	0	0	32	
1	0	0	0	0	0	0	0	1	1	0	0	0	0	1	0	0	33	
0	1	0	0	0	0	0	0	2	0	1	0	0	0	1	0	0	34	
1	1	0	0	0	0	0	0	3	1	1	0	0	0	1	0	0	35	
0	0	1	0	0	0	0	0	4	0	0	1	0	0	1	0	0	36	
1	0	1	0	0	0	0	0	5	1	0	1	0	0	1	0	0	37	
0	1	1	0	0	0	0	0	6	0	1	1	0	0	1	0	0	38	
1	1	1	0	0	0	0	0	7	1	1	1	0	0	1	0	0	39	
0	0	0	1	0	0	0	0	8	0	0	0	1	0	1	0	0	40	
1	0	0	1	0	0	0	0	9	1	0	0	1	0	1	0	0	41	
0	1	0	1	0	0	0	0	10	0	1	0	1	0	1	0	0	42	
1	1	0	1	0	0	0	0	11	1	1	0	1	0	1	0	0	43	
0	0	1	1	0	0	0	0	12	0	0	1	1	0	1	0	0	44	
1	0	1	1	0	0	0	0	13	1	0	1	1	0	1	0	0	45	
0	1	1	1	0	0	0	0	14	0	1	1	1	0	1	0	0	46	
1	1	1	1	0	0	0	0	15	1	1	1	1	0	1	0	0	47	
0	0	0	0	1	0	0	0	16	0	0	0	0	1	1	0	0	48	
1	0	0	0	1	0	0	0	17	1	0	0	0	1	1	0	0	49	
0	1	0	0	1	0	0	0	18	0	1	0	0	1	1	0	0	50	
1	1	0	0	1	0	0	0	19	1	1	0	0	1	1	0	0	51	
0	0	1	0	1	0	0	0	20	0	0	1	0	1	1	0	0	52	
1	0	1	0	1	0	0	0	21	1	0	1	0	1	1	0	0	53	
0	1	1	0	1	0	0	0	22	0	1	1	0	1	1	0	0	54	
1	1	1	0	1	0	0	0	23	1	1	1	0	1	1	0	0	55	
0	0	0	1	1	0	0	0	24	0	0	0	1	1	1	0	0	56	
1	0	0	1	1	0	0	0	25	1	0	0	1	1	1	0	0	57	
0	1	0	1	1	0	0	0	26	0	1	0	1	1	1	0	0	58	
1	1	0	1	1	0	0	0	27	1	1	0	1	1	1	0	0	59	
0	0	1	1	1	0	0	0	28	0	0	1	1	1	1	0	0	60	
1	0	1	1	1	0	0	0	29	1	0	1	1	1	1	0	0	61	
0	1	1	1	1	0	0	0	30	0	1	1	1	1	1	0	0	62	
1	1	1	1	1	0	0	0	31	1	1	1	1	1	1	0	0	63	

Address from 64 to 95								Address	Address from 96 to 127								Address
DIP S2					DIP S3				DIP S2					DIP S3			
1	2	3	4	5	1	2	3		1	2	3	4	5	1	2	3	
0	0	0	0	0	0	1	0	64	0	0	0	0	0	1	1	0	96
1	0	0	0	0	0	1	0	65	1	0	0	0	0	1	1	0	97
0	1	0	0	0	0	1	0	66	0	1	0	0	0	1	1	0	98
1	1	0	0	0	0	1	0	67	1	1	0	0	0	1	1	0	99
0	0	1	0	0	0	1	0	68	0	0	1	0	0	1	1	0	100
1	0	1	0	0	0	1	0	69	1	0	1	0	0	1	1	0	101
0	1	1	0	0	0	1	0	70	0	1	1	0	0	1	1	0	102
1	1	1	0	0	0	1	0	71	1	1	1	0	0	1	1	0	103
0	0	0	1	0	0	1	0	72	0	0	0	1	0	1	1	0	104
1	0	0	1	0	0	1	0	73	1	0	0	1	0	1	1	0	105
0	1	0	1	0	0	1	0	74	0	1	0	1	0	1	1	0	106
1	1	0	1	0	0	1	0	75	1	1	0	1	0	1	1	0	107
0	0	1	1	0	0	1	0	76	0	0	1	1	0	1	1	0	108
1	0	1	1	0	0	1	0	77	1	0	1	1	0	1	1	0	109
0	1	1	1	0	0	1	0	78	0	1	1	1	0	1	1	0	110
1	1	1	1	0	0	1	0	79	1	1	1	1	0	1	1	0	111
0	0	0	0	1	0	1	0	80	0	0	0	0	1	1	1	0	112
1	0	0	0	1	0	1	0	81	1	0	0	0	1	1	1	0	113
0	1	0	0	1	0	1	0	82	0	1	0	0	1	1	1	0	114
1	1	0	0	1	0	1	0	83	1	1	0	0	1	1	1	0	115
0	0	1	0	1	0	1	0	84	0	0	1	0	1	1	1	0	116
1	0	1	0	1	0	1	0	85	1	0	1	0	1	1	1	0	117
0	1	1	0	1	0	1	0	86	0	1	1	0	1	1	1	0	118
1	1	1	0	1	0	1	0	87	1	1	1	0	1	1	1	0	119
0	0	0	1	1	0	1	0	88	0	0	0	1	1	1	1	0	120
1	0	0	1	1	0	1	0	89	1	0	0	1	1	1	1	0	121
0	1	0	1	1	0	1	0	90	0	1	0	1	1	1	1	0	122
1	1	0	1	1	0	1	0	91	1	1	0	1	1	1	1	0	123
0	0	1	1	1	0	1	0	92	0	0	1	1	1	1	1	0	124
1	0	1	1	1	0	1	0	93	1	0	1	1	1	1	1	0	125
0	1	1	1	1	0	1	0	94	0	1	1	1	1	1	1	0	126
1	1	1	1	1	0	1	0	95	1	1	1	1	1	1	1	0	127

### Step 4: System Setting of Centralized Controller

SYSTEM SETTING includes ADDRESS SETTING and INITIALIZE SETTING. The former one is used for setting address of control object (communication module), and the latter one for initializing the data in the centralized controller (including clear all the finished address settings).

Since the centralized controller can control at most 64 communication modules and the address of them is 0 to 253 (0 is generally unused), it must specify the address of communication module needed to be controlled. It is ADDRESS SETTING, which is not recommended to operate by users.

The debugging personnel can press SYSTEM/DEBUG into system setting interface. After pressing UP, DOWN, LEFT or RIGHT button, press CONFIRM button into the interface for selection between ADDRESS SETTING and INITIALIZE SETTING.

#### The operation procedure of ADDRESS SETTING:

1) The centralized controller without energizing and setting will display following.

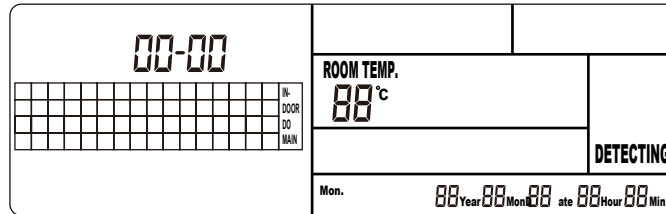

Display Present Unit No. 00-00 which means soft address 00-No. 00 indoor unit. (Soft address is the No. displayed in 1-64 grid of LCD).

Press SYSTEM/DEBUG into system setting interface. After pressing UP, DOWN, LEFT or RIGHT button, press CONFIRM button into the interface for selection between ADDRESS SETTING and INITIALIZE SETTING. Then press UP or DOWN button to switch between them.

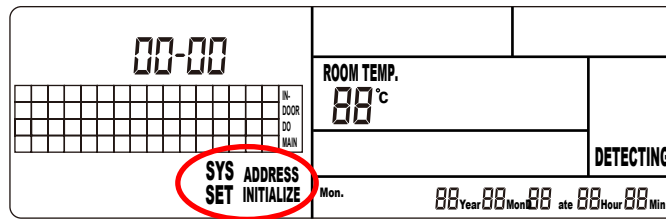

2) When ADDRESS SETTING is blinking, press SELECT button into address setting interface.

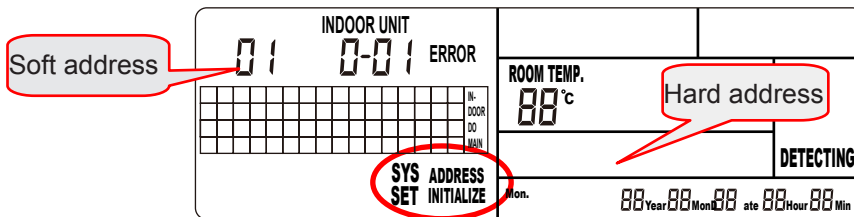

Press LEFT or RIGHT button to switch between SOFT and Hard ADDRESS settings, and UP or Down button to adjust their values. After adjustment, press CONFIRM button to make the address values corresponding and effective. If the cursor stops at hard address position (hard address is blinking), press CANCEL button to make the setting value ineffective, in which case, the “- -” will be displayed. (Soft address is the No. displayed in 1-64 grid of LCD and hard address is the actual one of communication module.)

In this example, the centralized controller controls 3 communication modules with the address of 01, 02 and 03 (i.e. hard address is 01,02 and 03). For convenient management, soft address will be set to the same as hard address, i.e. “01 001”, “02 002” and “03 003”.

If communication is normal after setting, the centralized controller will display as the following figure:

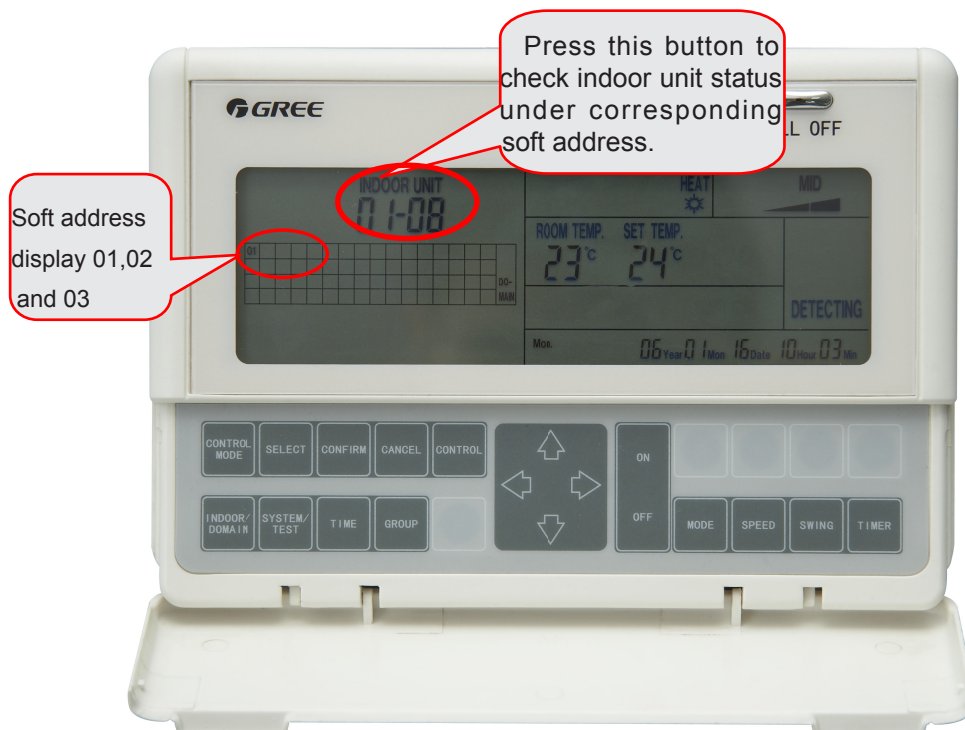

- ① .01,02 and 03 of soft address is displayed, which indicates normal communication of these 3 communication modules.
- ② . PRESENT UNIT NO. displays “01-08”, which indicates No. 08 indoor unit under 01 communication module is being checked.
- ③ . Press ROOM/REGION button to check other indoor units’ status under present communication module. Indoor units’ status is automatically detected, without setting in centralized controller.

### Step 5: Troubleshooting during Installation of Centralized Controller

Generally speaking, connection of communication lines, address DIP of communication module and address mapping setting of centralized controller are the common problems during installation of centralized controller. These problems can be reflected from running indicator (green) of communication module. Meanwhile, it is recommended to debug the centralized controller after making communication of outdoor and indoor units smooth to simplify the problems.

#### A. Connection of communication lines

1) If incorrect or non-connection of communication module, centralized controller and communication line of indoor and outdoor units, the green indicator will be black all the time.

2) It indicates connection problem between communication module and centralized controller that green indicator blinks once every 2s. In this case, COM2 must be used to connect them.

3) It indicates connection problem of communication module and indoor and outdoor units that green indicator blinks twice every 2s. In this case, COM1 must be used to connect them. Refer to Step 2, C for details.



#### B. Address DIP of communication module

There are two methods for address setting. The one is that communication module has been set by software store, but the 3-digital DIP switch can not be dialed to OFF completely. The other one is to set it manually, but the 3-digital DIP switch should be dialed to OFF completely. Refer to step 3 for details.

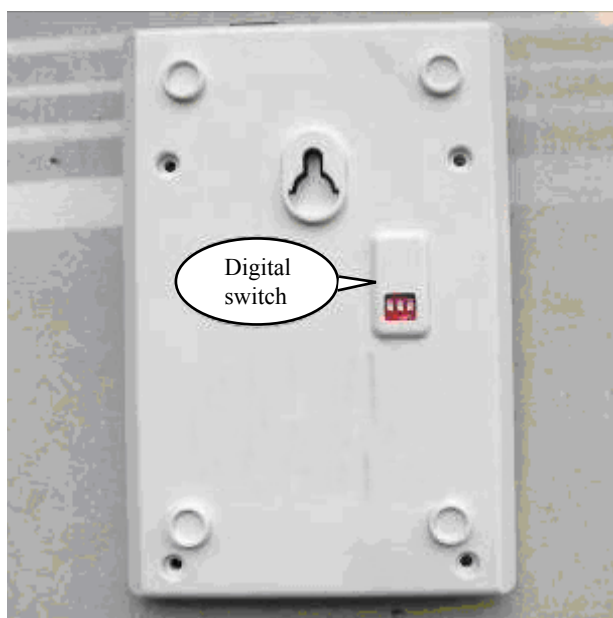

#### C. Address mapping setting of centralized controller

The centralized controller only can normally operate after specifying address of communication module needed to control. If not, the operation status of communication and indoor units can not be displayed by it. Refer to Step 4 for details.

## 7 MONITORING SOFTWARE

### 7.1 Remote Monitoring System

#### 7.1.1 Introduction to Remote Monitoring System

The great development of Gree's technology for manufacturing commercial air conditioners enables Gree to provide remote monitoring system for Gree commercial air conditioners to users which can solve the problem of difficulty on centralized management and maintenance caused by complex and disperse distribution of commercial air conditioners in a building. Users can execute daily management and maintenance to the units by the system which is easily operated and reliable.

Combining with technologies for electrommunication and computer software, remote monitoring system of Gree commercial air conditioners can collect information, inspect running status, and execute control and error warning of the commercial air conditioners. It can apply with a variety of types of commercial air conditioners, such as Multi VRF Units, Centrifugal Units, Air-Cooled Screw Chiller, Water-Cooled Screw Chiller, Closed Control Units, Modular Units, and Air Duct Type Units, etc. It can also meet the requirements of various building projects in the aspect of centralized management and monitoring for commercial air conditioners, which is indispensable high-tech product for intelligent control and information-based management of the modern building.

#### 7.1.2 Function Instruction to Remote Monitoring System

Remote monitoring system of the Multi VRF units can remote monitor all models of Gree current luxury Multi VRF units. In comfortable office, user can centrally manage and control max. 255 sets of Multi VRF units by software installed in monitoring computer. Specific models applied with the system are: 1-16 indoor units of Multi VRF units, R410A heat recovery, single unit inverter of Multi VRF, modular Multi VRF units, 900 digital Multi VRF, R22 digital heat pump units, 1-32 digital Multi VRF units.

It is capable of remotely turning on/of the unit, modifying the mode, changing the settings, altering the fan speed, and enquiring the status of the unit etc .through the remote monitoring system/BMS system.

#### 7.1.3 Product Accessories List

Note: The remote monitoring system GREE AC Eudenmon 2009 should be coupled with the latest communication module MC200017 (ZJ6012).

Name	Model	Material Code	Scope of Supply	Remarks
Optoelectronic isolated repeaters	Optoelectronic isolated repeaters RS485 Top	LN02200010	Optional	Optional only when meeting the condition
Communication module kit	ME30-23/E(M)	MC200017	Standard	For export, including communication module
components of remote monitoring system of Centrifugal units	FC30-23/A(M)	MC200019	Standard	Include CD of monitoring software, optoelectronic isolated converter, etc.

### 7.2 BMS System

#### 7.2.1 General Description of BMS System

The BMS system of Gree's central air conditioner adopts RS485 communication mode and provides the prevailing MODBUS protocol. Via MODBUS standard protocol interface, Gree's central air conditioner can be seamlessly interfaced to the building management system (BMS).

This system is applicable to centralized monitoring and management of GMV multi VRF system, water cooled screw chiller, air cooled scroll chiller and centrifugal chiller. It is a requisite system for managing the intelligent air conditioner system in modern buildings.

The BMS of GMV multi VRF system can provide BMS interface for Gree's multi VRF system. Via this interface, the user can execute centralized management and control of 4080 indoor units under 255 sets of GMV multi VRF systems. It is a requisite system for management of the intelligent air conditioner system in modern buildings. This system is applicable to the following models: 1-16 GMV indoor unit, R410A Heat Recovery Unit, Non-modular Inverter GMV, Modular GMV, 900 Digital GMV, R22 Digital Heat Pump Water Heater and 1-32 Digital GMV.



### 7.2.2 Function Instruction of BMS System

- ◆ Realize the perfect connection with other network by connecting the RS485 main interface to the user's BMS system under the involvement of the Modbus protocol.
- ◆ Realize the monitoring on the settable parameter of the unit.
- ◆ Realize the monitoring on the running status of the unit.
- ◆ Realize the monitoring on the error status of the unit.
- ◆ Be of multiple monitoring points, allowing up to 255 units in one network.

### 7.2.3 Product Accessories List

**Notes: When Gree provides BMS interface module only, so that the user needs to integrate the building management system (BMS) by himself according to interface protocol.**

Name	Model	Material Code	Range of Supply	Remarks
Optoelectronic isolated converter	Optoelectronic isolated converter GD02	EN02200020	Optional	For export
Optoelectronic isolated repeater	Optoelectronic isolated repeater RS485	LN02200010	Optional	Optional only when meeting the condition
Communication module kit	Remote control parts ME30-00/E2	MC200030	Standard	For export, including communication module

In conclusion: Refer to the service manual for more details about the interface of the remote monitoring system and BMS system (File No.: JF00300218 & JF00300219). If product specification has the modification, our company will not issue a separate notice.

## 8 DETECTION CONTROL BOARD

### 8.1 Gate-control Function

This detection control board is only suitable for Gree multi-variable (GMV) indoor unit with gate-control function. The AC will run after plugging in gate-control card and stop running after plugging out the card. Upon plugging out the card to stop the unit, the running states of the unit will be memorized. After plugging in the card, the unit will be under standby state or resume running according to settings. The AC will run when the customer plugs in the card and automatically stop when he plugs out the card, which ensures unit off after leaving of persons and saves energy.

Fig.1 is about simple sketch for communication network of detection control board for GMV series.

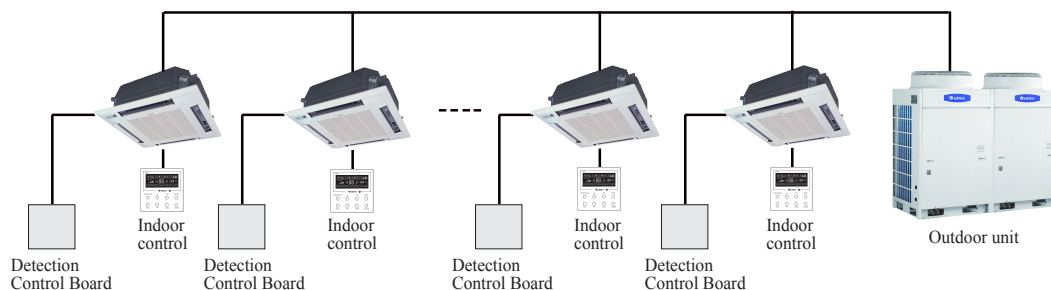

Fig.1 Communication Network of Detection Control Board for GMV series

### 8.2 Working Process of Gate Control

1) If the gate-control card is not plugged in after powering on the complete unit, the indoor unit will be in the state without gate-control function and can be operated by remote controller or buttons on it.

2) Powering on the AC and plugging in the card, the unit will be in the state with gate-control function after 5-second detection. The present running state of the AC won't be affected (the unit on/off state will be kept) after plugging in the card. If plugging out the card, the AC will automatically stop after 5-second detection.

Once plugging in the card, indoor unit will be considered as the one with gate-control function, which can be canceled only after powering off and then powering on the unit.

8.3 Detection Control Board Interface Sketch is shown in Fig.2:

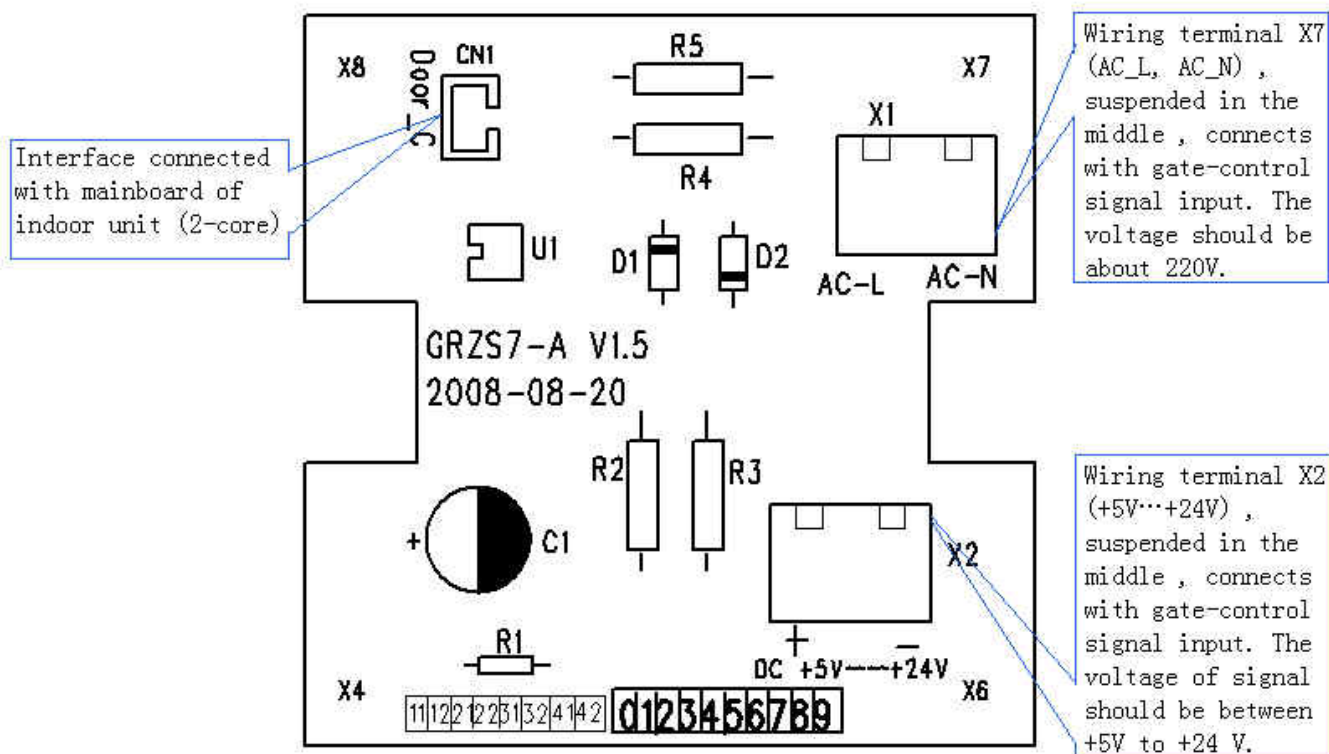

Fig2: Detection Control Board Interface Sketch

The gate-control function can be realized after the detective interface of detection control board connects with interface of gate-control card and signal interface of it connects with the mainboard.

8.4 Products Parameters

- Model: MK03 gate controller
- Working Voltage: AC 220-240V, 50HZ or DC +5V-+24V
- Power: 1W
- Working temperature: -10~48°C

8.5 Installation of Detection Control Board

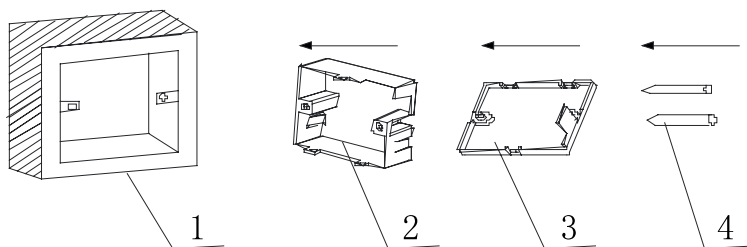

Fig. 3 Installation Sketch of Detection Control Board

No.	1	2	3	4
Description	Base box of socket installed in the wall, a hole with (L×W×D)100mm×100mm×50mm	Bottom plate of detection control board	Front panel of detection control board	Screw M4X25

Note: Detection control board with (L×W×H) 73.5mm×73.5mm×33.0mm

Fig.3 is about installation process of detection control board. The following items should be attended.

1. Installation must be performed by professionals. Either 220-240V or DC 5-24V is ok.
2. Cut off the power of heavy current wire covered in the mounting hole in the wall before installation. Never perform the installation with electricity.
3. Press the bottom plate of the detection control board on the wall, and then make it and front panel of detection control board together.
4. At last fix the bottom plate and front panel of detection control board together with screw ST2.2X6.5.
5. There shouldn't be any large-power electric appliance and firming base nearby to avoid interference source.
6. Avoid sunlight and rain and do not install it at wet space.
7. Do not install the unit at the place where there is corrosive gas, serious dust, salt fog and oil smoke or which is specially wet.
8. The detection control board must be installed at concealed place and far from water and fire.

# INSTALLATION





# INSTALLATION

## 1 PRECAUTIONS FOR INSTALLATION

### 1.1 Precautions for Safety

◆ Before installation, please ensure if the installing site, power ratings, possible operating range (pipe distance, height difference between indoor and outdoor unit, power voltage) and installing space are correct and suitable. The outdoor unit is general to all models according to its power.

◆ To ensure correct installation, please make sure to read the Safety Considerations thoroughly before starting the installation works

◆ The considerations stated below are classified into  WARNING and  CAUTION. Those that might cause death or severe injury in case of wrong installation are identified in  WARNING. However, those that are stated in  CAUTION may also cause severe accidents sometimes. Therefore, both of them relate to important safety considerations and must be strictly followed.

◆ After completing the installation and test run and confirming that all are normal, please introduce to the client on how to use and repair the machine according to the Operating Instructions. Besides, please deliver the considerations herein to the clients together with the Operating Instructions, and ask them to keep properly.

#### **WARNING!**

◆ The installation shall be performed by the vendor or professional dealer from which you buy the machine. If you install by yourself, any improper installation might cause water leakage, electric shock or fire accident.

◆ The installation shall be done correctly according to installation instructions. Improper installation may cause water leakage, electric shock or fire.

◆ To install a large air-conditioning system in a small room, please make sure to take measures to prevent that the refrigerant will not exceed the limit concentration in case of leakage. For the measures to prevent the refrigerant from exceeding the limit concentration, please consult your dealer. If no proper measures, it might cause human suffocation in case of refrigerant leakage

◆ Please install at a position that is strong enough to support the weight of machine. If the installing position is of low strength, the machine may drop down and thus cause human injury.

◆ Please carry out installation in accordance with the rules for preventing the typhoon or earthquake. The machine may tip over if the installation does not comply with the requirements.

◆ The electrical cabling shall be carried out by qualified electricians in accordance with the Safety Code for Electrical Equipment, relevant local rules and the installation instructions. Make sure to use the special-purpose circuit. If the power circuit capacity is low or the construction is improper, it might cause electric shock or fire accidents.

◆ Please use suitable cables and connect them securely. Please fix the terminal joints securely. The terminal connection shall not be affected due to any external force applied onto the cable. Improper connection and fixing may cause heating and fire accidents

◆ Keep the cables in correct shape and prevent them from protruding upward. Please protect them securely with repair board. Improper installation may cause heating and fire accidents.

◆ When erecting or relocating the air conditioner, do not let any air enter into cooling circulation system except the specified refrigerant. If any air is mixed, abnormal high pressure will occur in the cooling circulation system, thus causing crack or human injury accidents.

◆ During installation, please always use the attached parts or designated parts. Failure to use the designated parts may cause water leakage, electric shock, fire or refrigerant leakage.

#### **CAUTION**

◆ Please earth securely. Do not connect the earth wires to gas pipe, water pipe, lightning rod or telephone line. Improper earthing might cause electric shock.

◆ Leakage circuit breaker must be installed at some place. No installation of leakage circuit breaker might cause electric shock.

◆ Do not install at a place where inflammable gas might leak. Gas leakage and despot around the machine might cause fire accidents.

◆ To ensure correct drainage of water, the drainage pipe shall be installed according to the installation instructions. Also the heat insulation shall be provided to avoid condensing. Improper installation of the pipe

might result in water leakage and lead to possible wetting of the articles in the room.

## 1.2 Key Points of Installation

Installation Procedures			Description and Acceptance Criteria
Material Selection and Equipment Inspection			<ol style="list-style-type: none"> <li>1) The materials specified on the engineering drawing shall be purchased as specified (e.g. copper tube, thermal insulation tube, PVC pipe, power cables, air switch, etc);</li> <li>2) The materials not specified on the engineering drawing shall be purchased according to the actual quantity of works (e.g. hanger frame, cable duct, etc);</li> <li>3) Check if the outdoor unit, indoor unit, communication wires and accessories are complete.</li> </ol>
Installation of indoor unit	Communication wire	Connection	<ol style="list-style-type: none"> <li>1) The power cables shall be separated from communication wires at a least distance of 10cm.</li> <li>2) To avoid breaking the communication wires, please do not use strong force;</li> <li>3) For multiple units, please mark them properly.</li> <li>4) Switch on indoor and outdoor unit, and ensure there is no display of "Communication Wire Error E6".</li> </ol>
		Address dial code	<ol style="list-style-type: none"> <li>1) Each indoor unit under the same system has a unique address dial code.</li> <li>2) The wired controller and its corresponding indoor unit have the same address dial code.</li> </ol>
	Remote Control		<ol style="list-style-type: none"> <li>1) Select the remote control mode;</li> <li>2) The centralized controller and communication module shall be installed free from the source of interference.</li> </ol>
	Power cord		<ol style="list-style-type: none"> <li>1) The power cable must meet the specifications.</li> <li>2) The indoor units under the same system must be arranged under unified power supply.</li> </ol>
	Drainage Pipe	Installation	<ol style="list-style-type: none"> <li>1) The PVC pipes must meet the specifications.</li> <li>2) A specific gradient must be provided along the water flow direction.</li> <li>3) Carry out water detection after installation.</li> <li>4) Carry out thermal insulation to the drainage pipe only after the water detection is accepted.</li> </ol>
		Thermal insulation	<ol style="list-style-type: none"> <li>1) The thermal insulation tube must meet the specifications.</li> <li>2) Seal between the thermal insulation pipes to avoid air entry.</li> </ol>
	Installation of Air Duct (when with high static pressure duct-type unit)		<ol style="list-style-type: none"> <li>1) Design the length of air duct according to static pressure;</li> <li>2) The air inlet shall be optimally designed to avoid too small size.</li> </ol>
Installation of connection pipes	Welding		<ol style="list-style-type: none"> <li>1) The copper tube must meet the specifications.</li> <li>2) Ensure it is dry and clean inside the tube.</li> <li>3) Make sure to charge nitrogen as required for protection when welding the tubes.</li> <li>4) Please keep to the welding process and ensure the system free of leakage.</li> <li>5) Add a dual-way filter on liquid pipe side.</li> <li>6) For multiple systems, please mark them properly.</li> <li>7) Carry out leakage detection under pressure after welding.</li> </ol>
	Purge and make leakage detection under pressure		<ol style="list-style-type: none"> <li>1) Purge the system clean.</li> <li>2) Keep the pressure for 24 hours.</li> <li>3) Except for the influence by temperature, it is deemed acceptable if pressure drop is within 0.02MPa. (With the temperature change by 1°C, the pressure will change by approx. 0.01MPa).</li> </ol>
	Thermal insulation		<ol style="list-style-type: none"> <li>1) The thermal insulation tube must meet the specifications.</li> <li>2) Seal between the thermal insulation pipes to avoid air entry.</li> </ol>
Installation of outdoor unit			<ol style="list-style-type: none"> <li>1) Select the installing position correctly.</li> <li>2) Build the foundation according to the anchor bolt position and the dimension of outdoor unit;</li> <li>3) Build the damping device properly.</li> <li>4) Avoid sharp knock when handling the outdoor unit. The inclination angle shall not be higher than 15°.</li> </ol>
Connection of indoor unit and outdoor unit			<ol style="list-style-type: none"> <li>1) Tighten the nuts;</li> <li>2) Provide proper protection to the outdoor connection pipe, communication wires and power supply.</li> </ol>
Leakage detection under pressure			<ol style="list-style-type: none"> <li>1) Keep the pressure for 24 hours. Except for the influence by temperature, it is deemed acceptable if pressure drop is within 0.02MPa. (With the temperature change by 1°C, the pressure will change by approx. 0.01MPa).</li> </ol>
Vacuuming			<ol style="list-style-type: none"> <li>1) Establish vacuum simultaneously in the gas pipe and liquid pipe;</li> <li>2) The vacuuming time shall be long enough.</li> <li>3) Put still for 1 hour after vacuuming. It is deemed acceptable if the pressure will not rise.</li> </ol>
Add refrigerant			Add refrigerant according to the volume as specified on the engineering drawing.
Open the valve of outdoor unit			
Commissioning of complete unit			

**Remarks:**

- 1) Described above are general working procedures. The procedures might vary with the site conditions.
- 2) For detailed installation rules, please see the description in each chapter.

**2 FLOW CHART OF INSTALLATION**

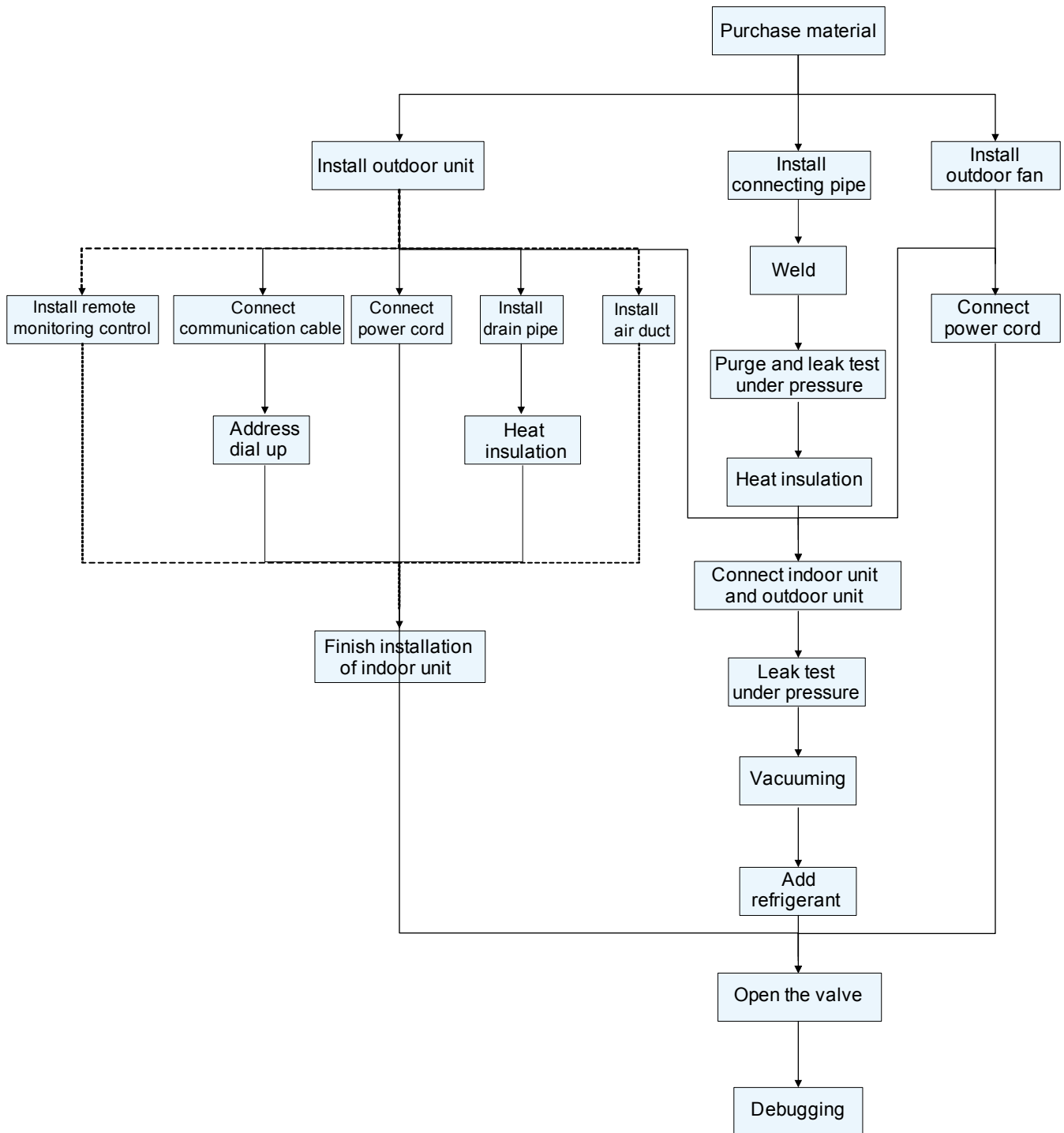

### 3 INSTALLATION OF OUTDOOR UNIT

#### 3.1 Hoisting of Unit

Transport the unit to a place as close as possible to the installing site before taking it out of the packaging box.

**⚠ CAUTIONS!**

- Never put any object on top of the unit before and after installation.
- To lift the machine with crane, please use two ropes to lift the outdoor unit.

◆ Hoisting Method

The machine must be balanced when it is lifted. Check and ensure that the machine can be lifted up safely and stably.

**⚠ CAUTIONS!**

- Do not attach the ropes to the lower wood frame of the packaging box.
- Never remove any packaging materials.

◆ As shown, insert two ropes through the square holes on the machine and protect the machine with batten and corrugated paper.

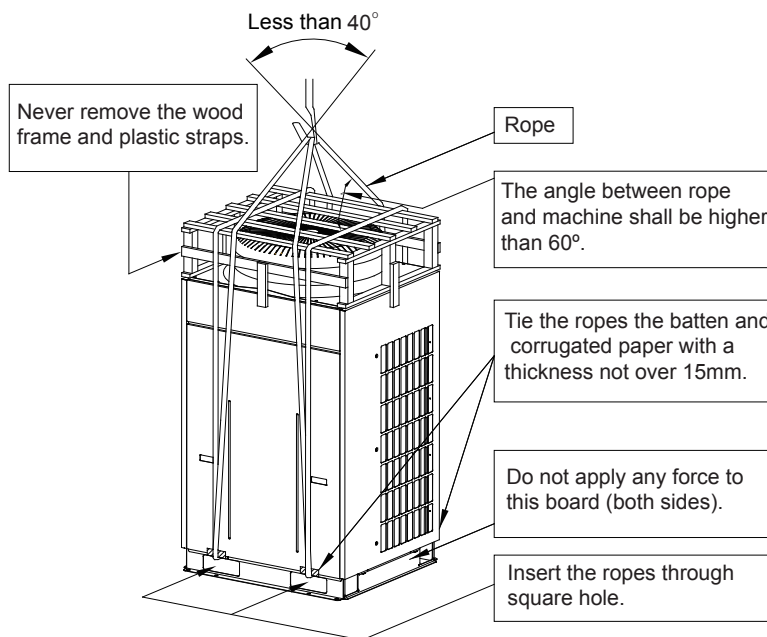

- ◆ During lifting, the position of ropes is as shown below.
- ◆ Move the lower wood frame of the packaging box away and lift the unit to correct position.

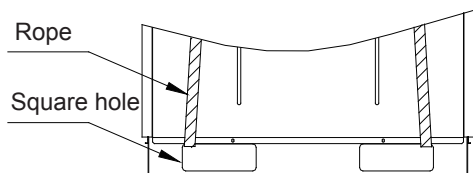

Correct

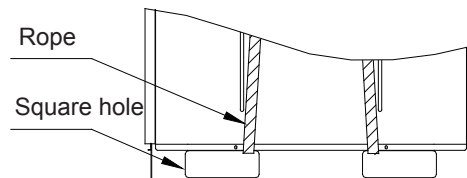

Correct



### 3.1 Installation of Outdoor Unit with Side Air Outlet

To ensure good operation of the air conditioner, the selection of installing position must be in accordance with the following principles:

- ◆ The air discharged from the unit will not flow back, and there shall be adequate service space around the machine.
- ◆ The installing position shall be in good ventilation, so that the machine can breathe and exhaust enough air. Ensure that there is no obstruction at the inlet and outlet of the machine. If any, please remove the obstructions blocking the air inlet and outlet.
- ◆ The installing position shall be strong enough to withstand the weight of outdoor unit and be able to isolate the sound and absorb the vibration. Also ensure that the outlet air and noise from the air conditioner will not affect the neighbors.
- ◆ The outdoor unit must be lifted by using the designated lift hole. During lifting, take care to protect the air conditioner and avoid knocking the metal parts, thus to prevent rusting in the future.
- ◆ Avoid direct sunshine as it might be.
- ◆ The installing position must be able to drain the rainwater and the water generated from defrosting.
- ◆ The installing position must ensure that the machine will not be buried in the snow or affected by the wastes or oil mist.
- ◆ To meet the noise and vibration requirements, the outdoor unit shall be installed by using rubber damping pad or spring damper.
- ◆ The installing dimension shall comply with the installation requirements in these instructions. The outdoor unit must be fixed at the installing position.
- ◆ The installation shall be done by specialist technicians.

### 3.2 Selection of Installation Site

- ◆ The place with no residual air
- ◆ The place where the accessories can be securely fixed
- ◆ The place where the air will not obstruct the water inlet pipe or water outlet pipe
- ◆ The place that goes beyond the heating range of other heat sources
- ◆ The place where the wastewater can be safely drained
- ◆ The place where the noise and hot air will not affect the neighbors
- ◆ The place where the snow will not be piled
- ◆ The place where the water outlet pipe will not be blown by strong wind

**Note:**

- ◆ Do not use guardrail on four sides. Leave 1m at least above the machine.
- ◆ In case of short-circuit risk, please install an adaptor changeable in air direction.
- ◆ To avoid short circuiting, please provide adequate suction space when multiple machines are to be installed.
- ◆ In the region with snow, the machine shall be installed in a frame or beneath the snow guard, thus to prevent snow piling on the machine.
- ◆ Do not install the equipment in a region where any inflammable gas might leak.
- \* The snow guard and other devices shall be designed and installed by the user.

### 3.3 Dimensions Data

**NOTE:**The picture of the units is only for reference, everything goes by with the real object.

GMV-Pdm224W/NaB-M, GMV-Pdm280W/NaB-M, Outline dimensions. (Unit: mm)

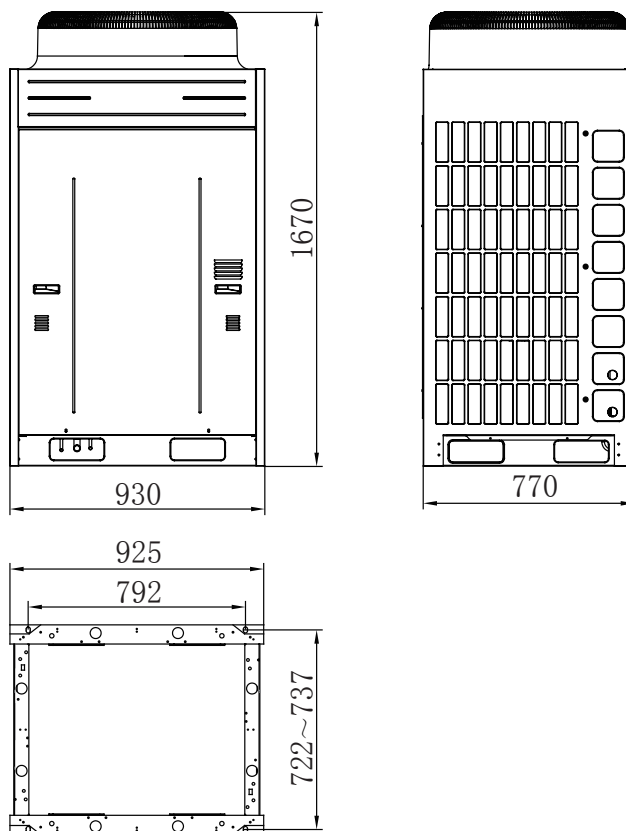

GMV-Pdm335W/NaB-M, GMV-Pdm400W/NaB-M, GMV-Pdm450W/NaB-M, Outline dimensions. (Unit: mm)

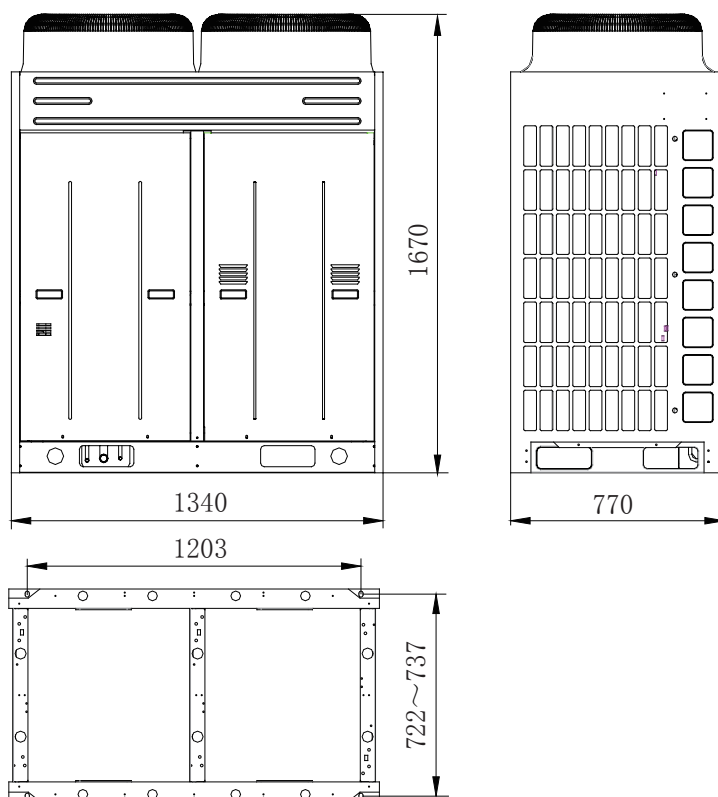

### 3.4 Clearance Data

**NOTE:**The picture of the units is only for reference, everything goes by with the real object.

#### 3.4.1 Clearance data of single unit

GMV-Pdm224W/NaB-M, GMV-Pdm280W/NaB-M, GMV-Pdm335W/NaB-M, GMV-Pdm400W/NaB-M, GMV-Pdm450W/NaB-M, Outline dimensions. (Unit: mm)

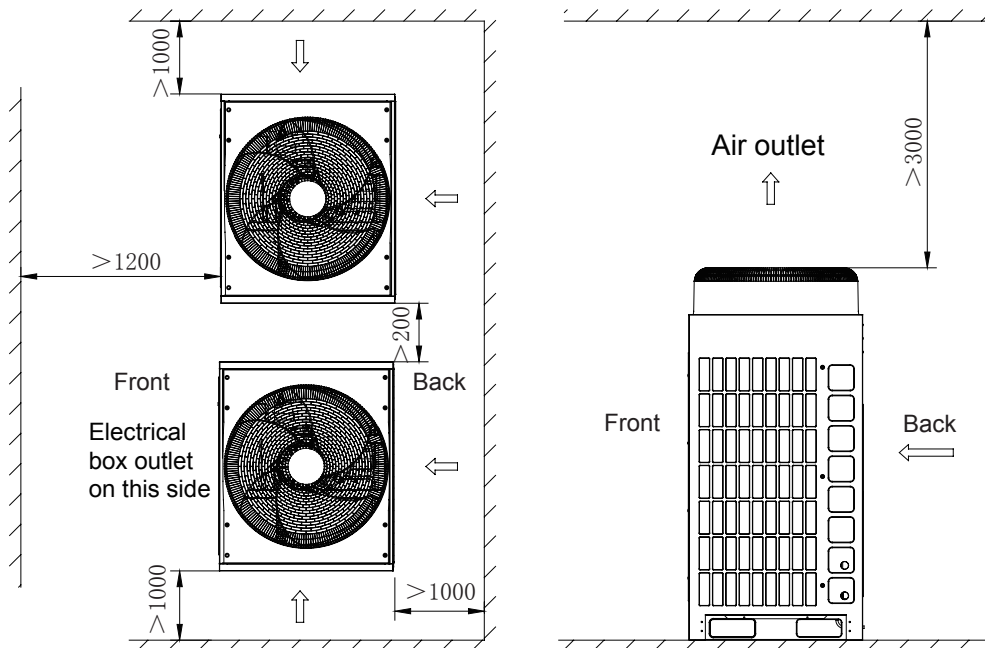

The wall on the four side of the outdoor unit should be in accordance with the above basic space requirement;

In case that the front side and left side (or right side) of the outdoor unit is open space:

No limitation to the height of the wall

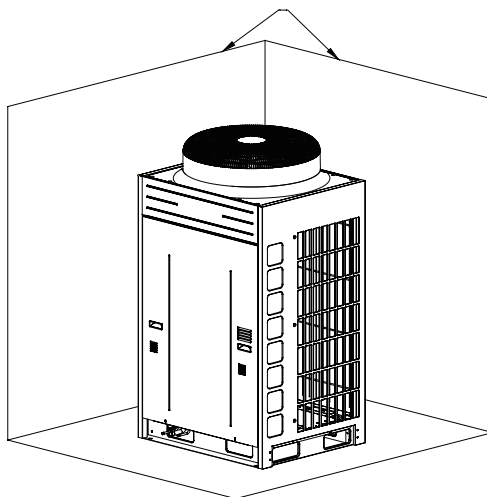

For the top wall (e.g. air guard interference), it is required over 3000mm distance between the unit top and the top wall in principle. In case that the front, back, left and right sides are open to the around space, it is required over 1500mm distance between the unit top and the top wall. In case the distance is less than 1500mm, or the unit is not open to the around space, a air inlet is necessary for keeping ventilation

### 3.4.2 Clearance data of multiple unit

To ensure good ventilation, the top of unit shall be kept open and free of any obstructions. In case that the front side and left side (or right side) of the outdoor unit is open space, the unit shall be installed in the same direction.

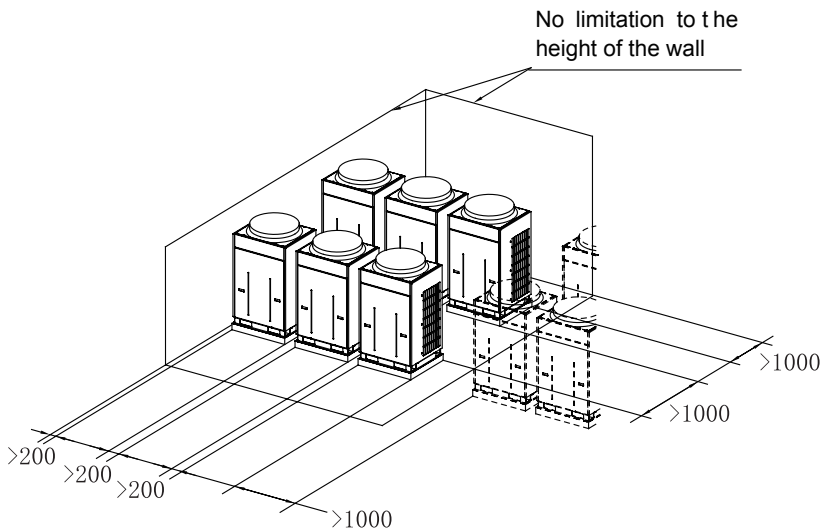

Installed back against back:

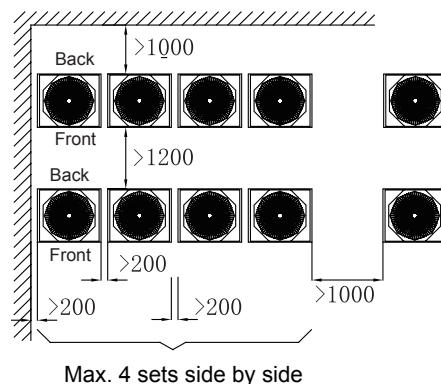
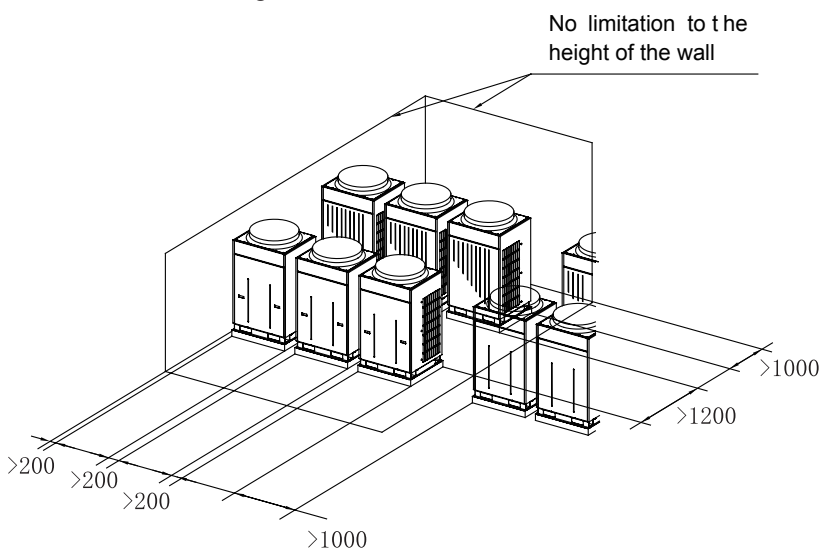
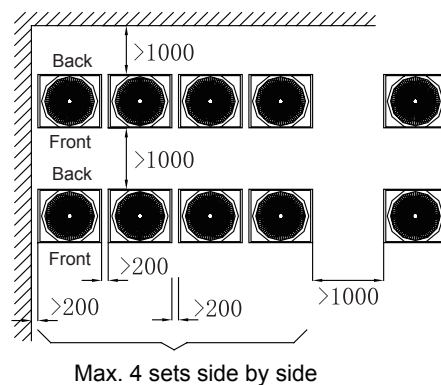

In case there are walls on four sides of the outdoor unit: It is suggested to install the unit in the same direction

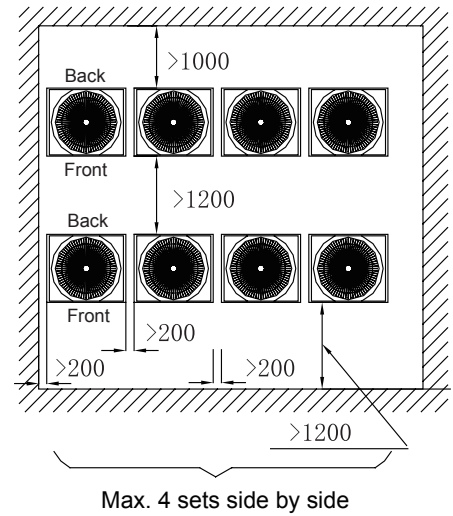
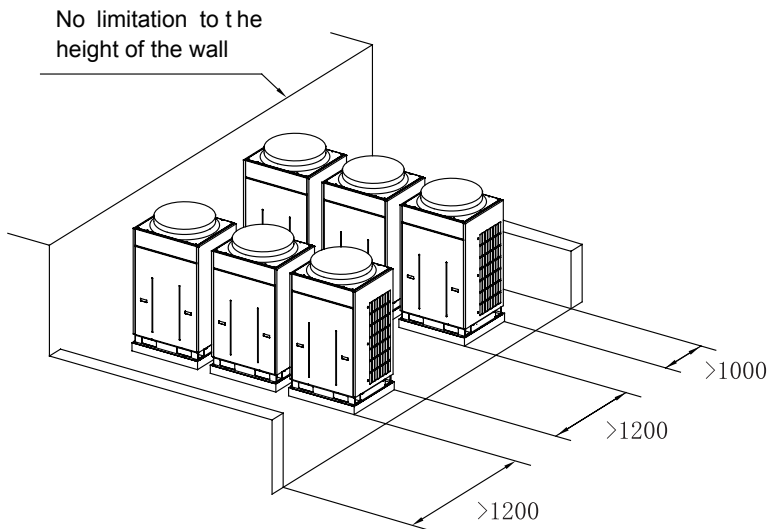

### 3.5 Take Monsoons and Snow into Consideration

The monsoon shall be taken into consideration when installing the outdoor unit.

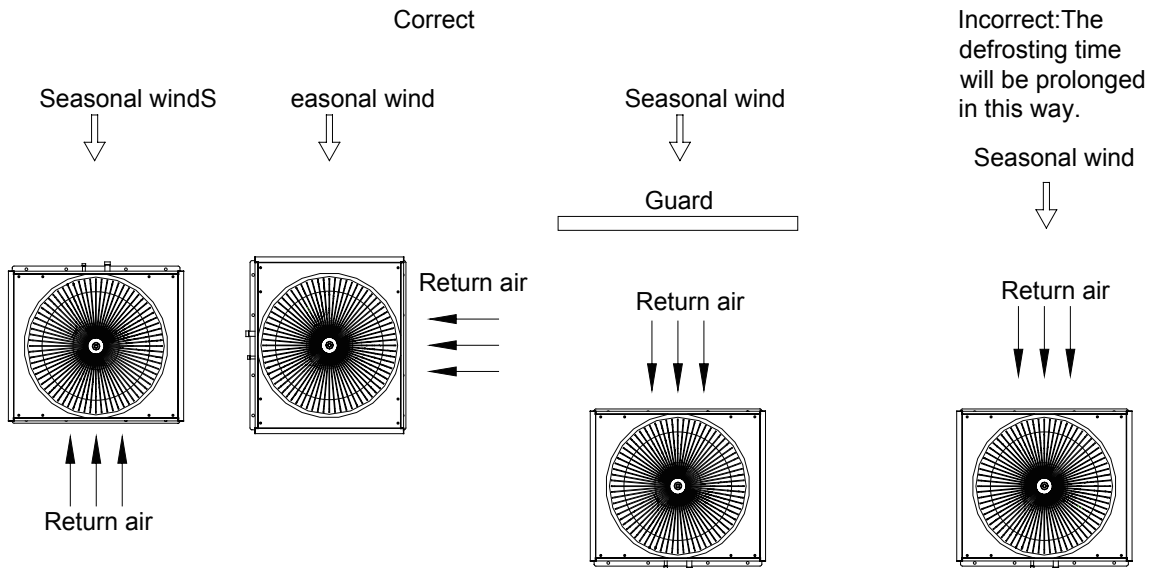

The snow shall be taken into consideration when installing the outdoor unit.

To prevent the snow from covering the air outlet and air inlet, it is required to use a protective cover on air outlet and air inlet, and use a higher foundation base.

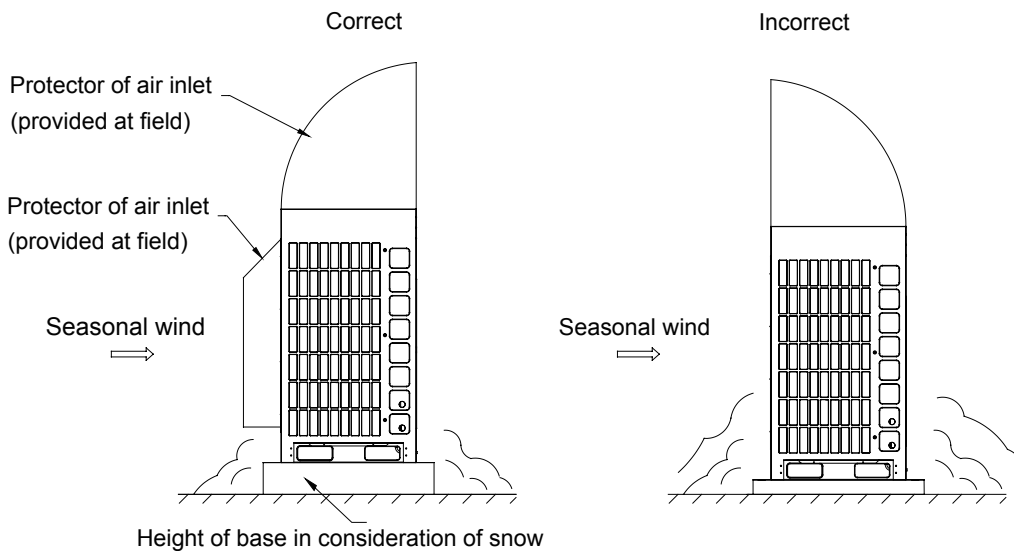

## 4 INSTALLATION REQUIREMENTS OF REFRIGERANT PIPING

### 4.1 Specification

R410a refrigerant system			
External Diameter(mm/inch)	Thickness(mm)	External Diameter(mm/inch)	Thickness(mm)
φ6.35	≥ 0.8	φ25.4	≥ 1.5
φ9.52	≥ 0.8	φ28.6	≥ 1.5
φ12.7	≥ 1	φ34.9	≥ 1.5
φ15.9	≥ 1	φ41.3	≥ 2.0
φ19.05	≥ 1	φ44.5	≥ 2.0
φ22.2	≥ 1.5	φ54.1	≥ 2.0

### 4.2 Allowable Length and Height Differences of the Refrigerant Piping between the Indoor and Outdoor Units

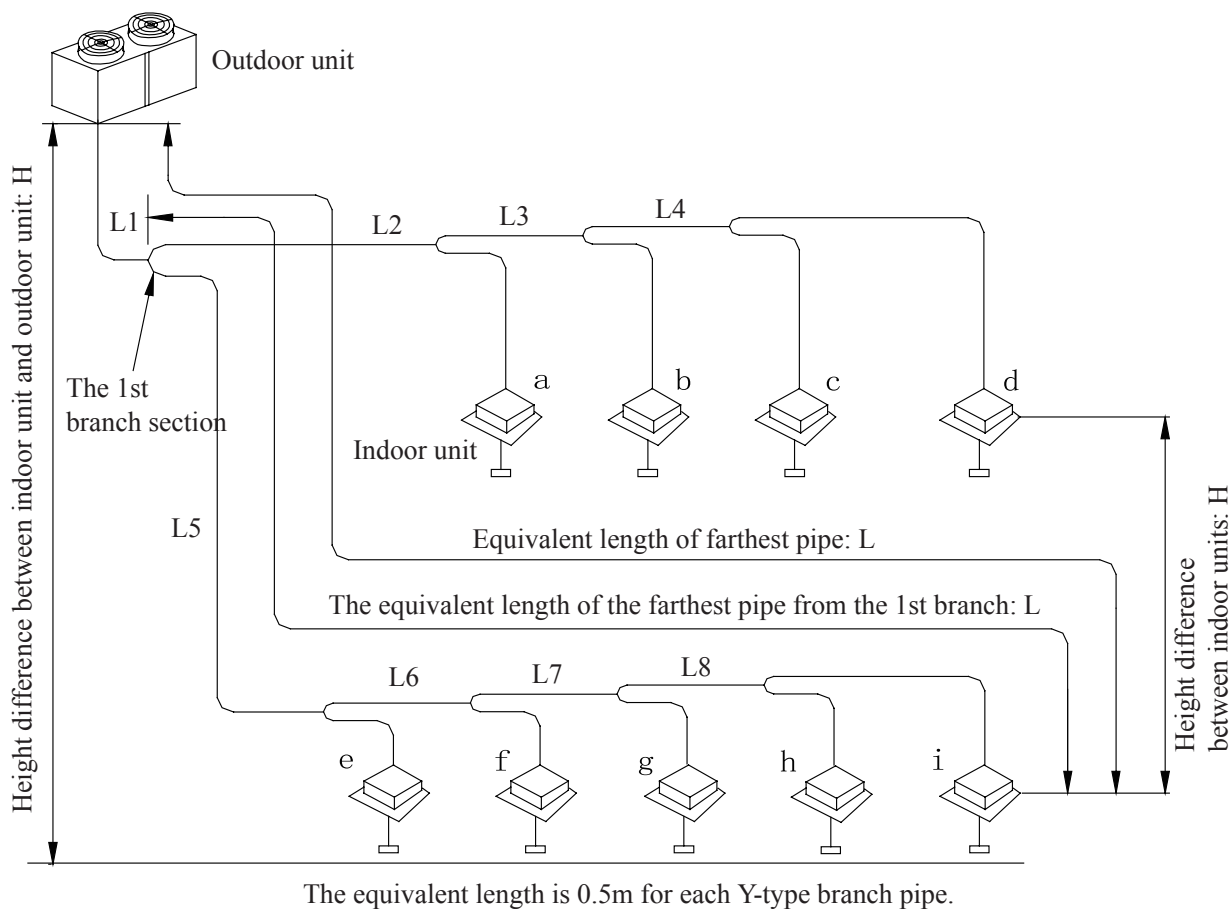

4.2.1 For outdoor unit with total rated capacity more than or equal to 60.0kW (See the above picture for the piping methods)

		Allowable (m/ft) value	Fitting pipe
Total length (actual length) of fitting pipe		500	$L1+L2+L3+L4+\dots+L8+a+b+\dots+i$
Length of the furthest fitting pipe	Actual length	150	$L1+L5+L6+L7+L7+ L8+i$
	Equivalent length	175	
Equivalent length of fitting pipe from the 1st branch joint to farthest indoor unit L(m)		40	$L5+L6+L7+L7+ L8+i$
Height differences between indoor unit and outdoor unit	Outdoor unit at upper	50	—
	Outdoor unit at lower	40	—
Height differences between indoor units		15	—

4.2.2 For outdoor unit with total rated capacity more than or equal to 20.0kW and less than 60.0kW(See the above picture for the piping methods)

		Allowable (m/ft) value	Fitting pipe
Total length (actual length) of fitting pipe		300	$L1+L2+L3+L4+\dots+L8+a+b+\dots+i$
Length of the furthest fitting pipe	Actual length	100	$L1+L5+L6+L7+L7+ L8+i$
	Equivalent length	125	
Equivalent length of fitting pipe from the 1st branch joint to farthest indoor unit L(m)		40	$L5+L6+L7+L7+ L8+i$
Height differences between indoor unit and outdoor unit	Outdoor unit at upper	50	—
	Outdoor unit at lower	40	—
Height differences between indoor units		15	—

### 4.3 Refrigerant Pipe Size

4.3.1 The refrigerant pipe size from the outdoor unit to the first branch is decided by the capacity code of the outdoor unit.

**Note:**

- ① . When the distance between the outdoor unit to the farthest indoor unit exceeds 90m, then the size of both the liquid and gas refrigerant pipes between the outdoor unit to the first branch should be enlarged by one level as listed in the following table.
- ② . When the distance between the first branch to the farthest indoor unit exceeds 40m, then the size of the liquid refrigerant pipe between the first branch to the farthest indoor unit should be enlarged by one level as listed in the following table.

4.3.2 The diameter of the piping between branch joints (the branch pipe)

R410a refrigerant system		
Outdoor capacity code C	Gas pipe (mm/inch)	Liquid pipe(mm/inch)
$C \leq 56$	$\Phi 12.7$	$\Phi 6.35$
$56 < C \leq 142$	$\Phi 15.9$	$\Phi 9.52$
$142 < C \leq 220$	$\Phi 19.05$	$\Phi 9.52$
$220 < C \leq 300$	$\Phi 22.2$	$\Phi 9.52$
$300 < C \leq 450$	$\Phi 28.6$	$\Phi 12.7$
$450 < C \leq 670$	$\Phi 28.6$	$\Phi 15.9$
$670 < C \leq 950$	$\Phi 34.9$	$\Phi 19.05$
$950 < C \leq 1350$	$\Phi 41.3$	$\Phi 19.05$
$1350 < C \leq 1600$	$\Phi 44.5$	$\Phi 22.2$
$1600 < C \leq 2100$	$\Phi 54.1$	$\Phi 25.4$

**Note: When the actual pipe length exceeds 90m, the pipe diameter shall be increased accordingly.**

4.3.3 The diameter of the piping from the branch joint (branch pipe) to the indoor unit

R410a refrigerant system		
Outdoor capacity code C	Gas pipe (mm/inch)	Liquid pipe(mm/inch)
22,25,28 model	$\Phi 9.52$	$\Phi 6.35$
36,40,45,50 model	$\Phi 12.7$	$\Phi 6.35$
56,63,71,80,90,100,112,125,140 model	$\Phi 15.9$	$\Phi 9.52$

**Note: When the actual pipe length exceeds 90m, the pipe diameter shall be increased accordingly.**

### 4.4 Selection of Y-Type Branch Pipe

R410a refrigerant system	Total Capacity of the Downstream Indoor Unit (X)	Model
Y-Type Branch Pipe	$X \leq 200$	FQ01A/A
	$200 < X \leq 300$	FQ01B/A
	$300 < X \leq 700$	FQ02/A
	$700 < X \leq 1350$	FQ03/A
	$1350 < X$	FQ04/A



## 4.5 Selection of Refrigerant Piping between Outdoor Unit and Outdoor Unit ( for module unit)

### 4.5.1 Selection of components between module and module

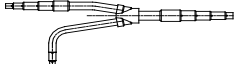
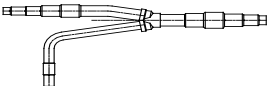
Notes	Model	Name	Illustration
Sub-assembly corresponding to outdoor module	ML01/A	ML01- Liquid pipe	
		ML01- Air pipe	

### 4.5.2 Selection of pipe diameter between module and module

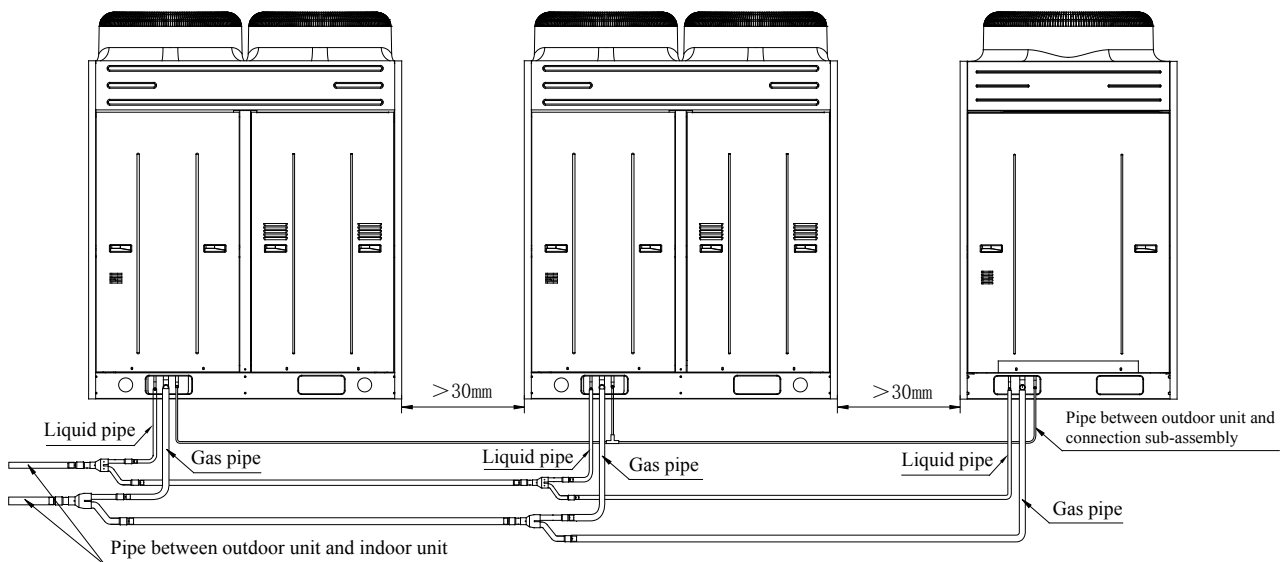

#### 4.5.2.1 Pipe diameter between outdoor unit and connection component

R410a refrigerant system		
Single module capacity code C	Gas pipe (mm/inch)	Liquid pipe(mm/inch)
$C \leq 280$	$\Phi 22.2$	$\Phi 9.52$
$280 < C \leq 45$	$\Phi 28.6$	$\Phi 12.7$

#### 4.5.2.2 Pipe diameter between connection component of module and connection component of module

R410a refrigerant system		
Sum of capacity code of upstream module C <sub>∑</sub>	Gas pipe (mm/inch)	Liquid pipe(mm/inch)
$C \leq 280$	$\Phi 22.2$	$\Phi 9.52$
$280 < C \leq 450$	$\Phi 28.6$	$\Phi 12.7$
$450 < C \leq 670$	$\Phi 28.6$	$\Phi 15.9$
$670 < C \leq 954$	$\Phi 34.9$	$\Phi 19.05$
$950 < C \leq 1350$	$\Phi 41.3$	$\Phi 19.05$
$1350 < C \leq 1600$	$\Phi 44.5$	$\Phi 22.2$
$1600 < C \leq 2100$	$\Phi 54.1$	$\Phi 25.4$

#### 4.5.2.3 Piping used for balancing lubricant

The oil balance pipe is connected by using  $\Phi 12.7$  copper pipe. For three outdoor units arranged in parallel, one 3-way joint having an inner diameter of  $\Phi 12.9$  shall be used in the oil balance pipe.

## 4.6. Outdoor unit piping sequence diagram

### A. GMV-Pdm224W/NaB-M, GMV-Pdm280W/NaB-M

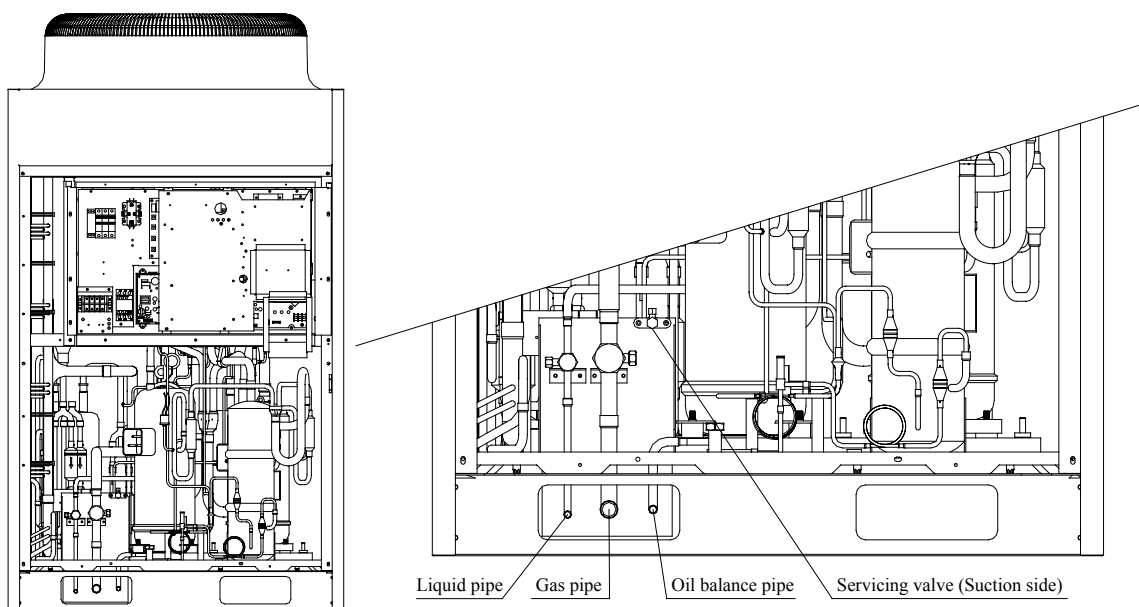

### B. GMV-Pdm335W/NaB-M, GMV-Pdm400W/NaB-M, GMV-Pdm450W/NaB-M

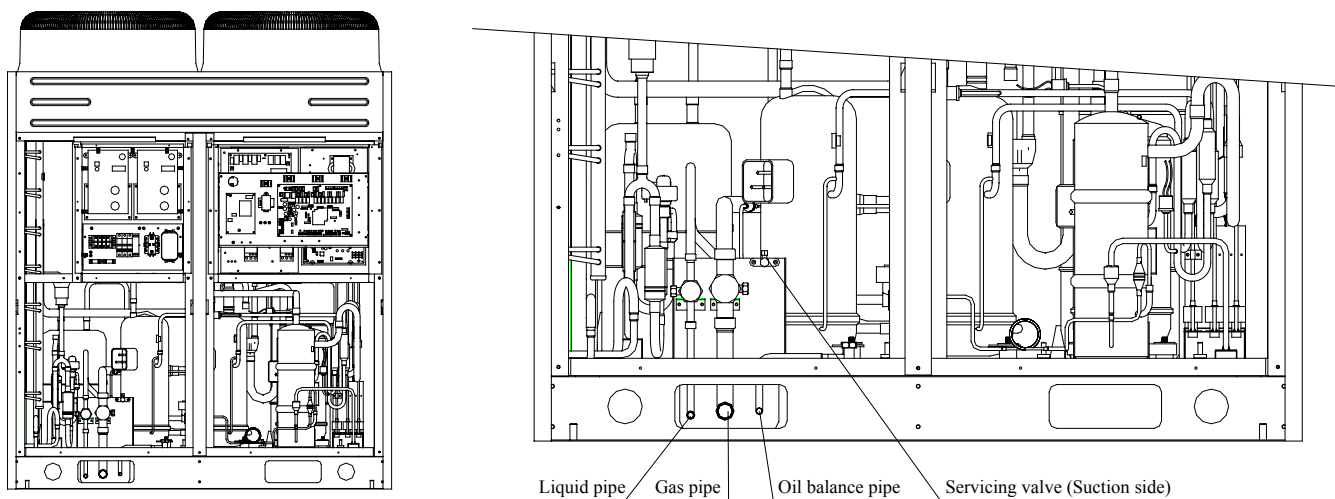

### C. The piping connection diagram of outdoor unit

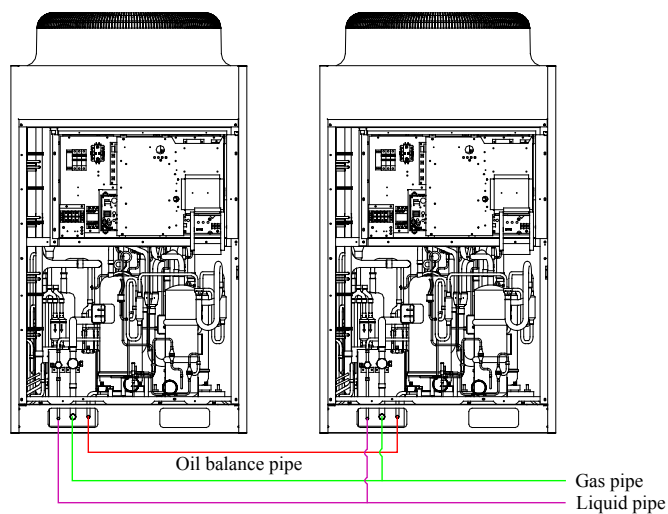

#### 4.7 Design requirements for oil trap

If the height different between the indoor unit and outdoor unit exceeds 6m, one oil trap shall be installed every 6m from lower to upper on the vertical section of gas pipe. The oil trap shall be fabricated into two U-type elbows or one return-type elbow. The height shall be 3~5 times the piping diameter.

See below for details on installation and fabrication of oil trap.

- a. The oil trap may be fabricated into U-type or return-type.
- b. If outdoor unit is below indoor unit, it is not needed to install oil trap on the vertical pipe of gas piping.
- c. If the outdoor unit is below the indoor unit, it is not needed to install oil trap at the highest or lowest position. If the outdoor unit is above the indoor unit, oil trap and stop elbow must be installed at the lowest and highest position of the vertical pipe. See the schematics below:
- d. See the schematics below:

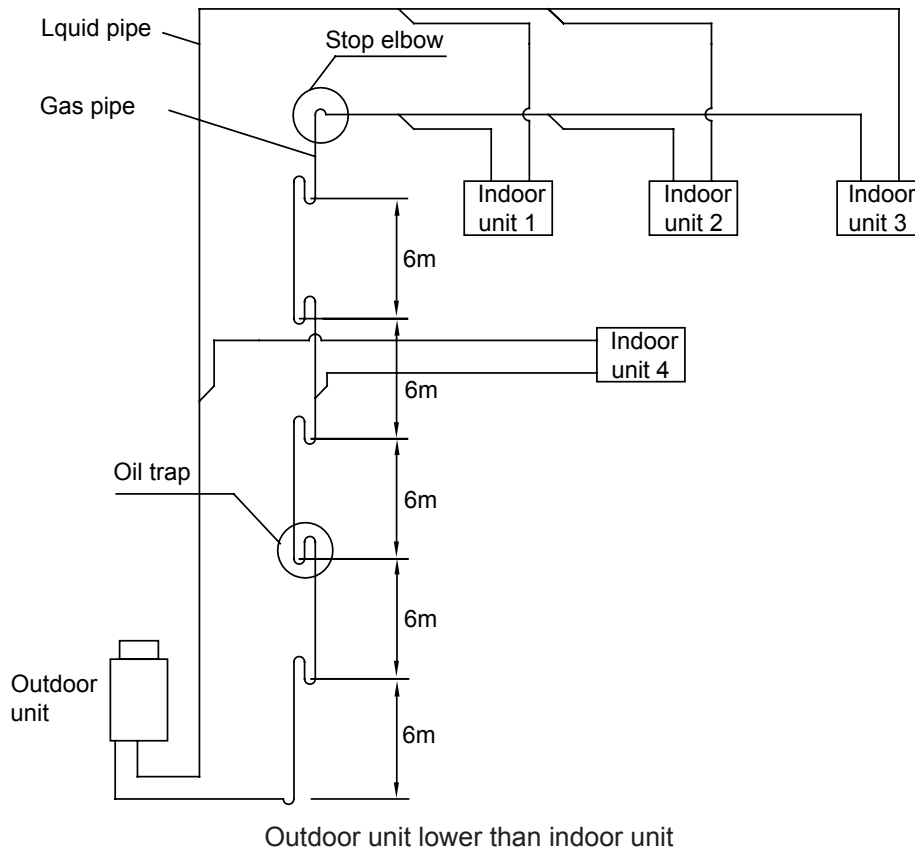

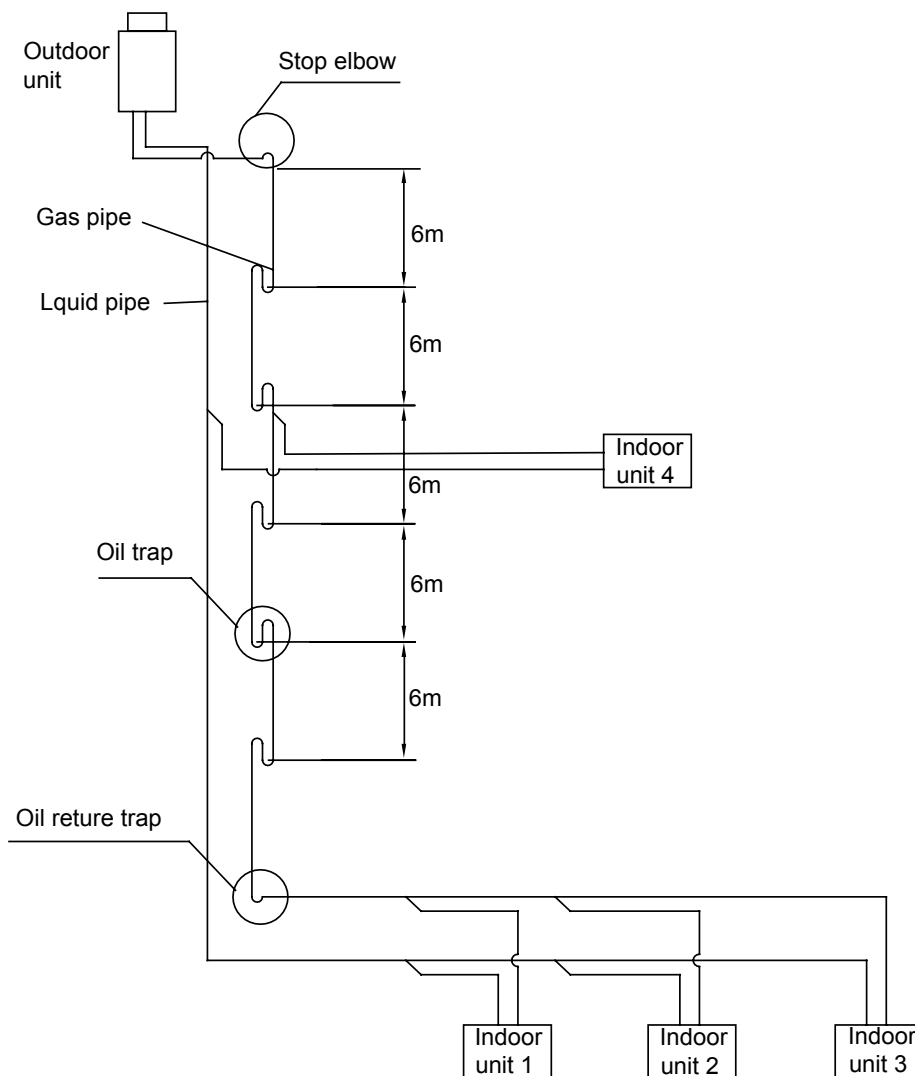

Outdoor unit higher than indoor unit

e. Fabrication dimension of oil trap is as shown below:

A		B(mm)	C(mm)
mm	inch		
Φ19.0	3/4	≥34	≤150
Φ22.2	7/8	≥31	≤150
Φ25.4	1/1	≥45	≤150
Φ28.6	9/8	≥45	≤150
Φ34.9	11/8	≥60	≤250
Φ38.1	12/8	≥60	≤350
Φ41.3	13/8	≥80	≤450
Φ44.45	7/4	≥90	≤500
Φ54.1	17/8	≥90	≤500

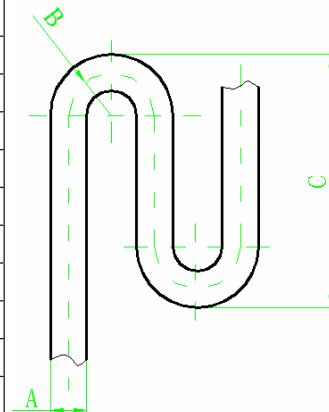

## 5 INSTALLATION OF REFRIGERANT PIPING

### 5.1 Flow Chart of Installation

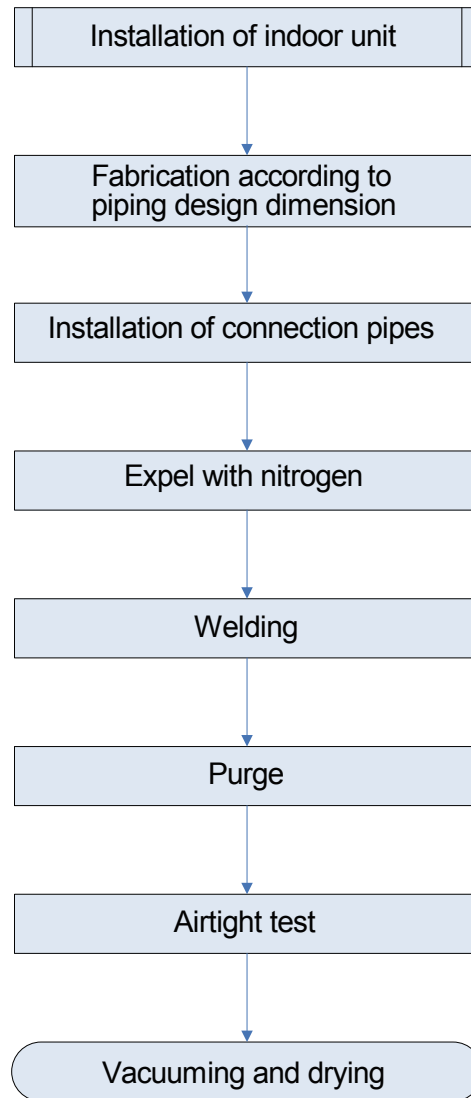

## 5.2 Three Principles of Refrigerant Piping Installation

Observe the three principles of refrigerant piping:

	Key Factors	Measures to Avoid Failure
Dry	Invasion of outside water Example: Rainwater, engineering water Invasion of indoor condensate	<pre> graph LR     A[Fabrication of fitting pipe] --&gt; B[Purge]     B --&gt; C[Vacuuming and drying]             </pre>
Clean	Formation of oxides inside the pipe during welding Invasion of dust and foreign articles from outside	<pre> graph LR     A[Fabrication of fitting pipe] --&gt; B[Expel with nitrogen 0.05~0.3Mpa]     B --&gt; C[Purge]             </pre>
Airtight	Incomplete welding Leakage from flared port Leakage from edge	<pre> graph LR     A[Use suitable materials (copper tube, soldering bar)] --&gt; D[Airtight test]     B[Observe the basic welding procedures] --&gt; D     C[Observe the basic operations for flaring of fitting pipe] --&gt; D     E[Observe the basic interfacting procedures] --&gt; D             </pre>

## 5.3 Installation of Metal Embedded Pipe

### ◆ Work Order

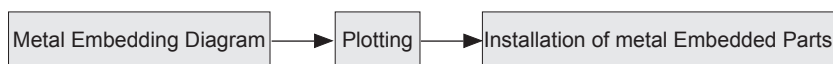

Plot the line on ground if possible and use laser to project it onto the roof. This is quick and correct.

### ◆ Advance Installation of Metal Embedded Parts

Please select according to local codes.

### ◆ Subsequent Installation of Expansion Bolts

In case that the metal embedded parts cannot be used due to design change, the expansion bolts may be used.

### ◆ Subsequent Installation of Expansion Bolts

The foot pedal shall be supported on three points if exceeding 2m.

The foot pedal must be fixed securely to the ladder.

Please do not work on the top of ladder.

## 5.4 Installation of Carriage of Refrigerant pipin

### 5.4.1 Fixing of horizontal pipe

The refrigerant pipe will extend and shrink with each start or stop of the air conditioner unit (5~10 times / hour). Under a temperature difference of 80°C, this extension may reach 13.84mm for every 10m. To prevent failure, the pipes must be reinforced as follows.

Spacing between supports

Outer diameter of pipe (mm)	6.35-8.52	Over 12.7
Spacing between supports (m)	Below 1.2	Below 1.5

### Note:

If the gas pipe and liquid pipe are suspended together, the size of liquid pipe shall prevail

### ⚠ CAUTION

Never make the pipe directly contact with the fixing metal parts. Thermal insulation shall be provided around the fixing metal parts; otherwise, condensing will occur.

#### 5.4.2 Fixing of vertical pipe

The vertical pipe may be fixed by using the commodity tools in market or self-made tools. As above, the fixing point shall also be thermally insulated.

#### 5.4.3 Fixing of other points

Measures shall be taken to prevent the extension or shrinkage of pipes from causing excessive loads to some positions, machine joint and waterproof points. Generally, such positions refer to the branch pipe joint, pipe ends, four sides of indoor unit and wall-cross hole.

### 5.5 Management and Machining of Refrigerant Piping

#### 5.5.1 Storage

◆ After receiving the refrigerant pipe and other components, do not move them to the storage until confirming that they have no deformation, bend, crack or damage.

◆ The pipe end must be sealed to prevent the invasion of moisture or wastes.

◆ The copper pipe with coating may become deformed under the compression of the coating material, so that the coils shall be placed upright.

◆ To avoid the invasion of moisture or wastes, a support higher than the ground must be built by using woods.

◆ Care of pipe end during construction

The pipe ends must be well cared during construction. According to the working position, work progress and surrounding environment, the most effective way is to seal the end and wrap with adhesive tape.

##### 1) Sealing method

Clamp the pipe end and weld on it

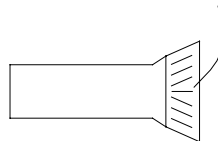

Clamp the pipe end to flat and weld on the clearance. Then, charge nitrogen 2~5kgf/cm<sup>2</sup>. This will be more effective.

##### 2) Method for wrapping with adhesive tape

Seal the pipe end with ethylene tape.

#### 5.5.2 Unwinding the coil



#### CAUTION

⑥. When unwinding the coil, take care not to drag it on the ground. The coil shall be slowly unwound on ground without any twisting. In case of excessive compression by any hard object during unwinding, the thermal insulation materials may be damaged and cannot be recovered, which will deteriorate the performance of thermal insulation. Do not unwind carelessly. Otherwise, the fitting pipe might be flattened.

⑦. The copper pipe shall be rounded if the pipe end is deformed

The higher the size, the higher the possible deformation.

### 5.5.3 Measuring

◆ (To reduce the resistance and length of copper pipe), the dimension of main refrigerant pipe shall be so taken that the bends shall be minimized, the radius of bend section shall be increased and the upstream and downstream section shall be reduced. Use the method that can reduce the actual length and equivalent length of the copper pipe.

◆ Sometimes the connection pipe of indoor unit must be adjusted due to the relation with accessories, drainage pipe and connection surface. Therefore, a fairly marginal dimension shall be taken.

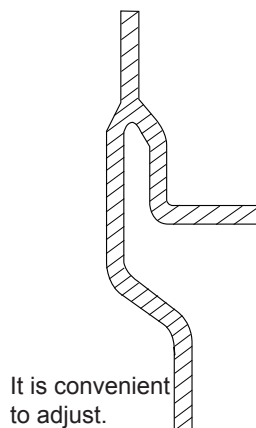

### 5.5.4 Cut-Chamfer

#### ◆ Cut

a. Cut vertically to axis direction by using special pipe cutter that is suitable to the dimension of copper pipe (big, medium, small).

b. During operation, press and rotate the pipe cutter slowly and cut off the copper pipe without causing any deformation.

Never use saw or grinding wheel, because the copper scraps may be left inside the pipe. Even use of such tools once will make all works scrapped. It is useless no matter how good the quality of other works. It is best that all operators shall have one pipe cutter and at least one pipe cutter of big dimension shall be provided on site.



#### **CAUTION**

To prevent the invasion of water or waste, avoid placing the copper pipe directly on ground.

#### ◆ Chamfer

Burrs may occur on the cutting face of copper pipe and must be removed. Meanwhile, purge the foreign articles out of the pipe and refinish the pipe end.

- Use scraper or other tools to remove the burrs on inner side.

(To prevent copper scraps from falling into the pipe, please keep the pipe end downward during operation).

- If the pipe end is obviously deformed, please cut and throw it off, and then refinish the pipe end.
- Eliminate the copper scraps thoroughly, and use cotton yarn to wipe the pipe clean.

※ The flared joint must be kept smooth.

※ When removing the burrs with scraper, do not remove too much, especially for the fitting pipe of small diameter; otherwise the contact surface of the flared joint will be reduced. Do not cause any scores, and avoid cracking after the flared joint is formed.

※ Adverse impact if the burrs are removed too much with scraper.



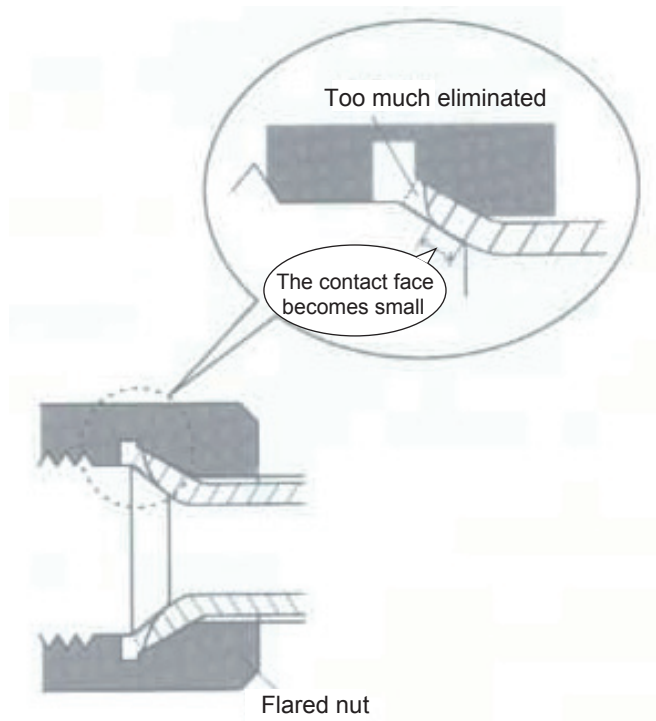

### 5.5.5 Pipe bending

◆ Work Methods

- a. Bend by hand .....Suitable to fine copper pipe ( $\phi 6.35\text{mm}-\phi 12.7\text{mm}$ ).
- b. Machining with spring pipe bender ..... Bend by inserting the spring into copper pipe or sheathing onto the copper pipe ( $\phi 6.35\text{mm}-\phi 22.2\text{mm}$ ).
- c. Machining with hand-operated pipe bender.....Use the pipe bender of suitable dimension ( $\phi 6.35\text{mm}-\phi 22.2\text{mm}$ ).
- d. Machining with electric pipe bender (hydraulic).....Suitable for mass machining of fine and coarse fitting pipes ( $\phi 6.35\text{mm}-\phi 69.9\text{mm}$ ).

**Advantage**

※ Decrease the weld joint, thus reduce the possibility of leakage and oxidization.

For example:

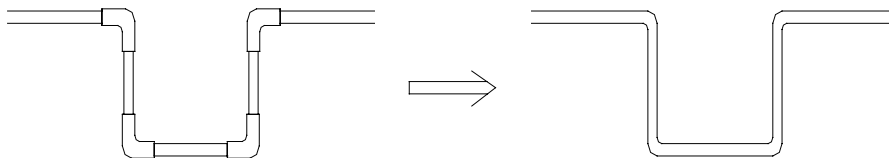

It can decrease the weld by 8 spots. Please act now to improve the quality.

- ※ No joint is required, which will save the material costs. Reduced waste of fitting pipe materials.
- ※ Reduced resistance in the fitting pipe. The bending radius higher than the pipe joint.

◆ **Cautions:**

- ※ During bending, there shall be no wrinkling or deformation on the inner side of the copper pipe.
- ※ Spring pipe bend
- ※ The bender inserted into the copper pipe must be cleaned.
- ※ Do not bend over  $90^\circ$ . (Otherwise, wrinkling may be formed on the inner side of copper pipe and in the future, the copper pipe will be broken from this position.)

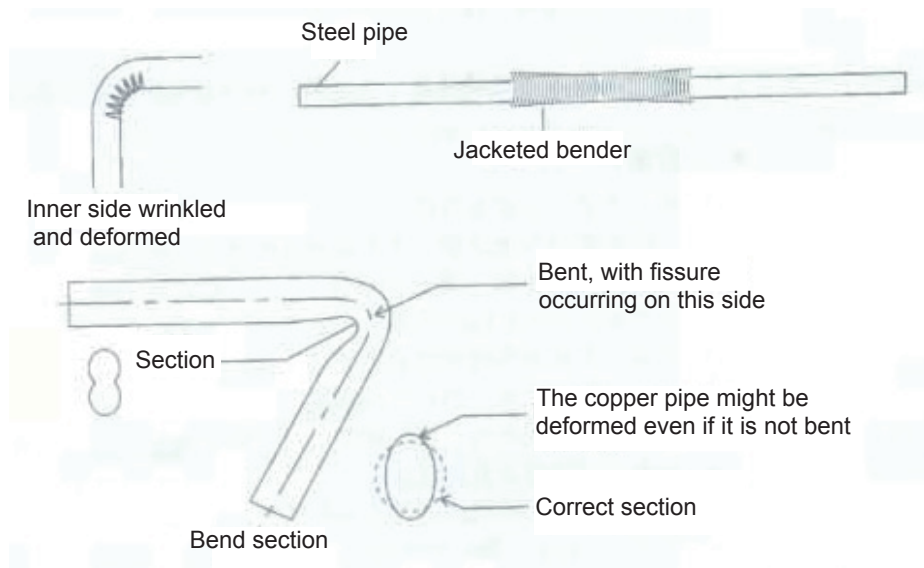

### 5.5.6 Flaring

The flaring refers to expansion of pipe opening. The copper pipe is inserted here to replace the casing pipe. In this way, it is only needed to weld on one position where the pipe is expanded.

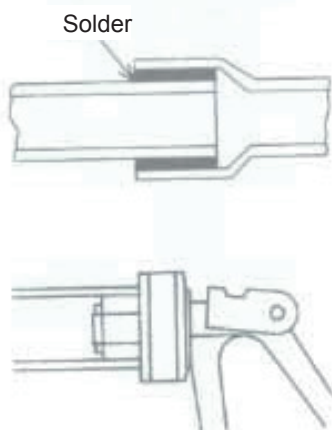

## 5.6 Installation of Refrigerant Piping

### 5.6.1 Precautions on piping works

◆ At the site of transport, storage and construction, the two ends of copper pipes shall be sealed with plastic sealing caps. Before welding, copper pipes must be cleaned (washing the inner side of pipe with alcohol) to ensure no dust and no water in pipeline

◆ Nitrogen-filled welding shall be used for the welding of copper pipes. Nitrogen pressure shall be  $0.5 \pm 0.1 \text{ kgf/cm}^2$ . Nitrogen flow can be sensed by hand.

◆ When multiple multi-connected units are installed, refrigerant piping must be marked to avoid confusion between pipes of different units.

◆ A two-way drier shall be mounted at the liquid pipe side at the place where an outdoor unit is connected.

### 5.6.2 Assemble copper pipes

The copper pipe shall be vertically inserted to the specified length. The centerline of two assemblies shall overlap. The position shall be determined for welding. To ensure correct mounting size, do not determine the position with your hands, thus to prevent the copper pipe from moving when heated.

See below for the welding size of copper pipe:

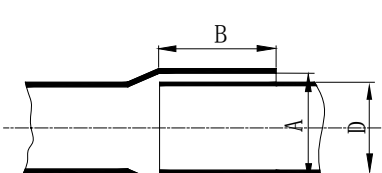
	Outer diameter of pipe D(mm)	Minimum depth of penetration B(mm)	Clearance between pipes A-D
	$\phi 6.35$	6	0.05~0.21
$\phi 9.52, \phi 12.7$	7		
$\phi 15.8$	8	0.05~0.27	
$\phi 19.05, \phi 22.2, \phi 25.4$	10		
$\phi 28.6, \phi 31.8$	12	0.05~0.35	
$\geq \phi 35$	14		

If the mounting clearance is too large, the diameter of coarse pipe may be reduced to an appropriate value to according to applicable specifications, if any.

### 5.6.3 Installation of branch pipe

◆ The branch pipe plays the function to divert the refrigerant flow. Therefore, the selection and installation of branch pipe is very important to the operation of multi-unit. Based on correct selection of branch pipe, the branch pipe must be installed according to installation specifications.

◆ Connection schematics for Y-type branch pipe

The connection of Y-type branch pipe is as shown below. The inlet is connected to outdoor unit or previous branch; the outlet is connected to indoor unit or next branch.

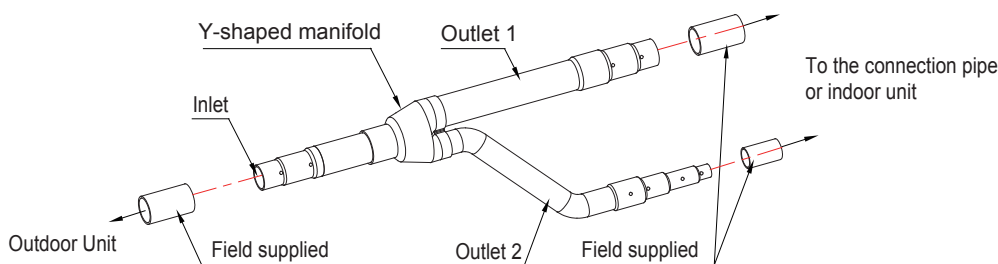

◆ Installation specifications for branch pipe

Placement of branch pipe

The branch pipe can only be placed horizontally. Meanwhile, two branch pipes must be on the same plane. The spacing between two branch pipes must be over 800mm, the spacing between two bends must be over 800mm, and the spacing between branch pipe and bend point must also be over 800mm.

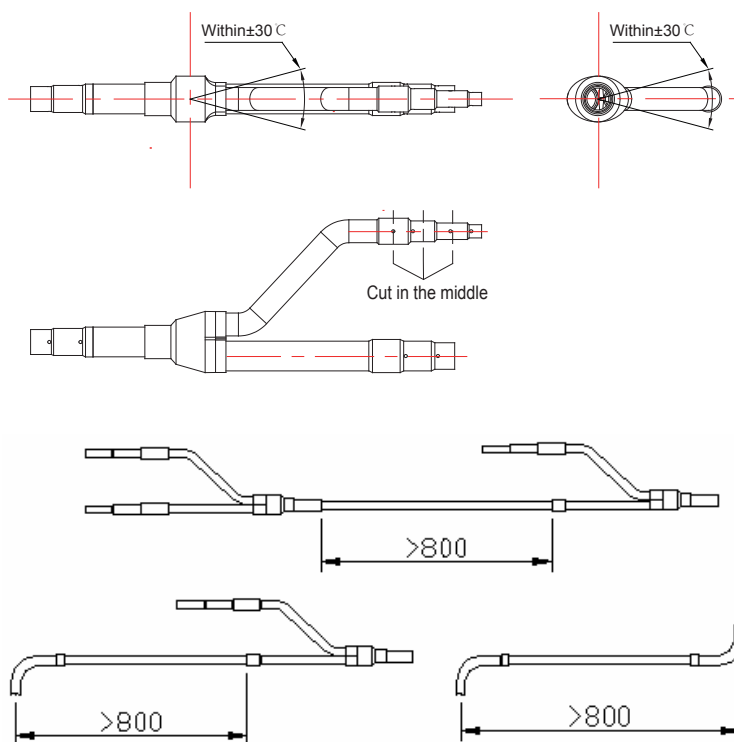

### Connection of branch pipe

The Y-type branch pipe is installed with additional tube. The purpose is to adjust the different pipe diameters. If the pipe size selected on site is different from the size of branch connector, please use the pipe cutter to cut from the middle of different connection pipes and remove the burrs. Then, insert the copper pipe to appropriate depth. The branch pipes from Gree are all provided with positioning mark.

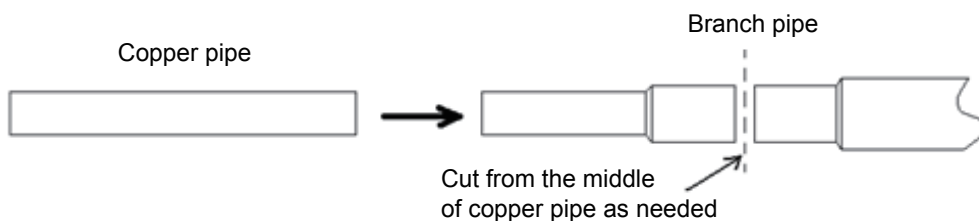

Do not use the connection method that the copper pipe is cased on branch pipe of smaller diameter.

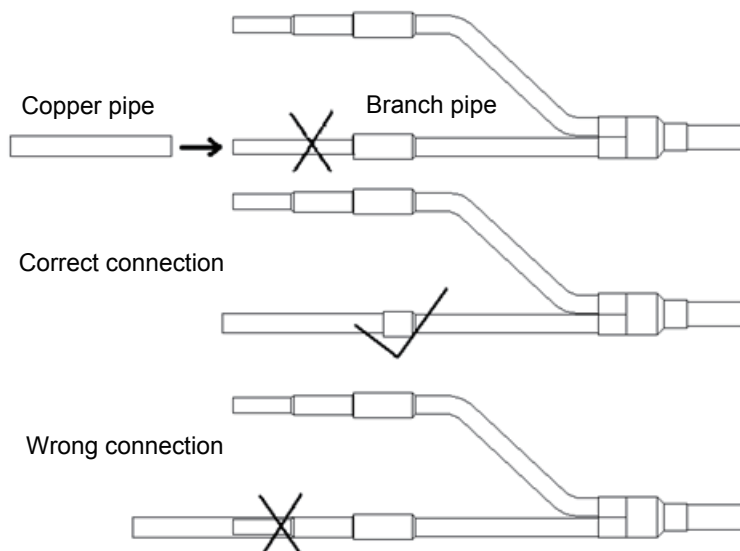

The copper pipe shall not be inserted into the branch pipe too deep.

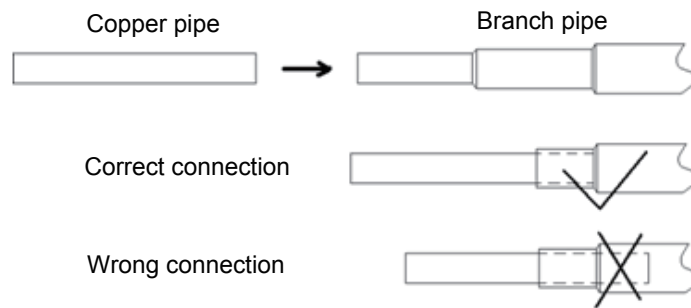

## 5.7 Welding of Copper Pipe

### 5.7.1 Braze welding

#### Materials for braze welding

There are two kinds of braze welding, soft braze welding and hard braze welding. Hard braze welding is required in this case.

#### Selection of braze welding

Red copper + red copper: brazing filler metal is Bcu93P(GB 6418), and welding flux is not needed.

Flame flux: capable of preventing the surface of copper pipes from oxidation, recommended for use.

Temperature for braze welding: 820-860 °C (copper pipe becomes light red)

### 5.7.2 Safety acknowledgement before operation

- Roll calling of construction personnel and confirmation on their health status.
- Acknowledgement on work suits (helmets, clothes, safety bags and safety shoes)
- Description of work location and environment.
- Job division shall be made. Job content, method and order shall be indicated. Risk prediction activities shall be performed.
- “Construction Schedule” shall be worked out.
- Head of each group shall be assigned
- Risks of occurrence of an accident such as electric shock or fire shall be indicated.
- Instructions on how to use electric machinery properly shall be available.
- Locations marked with “Staff Only” shall be indicated.
- An application is necessary for use of open flame and shall be reviewed by on-site safety officer for approval.
- Instructions given by fire authorities shall be accepted in accordance with local laws and regulations.
- Tools shall be sorted and counted. Upon knocking off for the day, tools shall be sorted and counted. If necessary, the piping system shall be charged with coolant to avoid exhaustion.

### 6.7.3 Attention

- Construction personnel must have relevant operation qualification.  
Flame operation must be undertaken by qualified persons in accordance with local laws and regulations.
- Wear coveralls (cotton for the best), safety shoes, safety helmet, leather gloves, protective goggles and anti-dust mask.  
Welding torch with back fire arrestor shall be used to ensure safety.
- Take care not to be burned by flame and heating parts.
- Gas cylinder shall be handled carefully to prevent leakage.
- Combustible substances in the surrounding areas shall be moved away. If movement is impossible, fire proofing treatment shall be taken properly, such as being covered by flame-proof enclosure.
- Good ventilation is necessary to avoid breathe in of harmful gas.
- Appropriate measures shall be taken if there is a safety problem.
- Operation on connectors of branch pipes as well as on the surrounding of pipe ends shall be performed on the ground as possible, because heating is difficult to control at a high place and welded part of a branch

pipe is prone to be melted to cause leakage.

For example:

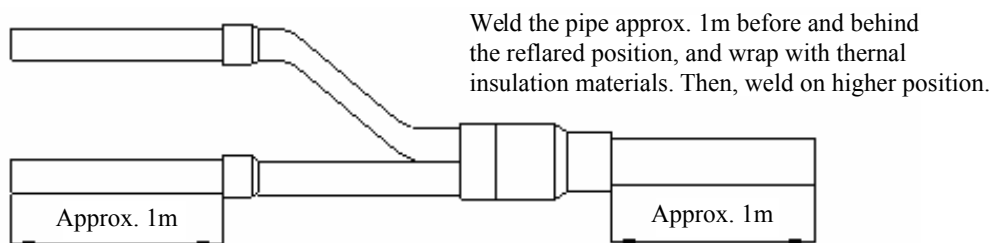

i. To avoid the position difficult to weld, you may add a prefabricated assembly below.

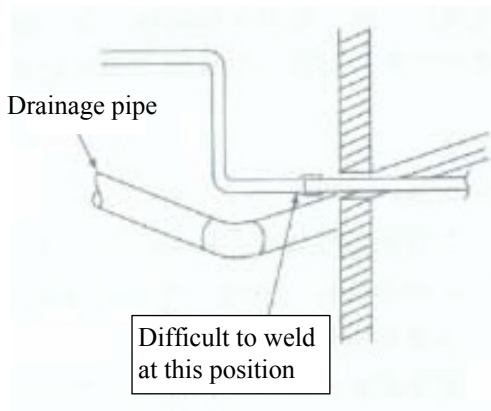

#### 5.7.4 Operation order

Basic procedures for welding:

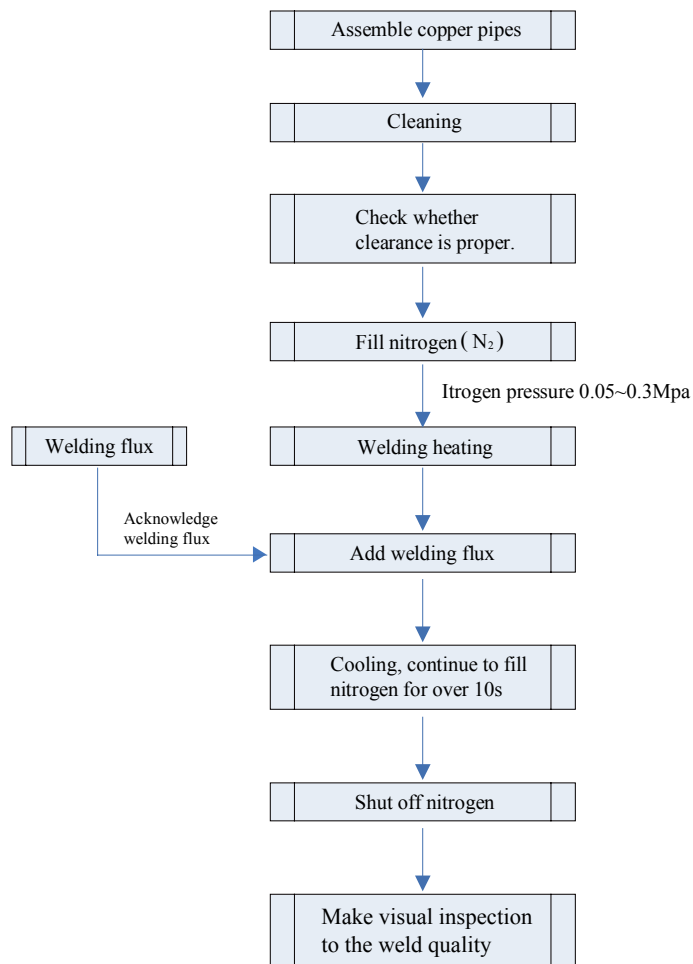

a. Cleaning of portions for braze welding

Polishing.....Removing metal materials at connection portion. (Removing oxidation film using non-woven fabric, abrasive cloth or abrasive paper)

Ungrease.....If any oil stain is existent, acetone or spirit solvent shall be used for ungrease treatment.

At the same time, compressed air at 0.8MPa (gauge pressure) shall be used for cleaning The cleaning shall be repeated not less than 3 times, until there is no dirt discharged.

b. Check whether clearance between pipe and connector is proper.

Put the connector into the pipe and face downward. If the connector does not fall down depending on friction force, the clearance is considered proper.

c. Nitrogen-filled protection

● Since vigorous oxidation would occur on the surface of copper pipe at braze welding temperature, to effectively restrain the generation of oxide coating in copper pipe, nitrogen-filled protection for copper pipe is necessary.

- After copper pipes are assembled, nitrogen shall be filled in copper pipe connectors
- Method for charging nitrogen into copper pipe

**Nitrogen charging method:**

Pressure is  $0.5 \pm 0.1 \text{ kgf/cm}^2$ . Nitrogen flow of 4~6L/min (gas flow can be sensed by hand) shall be guaranteed to charge in work pieces.

After assembling, nitrogen begins to charge until welding is finished and will continue over 10s during cooling after welding.

※ Main points of nitrogen charge(See the drawing below)

◆ When nitrogen is charged, the press switch on the quick connector and inflator shall be closed to let nitrogen totally filled in the pipe.

◆ Make sure nitrogen reaches all welding connectors in order to effectively discharge air

◆ A vent port must be available when nitrogen charge is continuously performed, or otherwise gas would escape from gap around connector, making welding stuffing difficult and prone to pores.

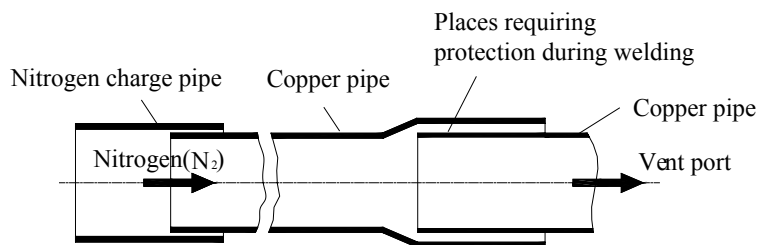

d. Welding heating

Notes:

- Braze welding is flame hard braze welding. Relevant safety operating regulations must be abided by.
- Confirm that nitrogen is flowing through before copper pipe is heated.
- Neutral flame or slightly reducing flame shall be used for red copper braze welding. Outer flame is normally used. Copper pipe connectors shall be heated uniformly. Take care to distribute heat in terms of dimension of pipe material. Generally, insert pipe shall be preheated at first for close matching and then swayed along length of connector to make it heated uniformly until braze welding temperature is approached; then copper pipe is heated circularly to reach braze welding temperature (copper pipe becomes light red) and at the same time brazing filler metal is added circularly to fill in the clearance around the connector uniformly; and afterwards, the welding torch is slowly moved away from the pipe and a small amount of brazing filler metal continues to be filled in until smooth fillet is formed.

- During heating, welding rod shall not be burned directly by flame. Heating time shall not be very long.
- During welding, flame shall be controlled well on its direction and kept away from rubber casing, sponge and cables.

e. Post-welding treatment(cooling)

- After welding, in the condition of nitrogen protection available, the connector shall be heated until the

copper pipe changes color (200-300°C), i.e. annealing treatment.

- Before welding seam becomes completely solidified, welded pieces shall not be moved or shocked.
- For welded piece cooled by water, take care not to let water enter into copper pipe and try to prevent residue water flowing into the pipe when welded piece is laid aside.

f. Quality and inspection of braze welding

Welding seam should have smooth surface. Fillet should be even and full with natural arc transition. Braze welding connector should be free from defects such as over-burning, welding blockage, crack, rough surface of welding seam and burning through. Welding seam should be free from defects such as pore, slag inclusion, underfill, rosin joint and overlap.

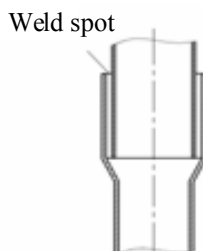

### 5.7.5 Others

- ◆ When braze welding is to be performed underneath, a simple support shall be built, such as two ladders.

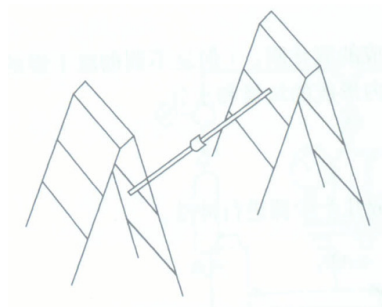



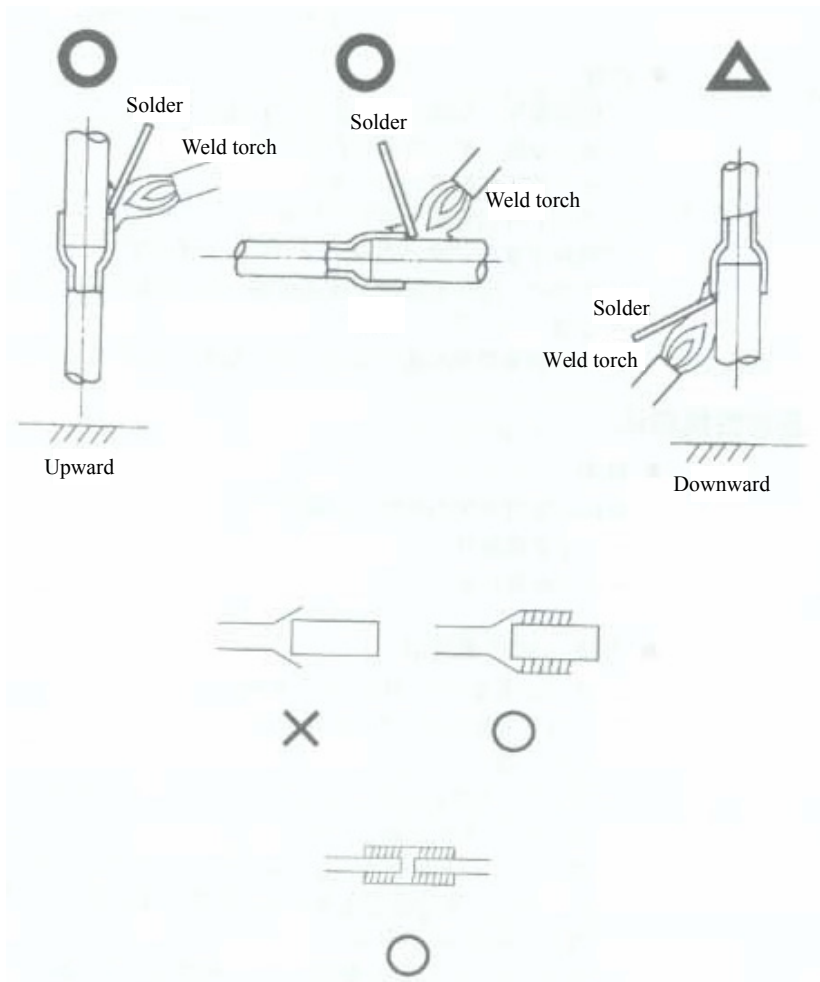

◆ Cooling

o avoid getting a burn in following processes, common wet cloth (humidity content is low, meaning that there shall not be water drips when welded part is cooled; and because shrinkage factor of copper is different from that of welding material, too quick cooling that would cause cracking of braze welding shall be avoided) can be used for cooling welded parts.

- ◆ The following items shall be checked after welding is completed
  - Is there any pore or hole on welded part?
  - Is there evident “sagging of brazing filler metal”?

**5.8 Cleaning of Refrigerant Piping**

After a section of pipeline is welded, cleaning of piping is necessary.

Nitrogen pressure is utilized to remove foreign matters (such as dust, water and beryllium oxide caused by welding) in the piping.

5.8.1 Main purposes of cleaning are as follows

- ◆ To eliminate oxide caused by insufficiency of nitrogen-filled protection during pipe welding.
- ◆ To remove foreign substances and water that may enter the piping due to improper storage and transport.
- ◆ To check whether big leakage is existent at connections of the piping between indoor unit and outdoor unit

5.8.2 Cleaning steps:

- a. Mount a pressure gauge on nitrogen cylinder;

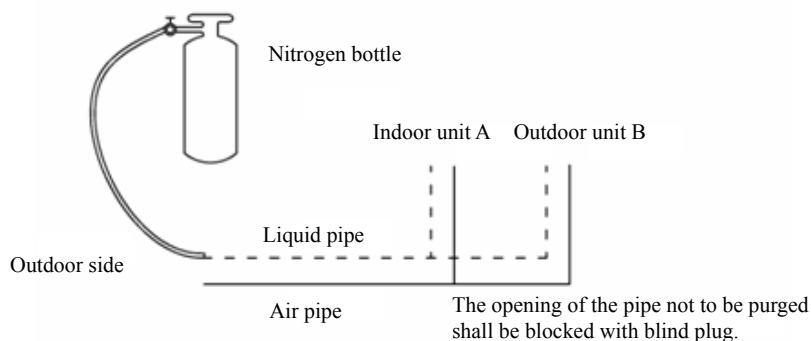

b. High pressure end of the pressure gauge is connected to the refrigerant filling nozzle of the small pipe (liquid pipe).

c. All copper pipe ports outside the A side of indoor unit shall be blocked by blanking plugs

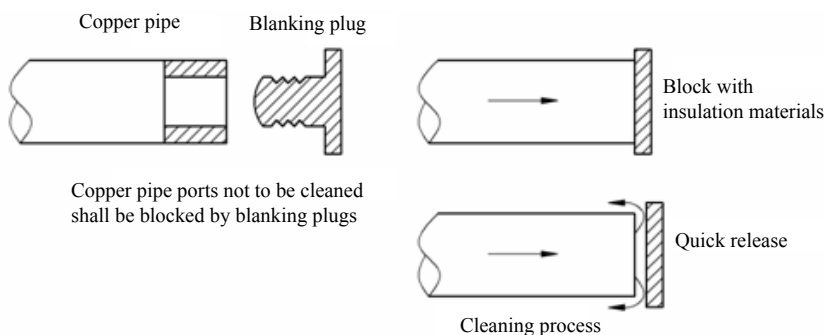

d. The valve on nitrogen cylinder shall be opened to maintain pressure at 28Kgf/ cm<sup>2</sup>

e. Check whether nitrogen flows through the liquid pipe of indoor unit A

f. Cleaning

The mouth of the pipe shall be blocked with insulation material held by hand until pressure rises to a level difficult to be withstood, and at the moment the insulation material shall be released quickly. And then the mouth shall be blocked again. Repeat such procedures several times. Afterwards, use a wood board posted with white paper to check it. If there is not evident dirt on the white paper, the pipe will be considered clean.

g. Shut off the main valve of nitrogen

h. Repeat the above procedures on indoor unit B

i. After cleaning of liquid pipe, gas pipe shall be cleaned in the same way.

## 5.9 Pressure Maintaining and Leak Hunting

### 5.9.1 Pressure maintaining of refrigerant piping

After refrigerant piping of a system is welded,

◆ A refrigerant filling nozzle shall be welded respectively on the big pipe and on the small pipe on the outdoor unit side.

◆ Pipes connected to the end of indoor unit and outdoor unit shall be clamped to be flat and welded to be sealed.

Enter into the step of connection pipe pressure keeping and leak hunting

#### Operating Steps:

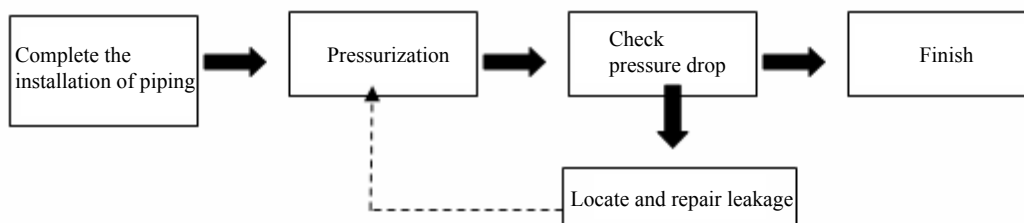

◆ Pressurization

Use nitrogen to add pressure from Freon nozzle of the gas and liquid pipe on outdoor unit side:

Step 1: Increase the pressure to 0.3MPa and wait for 3 minutes or longer

Step 2: Increase the pressure to 1.5MPa and wait for 3 minutes or longer

The step 1 and 2 are focused on checking the significant leakage point. If any, reweld immediately or repair the leakage point.

Step 3: Increase the pressure to 2.5MPa and keep it for approx. 24 hours to check the small leakage.

Though the pressure is increased to 2.5MPa, it cannot be guaranteed to find out the small leakage if the waiting time is too short. Therefore, the pressure in Step 3 must be kept for 24 hours.

Note: During pressure maintaining after nitrogen is filled, the pressure gauge shall not be dismantled, because activities of dismantling or mounting pressure gauge would affect pressure change

◆ Check pressure drop

**Criteria for Inspection eligibility:**

※ Except for temperature influences (pressure changes about 0.01MPa for temperature change of 1°C), if pressure drop is not more than 0.02MPa within 24h, the system will be eligible.

For example, nitrogen is filled to reach 2.5MPa at 30°C; after 24 hours, when temperature becomes 25°C, the system will be eligible if pressure is over 2.43 MPa and ineligible below 2.43 MPa.

※ If ineligible, leak sources must be located. After leak sources are found, re-welding or repair welding is necessary. Then, the above procedures shall be repeated. Nitrogen is filled, pressurized and maintained until pressure drop remains within required range.

◆ Leak check

[Check 1] When pressure drop is found, leak hunting shall be performed in the ways as follows:

- a. By ears.....to listen voices related to leakage
- b. By hands.....to sense whether leakage is existent at connecting parts

[Check 2] If no leakage is found using the above methods, nitrogen shall be discharged and refrigerant shall be filled in to reach 0.5MPa

- a. By soap and water.....soap bubbles will show leakage positions if any.
- b. Detector (such as halide detector) can be used for leak hunting.

Using the above methods, check all possible leak sources.

If leakage still fails to be located, sectional check shall be taken for refrigerant piping that would be divided into multiple check portions for locating leak source in a certain section.

### 5.9.2 Pressure maintaining and leak hunting of the system(with refrigerant piping in connection with indoor unit and outdoor unit)

When refrigerant piping is to be installed, pressure maintaining and leak hunting is required for the piping. After refrigerant piping is in connection with indoor unit and outdoor unit, pressure maintaining and leak hunting is also required. The purpose of the test is to check whether any leak is existent at threaded connection of indoor unit and outdoor unit and at new welded points.

Steps:

◆ Nitrogen is charged to reach 2.5MPa and remains at the pressure for 24h (nitrogen shall be filled from refrigerant filling nozzles at the big valve as well as the small valve using a pressure gauge; during pressure maintaining after nitrogen is charged, the pressure gauge shall not be dismantled.)

◆ Observe whether pressure changes in 24 hours. (for eligibility criteria, see pressure maintaining and leak hunting of refrigerant piping in 5.5.2)

◆ If any leakage, please check threaded connections and new welded spots of indoor unit and outdoor unit. Repair welding shall be performed immediately. Afterwards, pressure maintaining is repeated until eligibility is reached.

### 5.9.3 Cautions

- a. The pressure meter range of R410A system should be more than 4.5MPa.
- b. Record the pressure, ambient temperature and testing hours.
- c. Pressure modification: when the temperature changes for 1 °C, the pressure will change for 0.01MPa.
- d. The pressure should be stable.
- e. If it is necessary to retain the pressure, the pressure should be decreased to 0.5MPa or below. The long-time high pressure may lead to leak of soldering spot, which may cause safety problem.
- f. Before completion of airtight test for refrigerant pipe, do not wrap the soldering spot or horn mouth connecting spot. During pressurizing, pressurize the outdoor side pipe at the same time instead of pressurizing only one side pipe.

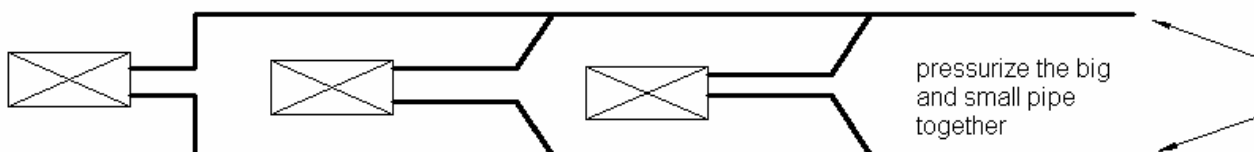

Note: Before completion of airtight test for refrigerant pipe, do not wrap the soldering spot.

## 5.10 Heat Preservation of Refrigerant Piping

### 5.10.1 Connection of thermal insulation pipe

Carry out thermal insulation to the refrigerant pipe after confirming that it has no leakage.

Please perform thermal insulation to the refrigerant pipe according to the steps below:

- ◆ Check if the thermal insulation pipe has met the thickness requirements. If not, the condensing water is easy to attach on thermal insulation pipe and finally drips. The thickness requirements are shown below:

Refrigerant Pipe (mm) (Outer Dia. x Thickness)	Thickness of Thermal Insulation Materials (mm)
Φ6.35×0.5	≥10
Φ9.52×0.71	≥10
Φ12.7×1	≥15
Φ15.9×1	≥15
Φ19.05×1	≥15
Φ22.2×1.5	≥20
Φ25.4×1.5	≥20
Φ28.6×1.5	≥20
Φ34.9×1.5	≥20

- ◆ Wrap the refrigerant pipe according to required thickness. The clearance between thermal insulation pipes shall be sealed with self-adhesive sticker.

- ◆ Wrap the thermal insulation pipes with tapes, thus to extend their ageing time

### 5.10.2 Cautions:

The thermal insulation materials shall be able to withstand the pipe temperature. For heat pump unit, it is required to withstand a temperature not lower than 70°C on liquid pipe side and not lower than 120°C on gas pipe side. For cooling-only unit, it is required to withstand a temperature not lower than 70°C on both liquid pipe side and gas pipe side.

Example: Heat resistant PVC foam (over 120°C); Foam PVC (over 100°C)

- ◆ The connector between indoor unit and outdoor unit shall be wrapped with thermal insulation materials, and shall have no clearance to the wall on which the outdoor unit is mounted, as shown below.

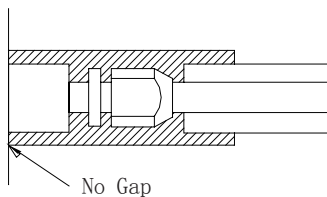

◆ When wrapping the thermal insulation tape, each circle shall suppress half of the previous circle. To avoid reducing the thermal isolation effect, do not wrap the tapes too tight.

◆ After completing the protection work and wrapping the pipes, use the sealing materials to block the holes in the wall.

## 5.11 Vacuum Pumping

### 5.11.1 Purposes of vacuum pumping

- ◆ Discharge air and nitrogen in the piping to obtain vacuum state.
- ◆ Vacuum is dry, capable to remove moisture in the system.

Under atmospheric pressure, the boiling point of water is 100°C. But with increased vacuum degree created by vacuum pump, the boiling point rapidly reduces. If boiling point reduces below ambient temperature, moisture in piping will be evaporated. If vacuum is 0Kgf/cm<sup>2</sup> of absolute pressure (gauge pressure is -1Kgf/cm<sup>2</sup>), moisture in the system can be evaporated totally

### 5.11.2 Selection of vacuum pump

Proper vacuum pumps must be selected before vacuum pumping. Insufficient capacity of selected vacuum pump would lead to overtime of vacuum pumping and fall short of the requirement for vacuum degree. A proper vacuum pump can obtain vacuum degree of 0Kgf/cm<sup>2</sup> (gauge pressure -1 Kgf/cm<sup>2</sup>) after vacuum pumping.

- ◆ Features of a vacuum pump shall be determined by two factors as follows:
- ◆ Selection of a pump that can meet expected requirement (i.e. gauge pressure of -0.1MPa shall be obtained)

Exhaust flow is high (over 40L/min).

The following vacuum pumps are recommended

Model	Maximum vacuum air displacement	Use	
		Air discharge	Vacuum drying
Lubricant shaft pump	100L/min	Suitable	Suitable
Non-lubricant shaft pump	50L/min	Suitable	Suitable

Comparison table of different pressure units is as follows:

	Unit	Standard air pressure	Vacuum degree
Relative pressure	kg/cm <sup>2</sup>	0	-1.033
Absolute pressure	kg/cm <sup>2</sup>	1.033	0
mmHg	mmHg	0	-755

### 5.11.3 Vacuum pumping

**The steps are as follows:**

- a. Expel the nitrogen after leakage detection;

Connect the pressure gauge to Freon nozzle on outdoor liquid valve and gas valve, and connect a vacuum pump. Then, establish vacuum simultaneously from high pressure side and low pressure side.

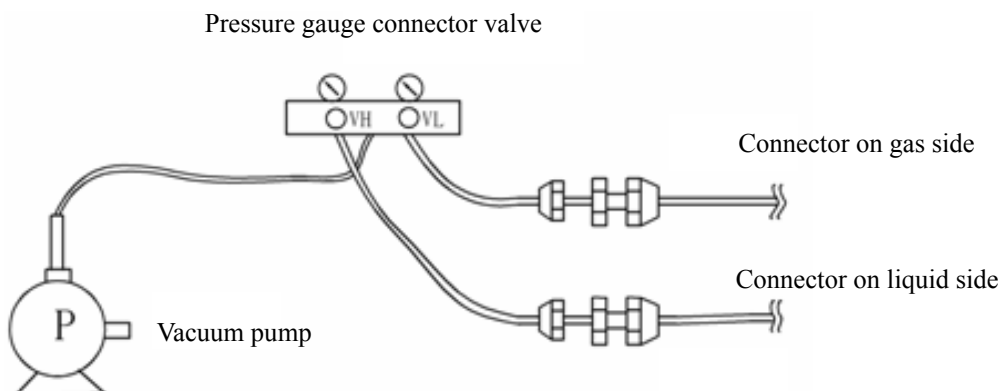

Start the vacuum pump and turn on “LO” and “HI” knobs;

b. Continue for 0.5~1.0 hour after the vacuum level reaches -0.1MPa (gauge pressure -1kgf/cm<sup>2</sup>). Then, close the “VH” knob on high pressure end and “VL” knob on low pressure end to stop the vacuum pump.

c. Remove the hose connected to vacuum pump and reconnect it to the refrigerant tank. Expel the air in the hose. Open the “VL” knob on low pressure end to charge refrigerant to the system piping. When the pressure reaches 0.0kgf/cm<sup>2</sup>, close the “VL” knob on low pressure end.

d. Remove the hose connected to refrigerant tank and reconnect it to vacuum pump. Start the vacuum pump and open the “VH” knob on high pressure end. Pump for 30 minutes from high pressure end and then open the “VL” knob to pump from low pressure end, until the vacuum level reaches -0.1MPa (gauge pressure -1kgf/cm<sup>2</sup>).

If the vacuum level reaches -0.1MPa (gauge pressure) or lower, the vacuuming process is then ended. Stop the vacuum pump and place still for 1 hour. Then, check the vacuum level for any change. In case of any change, it indicates that there is leakage. In this case, proceed to leakage detection and repair.

- e. When the procedures for vacuum pumping are finished, refrigerant shall be charged.

## 5.12 Refrigerant Charge

### 5.12.1 Calculation method for refrigerant charging

Refrigerant shall be charged according to calculated amount specified in engineering drawings.

Method for calculation of added refrigerant volume (based on liquid pipe)

Mass of refrigerant to be charged = ∑ length of liquid pipe × refrigerant charge amount of every meter of liquid pipe.

Amount of refrigerant charge for every meter of liquid pipe(kg/m)					
Φ22.2	Φ19.05	Φ15.9	Φ12.7	Φ9.52	Φ6.35
0.35	0.25	0.17	0.11	0.054	0.022

**Note:**

a. Standard pipe length is 15m. If refrigerant piping (L) is shorter than or equal to 15m, no additional refrigerant is needed. If piping is longer than 15m (based on liquid pipe), more refrigerant shall be added. The above table shows how much refrigerant shall be charged for every one additional meter of piping.

- b. Electronic balance shall be used for refrigerant charge.
- c. Thickness of pipe wall shall be 0.5~1.0mm and pressure-bearing capability shall be 3.0MPa.
- d. The longer the piping, the more refrigerating capacity and heating capacity shall be weakened.

5.12.2 Steps of refrigerant charge are as follows:

a. The connecting hose of refrigerant cylinder shall be connected to the connector of the pressure gauge. The valve VH shall be opened to discharge air in the hose. Then, the high pressure end of the pressure gauge shall be connected to the refrigerant filling nozzle on the small valve of outdoor unit.

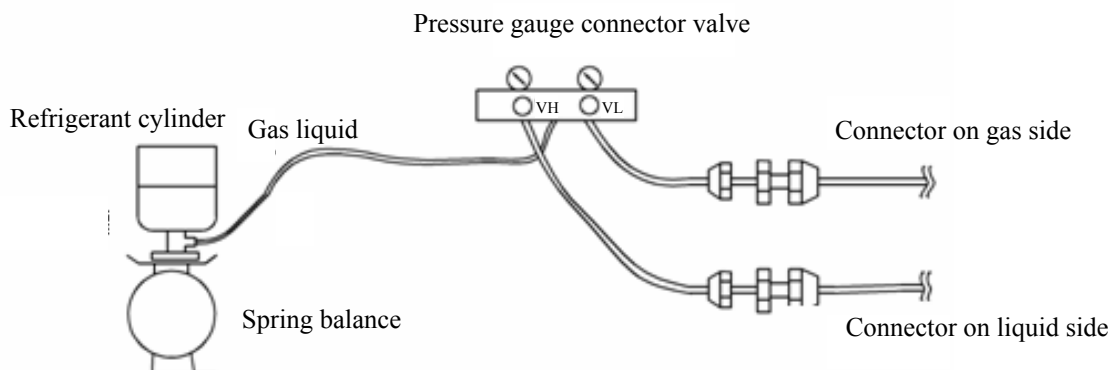

b. Open pressure gauge valve VH, then fill liquid state refrigerant into the liquid pipe side until required amount is reached.

If refrigerant can not be charged in system unless the unit is turned on, let the system run at full-load cooling mode. Open VH and discharge air in the hose. The high pressure end of pressure gauge is connected to the refrigerant filling nozzle on the small valve of outdoor unit. Open VL and charge gas state refrigerant into the gas pipe until required charging amount is reached.

c. Observe electronic balance or spring balance. When required amount is reached, the valve shall be closed very quickly and then source valve on the refrigerant valve shall be shut off

d. The amount of charging refrigerant shall be recorded.

Refrigerant charge shall be recorded as per the following table.

Unit Mark	Amount of charging refrigerant(kg)
Unit 1	
Unit2	
.....	
Unitn	

## 6 INSTALLATION OF CONDENSATE PIPE

### 6.1 Material Quality Requirements for Condensate Pipe

Generally, the condensate pipe shall be water supply U-PVC pipe, adhered by using special glue. The other materials available include: PP-R pipe, PP-C pipe and hot-dipped galvanized steel pipe. It is not allowed to use aluminum plastic composite pipe.

### 6.2 Key Points for Condensate Pipe Installation

#### 6.2.1 Work Order

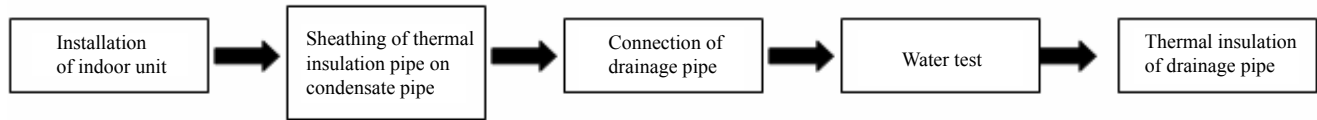

6.2.2 Determine the direction and elevation of condensate pipe before installation. To ensure the gradient smooth and straight, avoid intersecting with other pipelines. The height of the clamp fixing the pipe hanger frame shall be adjustable and fixed from the outer of thermal insulation.

#### 6.2.3 Distance between hanger frames:

Outer diameter of water pipe (mm)	$\phi \leq 25$	$32 > \phi \geq 25$	$\phi \geq 32$
Spacing between horizontal pipes (mm)	800	1000	1500
Spacing between standpipes (mm)	1500		2000

Each standpipe shall have two hanger frames at least.

6.2.4 The gradient of condensate pipe shall be over 1% and the gradient of main pipe shall not be less than 0.3%, while there shall be no overhanging slope.

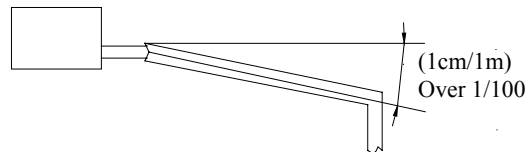

6.2.5 When connecting the 3-way section of condensate pipe, the 2-way straight section on 3-way pipe shall be on the same gradient. The two ends of 2-way section shall not have different gradient. See the schematics below:

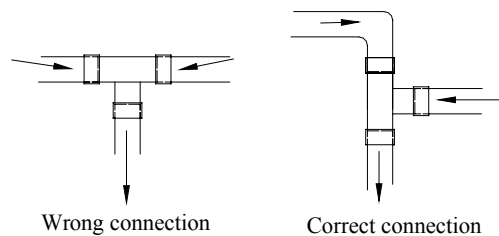

6.2.6 Confluence toward the horizontal pipe shall be best from the upper. Back flow is easy to occur if from the lengthwise direction.

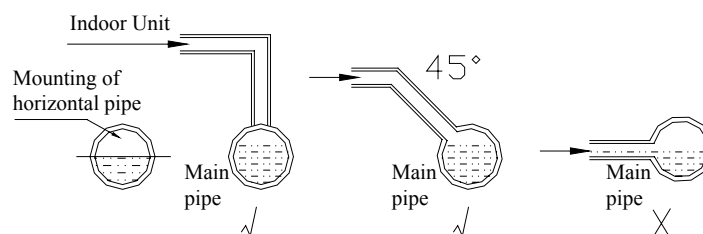



6.2.7 Do not tie the condensate pipe and refrigerant pipe together.

6.2.8 To ensure smooth drainage of condensate, a vent hole shall be set at the highest point of drainage pipe.

6.2.9 Carry out water flow test and full water test after the pipe connection is completed. On one hand, check if the drainage is smooth; on another hand, check the piping system for any leakage.

6.2.10 Steel sheath shall be provided to the pipe crossing the wall or slab. The pipe joint shall not be positioned within the sheath. The steel sheath shall be flush with the wall surface or slab base, but 20mm higher than the slab base. The sheath shall not affect the pipe gradient. The clearance between pipe and sheath shall be blocked by using flexible inflammable materials. The sheath shall not be used as the supporting point of the pipe.

6.2.11 The joint of thermal insulation materials must be adhered by using special glue and then wrapped with plastic tape having a width not less than 5cm to avoid condensing.

6.2.12 Ensure a gradient over 1% when connecting the drainage pipe to the indoor unit.

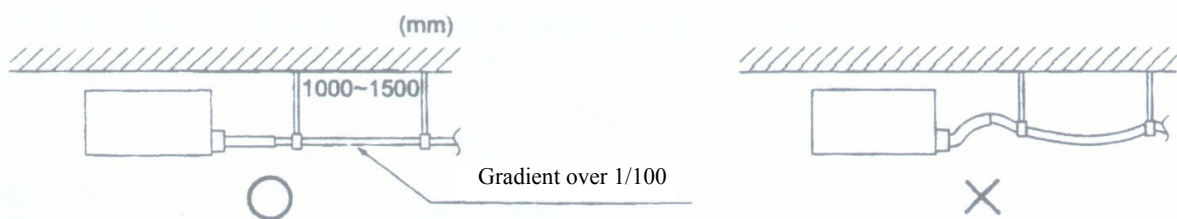

6.2.13 When connecting the drainage pipe to the indoor unit, please fix with the included pipe clamp and do not use glue water, thus to ensure easy repair.

6.2.14 Installation requirements for auxiliary drainage pipe

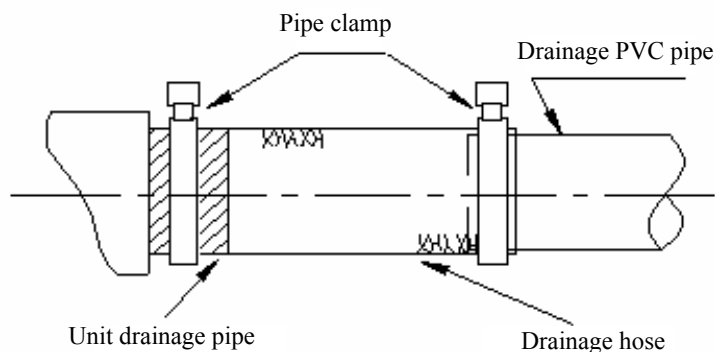

The auxiliary drainage pipe must be thermally insulated:

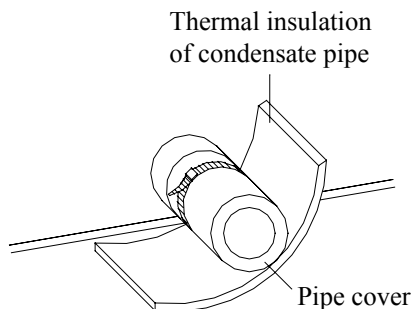

6.2.15 The long drainage pipe may be fixed by using hanger bolts, thus to ensure a gradient of 1/100 (PVC cannot be bent).

The spacing between the supports of horizontal pipe is 0.8-1.0m. Twisting will be caused and thus air bag will be formed if the spacing is too high. Once the air bag is formed, the pump can only compress the air bag no matter how forcible it pushes, but there is no flowing water, thus resulting in abnormal water level. This will cause flooding of the ceiling.

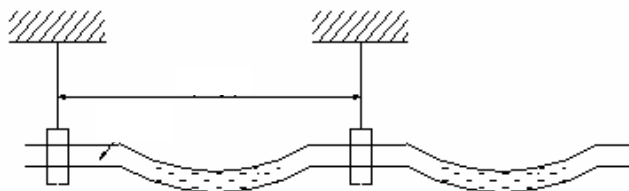

6.2.16 If the air flow of indoor unit is high, this might cause negative pressure and result in return suction of outdoor air. Therefore, U-type water trap shall be designed on the drainage side of each indoor unit.

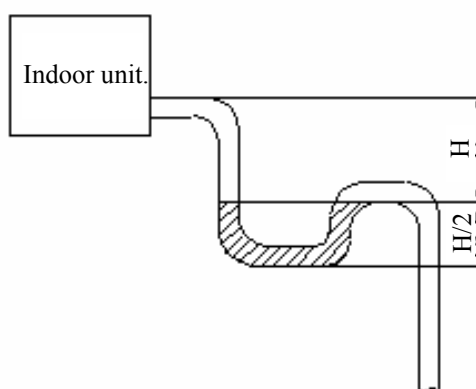

- ◆ Install water trap as shown below;
- ◆ Install one water trap for each unit.
- ◆ Installation of water trap shall consider easy cleaning in the future.

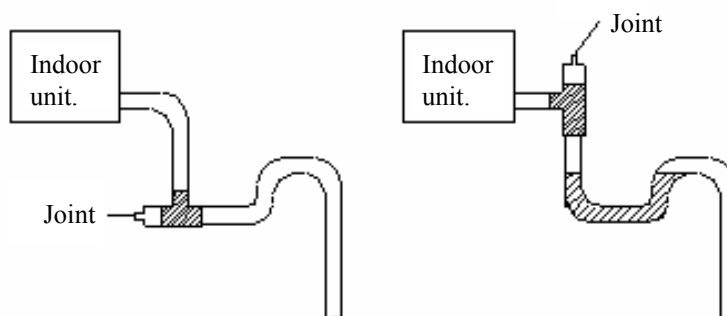

### 6.2.17 Connection of drainage branch pipe to the standpipe or horizontal pipe of drainage main pipe.

The horizontal pipe cannot be connected to the vertical pipe at a same height. It can be connected in a manner as shown below:

NO1: 3-way connection of drainage pipe joint

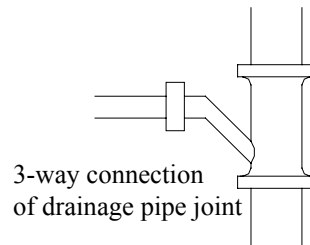

NO2: Connection of drain elbow

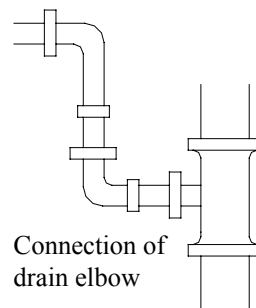

NO3: Connection of horizontal pipe

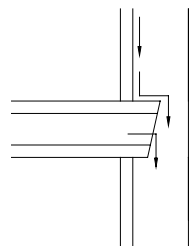

Drainage pipe is requisite for air conditioner unit. During cooling, the moisture in the air will condense on the surface of evaporator. Such condensing water must be drained out of the unit. Meanwhile, the drainage pipe has an important role to determine if the air conditioner can plays its full functions.

6.2.18 All the condensate pipes must be installed at a distance over 500mm from the electric box of the unit.

### 6.3 Test for Condensate Pipe

The water test for condensate pipe includes closed water test and drainage test. The closed water test is focused on checking if the drainage pipe system is well sealed and if there is any leakage. The drainage test is focused on checking if the drainage pipe system can drain water smoothly and thoroughly and ensuring that there is no water deposit (except the specially designed water trap).

After connection of the drainage pipe is completed, firstly carry out closed water test. Seal the outlet of drainage pipe with adhesive tape or plug. Then, fill water into the drainage pipe system form indoor unit side. Stop filling after ensuring that all the drainage pipes are filled with water. After 24 hours, check all the joints of water pipe for any leakage. If any, repair and reinstall. If no leakage, proceed to drainage test.

Remove the adhesive tape or plug from the drainage pipe. Check the water tray and drainage pipe of indoor unit if the drainage is thorough and if there is any water deposit. If any, readjust it. If not, complete the water test and proceed to the thermal insulation on all pipe joints.

### 6.4 Requirements of Heat preservation

#### ◆ Heat Insulation Materials

The thermal insulation material of obturator foam shall be used. Fireproof level: B1.

The thermal conductivity shall not be higher than 0.035w/ (m·k) when the average temperature is 0 °C.

◆ Thickness of thermal insulation layer

The thickness of thermal insulation layer on condensate pipe shall be over 10mm.

◆ The joint of thermal insulation materials must be adhered by using special glue and then wrapped with plastic tape having a width not less than 5cm to avoid condensing.

◆ Thermal insulation is not required for the outdoor section of condensate pipe.

## 7 ELECTRICAL INSTALLATION

### 7.1 Precautions for Electrical Installation

◆ The wiring must be in accordance with the local rules.

◆ Rated supply voltage and special circuit for air conditioner must be used.

◆ Do not pull the power cord.

◆ All the electric installations must be carried out by specialist technicians in accordance with the local laws, rules and these instructions.

◆ The diameter of flexible wire should be wide enough. Replace the damaged power cord and connecting wire with special flexible wire.

◆ The earthing shall be reliable and connected to the special earthing device on the construction. The installation must be done by specialist technicians. The leak protection switch and air switch with enough capacity must be installed. The air switch shall have both the magnetic tripping and thermal tripping functions to ensure protection against the short circuit and overload.

● **Earthed Requirements**

◆ The air conditioner belongs to I type electric appliances. The reliable earthed action is a must.

◆ The yellow and green wire inside the air conditioner is the earthed wire. Do not use it for other purpose or even cut off it. Do not fix it with tapping screw,. Otherwise, it may cause electric shock.

◆ The earthed resistance must meet the requirements of national standard GB17790.

◆ There should be reliable earthed terminal for the power supply. Never connect the earth lead to the following articles:

- ① water pipe; ② gas pipe; ③ drain pipe; ④ unreliable place considered by professionals.

### 7.2 Specifications Of Power Cord & Circuit Breaker

Type HP Number	Model	Power	Total vacuum switch capacity	Vacuum switch for each combination unit	Total power wire diameter	Wire diameter for each combination unit
8	GMV-Pdm224W/NaB-M	380-415V-3Ph-50Hz	32	32	6.0	6.0
10	GMV-Pdm280W/NaB-M	380-415V-3Ph-50Hz	32	32	6.0	6.0
12	GMV-Pdm335W/NaB-M	380-415V-3Ph-50Hz	40	40	10.0	10.0
14	GMV-Pdm400W/NaB-M	380-415V-3Ph-50Hz	40	40	10.0	10.0
16	GMV-Pdm450W/NaB-M	380-415V-3Ph-50Hz	40	40	10.0	10.0
18	GMV-Pdm504W/NaB-M	380-415V-3Ph-50Hz	63	32+32	16.0	6.0+6.0
20	GMV-Pdm560W/NaB-M	380-415V-3Ph-50Hz	63	32+32	16.0	6.0+6.0
22	GMV-Pdm615W/NaB-M	380-415V-3Ph-50Hz	63	32+40	25.0	6.0+10.0
24	GMV-Pdm670W/NaB-M	380-415V-3Ph-50Hz	80	32+40	25.0	6.0+10.0
26	GMV-Pdm730W/NaB-M	380-415V-3Ph-50Hz	80	32+40	25.0	6.0+10.0
28	GMV-Pdm785W2/NaB-M	380-415V-3Ph-50Hz	80	40+40	25.0	10.0+10.0
30	GMV-Pdm850W2/NaB-M	380-415V-3Ph-50Hz	80	40+40	25.0	10.0+10.0
32	GMV-Pdm900W2/NaB-M	380-415V-3Ph-50Hz	80	40+40	25.0	10.0+10.0

34	GMV-Pdm950W3/NaB-M	380-415V-3Ph-50Hz	125	32+32+40	35.0	6.0+6.0+10.0
36	GMV-Pdm1008W3/NaB-M	380-415V-3Ph-50Hz	125	32+32+40	35.0	6.0+6.0+10.0
38	GMV-Pdm1065W3/NaB-M	380-415V-3Ph-50Hz	125	32+40+40	35.0	6.0+10.0+10.0
40	GMV-Pdm1130W3/NaB-M	380-415V-3Ph-50Hz	125	32+40+40	35.0	6.0+10.0+10.0
42	GMV-Pdm1180W3/NaB-M	380-415V-3Ph-50Hz	125	32+40+40	35.0	6.0+10.0+10.0
44	GMV-Pdm1235W3/NaB-M	380-415V-3Ph-50Hz	125	40+40+40	35.0	10.0+10.0+10.0
46	GMV-Pdm1300W3/NaB-M	380-415V-3Ph-50Hz	125	40+40+40	35.0	10.0+10.0+10.0
48	GMV-Pdm1350W3/NaB-M	380-415V-3Ph-50Hz	125	40+40+40	35.0	10.0+10.0+10.0
50	GMV-Pdm1405W4/NaB-M	380-415V-3Ph-50Hz	160	32+32+40+40	35.0	6.0+6.0+10.0+10.0
52	GMV-Pdm1456W4/NaB-M	380-415V-3Ph-50Hz	160	32+32+40+40	50.0	6.0+6.0+10.0+10.0
54	GMV-Pdm1512W4/NaB-M	380-415V-3Ph-50Hz	160	32+40+40+40	50.0	6.0+10.0+10.0+10.0
56	GMV-Pdm1570W4/NaB-M	380-415V-3Ph-50Hz	160	32+40+40+40	50.0	6.0+10.0+10.0+10.0
58	GMV-Pdm1650W4/NaB-M	380-415V-3Ph-50Hz	160	32+40+40+40	50.0	6.0+10.0+10.0+10.0
60	GMV-Pdm1700W4/NaB-M	380-415V-3Ph-50Hz	160	40+40+40+40	50.0	10.0+10.0+10.0+10.0
62	GMV-Pdm1750W4/NaB-M	380-415V-3Ph-50Hz	160	40+40+40+40	50.0	10.0+10.0+10.0+10.0
64	GMV-Pdm1800W4/NaB-M	380-415V-3Ph-50Hz	160	40+40+40+40	50.0	10.0+10.0+10.0+10.0

### 7.3 Wiring Sketch Map

#### 7.3.1 Wiring Sketch Map between Outdoor Unit

The indoor and outdoor unit is energized separately.

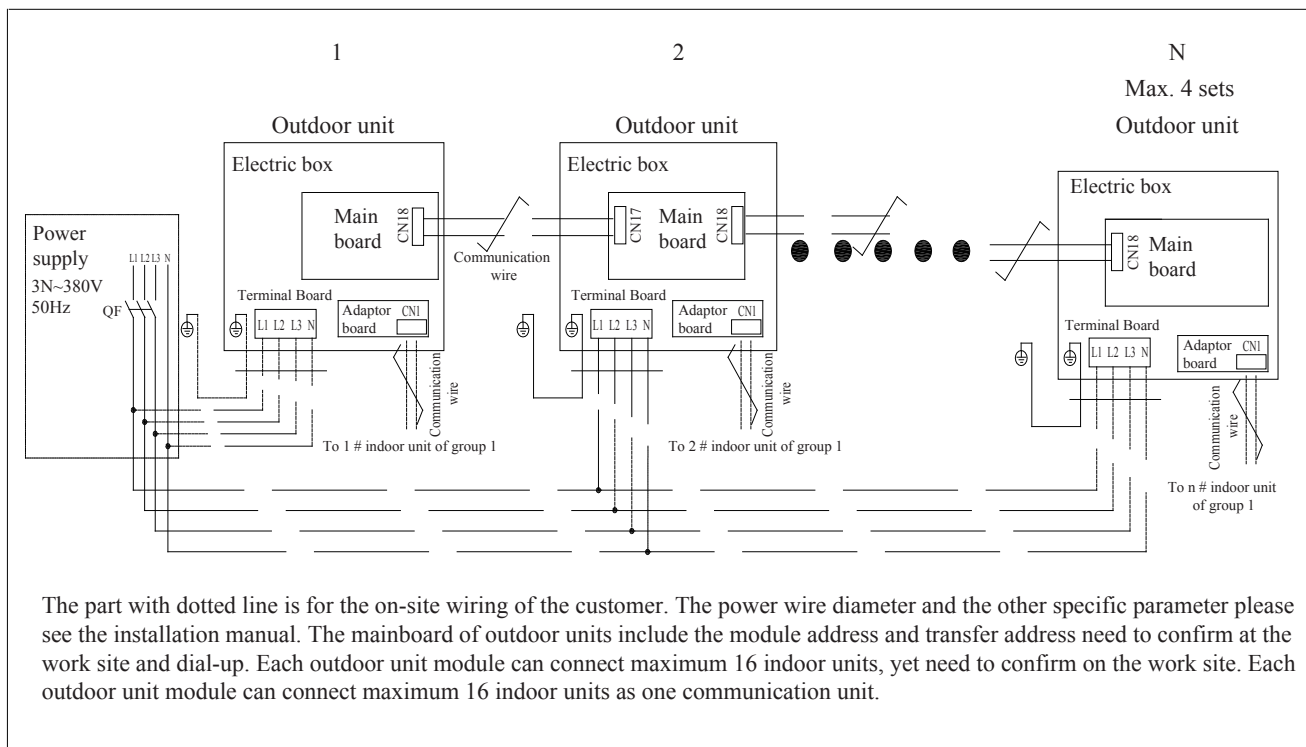

### 7.3.2 Wiring Sketch Map between Indoor Unit

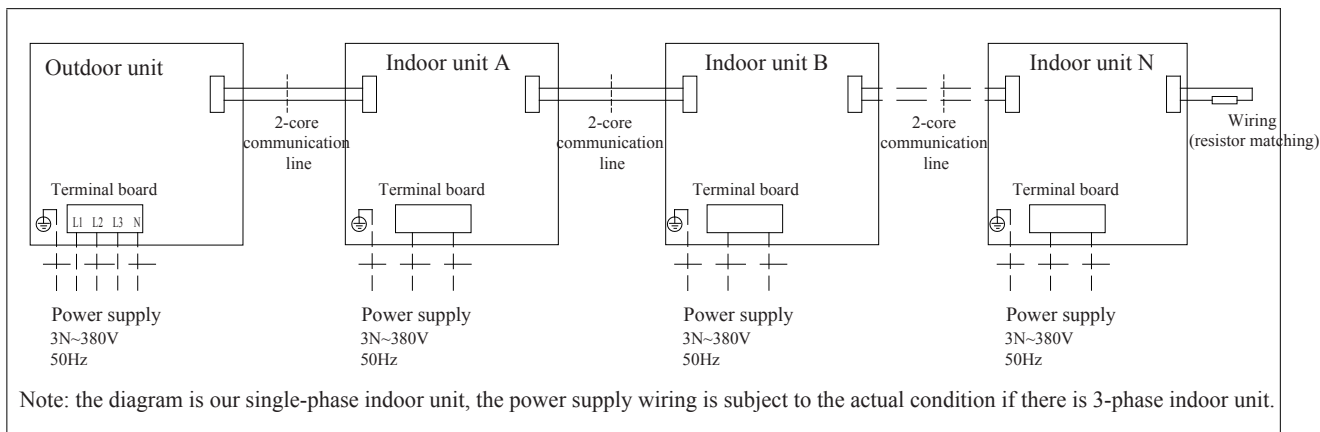

**Notes:**

- a. The last indoor unit requires to install another communication line as wiring (resistor matching);
- b. Both the communication lines of outdoor units and indoor units are cascade connection.
- c. Connect the communication lines of indoor units and out units according to the above diagram.

### 7.3.3 Connection of communication line

#### 7.3.3.1 Communication of GREE D.C. inverter units includes:

- 1).Communication between outdoor unit and indoor unit;
- 2).Communication among indoor units;
- 3).Communication among outdoor units (modules combination);
- 4).Communication among patch boards of outdoor units (when the patch boards need to be added.).
- 5).Communication Connection Diagram

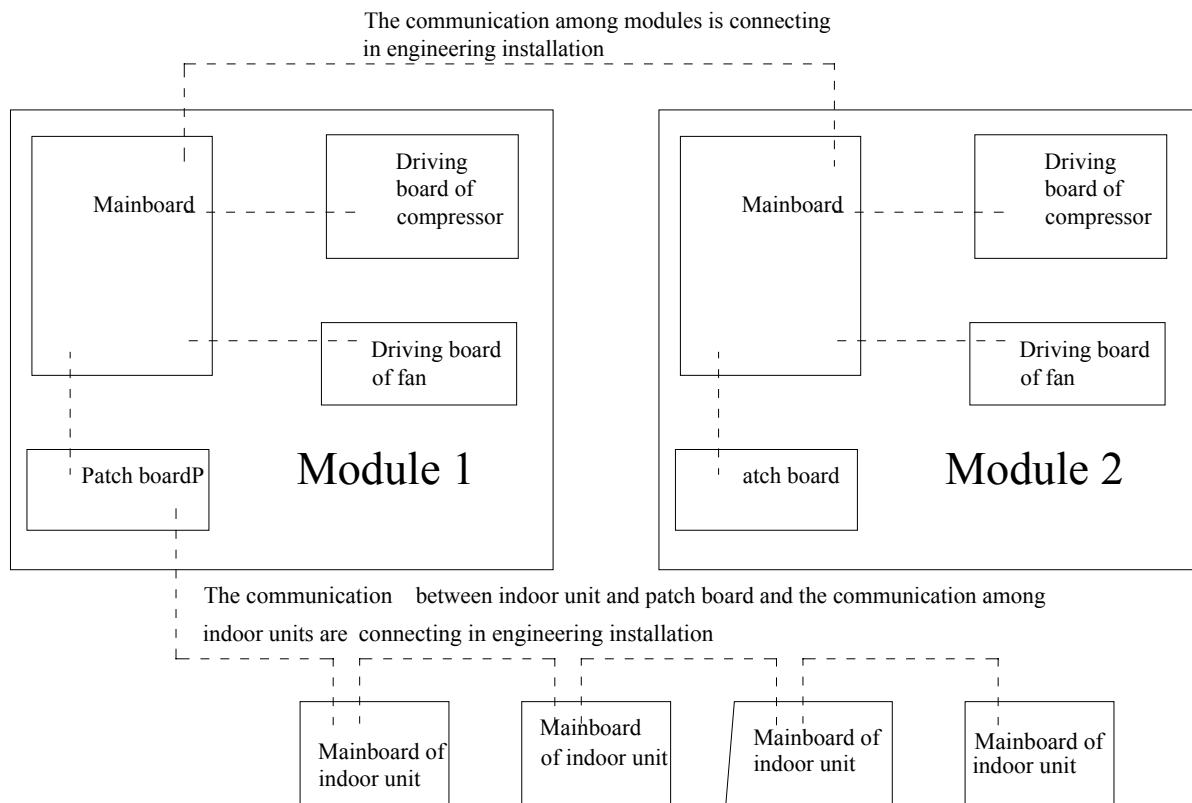

### 7.3.3.2 Communication Mode of GREE D.C. Inverter Units

- 1). All communication modes are 485 communications.
- 2). Network of indoor units: outdoor unit  $\longleftrightarrow$  indoor unit to indoor unit  $\longleftrightarrow$  2-pin twisted wire is applied for communication among indoor units and its both ends are 3-pin XH plugs.(2<sup>nd</sup> and 3<sup>rd</sup> positions are applied and shall be corresponding).
- 3). Network of outdoor units: module  $\longleftrightarrow$  2-pin twisted wire is applied for communication among indoor units and its both ends are 4-pin XH plugs(2nd and 3rd positions are applied and shall be corresponding).

### 7.3.3.3 Communication Address Setting

Communication address setting includes: address setting of indoor units, address setting of wired controller, address setting of communication of outdoor units, qty setting of outdoor modules and address setting of communication of patch boards.

### 7.3.4 Connection of Communication System.

#### 7.3.4.1 Communication among modules is realized by communication wire on mainboard of each module.

Directly connect mainboard by 2-pin and 4-port communication wire to realize communication among outdoor modules. The communication interface ports on mainboard are CN16, CN17 and CN18, each of which are available.

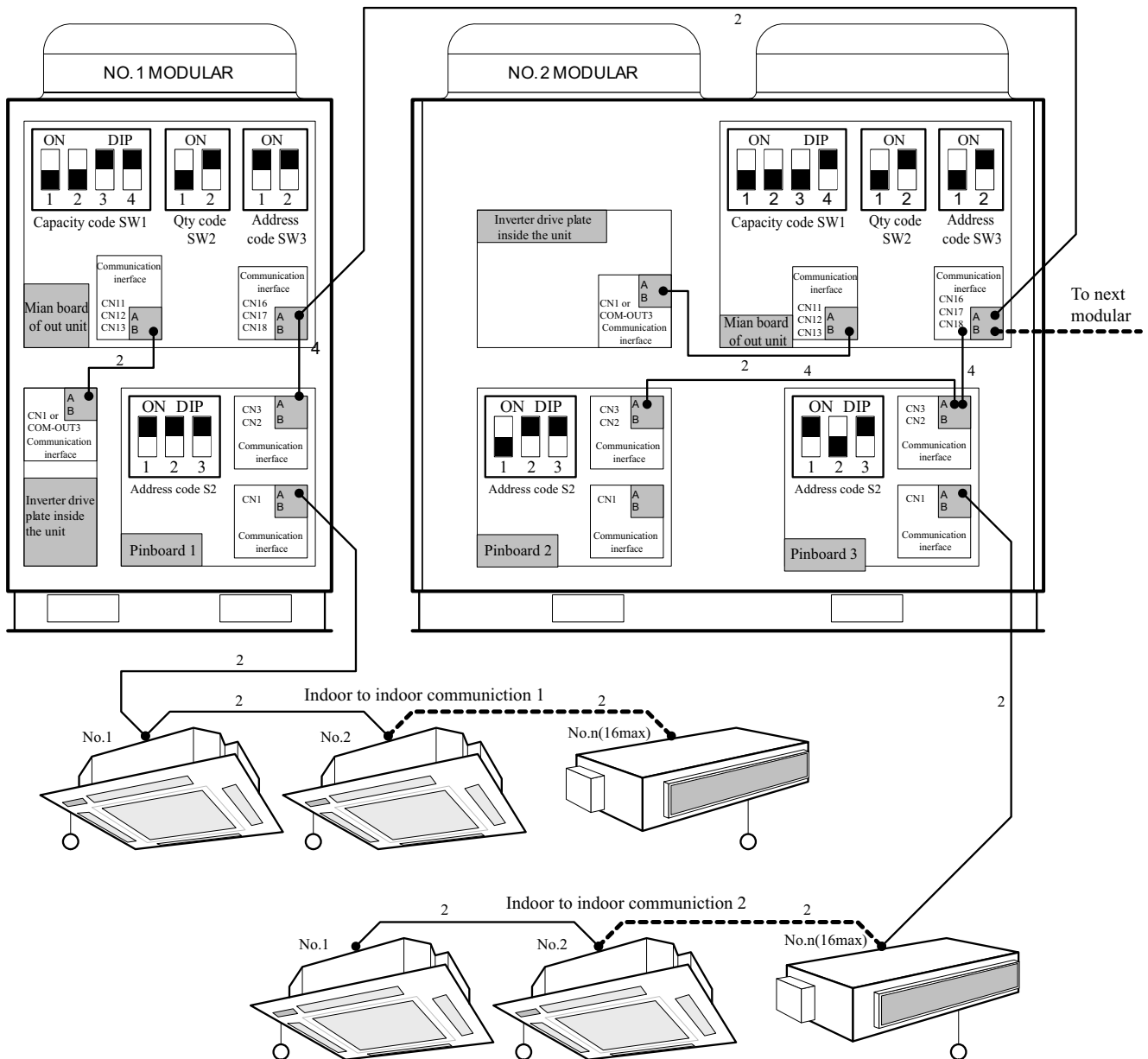

7.3.4.2 Communication between indoor unit and outdoor unit is realized by connecting mainboard of indoor unit and patch board of outdoor unit.

1) When there is only one outdoor module, and also, the qty of indoor units is less than 16, the outdoor unit connect with indoor unit by communication wire which directly connect patchboard of outdoor unit to mainboard of indoor unit. Communication wire is 2-pin twisted wire and its both ends are 3-pin XH plugs (2nd and 3rd positions are applied and shall be corresponding)

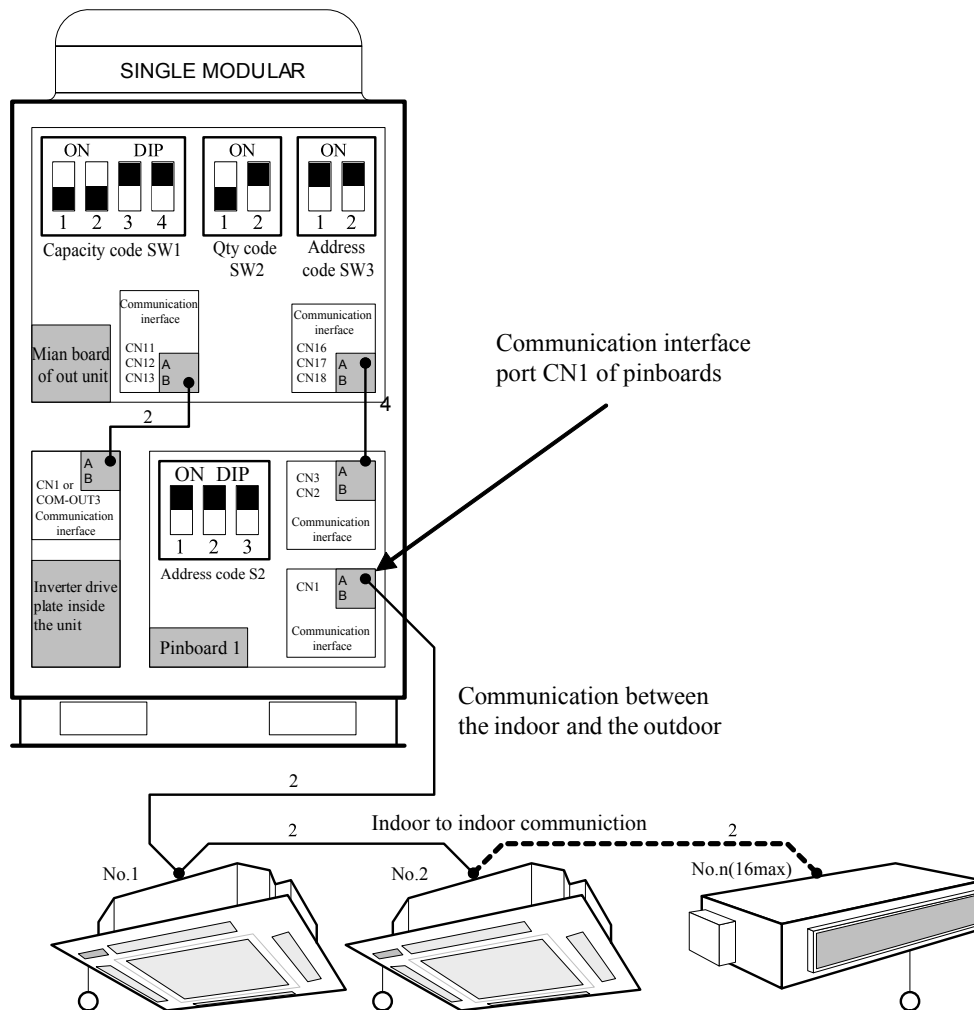



2) When there is only one outdoor module and also, the qty of indoor units is more than 16 but less than 32, one patch board shall be added to outdoor unit, which can connect up to 16 sets of indoor units. The corresponding port of patch board is CN1.

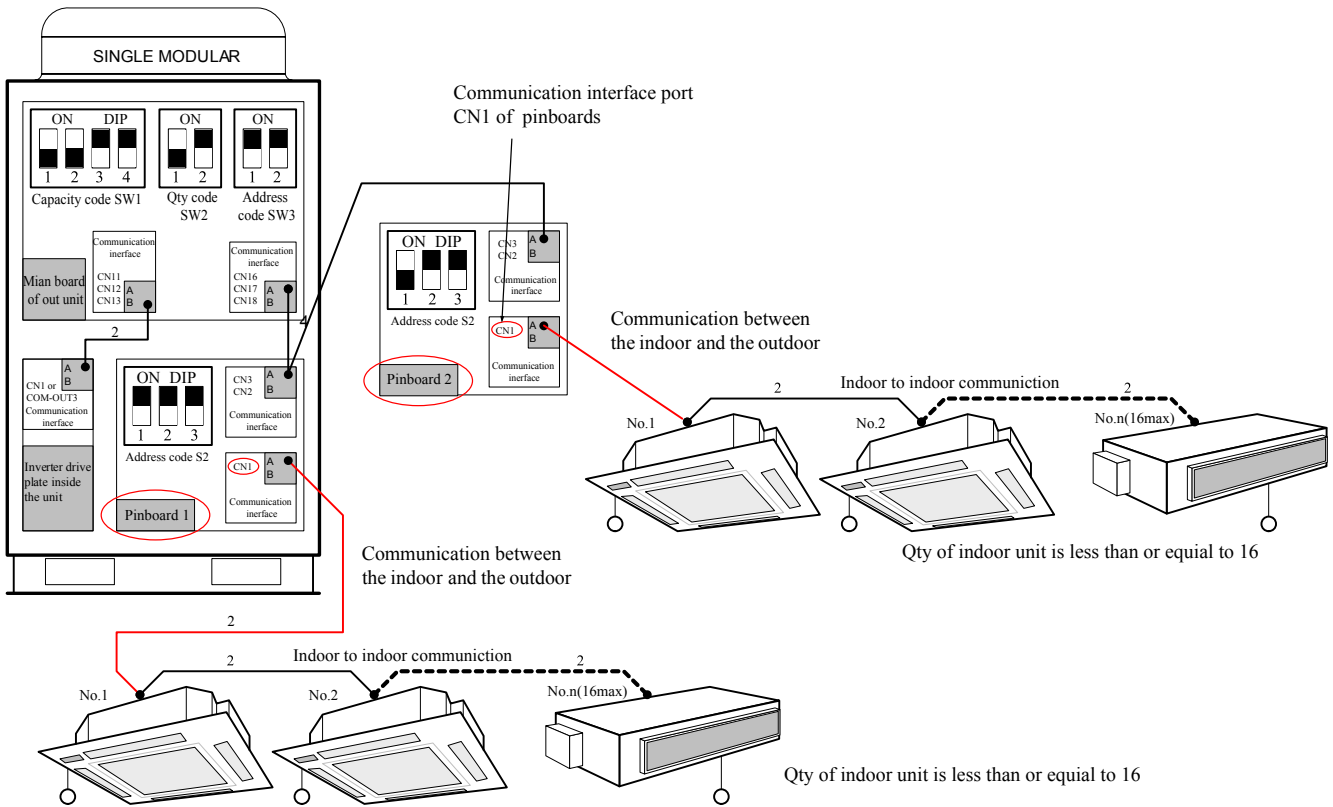

3) When the qty of outdoor units is more than 2 and the the qty of indoor units is not more than 16 sets, the indoor to outdoor communication is realized by connecting one indoor unit to a patch board of one outdoor module.

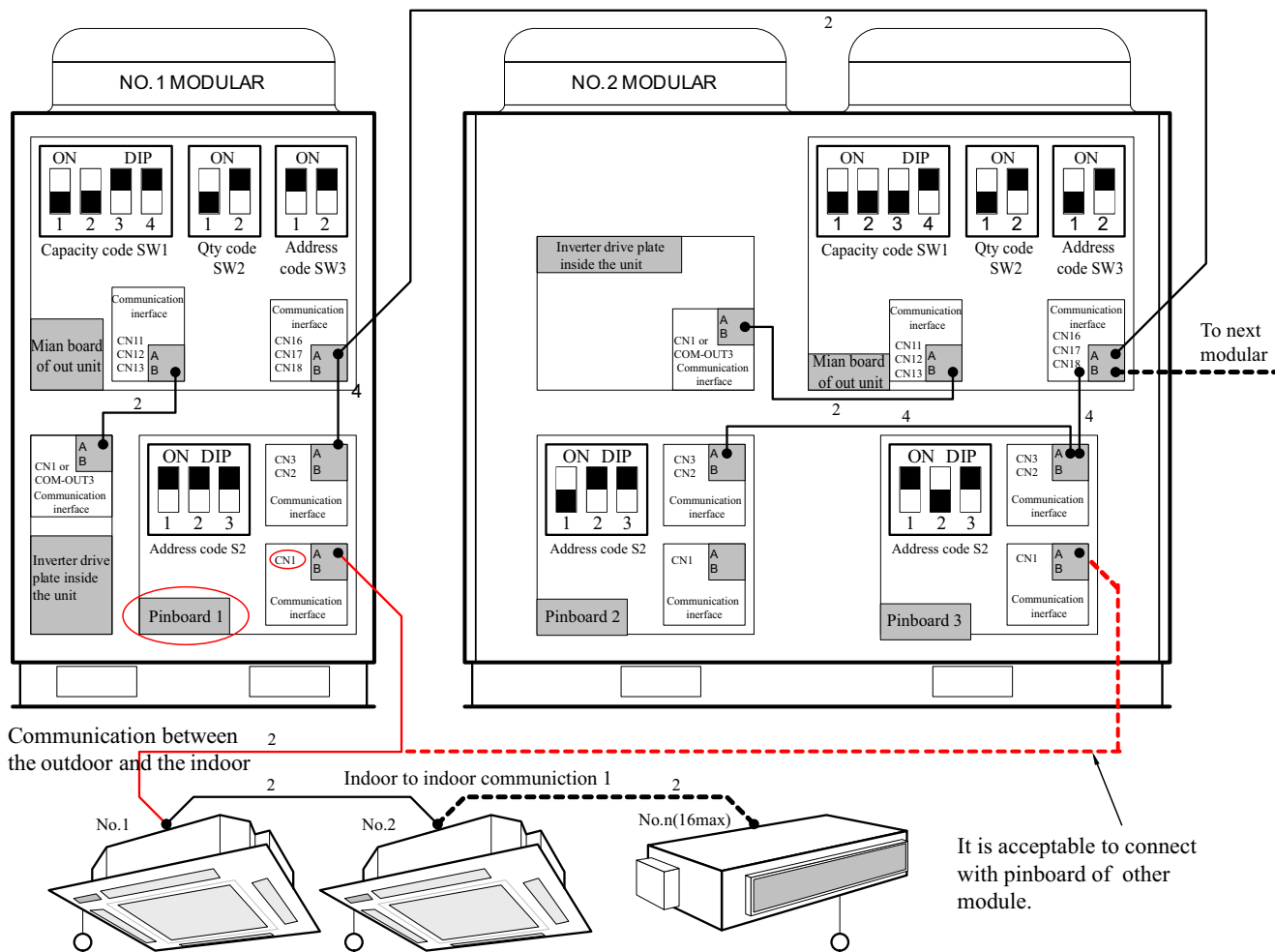

Qty of indoor unit is less than or equal to 16

4) When the qty of outdoor units is more than 2 and the the qty of indoor units is not more than (N×16) sets, there is no need for adding patch board. The qty if indoor units connected by each patch board shall be not more than 16 sets. The corresponding interface port of patch board is CN1.

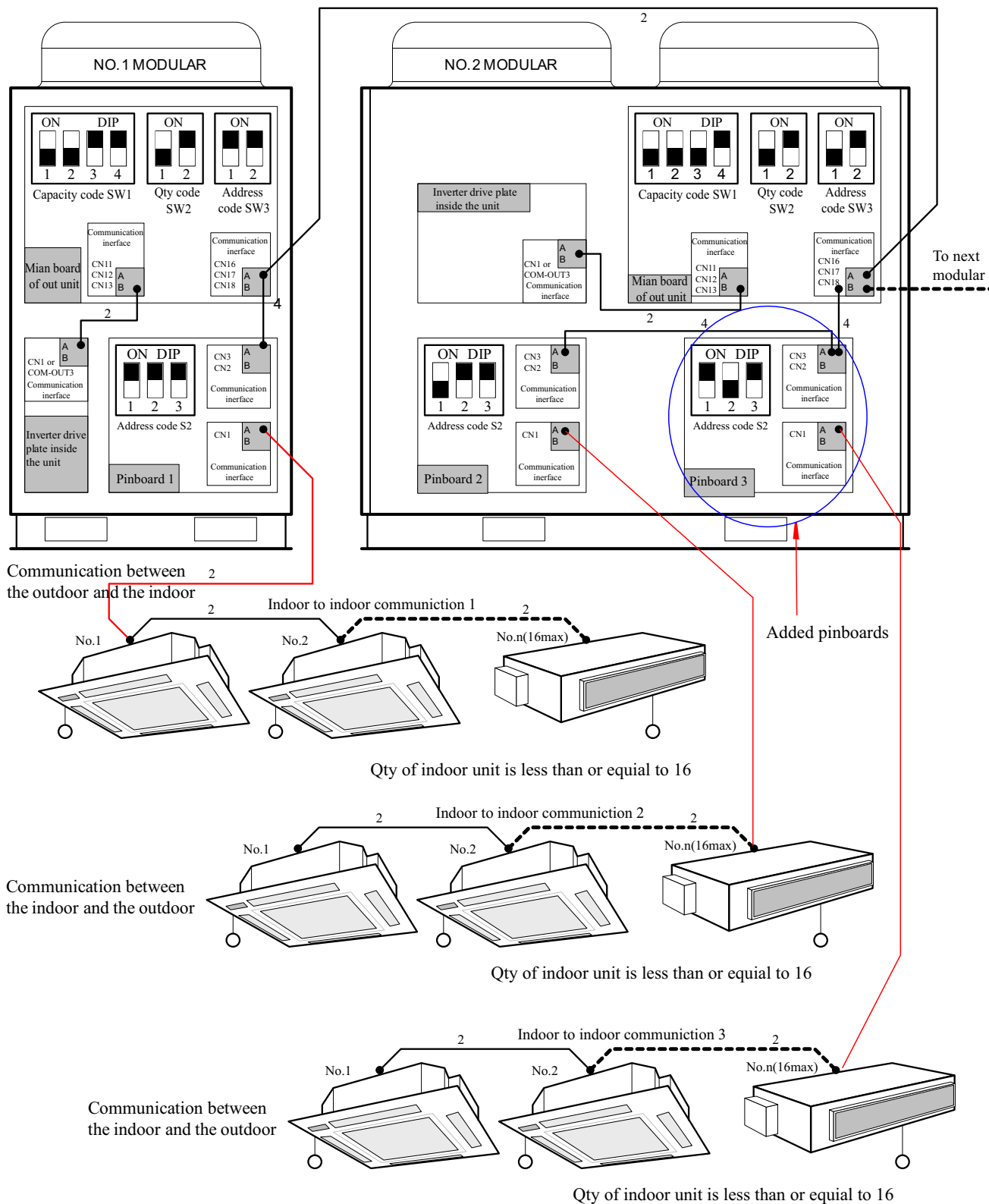

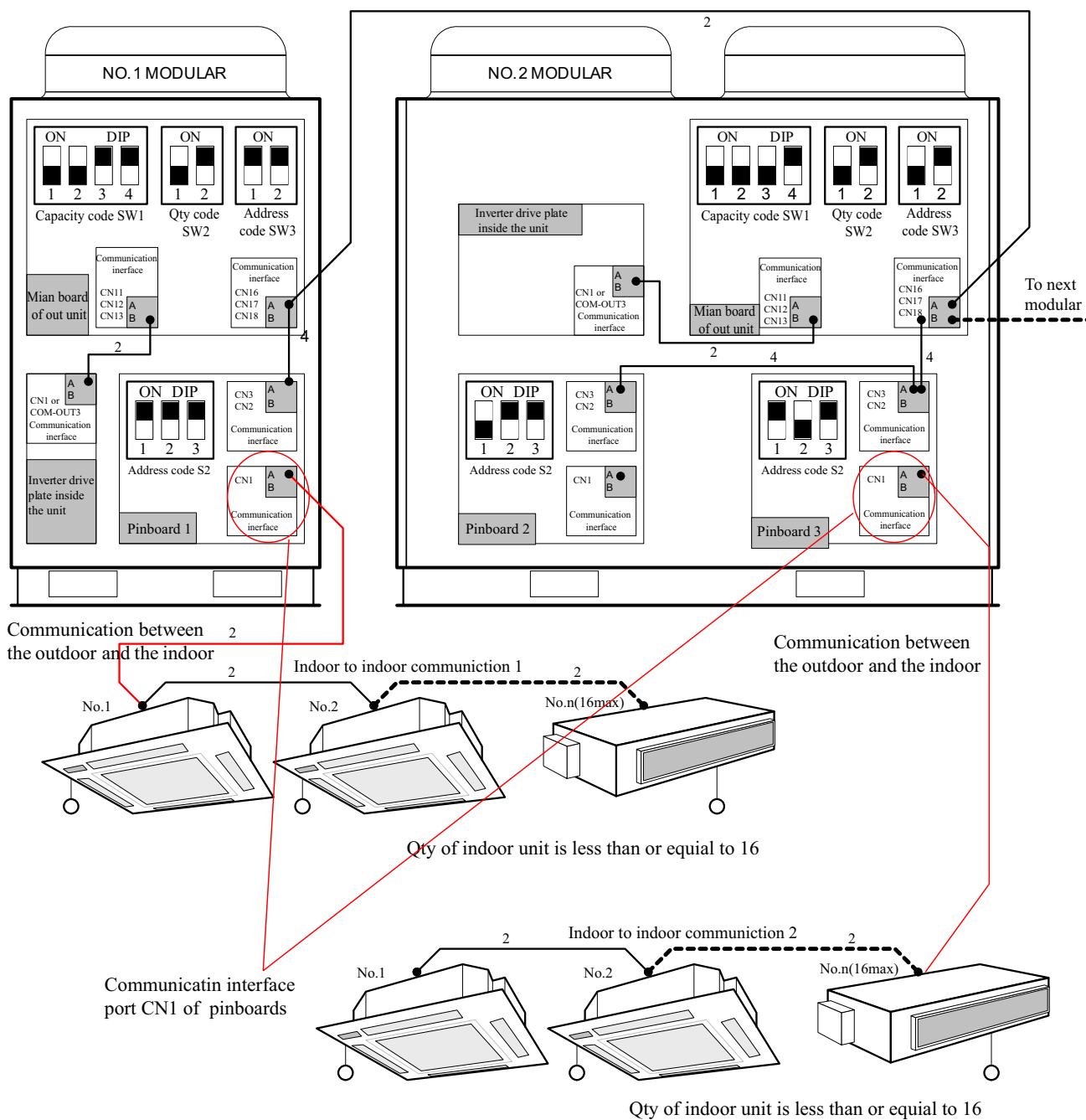

Communication between the outdoor and the indoor

Indoor to indoor communication 1

Communication between the outdoor and the indoor

Qty of indoor unit is less than or equal to 16

Communication interface port CN1 of pinboards

Indoor to indoor communication 2

Qty of indoor unit is less than or equal to 16

5) When the qty of outdoor units is more than 2 and the the qty of indoor units is more than  $(N \times 16)$  sets, X sets of the patch board shall be added for outdoor untis,  $X = \lceil \frac{\text{total indoor units qty} - (N \times 16)}{16} \rceil$ .

The qty if indoor units connected by each patch board shall be not more than 16 sets. The corresponding interface port of patch board is CN1.

7.3.4.3 Each module is equipped with one patch board to connect maximum 16 sets of indoor units. The calculation of qty of patch boards:  $\text{Qty} = \frac{\text{the total amount of indoor units in a same refrigerating system}}{16}$ ; When the one patch board equipped is not enough, patch boards shall be added and maximum 8 patch boards can be connected in a system.

Eg: There are 2 outdoor modules and each one equips with a patch board which can maximum connect 16 sets of indoor units. So there are 32 sets of inddor units can be connected. There are 45 indoor units actually so the following qty of patch boards shall be added :  $(45 - 32) / 16 = 0.81$ . That means one patch board shall be added.

7.3.4.4 When extra patch board shall be added, the added patch board can directly connect with the original patch board.

### 7.3.4.5 Connection of Indoor to Indoor Communication

The connection of communication among indoor units is limited in the network of the same patch board which can connect maximum 16 sets of indoor units.

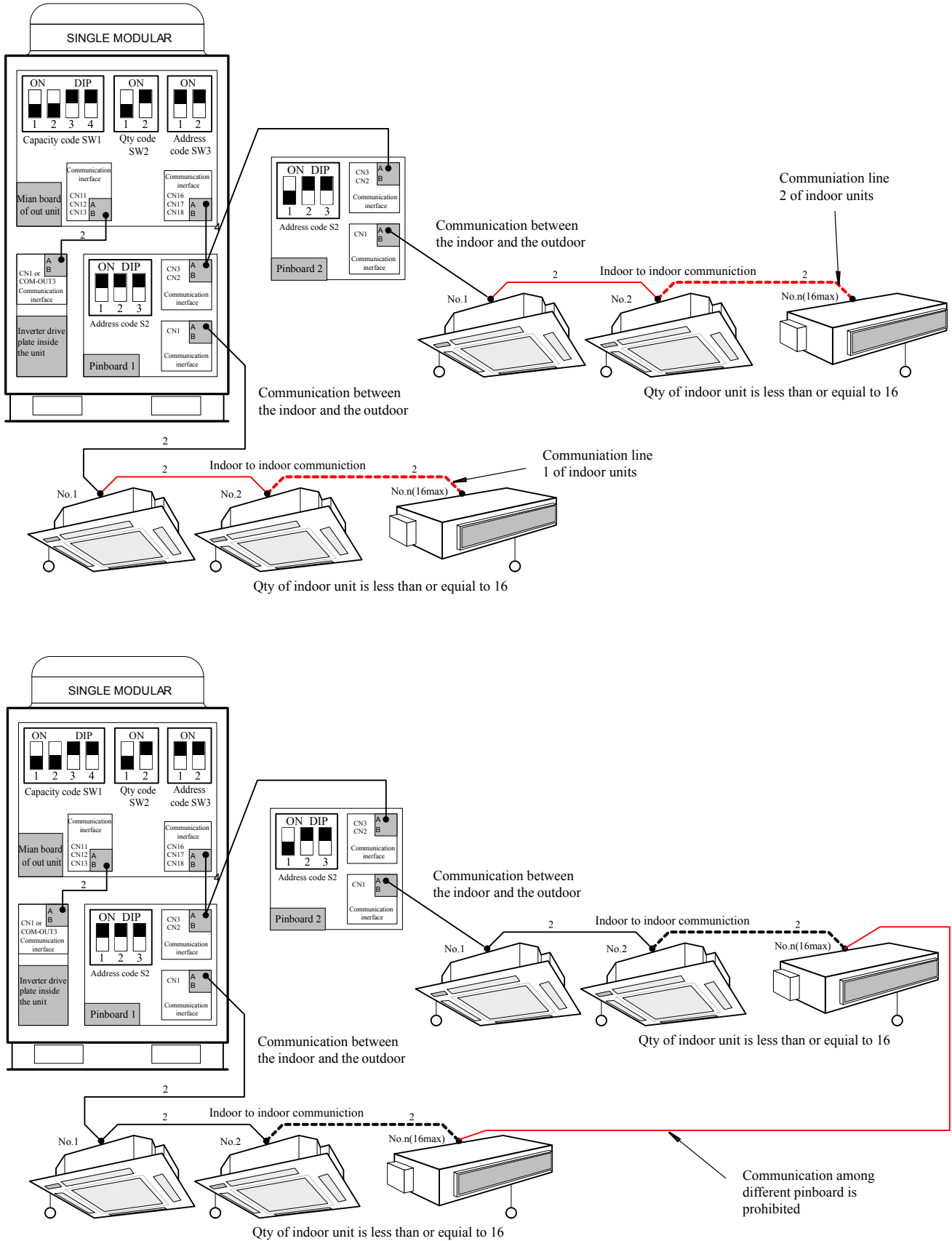

## 7.4 Dial-up of Unit

The DC inverter GMV unit of Gree is provided with three dial-ups, i.e. address dial-up, capacity dial-up and function dial-up. Adjust the function dial-up to set control, mode and function; Adjust the address dial-up to set the corresponding relationship of indoor unit and wired controller; Adjust the capacity dial-up to set capacity demand of indoor unit.

### 7.4.1 Function Dial-up

**Caution!**

Functional dial switch S7 is located on the mainboard of the indoor unit. It is operated when the user need to change the default setting.

Functional dial switch S7			
Dial-up Switch	Functional Description:	Dial-up Setting	
		0 (ON Position)	1
1(S / R)	Setting of memory mode	Standby (S)	Restore (R)
2(L / I)	Setting of control mode	Wired control (L)	Remote control (I)
3(M / S)	Setting of master / slave indoor unit	Master indoor unit (M)	Slave indoor unit (S)
4(I / O)	Setting of ambient temperature acquisition point	Air inlet (I)	Receiver (O)
5(L / H)	Setting of high / low static pressure fan	Low static pressure (L)	High static(H)

Functional description of function dial-up:

#### Dial-up switch 1 (S/R):

Setting of memory mode, including the standby mode and restoration mode. The standby mode refers to that the previous parameters will be kept but the unit will not run automatically after the power supply is resumed. This setting is factory defaulted (dial-up switch pulled to “ON” position). For example, if the parameters of an indoor unit set before power shutdown are High Fan and 24°C, the unit will be under standby state after the power supply is resumed and after the unit is manually started, the parameters will remain as High Fan and 24°C. The restoration mode refers to that not only the previous parameters will be kept, but also that the unit can start automatically after the power supply is resumed. But if the unit is under STOP state before power shutdown, it will be also under STOP state after the power supply is resumed.

#### Dial-up switch 2 (L/I):

Setting of control mode, including wired control and remote control. The wired control mode refers to that the indoor unit is controlled from wired controller (hand controller). This setting is factory defaulted (dial-up switch pulled to “ON” position). When the setting is wired control mode, the function dial-up on S7 for “setting of memory mode” and “setting of master / slave indoor unit” will be disabled. These two settings can be done from the wired controller directly. The remote control mode refers to that the indoor unit is controlled from remote controller. When the setting is remote control mode, its function dial-up must be set on S7.

#### Dial-up switch 3 (M/S):

The setting of master / slave indoor unit refers to the master / slave setting of indoor run mode, mainly used to meet the needs of special people on priority (e.g. leader, patients, etc). The factory default setting is that all indoor units are master (dial-up switch pulled to “ON” position).

When all the indoor units are set as slave, the outdoor unit will run according to the mode of slave indoor unit that is firstly started. If the mode of slave indoor unit started later has in conflict against the mode started earlier, the system will display mode conflict error, so that the indoor unit started later cannot work. In this case, the run mode of the unit is decided by the slave indoor unit that is firstly started.

When only one indoor unit is set as master, no matter if the master indoor unit is firstly started or not, the slave indoor unit will give out mode conflict error as long as its mode is in conflict against the mode of master indoor unit (except that the master indoor unit is stopped). In this case, the unit run according to the mode of master indoor unit on priority.

When several indoor units are set as master, the mode of master indoor unit with a lower address code will be taken as the master run mode of the unit. when the master indoor unit with the lowest address code is

changed from STOP state to RUN state, the mode of other master indoor units or slave indoor units shall be kept identical to its mode; otherwise the system will give out mode conflict error. Therefore, when there are several master indoor units, the address code of the unit shall be set from lower to higher according to priority level.

#### Dial-up switch 4 (I/O):

Setting of ambient temperature acquisition point. This setting is mainly used when the temperature of air conditioner area differs largely from the air inlet temperature of the unit. Meanwhile, this setting is only valid when the receiver is connected, including the setting of temperature acquisition point at air inlet and setting of the temperature acquisition point at receiver head. The factory default setting is acquisition of air inlet temperature (dial-up switch pulled to “ON” position).

Dial-up switch 5 (L/H): Setting of high / low static pressure fan. This setting includes the setting of high static pressure fan and low static pressure fan, adjusted as needed for the project. The factory default setting is low static pressure fan (dial-up switch pulled to “ON” position).

#### Cautions:

- 1) The above settings must be done under power shutdown state.
- 2) The dial-up switch of function code is classified into 3-bit code, 4-bit code and 5-bit code. The 4-bit code or 5-bit code is used for duct-type unit only (including multi duct-type unit and 1-to-1 duct-type unit).
- 3) When the “setting of control mode” is “L”, the function dial-up for “setting of memory mode” and “setting of master / slave indoor unit” will be disabled. When the “setting of control mode” is “I”, this function dial-up setting is enabled.
- 4) The dial-up switch shall be put to position correctly, and shall not be put to middle position. Dialing of the switch to “ON” position indicates “0” and the dialing to opposite direction indicates “1”.
- 5) After dialing up, please mark the address code of the unit(√).

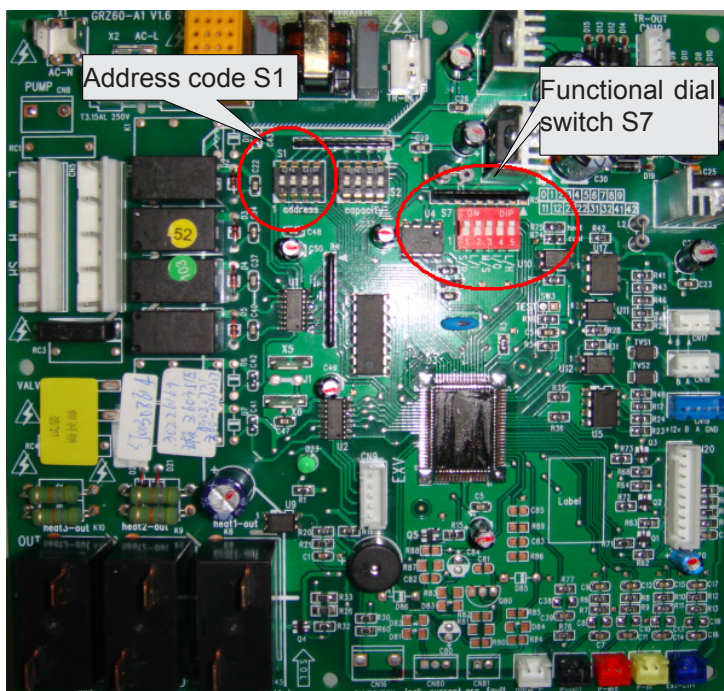

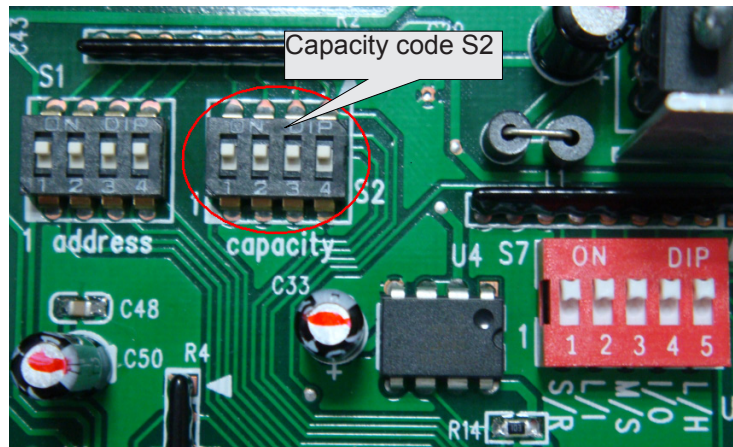

Mainboard of 5-bit functional dial-up

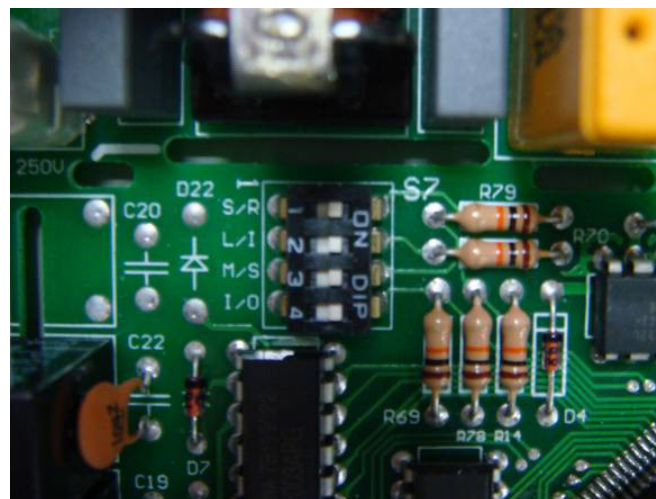
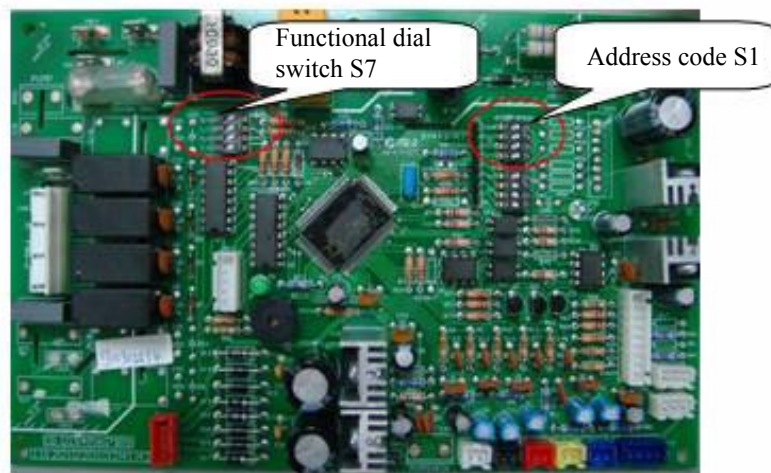

Mainboard of 4-bit functional dial-up



### 7.4.2 Address code

Address dial-up must be set for the multi indoor units; otherwise the abnormal communication will be caused to the unit. The address code has 4-bit dial-up in total. The highest address is 16 and the lowest address is 1.

**NOTES!**

To use multiple indoor units in parallel, make sure to change the setting of address code before installation and guarantee that the address code of each indoor unit must be different (The address code is located on the mainboard of indoor unit). If wired controller is used, make sure to dial the address code of wired controller to the position same as the address code on corresponding indoor unit. (The address code of wired controller is located on the back of wired controller)

◆ Below is factory default setting:

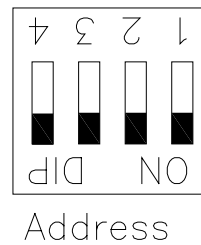

The default setting of address dial-up code is 0000 and the address is 1 (See above for the position of dial lever).

◆ Dial-up Value

The dial-up value of address code is set in binary system. The dial-up value is “0” when the lever is dialed to “ON” end; the dial-up is “1” when the lever is dialed to numerical end on opposite side. For number 4~1 on the address code, the dial-up #4 refers to high bit and the dial-up 1# refers to low bit.

4-bit	3-bit	2-bit	1-bit	Address
0	0	0	0	1
0	0	0	1	2
0	0	1	0	3
0	0	1	1	4
0	1	0	0	5
0	1	0	1	6
0	1	1	0	7
0	1	1	1	8
1	0	0	0	9
1	0	0	1	10
1	0	1	0	11
1	0	1	1	12
1	1	0	0	13
1	1	0	1	14
1	1	1	0	15
1	1	1	1	16

Example 1: If the dial value is “0111”, this represents that the serial number is “8”, the pins 1, 2 & 3 of the dial switch are dialed to the opposite end of “ON”, and the pin 4 is dialed to “ON”.

Example 2: If the dial value is “1010”, this represents that the address is “11”, the pins 2 & 4 of the dial switch are dialed to the numerical end, and the pin 1 & 3 are dialed to “ON”.

Refer to the following figure.

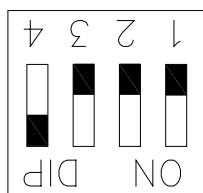

Address

Address 8, dial-up value 0111

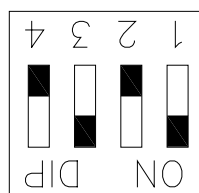

Address

Address 8, dial-up value 1010

### 7.4.3 Capacity Code

On the mainboard of indoor unit, two 4-bit DIP switches are used to distribute the address and capacity of indoor units. The 4-bit DIP switch (marked with “capacity” below) used for setting the capacity of indoor units is factory set before shipment of indoor unit, while it is covered by sealant, so that it cannot be changed by the user.

◆ Below is factory default setting:

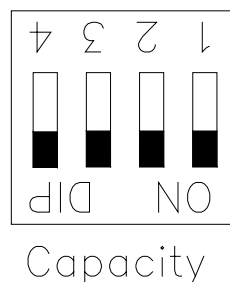

Capacity

The default Capacity dial-up is the maximum capacity of indoor unit. As shown above, the capacity is (See above for the lever position)

◆ Dial-up Value

The dial-up value of capacity code is set in binary system. The dial-up value is “0” when the lever is dialed to “ON” end; the dial-up is “1” when the lever is dialed to numerical end on opposite side. For number 4~1 on the capacity code, the dial-up #4 refers to high bit and the dial-up 1# refers to low bit.

Dial-up Table (4-bit Dial-up Switch)				
4-bit	4-bit	4-bit	1-bit	Capacity
0	0	0	0	20
0	0	0	1	25
0	0	1	0	30
0	0	1	1	35
0	1	0	0	40
0	1	0	1	45
0	1	1	0	50
0	1	1	1	60
1	0	0	0	224
1	0	0	1	70
1	0	1	0	80
1	0	1	1	90
1	1	0	0	100
1	1	0	1	112
1	1	1	0	140
1	1	1	1	280

# ENGINEERING DEBUGGING

## ENGINEERING DEBUGGING

### 1 NECESSITY OF ENGINEERING DEBUGGING FOR VRF UNITS

Different from common units, VRF units has high requirements of design. And also, during engineering installation, the factors which can affect the normal running of the system easily occur, such as impurity and water. Due to complexity of design and installation as well as requirements of high accuracy of system control, debugging must be conducted after finish of the engineering installation. The units can be used after the debugging passes.

### 2 ILES AND TOOLS FOR ENGINEERING DEBUGGING

#### 2.1 Tools

Inner hexagon Spanner	Digital Display Thermometer
Monkey wrench	Sound meter
Phillips screwdriver	Split-core type meter
Slotted screwdriver	Digital multimeter
Vacuum Pump	Ammeter
Electric Scale	Calculagraph
Pressure Gage	Standing ladder
Anemoscope	Gree portable debugger (CE40-24/E), or debugging software and data wire

There are two kinds of debugger for Gree VRF units. One is portable debugger and the other is the computer with exclusive software. Both of them are exclusive and shall be applied to manufacturer.

Note: the model of Gree portable debugger is CE40-24/E

Both two kinds of debuggers can inspect and debug the required parameters. The only difference between them is that the portable debugger can't display parameters of all indoor units and storage or display history data while the PC with exclusive software can do such things. (Please refer to corresponding instruction for specific operation methods).

#### 2.2 Debugging Files

In order to record the events of installation and debugging for the unit, make sure that the following files are complete: Confirmed plan for debugging, cahier, personnel for debugging, appearance inspection record of the system, debugging data record, debugging report, etc. The reference form sets forth in attached list.

## 3 STEPS OF ENGINEERING DEBUGGING

### 3.1 Preparation before Debugging

#### 3.1.1 Integral Debugging Plan

Before debugging, acquire information of debugging scheduling, total workload of debugging, factors which may affect the debugging, required human and material resources. Related responsible person shall make the debugging plan.



### 3.1.2 Members of Debugging

Members of debugging include aftersales debugging personnel and installation personnel, etc.

All members of debugging shall take relative professional training before debugging of the unit. Group these people according to practical situation. Professional of debugging and assistant are essential for each group.

### 3.1.3 Preparation of Tools and Equipments

a. Check if the following tools or equipments are complete before debugging.

Inner hexagon Spanner	Digital Display Thermometer
Monkey wrench	Sound meter
Phillips screwdriver	Split-core type meter
Slotted screwdriver	Digital multimeter
Vacuum Pump	Ammeter
Electric Scale	Calculagraph
Pressure Gage	Standing ladder
Anemoscope	Gree portable debugger (CE40-24/E), or debugging software and data wire

b. Check if the software is correct before debugging.

Debugging of Gree VRF units applies exclusive debugging software or portable debugger which are provided by Gree, or the units can't be effectively debugged.

c. Check if all required files and recorded data are complete.

## 3.2 Inspection before Debugging

### 3.2.1 Inspection of Installation Environment

Inspection of installation environment includes: heat exchange environment of the unit, electromagnetic radiation components, etc, which shall be in accordance with related national electric standards. If there is any thing which can't conform to installation standards, make record in time for analysis during debugging.

### 3.2.2 Appearance Inspection

Inspect appearance to check if the installation of pipeline conforms to standards, if insulation work of discharge pipe is good and if communication wire can meet requirements of installation standards.

The refrigerants pipeline shall be installed vertically and the inclination degree of branch pipe shall be within the specified range. If there is any thing which can't conform to installation standards, make record in time for analysis during debugging.

Refrigerants pipeline and condensate discharge pipe can't be directly exposed. Repair it if there is any pipe exposed or serious loss will be caused.

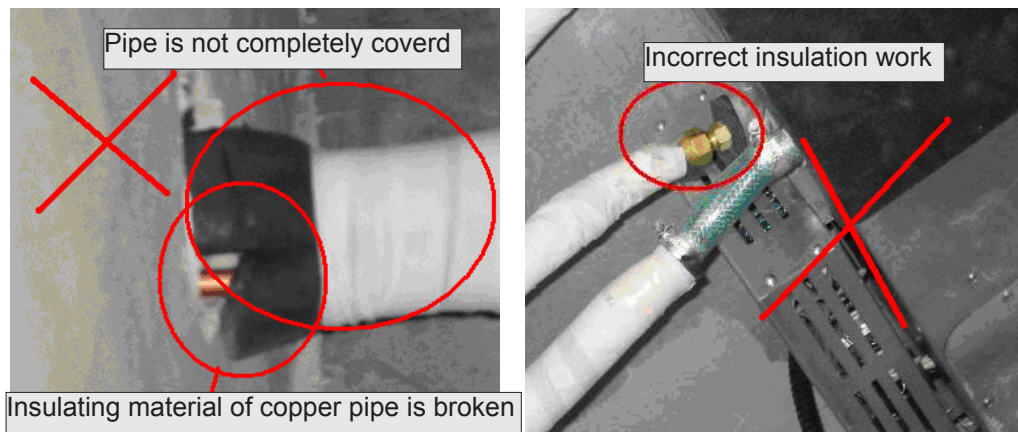

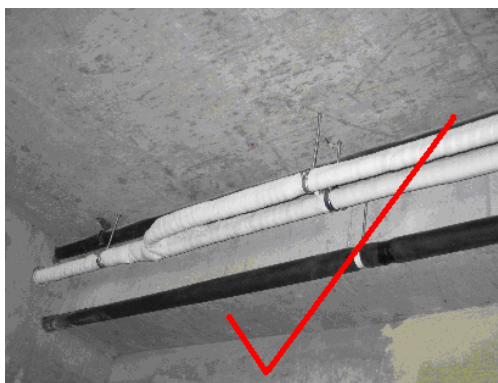

### 3.2.3 Inspection of Refrigerating System

1) Before debugging, make sure that cut-off valve of each module is in the maximum opening angle and in the meantime, check if there is any mark of oil on the valve. If there is, inspect the valve immediately, and if confirm that there is any leakage, stop the debugging immediately which can be resumed again after the problem of leak has been solved.

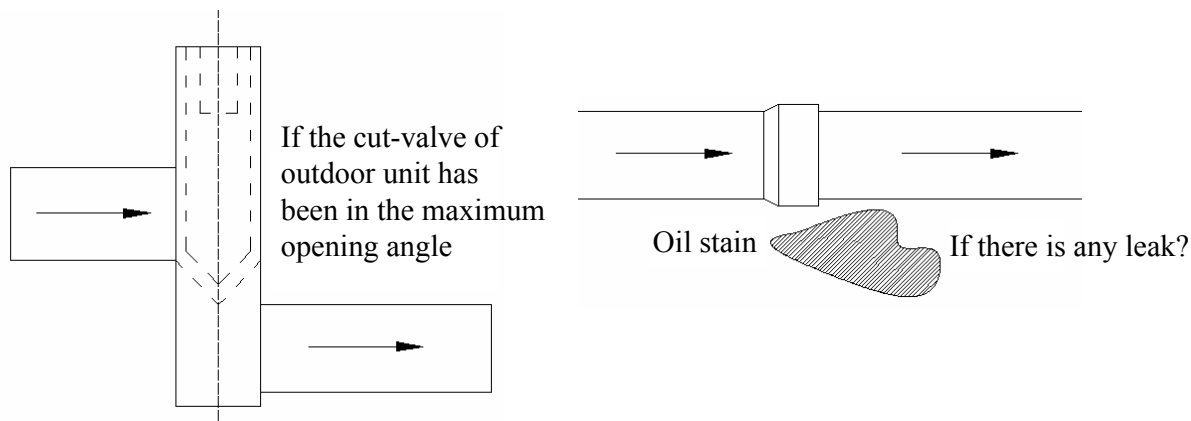

Note: if there is only one outdoor module, the oil balance valve can't be opened, and cut-off valve of gas pipe and cut-off valve of liquid gas pipe need to be opened.

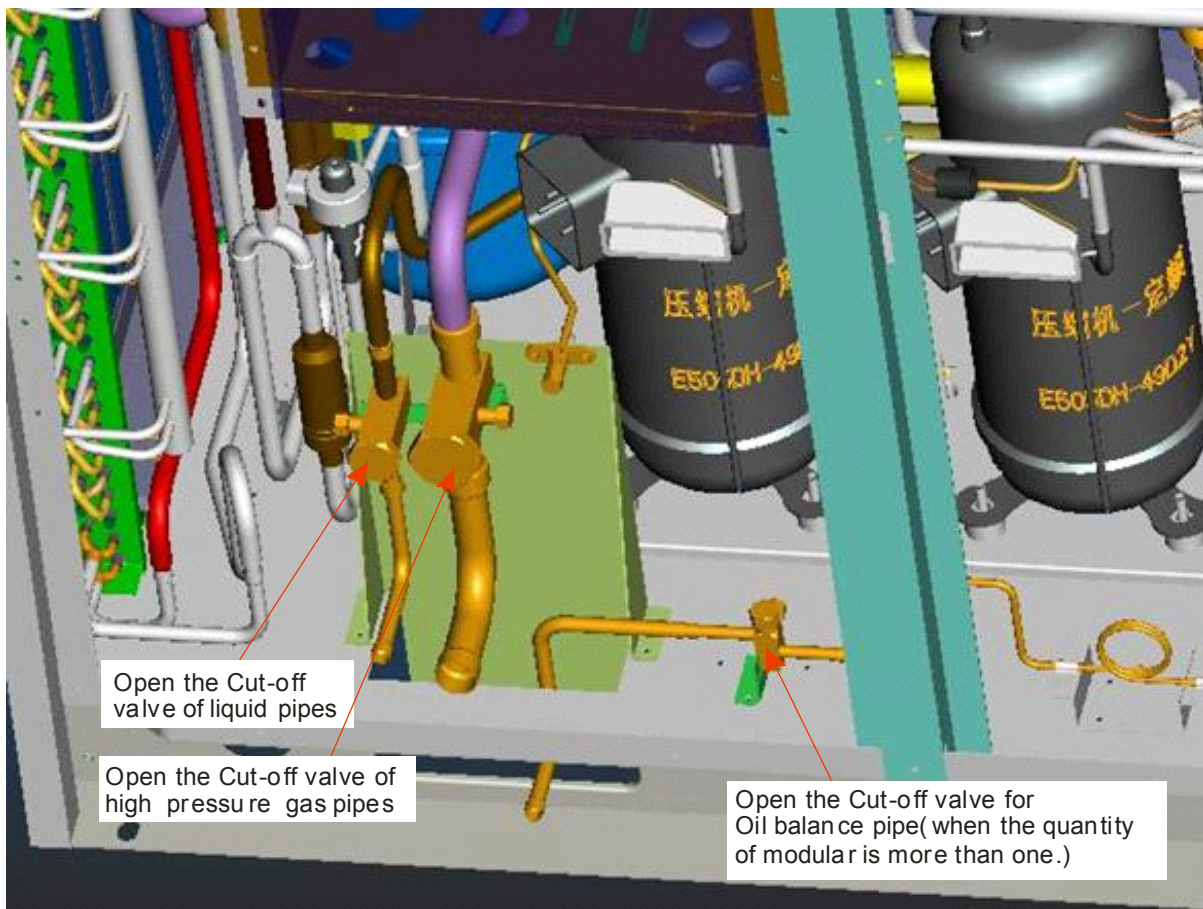

2) Check if the refrigerant in the system is normal by manometer connecting liquid pipe and valve of low pressure gas pipe.

In normal conditions, if the system has been stoodby for more than 3 min, the high pressure and low pressure of the system will be in balance. The difference between saturation temperature corresponding to pressure value and ambient temperature (the temp is indoor temp or outdoor temp, whichever is the higher) can't be more than 5°C. Note: make sure that the system is not started up or it has been energized for more than 10 min since last stop of running (The lower outdoor ambient temp is, the longer time that the pressure value stabilizes), or the high pressure value of the system will be much higher than the ambient temp or the low pressure of the sytem will be much lower than the ambient temp)

Eg:

If outdoor ambient temp is 30°C, indoor ambient temp is 28°C, high pressure value of the system is 28°C and low pressure value is 27°C, all differentials between outdoor ambient temp and the others are within 5°C which means the standby pressure of the system is normal.

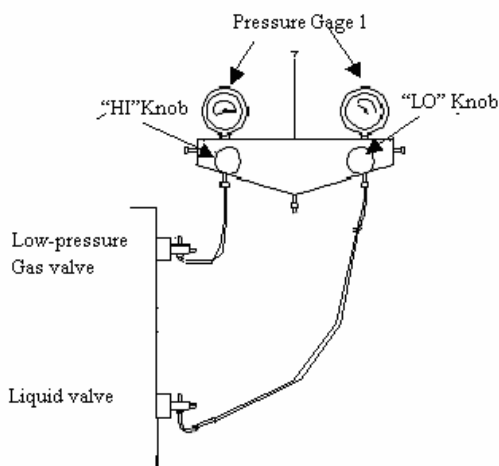

### 3.2.4 Inspection of Electrical System

1) Check if there is any electromagnetic interference, mill dust and acid and alkaline gas around the units.

a. Power supply of the units can't work with equipments with inverter or close to the equipment with strong electromagnetic interference. If there is any electromagnetic interference, make record in time, and if the situation gets worse, the installation site must be relocated or corresponding measures must be taken.

b. Prevent acid or alkaline gas or liquid from corroding cables of the units.

2) Inspection of Appearance of Power Cord

Inspect if power cords of units are installed according to requirements of manufacturer, if the wire is firmly connected with wiring terminal and if there is any conducting wire exposed in other joints of the power cords.

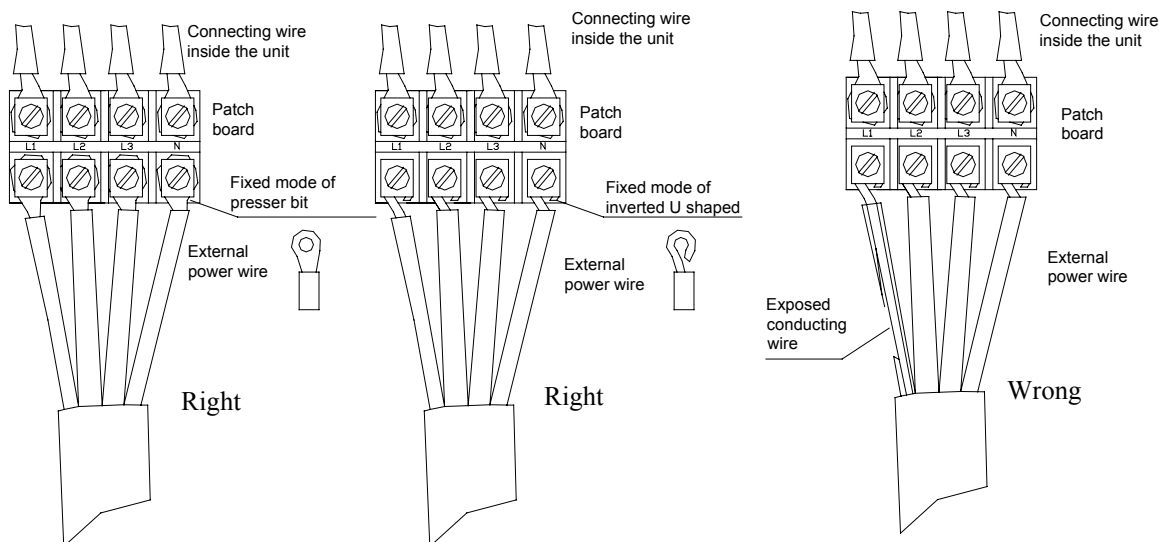

3) Inspection of Power Supply Capacity of the Units

Due to the working current changes greatly under different conditions which is much more than rated current, the electric network is unstable and power factor decreases, the capacity of power supply shall be 1.5~1.8 times of rated power.

4) Selection and Usage Mode of Air Switch and Fuse-link

a. For commercial air conditioners, independent air switch, fuse-link and other similar components must be installed, the selection and usage mode of which shall be proper.

Note:

a1. Air switch can be protection for overload and short circuit. The ability of breaking current and response speed is not as good as fuse-link but it can be manually reset after it is operated.

a2. Fuse-link just can be protection for short circuit of the units. Its ability of breaking current and response



speed are good but it shall be replaced after it is operated.

b. The selection of air switch can refer to rated current of the complete unit, 2.25 times of which shall be close to the current of air switch.

5) Inspection of Components inside the Electric Box ( De-energization )

Firstly, inspect if the components inside the electric box dropped off during transportation and then check if there is any loose components or wiring. For huge units, the terminal of patch board and wiring terminal shall be screwed up again and after the units have been running for 2 months, screw them once again. Due to the auxiliary contact of AC contactor has been debugged in factory, it can't be disassembled.

6) Cautions of Laying the Power Cord

The trunking and flame-retarded PVC pipe shall be used when laying the power cord and for huge-sized power cord, the cable supporting system shall be used. Don't expose the power cord under sunshine or rain.

a. Relationship of Power, Current and Width of Cable

Selection of Cable

Category: Rubber, PVC

Width of Cable: Firstly, figure out the distance between electric cabinet and the unit and then the total length of cable. Finally, check the  $\Omega/km$  according to the model of the cable to determine the width of cable.

		Width of Cable (mm <sup>2</sup> )					
Distance(m) Max.Current(A)	0~15	15~30	30~50	50~75	75~100	100~125	125-150
10	2.5	2.5	2.5	4	4	6	6
20	4	4	4	6	6	10	10
30	6	6	6	6	10	10	10
40	10	10	16	16	16	16	25
50	16	16	16	25	25	25	35
60	25	25	25	25	25	25	35
70	35	35	35	35	35	35	50
80	35	35	35	35	50	50	70
90	35	35	50	50	50	70	70
100	50	50	50	50	70	70	70
120	50	50	50	70	70	70	95
140	50	70	70	70	95	95	95
160	70	70	70	70	95	95	95
200	95	95	95	95	95	95	120
240	120	120	120	120	120	120	150
300	150	150	150	150	150	150	150
330	185	185	185	185	185	185	185
400	240	240	240	240	240	240	240
500	300	300	300	300	300	300	300
600	400	400	400	400	400	400	400

b. Ground Wire of the Unit

For safety, the unit must be reliably earthed and the earthing device can't withstand the pulling force of mechanism

$$S=D \quad D \leq 16$$

$$S=D/2 \quad D < 16$$

3.2.5 Inspection of Communication System

1) Inspect the following contents before debugging.

If communication among mainboard of outdoor modules is normal

If qty code and address code of outdoor modules are correct

If address codes of patch boards of outdoor modules are correct

If connection between indoor unit and patch board is correct

If qty of indoor units under every patch board is less than 16?

If connection among indoor units air is correct?

If address codes of indoor units are correct?

If address code of wired controller of every indoor unit is the same with the address code of corresponding indoor unit?

2) Communication wire shall be independently paved by flame-retarded PVC pipe and can't in the same trunking with power cord. The parallel distance between communication wire and strong current wire shall be greater than 20 cm.

3) Control wires of all electric expansion valves and power cord of 4-way valve shall be reliably connected to the mainboard of corresponding indoor unit. If there is any abnormality, handle it immediately. The debugging can be resumed after the problem has been solved.

3.2.6 Before debugging, install and get familiar with the software for debugging.

### 3.3 Debugging

#### 3.3.1 Cautions:

1) Before the debugging starts, make sure that the units have been energized for more than 8 hours so that the compressor can be preheated. Touch the unit by hand to check if the preheating is normal, and if it is, debugging can be started or the compressor is likely to be damaged. The debugging must be conducted or under guidance of the professional.

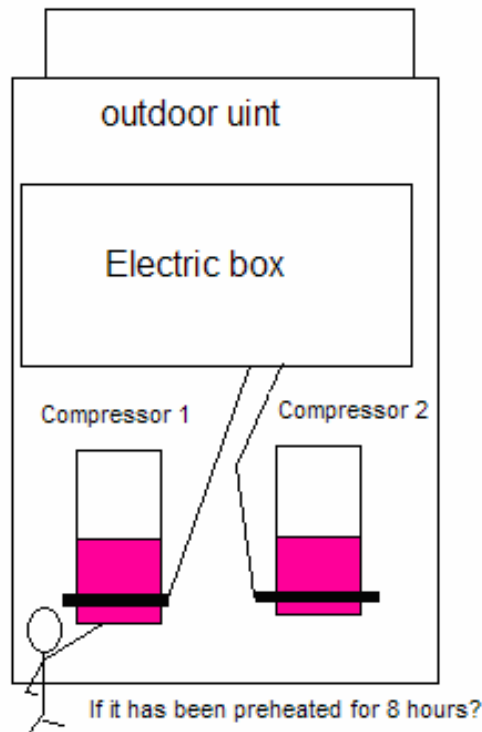

2) When the debugging is started up, choose proper running mode according to the ambient temperature.

When ambient temp is above 20°C, the debugging mode shall be complete cooling mode.

When ambient temp is lower than 20°C, the debugging mode shall be complete heating mode.

3) When debugging, the system will start one indoor unit every 5 min until all indoor units have been started up.



### 3.4 Debugging of Cooling Mode

Step1: make sure that the compressor has been preheated for over 8 hours before first startup of it.

Step 2: Connect monitoring instrument of debugging.

Step 3: After the monitoring instrument has been installed, check if the communication of data is normal, if all indoor units and wired controllers can be viewed on monitoring software and if there is any repeated code or wire dropped off.

When it is normal, the address of wired controller shall be corresponding to address of indoor unit, which is shown as Fig. A.

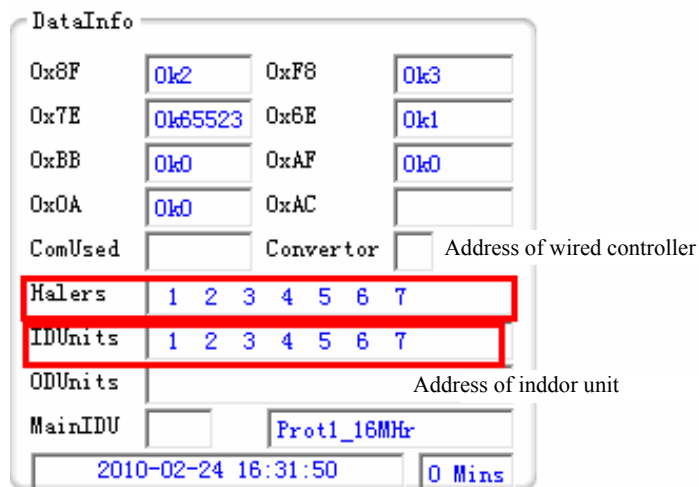

Fig.A

When there is repeated address code of indoor unit, the display of wired controller is normal, but the indoor unit with repeated address code can't be displayed as shown in Fig B

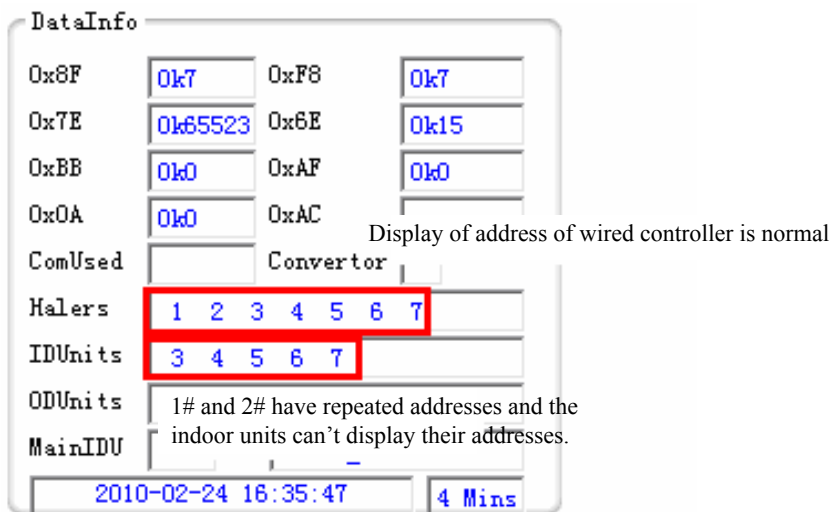

Fig B

When address of wired controller is the same with that of other wired controller, or it is disconnected, the address can't be display as shown in Fig C.

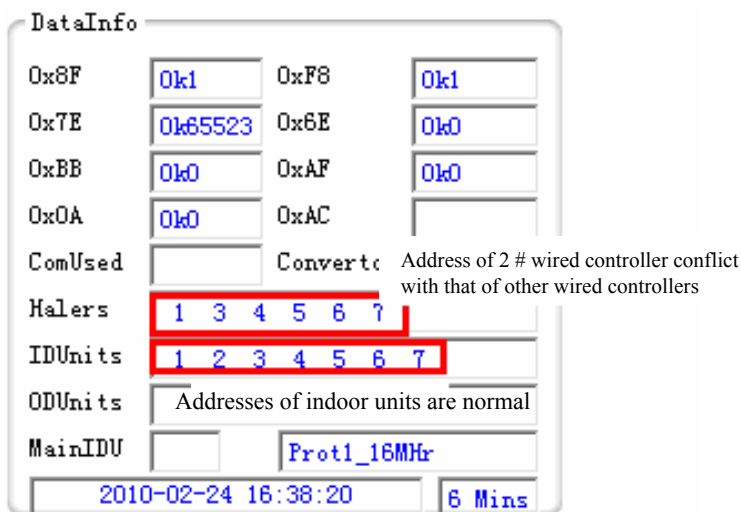
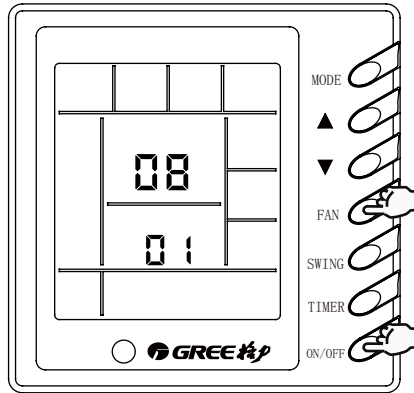

Fig C

### Search and Setting Methods of Address of Z6035F Wired Controller

When the unit is turned off, press buttons “Fan” and “ON/OFF” simultaneously, and the address no. of the display panel will be shown on where setting temperature is shown on display panel. Address code of indoor unit will be shown on where the ambient temperature is shown on display panel and address code of patch board which connects main indoor unit will be displayed on where the setting temperature is shown on display panel.



### Search and Setting Methods of Address of ZX6045 Wired Controller

Search of address of wired controller: When the unit is turned off, press buttons “Function” and “Mode” simultaneously and the address no. of this wired controller will be displayed on display panel.

Setting of Address of Wired Controller: When the unit is turned off, press buttons “Function” and “Mode” simultaneously for 5s, and the address no. will be displayed and blink on display panel. Press “▲” and “▼” to adjust the address code( between 1-16). Then press button “Confirm/Cancel” to confirm it.

Search and setting of address of wired controller are as follows:

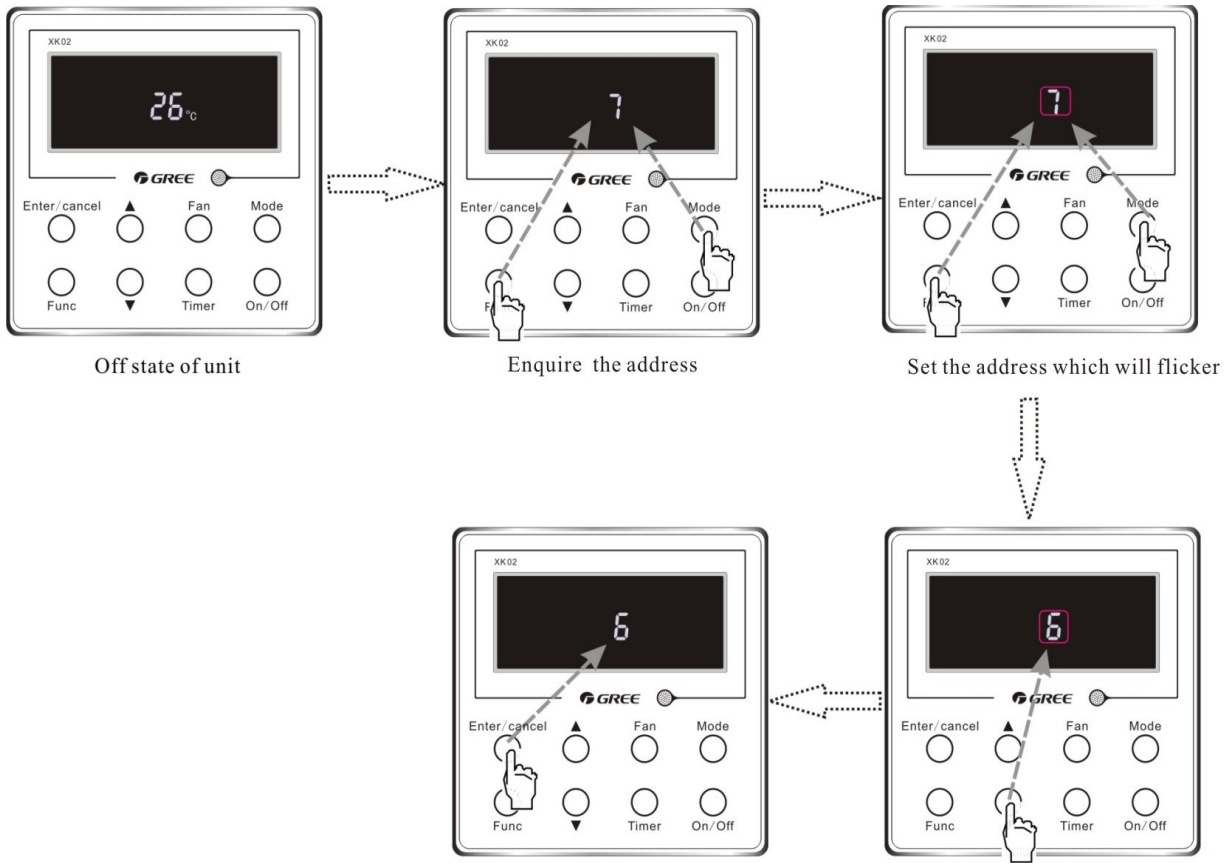

Press “Enter/cancel” to make a confirmation

Press ▲ or ▼ to adjust the address number

Step 4: Make sure that the communication is normal, and then record each parameter. Finally, start one indoor unit every 5 min.

Step 5: According to reference value of parameter, check if there is any abnormal parameter. If there is, find the cause and solve it. Then, start the debugging again and if everything is normal, measure and record each parameter after 30min.

Step 6: Record each parameter when the capacity is just shifted and after 30min, measure and record these parameters again. Finally, save the data of monitoring software and the debugging is finished. If there is any abnormality, find the cause and solve it. Then, start the debugging again

Note: during debugging, listen carefully for the sound from indoor and outdoor fans as well as the compressor to check if they are normal.

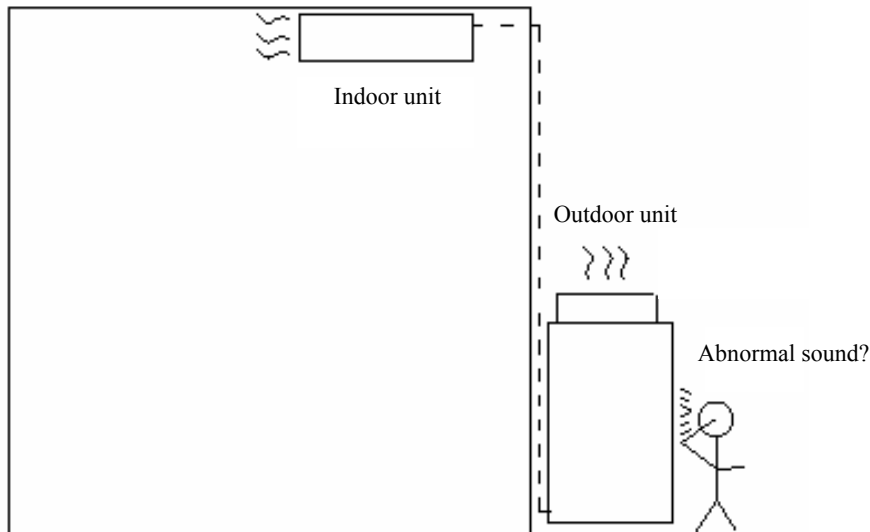

### 3.5 Running of Heating Mode

If environmental conditions are proper, after the debugging of cooling mode has been finished, the system can be shifted to heating mode directly. The system will run with max capacity of indoor unit and with min. capacity of indoor unit separately. The debugging method is as cooling mode.

Note: if the environmental conditions are not proper for running of cooling mode, start the debugging of heating mode directly which is as the debugging of cooling mode.

**3.6 When the debugging is finished, sort out and save the data. Record the trouble and troubleshooting during the debugging for future reference. Then, make a debugging report and turn over it to users.**



## 4. MAIN PARAMETERS AND REFERENCE VALUES FOR DEBUGGING

Reference Value of the Debugging Parameters for the Pdm-NaB Series Modular DC Inverter VRF System

No.	Debugging Items	Parameter Description	Unit	Reference Value	Remarks		
1	System Parameters	Outdoor Unit	Outdoor ambient temperature	°C	—		
2			Discharge pipe temperature of inverter compressor	°C	<ul style="list-style-type: none"> <li>●During the startup and operation of the compressor, the normal temperature of the discharge pipe or the top shell is between 70°C~85°C and the normal heating temperature is between 65°C~75°C, both of which are at least 10°C higher compared with the saturated temperature of the corresponding system high pressure.</li> <li>●On condition that the inverter compressor runs but the fixed frequency compressor stops, the shell top temperature of the fixed frequency compressor should be a little higher than that of the ambient which is very close to that of its discharge pipe.</li> </ul>		
3			Shell-top pipe temperature of inverter compressor	°C			
4			Discharge pipe temperature of compressor with fixed frequency 1	°C			
5			Shell-top pipe temperature of compressor with fixed frequency 1	°C			
6			Discharge pipe temperature of compressor with fixed frequency 2	°C			
7			Shell-top pipe temperature of compressor with fixed frequency 2	°C			
8			Inlet pipe temperature of the heat exchanger	°C		<ul style="list-style-type: none"> <li>●Under the cooling mode, the inlet pipe temperature of the heat exchanger should be at least 20°C higher than that of the outlet pipe.</li> <li>●Under the heating mode with the outdoor ambient temperature below 10°C, the temperature of the inlet pipe of the heat exchanger should be 1°C higher than that of the outlet pipe; while if the outdoor ambient temperature is above, the temperature of the inlet pipe should be 3°C~10°C higher.</li> </ul>	
9			Outlet pipe temperature of the heat exchanger	°C			
10			Mid pipe temperature of the heat exchanger	°C		—	NA
11							
12			System high pressure	°C	The temperature under the normal high pressure should be among 20°C~55°C. With the change of the ambient temperature and the system running capacity, this temperature should be 10°C~40°C higher than the ambient temperature. The higher the ambient temperature is, the smaller the temperature difference between them is.		
13			System low pressure	°C	<ul style="list-style-type: none"> <li>●Under the system low pressure of the cooling mode, the temperature should be among -15°C~12°C, with the max. temperature 15°C lower than the indoor ambient temperature and min. temperature close to the outdoor ambient temperature.</li> <li>●Under the system low pressure of the heating mode, the temperature should be -25°C~10°C, which is about 9°C lower than outdoor ambient temperature.</li> </ul>		



Reference Value of the Debugging Parameters for the Pdm-NaB Series Modular DC Inverter VRF System

No.	Debugging Items	Parameter Description	Unit	Reference Value	Remarks	
14	System Parameters	Opening level of the electronic expansion valve of the outdoor unit	PLS	<ul style="list-style-type: none"> <li>●480PLSU; Under the cooling mode, the opening level of the electronic expansion valve should keep at 480PLSU consistently.</li> <li>●Under the heating mode, the opening level of the electronic expansion valve should be among 100~480PLS</li> </ul>		
15		Running frequency of the inverter compressor	Hz	Between 30Hz~90Hz		
16		Inverter compressor current	A	According to the different running frequency and load, the corresponding current varies among 7A~20A.		
17		IPM module fin temperature	℃	The normal temperature is lower than 95℃ and 40℃ will be displayed when the temperature is lower than 40℃.		
18		Driving bus voltage	V	The normal bus voltage is 1.414 times of that of power supply. E.g. the voltage of the three-phase power supply is 390V, then the bus voltage after rectification should be $390v \times 1.414 = 551v$ with the tolerance of 15v.		
19		Indoor Unit	Ambient temperature of the indoor unit	℃	—	
20			Inlet pipe temperature of the heat exchanger of the indoor unit	℃	<ul style="list-style-type: none"> <li>●According to the different ambient temperature, the inlet pipe temperature is 1℃~7℃ lower than that of the outlet pipe temperature under the cooling mode.</li> <li>●Under the heating mode, the inlet pipe temperature is 10℃~20℃ lower than that of the outlet pipe temperature of the same indoor unit.</li> </ul>	
21			Outlet pipe temperature of the heat exchanger of the indoor unit	℃	<ul style="list-style-type: none"> <li>●Under the cooling mode, the midway pipe temperature is some 0℃~5℃ lower than that of the outlet pipe temperature.</li> <li>●Under the heating mode, the midway pipe temperature is between those of the inlet and outlet pipes.</li> </ul>	
22			Midway pipe temperature of the heat exchanger of the indoor unit	℃		
23			Opening angle of the electronic expansion valve of the indoor unit	PLS	Automatic adjustment between 100~480PLS	
24	Communication Parameters	Communication Data	—	Real-time check through the monitoring software is realizable to the data from the main board and wired controller, without occurrence of any malfunction.		
25	Drainage System	—	—	The drainage of the indoor unit goes smoothly and thoroughly; no condensate water is accumulated in the drain pipe; and no water drips directly along the base frame of the unit.		
26	Others	—	—	The compressor and fan motor of the outdoor/indoor unit run without any abnormal sound and any malfunction.		

## 5 COMMON TROUBLES DURING DEBUGGING

### 5.1 Communication

Abnormal communication is the main and common trouble in communication system which mainly consists of the following groups.

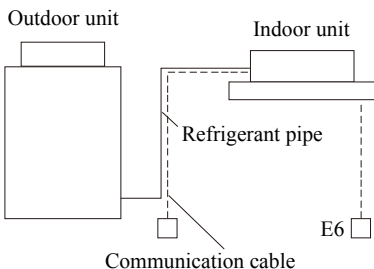
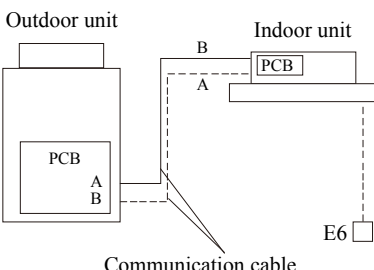
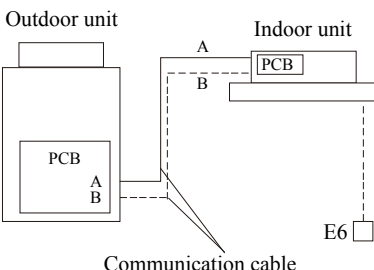
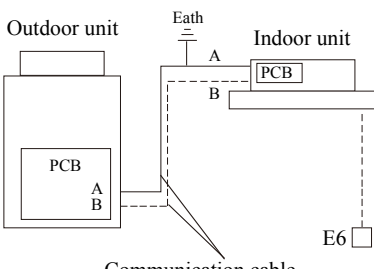
S/N	Class	Trouble	Possible Cause	Troubleshooting	
1	Abnormal communication between indoor unit and outdoor unit	"E6" communication error codes are displayed on all indoor and outdoor units.	<p>Communication wire between indoor and outdoor unit is not connected.</p> 	Check if communication wire is connected.	
2			<p>The polarities of communication wire connecting indoor and outdoor units are not inconsistent.</p> 	Exchange the polarities of plugs of communication wire.	
3			<p>The communication wire connecting indoor unit to outdoor unit is short circuit.</p> 	Check it with universal meter and if it is short circuit, replace the communication wire	
4			Address of indoor unit, wired controller or outdoor unit is not correctly set.	Check if their addresses are set correctly.	
5			Addresses of main board of outdoor unit or patch board are not correctly set.	Check if their addresses are correctly set.	
6			Communication between indoor unit and outdoor unit is not continuously	<p>The communication wire connecting outdoor unit and indoor unit is short circuit or it contacts metal when it is damaged</p> 	Check it with universal meter and if it is short circuit, replace the communication wire. Separately measure the two polarities of communication wire and check if it is shorted to earth.
7			The ground wire which shield communication wire is not efficiently earthed.	Efficiently connect the ground wire.	

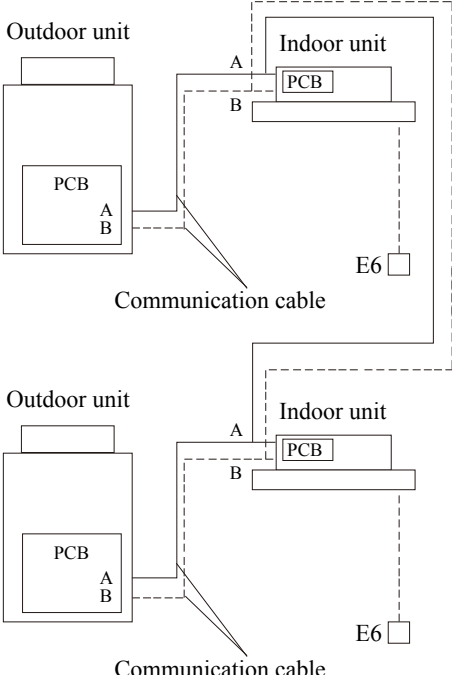
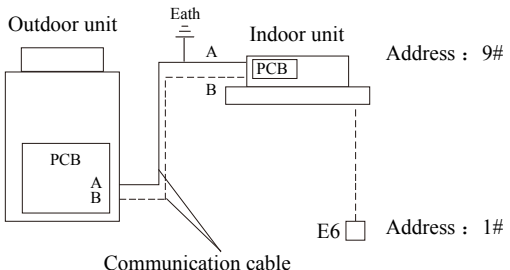
8	Abnormal communication between indoor unit and outdoor unit	Communication between indoor unit and outdoor unit is not continuously	<p>Communication wires of different patch boards in the side of indoor units are crossed</p> 	Check if the communication wires of different patch boards are wrongly connected.
9	Communication of a part of indoor units is abnormal.	"E6" is displayed in one or a few of indoor unit(s).	<p>Address code of that indoor unit is not the same with that of wired controller connected.</p> 	Check if address code of that indoor unit is the same with that of wired controller connected.
10	Communication of a part of indoor units is abnormal.	For some indoor unit, the data is not always displayed on wired controller or the unit is on and off alternately.	There are repeated codes among main boards of indoor units or wired controllers.	Check if there are repeated codes among indoor units or wired controllers.
11		"E6" are displayed on all indoor units which connect a same patch board.	Communication wire between that indoor unit and the wired controller is short circuit.	Check it with universal meter and if it is short circuit, replace the communication wire. Separately measure the two polarities of communication wire and check if it is shorted to earth. And if it is, replace the communication wire.
12			There is repeated address code of patch board.	Check the code again.
13			The communication wire of the module of that patch board is not correctly connected with other modules.	Check communication wires among modules and the code again.

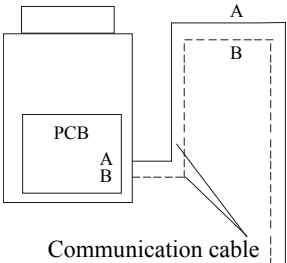
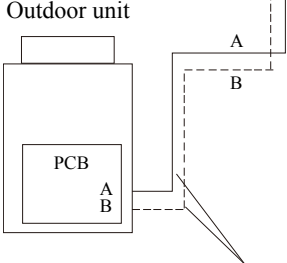

14			Address code and qty code of mainboard of outdoor unit are not correctly set.	Check and reset them.
15	Communication among outdoor modules is abnormal.	“E6” error code will be displayed on outdoor module as well as the indoor units which are connected by this patch board.	<p>Communication wire among outdoor units is not correctly connected.</p> <p>Outdoor unit</p>  <p>Communication cable</p> <p>Outdoor unit</p>  <p>Communication cable</p>	Replace communication wire.

5.2 System

5.2.1 Discharge temp of system is abnormal.

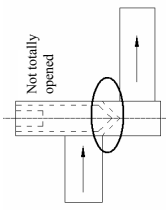
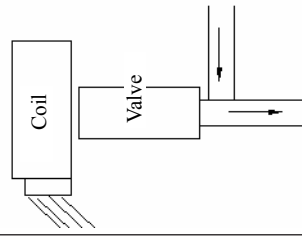
Note: the discharge temp mentioned above means the temp of discharge pipe of compressor or the temp of the top of compressor.

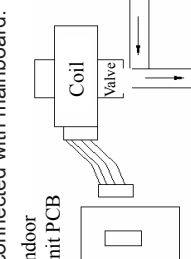
S/N	Class	Trouble	Possible Cause						Troubleshooting
			First-level reason		Second-level reason		Third-level reason		
			Description of Cause	Method of Confirmation	Description of Cause	Method of Confirmation	Description of Cause	Method of Confirmation	
1			 <p>1. Cut-off valve of outdoor unit is not opened to the position, which can allow maximum flow.</p>	---	---	---	---	Manually check	Reopen the cut-off valve to the place where allows the maximal flow.
2	Discharge temp is abnormal	Discharge temp is superhigh	<p>2. Electric expansion valve does not correctly operate</p>	<p>In cooling mode, when electric expansion valve is opened to 480PLS, outlet temp of coil pipe of indoor unit is greater than inlet temp for over 15 °C. In heating mode, when electric expansion valve is opened to 480PLS, inlet temp of coil pipe of indoor unit is lower than ambient temp for over 10 °C.</p>	 <p>2.1 Coil of electric expansion valve is loose or drops off</p>	<p>De-energize and then energize the indoor unit, check if the electric expansion valve is reset by touching pipeline and hearing the voice. If it is reset, it is normal.</p>	---	Manually check	Install and fix the coil of electric expansion valve again.

S/N	Class	Trouble	Possible Cause				Troubleshooting		
			First-level reason		Second-level reason			Third-level reason	
			Description of Cause	Method of Confirmation	Description of Cause	Method of Confirmation		Description of Cause	Method of Confirmation
3			<p>In cooling mode, when electric expansion valve is opened to 480PLS, outlet temp of coil pipe of indoor unit is greater than inlet temp for over 15 °C. In heating mode, when electric expansion valve is opened to 480PLS, inlet temp of coil pipe of indoor unit is lower than ambient temp for over 10 °C.</p>	2.2 Electric expansion valve is abnormal.	De-energize and then energize the indoor electric expansion valve is reset by touching pipeline and hearing the voice. If it is reset, it is normal.	<p>2.2.1 Control wire of expansion valve is not connected with mainboard.</p> 	Manually check	Connect control wire of electric expansion valve.	
4	Discharge temp is abnormal	2. Electric expansion valve does not correctly operate	<p>2.2 Electric expansion valve is opened to 480PLS, inlet temp of coil pipe of indoor unit is lower than ambient temp for over 10 °C.</p>	2.3 Electric expansion valve is abnormal.	Not the reason mentioned above	<p>2.2.2 Control wire of expansion valve connected with mainboard is damaged.</p> 	Manually check	Repair or replace control wire of electric expansion valve	
5						2.3.1 Foreign objects inside the system affect it.	—	Clean and blow the system to clear the foreign objects and meanwhile replace the valve body.	
6						2.3.2 Valve body is abnormal.	—	Replace the valve body.	

S/N	Class	Trouble	Possible Cause						Troubleshooting
			First-level reason		Second-level reason		Third-level reason		
			Description of Cause	Method of Confirmation	Description of Cause	Method of Confirmation	Description of Cause	Method of Confirmation	
7				4.1 Liquid pipe of the system is blocked.	Along the flow direction of refrigerants, the difference of local temperatures is great or there is frost on partial pipe.	—	—	Replace and weld pipeline again.	
8			Discharge temp of the system abnormally increases and the low pressure is too low.(Judge according to reference standard).	4.2 Low pressure gas pipe of the system is blocked.	Along the flow direction of refrigerants, the difference of local temperatures is great or there is frost on partial pipe.	—	—	Replace and weld pipeline again.	
9			4.Pipeline of the system is blocked	Discharge temp of the system abnormally increases and the low pressure is too low.(Judge according to reference standard).	4.3 The connecting pipe of indoor unit is blocked.	4.4.1 The welding causes block.	Cut the pipe to check.	Replace and weld pipeline again.	
10					4.4.2 There are too many impurities inside the pipeline.	Replace and weld pipeline again.			
11			5. Refrigerants of the system are inadequate.	Discharge temp of the system abnormally increases and the low pressure is too low.(Judge according to reference standard).	5.1 The volume of refrigerants is not calculated or added according to requirements.	—	—	Add refrigerants according to requirements.	
12	Discharge temp is abnormal	Discharge temp is superhigh		6. The type of the refrigerants added is wrong.	Stop the complete unit and check the equalizing pressure of high and low pressures after 20 min. Then, transfer the pressure value to the corresponding saturation temp and compare it with outdoor ambient temp. If the temp difference is more than 5 ℃, it is abnormal.	5.2 Leak of the pipeline causes the insufficiency of the refrigerants.	Check it with leak detector of refrigerants.	—	Handle the leak and vacuumize the pipe again and charge the refrigerants.
13									Release the refrigerants inside the system and recharge the correct refrigerants.
14				7. The inspection of discharge temp sensor is wrong.	—	—	—	—	Replace temp sensor or mainboard.
15				8. Ambient temp exceeds the range for safe running.	—	Ambient temp is more than 48 ℃.	Collect ambient temp on spot.	—	Normal phenomenon.

5.2.2 Abnormal System Pressure

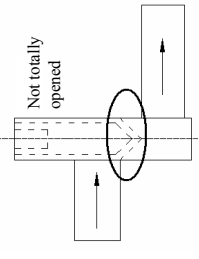
S/N	Class	Trouble	Possible Cause						Troubleshooting
			First-level reason		Second-level reason		Third-level reason		
			Description of Cause	Method of Confirmation	Description of Cause	Method of Confirmation	Description of Cause	Method of Confirmation	
1			 <p>Not totally opened</p> <p>1. Cut-off valve of outdoor unit is not opened to the position, which can allow maximum flow.</p>	---	---	---	Manually check	Open the cut-off valve to the position which can allow maximum flow	
2				2. 1G gas pipe of the system is blocked.	Along the flow direction of refrigerants, the difference of local temperatures is great.	2.1.1 The welding causes block. 2.1.2 There are too many impurities inside the pipeline.	Cut the pipe to check.	Replace and weld pipeline again. Replace and weld pipeline again.	
3	Abnormal system pressure increases.	Discharge pressure abnormally increases.		Discharge temp of the system abnormally increases and the low pressure is too low (Judge according to reference standard).					
4			2. Pipeline of the system is blocked		2.2 Liquid pipe of the system is blocked.	Along the flow direction of refrigerants, the difference of local temperatures is great or there is frost on partial pipe.	---	Replace and weld pipeline again.	
5					2.4 The connecting pipe of indoor unit is blocked.	Along the flow direction of refrigerants, the difference of local temperatures is great or there is frost on partial pipe.	2.4.1 The welding causes block. 2.4.2 There are too many impurities inside the pipeline.	Replace and weld pipeline again. Replace and weld pipeline again.	
6							Cut the pipe to check.	Replace and weld pipeline again.	



S/N	Class	Trouble	Possible Cause						Troubleshooting
			First-level reason		Second-level reason		Third-level reason		
			Description of Cause	Method of Confirmation	Description of Cause	Method of Confirmation	Description of Cause	Method of Confirmation	
7			3. The ambient temp is too high when the unit is running		3.1 Outdoor ambient temp is more than 48 °C when cooling operation. 3.2 Heating operation, actual temp of return air of the indoor unit exceeds 30 °C.	Collect outdoor ambient temp on spot. Collect return air temp on spot.			Normal phenomenon.
8					4.1 Inspection of high pressure transducer is abnormal.	Stop the complete unit and check the equalizing pressure of high and low pressures after 20 min. Then, transfer the pressure value to the corresponding saturation temp and compare it with outdoor ambient temp. If the temp difference is more than 5 it is abnormal.			Normal phenomenon.
9									Replace high pressure transducer
10	Abnormal system pressure	Discharge pressure abnormally increases.	4. Pressure transducer is abnormal.		4.2 High pressure transducer and low pressure transducer are wrongly connected.	When the system is running, check the high pressure of gas pipe and liquid pipe. Then, transfer them to the corresponding temp value which shall be respectively compared with the corresponding temp value detected by system. If the temp difference is greater than 5 there is abnormality.			Exchange these two pressure transducers.
11					5.1 The connection between high pressure switch and mainboard is abnormal.			5.1.1 Pressure switch is not connected with mainboard.	Connect them again.
12			5. High pressure switch abnormally operates.	"E1" code will be displayed after energization of the unit.				5.1.2 Connecting wire between pressure switch and mainboard is abnormal.	Replace the connecting wire.
13					5.2 High pressure switch is damaged.				Replace pressure switch.

S/N	Class	Trouble	Possible Cause						Troubleshooting
			First-level reason		Second-level reason		Third-level reason		
			Description of Cause	Method of Confirmation	Description of Cause	Method of Confirmation	Description of Cause	Method of Confirmation	
14				6.1 Indoor fan abnormally operates.	Manually check	6.1.1 The power cord between motor and mainboard is loose or broken. 6.1.2 Capacitance of motor is not connected or damaged.	Manually check	Reconnect the power cord of motor.	
15				6.2 Outdoor fan abnormally operates.	Manually check	6.2.1 Power cord of fan motor is not effectively connected with mainboard of motor. 6.2.2 Signal feedback line of fan motor is not effectively connected with mainboard of motor.	Manually check	Effectively connect it again	
16					Manually check	6.1.3 The motor is damaged.	Not the reason mentioned above	Replace motor.	
17					Manually check	6.2.3 The mainboard of fan motor is damaged. 6.2.4 The mainboard of fan motor is damaged.	Manually check	Effectively connect it again	
18	Abnormal system pressure	Discharge pressure abnormally increases.	6. Fan abnormally operates. A. In cooling operation, outdoor fan is not running. B. In heating operation, the motor of the indoor unit which is heating is not running.						
19								Replace mainboard of motor.	
20								Replace motor.	
21			7. Volume of refrigerants is too much.	Not the reason mentioned above				Check the volume of refrigerants which needs to be added and then release the surplus refrigerants from cut-off valve.	

## 6 PORTABLE DEBUGGER

### 6.1. Function Introduction

Portable debugger is a set of specialized installation debugging tool for personnel of air conditioner debugging and testing. Its main features include:

1. Monitor various unit parameters and support multiple protocols, with automatic protocol identifying function.
2. Support complete unit debugging mode. Support indoor unit debugging mode of GMV multi VRF series.
3. Possess easy operation and portable features.

Note: Different software support different numbers of protocol.

### 6.2 Display and Button

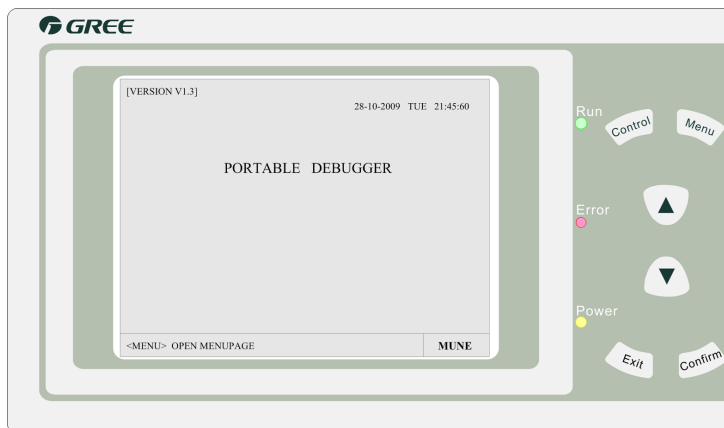

“Power supply” LED (yellow): This LED is light when display panel is energized.

“Malfunction” LED (red): This LED is light when there is communication malfunction (the protocol is not identified).

“Running” LED (green): This LED is light when receiving communication data.

**Control**: It is available in “indoor unit state page”(IDU STATE) (only available in indoor unit of GMV multi VRF series). Long press it (two seconds) to enter “centralized control page”; quick press it to select online indoor unit

**Menu**: Press this button on main page to enter “Menu page”. Press this button in parameter page and move the cursor.

**▲**: During selection, press this button to switch upward or leftward; during modifying data, press this button to increase numerical value. This button supports increment function.

**▼**: During selection, press this button to switch downward or rightward; during modifying data, press this button to decrease numerical value. This button supports decrement function.

**Exit**: Press this button to exit from this option.

**Confirm**: During selection, press this button to confirm the selected option. During modifying data, press this button to confirm parameter value and move cursor.

“Status bar”: It simply indicates the function of the current button.

## 6.3 Debugger Connection

### 6.3.1 Power Supply and Communication Interface

4-core port includes power supply and communication.  
There are two connecting methods:

1) Wiring method 1 of portable debugger:

- Step 1: Remove the display panel and insert its 4-core port into pinboard COM1.
- Step 2: Connect pinboard COM1 to the display panel with the 4-core wiring.
- Step 3: Connect pinboard COM4 to debugger COM1 with the 4-core wiring.

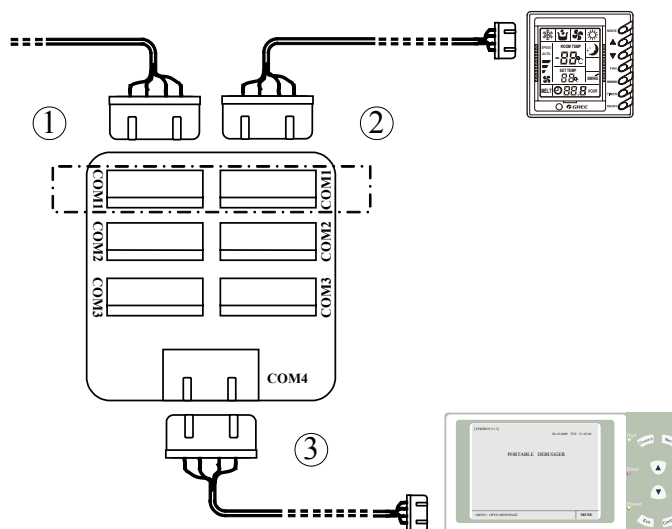

2) Wiring method 2 of portable debugger:

- Step 1: Remove the display panel and insert its 4-core port into debugger COM1.
- Step 2: Connect debugger COM2 to the display panel with the 4-core wiring.

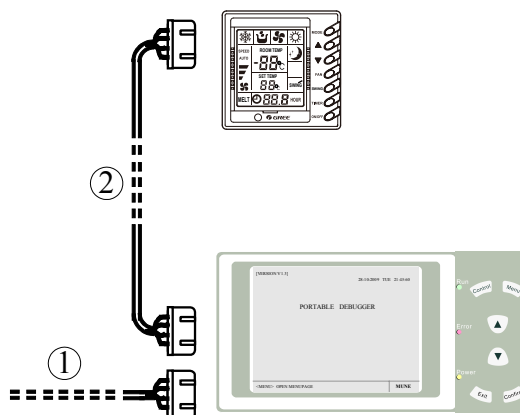

# MAINTENANCE

# MAINTENANCE

## 1 TROUBLE SHOOTING

### 1.1 Trouble Display of Indoor Unit

Error Code	Error	Source of error signal	Control description
E1	Compressor high pressure protection	High pressure switch	The high pressure protection value is 4.2MPa. When high pressure of a compressor is detected for successive three times, the compressor will stop. Error code E1 will be displayed and the running LED will blink.
E2	Indoor antifreezing protection	Temperature sensor of evaporator	When $T_{\text{evaporator}} \leq -2^{\circ}\text{C}$ lasts for 10min, the antifreezing protection will occur. The indoor electronic expansion valve will be closed and the capacity is 0.
E3	Compressor low pressure protection	Low pressure switch	When the low pressure protection value (0.15Mpa, absolute pressure) is reached, the low pressure switch will be disconnected. The low pressure protection will be displayed.
E4	Compressor discharge temperature protection	Discharge temperature sensor	When discharge temperature T is $113^{\circ}\text{C}$ or higher, the stop protection will occur. E4 is displayed upon the first discharge protection. After discharge temperature is lower than $TR^{\circ}\text{C}$ and the unit stops for 3min, the compressor will resume running. If this occurs for three times in one hour, the compressor can not resume running. It is a must to cut off the power and restart the unit.
E5	Conversion overcurrent protection	Compressor driver	The driving board of conversion compressor is wrong. Refer to the error code of outdoor nixie tube for specific error information.
E6	Communication Error	Communication	There is communication error between the mainboard of indoor unit or wired controller and the outdoor unit. The wrong indoor unit will stop and display error code.
E7	Mode conflict	User operation	The running modes of the unit running first and that of later are variant. There is mode conflict among cooling, defrosting and heating mode. There is no mode conflict among fan, cooling, defrosting and heating mode. When mode conflict occurs, the indoor unit will display E7 and stop.
E9	Water full protection	Water pump	When the water is full for successive 8s, the water full protection will occur. The wired controller will display E9 and alarm will occur. In that case, the water pump will work while the other load of indoor unit will stop. The outdoor unit needs to adjust capacity output.
F0	Ambient temperature sensor error of indoor unit	Ambient temperature sensor of indoor unit	The indoor unit of temperature sensor error displays the error code and stop.
F1	Indoor coil pipe inlet temperature sensor error	Indoor coil pipe inlet temperature sensor	The indoor unit of temperature sensor error displays the error code and stop.
F2	Indoor coil pipe middle temperature sensor error	Indoor coil pipe middle temperature sensor	The indoor unit of temperature sensor error displays the error code and stop.
F3	Indoor coil pipe outlet temperature sensor error	Indoor coil pipe outlet temperature sensor	The indoor unit of temperature sensor error displays the error code and stop.
F4	Outdoor ambient temperature sensor error	Outdoor ambient temperature sensor	If short circuit occurs to the temperature sensor, there will be alarm.. The error information will be transmitted to each indoor unit, The error LED or wired controller will display the error code. When outdoor ambient temperature is lower than $-5^{\circ}\text{C}$ , the break circuit of outdoor temperature sensor will be shielded. It is treated according to $-30^{\circ}\text{C}$ .
F7	Outdoor defrosting temperature sensor error	Outdoor defrosting temperature sensor	If short circuit occurs to the temperature sensor, there will be alarm.. The error information will be transmitted to each indoor unit, The error LED or wired controller will display the error code. When outdoor ambient temperature is lower than $-5^{\circ}\text{C}$ , the break circuit of outdoor temperature sensor will be shielded. It is treated according to $-30^{\circ}\text{C}$ .
F9	Discharge temperature sensor error	Discharge temperature sensor	If short circuit occurs to the temperature sensor, there will be alarm.. The error information will be transmitted to each indoor unit, The error LED or wired controller will display the error code. When outdoor ambient temperature is lower than $-5^{\circ}\text{C}$ , the break circuit of outdoor temperature sensor will be shielded. It is treated according to $-30^{\circ}\text{C}$ .

### 1.2 Trouble Display of Mainboard LED of Outdoor Unit

Note: ○ indicates flash, ● indicates dark, ◯ indicates light

Shown on the Patchboard	LEDs on the Outdoor Main Board						Compressor Drive Board			Fan Drive Board			Trouble	Possible Cause	Referenced Solution
	LED1	LED2	LED3	LED4	LED5	LED6	LED1 (Red)	LED2 (Yellow)	LED3 (Green)	LED1 (Red) continuously flashing times	Yellow	Green			
ON	○	●	●	●	○	○	○	●	●	1	●	●	Normal operation	/	/
E5	○	○	○	○	○	○	○	○	○	-	-	-	Overload protection of variable-speed compressor (Drive board detects that the instantaneous current exceeds the limited value set in the software.)	1) Phase loss or reversal happens to the compressor. 2) Abnormal resistance exists in the compressor. 3) The compressor is worn or lack of oil. The system is blocked. 4) Check if the bridge arms of each module are damaged. 5) Drive board of compressor is damaged.	1) Check if there is phase loss or reversal. 2) Measure and check if the resistance is abnormal (When it indicates the compressor is abnormal.) and check if short circuit happens to the grounding resistance. 3) Check if the compressor is worn or lack of oil. And if the system is blocked. 4) When the unit is powered off, use a universal meter to test the positive pressure drop of diode inside the module. If the pressure drop ranges from 0.3V to 0.7V, it means the module is normal; if it shows 0V, it means the module is damaged. 5) Replace the drive board when all the checking items above are normal.
E5	○	○	●	○	○	○	-	-	-	-	-	-	Flood back protection	1) Excessive refrigerant exists in the system. 2) The discharge or top temperature sensor of variable-speed compressor is abnormal.	1) Release some refrigerant. 2) Replace the discharge or top temperature sensor of variable-speed compressor.

Shown on the Patchboard	LEDs on the Outdoor Main Board						Compressor Drive Board			Fan Drive Board			Trouble	Possible Cause	Referenced Solution
	LED1	LED2	LED3	LED4	LED5	LED6	LED1 (Red)	LED2 (Yellow)	LED3 (Green)	LED1 (Red)	LED2 (Yellow)	LED3 (Green)			
E5	○	◎	○	●	◎	○	-	-	-	-	-	-	The discharge temperature of fixed-speed compressor 1 or 2 is low.	1) Excessive refrigerant exists in the system. 2) The discharge temperature sensor of fixed-speed compressor is abnormal. 3) The main board shows the fixed-speed compressor is activated while actually not. 4) The fixed-speed compressor is damaged.	1) Release some refrigerant. 2) Replace the discharge temperature sensor of fixed-speed compressor. 3) Check the signal output on the main board or check the AC contactor. 4) Replace the fixed-speed compressor.
E5	●	●	◎	●	◎	○	-	-	-	-	-	-	Overload protection of fixed-speed compressor 1 or 2	1) The fixed-speed compressor 1 or 2 is overloaded (larger than 9.3A), as a result, the compressor might be damaged. 2) The overcurrent device is invalid with erroneous signal transmitted.	1) Replace the fixed-speed compressor. 2) Replace the overcurrent device.
E5	◎	○	○	○	◎	○	○	◎	○	○	○	○	Radiating fin with high temperature (temperature exceeds the setting value)	1) The bolts on the rectifier or IPM module are not screwed tightly. 2) The radiating paste under the IPM module is dried up. 3) The radiating fin of IPM module is clogged. 4) The compressor drive board is abnormal.	1) Tightly screw up the bolts. 2) Smear some radiating paste. 3) Clear the sundries on the radiating fin. 4) The compressor shows "error" before power on the unit, which indicates the compressor drive board is abnormal. Then replace the drive board.



Shown on the Patchboard	LEDs on the Outdoor Main Board						Compressor Drive Board			Fan Drive Board			Trouble	Possible Cause	Referenced Solution	
	LED1	LED2	LED3	LED4	LED5	LED6	LED1 (Red)	LED2 (Yellow)	LED3 (Green)	LED1 (Red) continuously flashing times	Red	Yellow				Green
E5	○	○	○	○	○	○	○	●	○	-	-	-	-	Abnormal IPM (Protection caused by overload, interference or other abnormal conditions)	<ol style="list-style-type: none"> <li>1) Phase loss or reversal happens to the compressor.</li> <li>2) Abnormal resistance exists in the compressor.</li> <li>3) The compressor is worn or lack of oil. The system is blocked.</li> <li>4) Check if the bridge arms of each module are damaged.</li> <li>5. Drive board of compressor is damaged.</li> </ol>	<ol style="list-style-type: none"> <li>1) Check if there is phase loss or reversal.</li> <li>2) Measure and check if resistance is abnormal (When the resistance exceeds 10Ω, it indicates the compressor is abnormal.) and check if short circuit happens to the grounding resistance.</li> <li>3) Check if the compressor is worn or lack of oil. And if the system is blocked.</li> <li>4) When the unit is powered off, use a universal meter to test the positive pressure drop of diode inside the module. If the pressure drop ranges from 0.3V to 0.7V, it means the module is normal; if it shows 0V, it means the module is damaged.</li> <li>5. Replace the drive board when all the checking items above are normal.</li> </ol>
E5	○	○	○	○	○	○	●	○	-	-	-	-	Sensor on the radiating fin is abnormal (Temperature sensor and its resistance is short-circuit or open-circuit.)	<ol style="list-style-type: none"> <li>1) The compressor drive board is abnormal.</li> </ol>	<ol style="list-style-type: none"> <li>1) Replace the compressor drive board.(Use a universal meter to detect if the temperature sensor is short-circuit or open-circuit.) If the problem can not be solved after electrify the unit for more than three times, then replace the drive board.</li> </ol>	

Shown on the Patchboard	LEDs on the Outdoor Main Board						Compressor Drive Board			Fan Drive Board			Trouble	Possible Cause	Referenced Solution	
	LED1	LED2	LED3	LED4	LED5	LED6	LED1 (Red)	LED2 (Yellow)	LED3 (Green)	LED1 (Red) continuously flashing times	Red	Yellow				Green
E5	○	●	●	●	○	○	●	○	○	-	-	-	Green	Communication error between drive board and main board	<ol style="list-style-type: none"> <li>1) Communication line is loose.</li> <li>2) Communication line is disconnected.</li> <li>3) Communication line is poorly contacted.</li> <li>4) Wired controller is abnormal.</li> </ol>	<ol style="list-style-type: none"> <li>1) Check if the communication line between drive board and main board is loose, if so, fix it well.</li> <li>2) Check if the communication line between drive board and main board is cut off, if so, replace the communication line.</li> <li>3) Check if the communication line between drive board and main board is poorly contacted.</li> <li>4) Try to replace the main board, if trouble disappears, it means the main board is broken. Try to replace the drive board, if trouble disappears, it means the drive board is broken.</li> </ol>
E5	○	○	○	○	○	○	○	●	-	-	-	-	-	High DC input voltage (when the bus voltage exceeds 720VDC)	<ol style="list-style-type: none"> <li>1) High input voltage on the drive board</li> <li>2) Abnormal drive board</li> </ol>	<ol style="list-style-type: none"> <li>1) Check if the input voltage on the drive board is normal. Normal range: 320VAC-460VAC</li> <li>2) If the input voltage is within the normal range, replace the drive board.</li> </ol>
E5	○	○	○	○	○	○	○	○	○	-	-	-	-	Low DC input voltage (when the bus voltage is lowered than 370VDC)	<ol style="list-style-type: none"> <li>1) Low input voltage on the drive board</li> <li>2) The 3-phase power supply is loose.</li> <li>3) Abnormal drive board</li> </ol>	<ol style="list-style-type: none"> <li>1) Check if the input voltage on the drive board is normal. Normal range: 320VAC-460VAC</li> <li>2) Use a universal meter to check if the voltage between live line and neutral line equals to that of each live line (<math>\pm 10V</math>), if not, it means phase loss. Or use an amperemeter to detect the current among every live line, no current indicates phase loss.</li> <li>3) If the input voltage is within the normal range, replace the drive board.</li> </ol>

Shown on the Patchboard	LEDs on the Outdoor Main Board						Compressor Drive Board			Fan Drive Board			Trouble	Possible Cause	Referenced Solution
	LED1	LED2	LED3	LED4	LED5	LED6	LED1 (Red)	LED2 (Yellow)	LED3 (Green)	Red	Yellow	Green			
E5	●	●	○	●	◎	○	◎	○	○	-	-	-	Motor desynchronizing (Before startup of compressor, the rotor position can not be detected or there is a large difference between the actual speed and the setting one.)	IPM module is damaged.	Replace the compressor drive board, if the trouble disappears, it means the drive board is broken; if the trouble exists, it means the system is blocked or the compressor is damaged, which requires system check and compressor replacement.
E5	◎	●	○	●	◎	○	○	●	○	-	-	-	Phase loss and stalling (Error happens when the operating current of compressor is less than the setting value.)	1) Phase loss of the variable-speed compressor 2) Abnormal drive board	1) Check if the winding of compressor is contacted/ connected well with the output terminal of drive board. 2) If it's well-contacted, please replace the drive board.
E5	○	●	◎	○	◎	○	◎	●	○	-	-	-	Ambient temperature sensor error on the drive board (Temperature sensor and its resistance is shortcircuit or open-circuit.)	The drive board of compressor is abnormal.	Use a universal meter to detect if the temperature sensor is short-circuit or open-circuit. If the problem can not be solved after electrify the unit for more than three times, then replace the drive board.

Shown on the Patchboard	LEDs on the Outdoor Main Board						Compressor Drive Board			Fan Drive Board			Trouble	Possible Cause	Referenced Solution
	LED1	LED2	LED3	LED4	LED5	LED6	LED1 (Red)	LED2 (Yellow)	LED3 (Green)	LED1 (Red) continuously flashing times	Yellow	Green			
E5	○	○	○	●	○	○	○	○	●	-	-	-	Startup failure(The compressor can not be started normally.)	1) The compressor is damaged. Slugging and seizing of crankcase happens to the compressor. 2) Phase loss or reversal, or erroneous parameter of compressor 3) Abnormal drive board	1) Check if the compressor is damaged. And if slugging and seizing of crankcase happens to the compressor. 2) Check if the winding of compressor is contacted/ connected well with the output terminal of drive board. 3) Replace the drive board.
E5	○	●	○	○	○	○	-	-	-	-	-	-	Reset of drive module	Abnormal chip or abnormal power supply of chip	If the problem can not be solved after electrify the unit for more than three times, then replace the drive board.
E5	○	○	○	○	○	○	-	-	-	○	●	○	Fan module protection (Protection caused by overload, interference or other abnormal conditions)	1) The fan is damaged. 2) The fan is short-circuit when grounding . 3) Check if the bridge arm of module is short-circuit or damaged. 4) The fan drive board has errors.	1) Use a universal meter to check if the resistance of every fan winding equals to each other, if not, replace the fan. 2) Use a universal meter to check the grounding resistance of fan winding, if it shows 0 Ω or less than 2 Ω, please replace the fan. 3) When the unit is powered off, use a universal meter to test the positive pressure drop of diode inside the module. If the pressure drop ranges from 0.3V to 0.7V, it means the module is normal; if it shows 0V, it means the module is damaged. 4) Replace the fan drive board.

Shown on the Patchboard	LEDs on the Outdoor Main Board						Compressor Drive Board			Fan Drive Board			Trouble	Possible Cause	Referenced Solution
	LED1	LED2	LED3	LED4	LED5	LED6	LED1 (Red)	LED2 (Yellow)	LED3 (Green)	Red	Yellow	Green			
E5	●	○	●	○	□	○	-	-	-	○	○	●	Fan voltage protection (When the voltage on the DC bus deviates from the setting value)	1) The voltage between the live line and neutral line exceeds 290V. 2) The fan drive board is abnormal.	1) Use a universal meter to detect the power supply connected to the unit, if the voltage between live line and neutral line exceeds 290V, please lower the input voltage. 2) If the voltage is normal, please replace the fan drive board.
E5	○	○	●	○	○	○	-	-	-	○	○	○	Fan current protection (Drive board detects that the instantaneous current exceeds the limited value set in the software.)	1) The fan is damaged. 2) The fan is short-circuit when grounding. 3) Check if the bridge arm of module is short-circuit or damaged. 4) The fan drive board has errors.	1) Use a universal meter to check if the resistance of every fan winding equals to each other, if not, replace the fan. 2) Use a universal meter to check the grounding resistance of fan winding, if it shows 0 Ω or less than 2 Ω, please replace the fan. 3) When the unit is powered off, use a universal meter to test the positive pressure drop of diode inside the module. If the pressure drop ranges from 0.3V to 0.7V, it means the module is normal; if it shows 0V, it means the module is damaged. 4) Replace the fan drive board.
E5	○	●	●	○	○	○	-	-	-	○	○	○	Fan module overheat protection (Protection happens when the temperature of radiating fin exceeds the setting value)	1) The two bolts on the IPM module are not screwed tightly. 2) The radiating paste under the IPM module is dried up. 3) The radiating fin of IPM module is clogged. 4) The compressor drive board is abnormal.	1) Tightly screw up the bolts. 2) Smear some radiating paste. 3) Clear the sundries on the radiating fin. 4. The fan shows "error" before power on the unit, which indicates the fan drive board is abnormal.

Shown on the Patchboard	LEDs on the Outdoor Main Board						Compressor Drive Board			Fan Drive Board			Trouble	Possible Cause	Referenced Solution	
	LED1	LED2	LED3	LED4	LED5	LED6	LED1 (Red)	LED2 (Yellow)	LED3 (Green)	LED1 (Red) continuously flashing times	Red	Yellow				Green
E5	●	●	●	○	○	○	-	-	-	-	○	○	-	1) Overload protection line of the fan is not connected with the terminal X7 and X8 located on the drive board. (Applicable to dual-fan unit) 2) Use a universal meter to detect the overload protection line. If it is short-circuit, it means the motor is normal; if it is open-circuit, it means the fan is damaged and replace the fan. (Applicable to dual-fan unit) 3) Replace the fan drive board.	1) Connect the overload protection line with the terminal X7 and X8 located on the drive board. (Applicable to dual-fan unit) 2) Use a universal meter to detect the overload protection line. If it is short-circuit, it means the motor is normal; if it is open-circuit, it means the fan is damaged and replace the fan. (Applicable to dual-fan unit) 3) Replace the fan drive board.	1) If the communication line between the drive board and main board is loose, please fix it well. 2) If the communication line between the drive board and main board is disconnected, replace the communication line. 3) Check if the communication line between main board and fan drive board is connected well. 4) For dual-fan unit, the DIP switch of those two fan drive boards should be set the same. 5) Try to replace the main board, if trouble disappears, it means the main board is broken. Try to replace the drive board, if trouble disappears, it means the drive board is broken.
E5	○	○	○	●	○	○	-	-	-	5	●	○	○	1) Communication line is loose. 2) Communication line is disconnected. 3) Communication line is poorly contacted. 4) The DIP switch of fan drive board is wrongly set. (For dual-fan unit) 5) Wired controller is abnormal.	1) Communication line is loose. 2) Communication line is disconnected. 3) Communication line is poorly contacted. 4) The DIP switch of fan drive board is wrongly set. (For dual-fan unit) 5) Wired controller is abnormal.	1) Communication line is loose. 2) If the communication line between the drive board and main board is disconnected, replace the communication line. 3) Check if the communication line between main board and fan drive board is connected well. 4) For dual-fan unit, the DIP switch of those two fan drive boards should be set the same. 5) Try to replace the main board, if trouble disappears, it means the main board is broken. Try to replace the drive board, if trouble disappears, it means the drive board is broken.
E5	○	○	○	○	○	○	○	○	○	-	-	-	-	The compressor drive board is abnormal.	Replace the compressor drive board.	Replace the compressor drive board.

Shown on the Patchboard	LEDs on the Outdoor Main Board						Compressor Drive Board			Fan Drive Board			Trouble	Possible Cause	Referenced Solution
	LED1	LED2	LED3	LED4	LED5	LED6	LED1 (Red)	LED2 (Yellow)	LED3 (Green)	LED1 (Red)	LED2 (Yellow)	LED3 (Green)			
-	○	●	○	●	○	○	-	-	-	-	-	-	Communication error between slave module and main board; abnormal communication between modules. Check the communication line, etc.	1) Master module or slave module is abnormal. (check if the unit is electrified.) 2) The address code of main board doesn't match with the quantity code. 3) Communication line is poorly contacted with the main board. 4) Communication line is damaged. The capacity code of SW1 is wrongly set.	1) Check if the master module and slave modules are normally electrified. 2) Check if the address code and the quantity code is set correctly. 3) Check if the communication line is connected well with the main board. 4) Check if the communication line is completely alright, replace the communication line if necessary.
-	○	●	○	●	○	○	-	-	-	-	-	-	Capacity code is wrong	The capacity code of SW1 is wrongly set.	Check if the SW1 is wrongly set.
E3	●	○	○	○	○	○	-	-	-	-	-	-	Refrigerant deficiency protection (When refrigerant deficiency happens, the unit can not be started normally due to low pressure in the system.)	1) The refrigerant almost completely leaks out. 2) The refrigerant is fake.	1) Check where the leakage point locates and recharge the refrigerant. 2) Release the refrigerant. Recharge the real R410A refrigerant.
E3	●	○	○	○	○	○	-	-	-	-	-	-	Compressor low pressure protection (The unit requires protection when the low pressure reaches the setting value.)	1) Refrigerant deficiency 2) The system is blocked. 3) The electronic expansion valve can not be operated or it is clogged. 4) The low pressure sensor is abnormal.	1) Use a manometer to detect the system pressure and supplement some refrigerant. 2) Check the location where the system is blocked. 3) Check the electronic expansion valve and its coil. 4) Replace the low pressure sensor and check the interface of main board.

Shown on the Patchboard	LEDs on the Outdoor Main Board						Compressor Drive Board			Fan Drive Board			Trouble	Possible Cause	Referenced Solution
	LED1	LED2	LED3	LED4	LED5	LED6	LED1 (Red)	LED2 (Yellow)	LED3 (Green)	LED1 (Red)	LED2 (Yellow)	LED3 (Green)			
E4	○	○	●	●	○	○	-	-	-	-	-	-	Compressor discharge protection (The unit requires stop protection when the discharge temperature reaches the setting value.)	1) Refrigerant deficiency 2) The discharge temperature sensor is abnormal.	1) Supplement some refrigerant. 2) Check the discharge temperature sensor or exchange it with other compressor temperature sensor, replace the sensor if it is broken. (Use the computer or debugger to check which compressor discharge temperature is high.)
E1	○	●	●	●	○	○	-	-	-	-	-	-	Compressor high pressure protection(The unit requires stop protection when the high pressure reaches the setting value.)	1) Excessive refrigerant exists in the system, which leads to high pressure in the system. 2) The system is blocked. 3) The electronic expansion valve can not be operated or it is clogged. 4) The high pressure sensor is abnormal. 5) The high pressure switch is abnormal.	1) Release some refrigerant. 2) Check the location where the system is blocked. 3) Check the electronic expansion valve and its coil. 4) Replace the high pressure sensor and check the interface of main board. 5) When the unit is powered off, use a universal meter to detect the voltage values of high pressure switch, if it doesn't show 12V, it means the pressure switch is disconnected.
E6	●	○	○	●	○	○	-	-	-	-	-	-	Communication error between indoor and outdoor units	Communication line between indoor and outdoor units is abnormal.	Check if the communication line is disconnected or damaged.
F4	●	●	○	○	○	○	-	-	-	-	-	-	Ambient temperature sensor error	Abnormal temperature sensor	Check if the temperature sensor is damaged.



Shown on the Patchboard	LEDs on the Outdoor Main Board						Compressor Drive Board			Fan Drive Board			Trouble	Possible Cause	Referenced Solution
	LED1	LED2	LED3	LED4	LED5	LED6	LED1 (Red)	LED2 (Yellow)	LED3 (Green)	Red	Yellow	Green			
F5	○	●	●	○	○	○	-	-	-	-	-	-	Coil inlet temperature sensor error	Abnormal temperature sensor	Check if the temperature sensor is damaged.
F6	●	○	●	○	○	○	-	-	-	-	-	-	Coil midway temperature sensor error	Abnormal temperature sensor	Check if the temperature sensor is damaged.
F7	○	○	●	○	○	○	-	-	-	-	-	-	Coil outlet temperature sensor error	Abnormal temperature sensor	Check if the temperature sensor is damaged.
F8	●	●	○	○	○	○	-	-	-	-	-	-	Discharge temperature sensor error of fixed-speed compressor 1	Abnormal temperature sensor	Check if the temperature sensor is damaged.
F8	○	●	○	○	○	○	-	-	-	-	-	-	Discharge temperature sensor error of fixed-speed compressor 2	Abnormal temperature sensor	Check if the temperature sensor is damaged.
F9	○	●	○	○	○	○	-	-	-	-	-	-	Discharge temperature sensor error of variable-speed compressor	Abnormal temperature sensor	Check if the temperature sensor is damaged.
F9	○	●	●	○	○	○	○	○	○	-	-	-	Top Temperature sensor error of variable-speed compressor	Abnormal temperature sensor	Check if the temperature sensor is damaged.

Shown on the Patchboard	LEDs on the Outdoor Main Board						Compressor Drive Board			Fan Drive Board			Trouble	Possible Cause	Referenced Solution
	LED1	LED2	LED3	LED4	LED5	LED6	LED1 (Red)	LED2 (Yellow)	LED3 (Green)	LED1 (Red)	LED2 (Yellow)	LED3 (Green)			
FC	○	○	○	○	○	○	-	-	-	-	-	-	High pressure sensor error	Abnormal sensor	Check if the sensor is damaged.
Fd	○	○	○	○	○	○	-	-	-	-	-	-	Low pressure sensor error	Abnormal sensor	Check if the sensor is damaged.
-	○	○	●	○	○	○	○	○	○	-	-	-	Top temperature sensor error of fixed-speed compressor 1	Abnormal temperature sensor	Check if the temperature sensor is damaged.
-	●	○	●	○	○	○	○	○	○	-	-	-	Top temperature sensor error of fixed-speed compressor 2	Abnormal temperature sensor	Check if the temperature sensor is damaged.
-	○	○	○	●	○	○	-	-	-	-	-	-	The number of module doesn't accord with that of the DIP switch.	The number of module doesn't accord with that of the DIP switch SW2.	Check if the DIP switch is set right.
-	●	○	○	○	○	○	-	-	-	-	-	-	Errors of other modules	Other modules have "error" displayed.	
-	○	○	○	○	○	○	-	-	-	-	-	-	Defrosting	Normal	
-	○	○	○	○	○	○	-	-	-	-	-	-	Oil Returning	Normal	
-	○	○	○	○	○	○	-	-	-	-	-	-	Oil Balancing	Normal	

## 2 FLOW CHART OF TROUBLESHOOTING

The repair personnel shall collect the error information as more as possible for careful study and list those electric or system parts that might cause the error. Then, the repair personnel shall be able to identify the specific cause of error and find out the problem parts.

Keep an eye on the complete equipment. Do not restrict to a part, but taking care to check the state of complete equipment.

Study from the simple point. To analyze, judge and identify the cause of trouble, please start from the simple operation and finally proceed to such complicated operations as discharge of refrigerant, disassembly of equipment, replacement of parts and filling of refrigerant. Be prudent to find out the cause. The unit might be incurred to multiple errors, and such errors might be caused by multiple reasons. It is also possible that one error is developed into multiple errors. Therefore, a comprehensive analysis system shall be set up to ensure that the result of judgment is more correct and reliable

### 2.1 High-pressure Protection

Error display on hand controller: E1

Outdoor units mainboard indicator: led4: dark; led3: dark; led2: dark; led1: blink

Indoor units mainboard indicators:

Patio indoor units: red led: blink; green led: dark; yellow led: dark

FY wall-mounting motor: red led: blink; yellow led: dark

New FY wall-mounting motor: red led: blink; green led: dark; yellow led: dark

Hanging indoor units: red led: blink; green led: dark; yellow led: dark

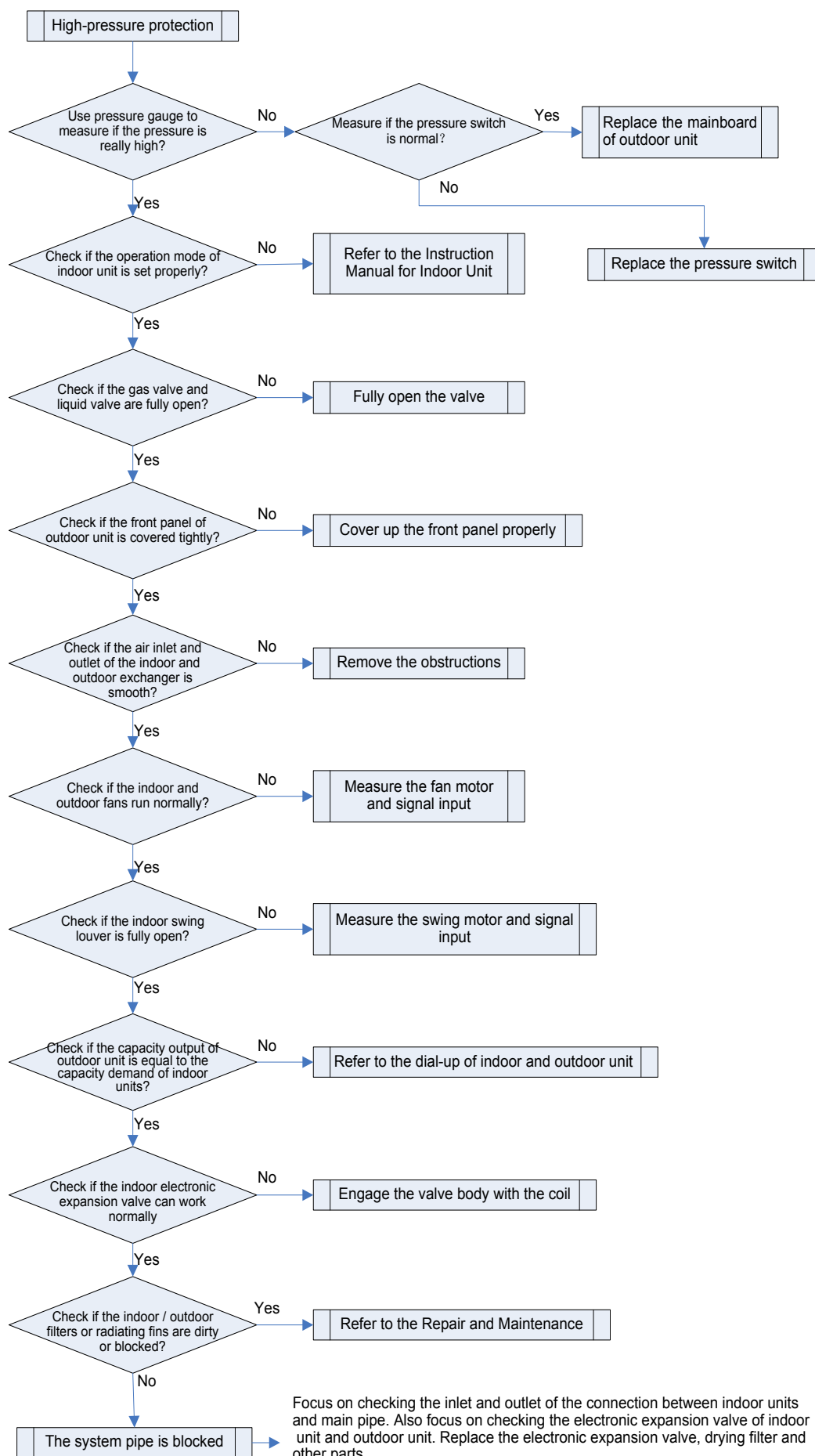

Focus on checking the inlet and outlet of the connection between indoor units and main pipe. Also focus on checking the electronic expansion valve of indoor unit and outdoor unit. Replace the electronic expansion valve, drying filter and other parts

## 2.2 Low-pressure Protection

Error display on hand controller: E3

Outdoor units mainboard indicator: led4: dark; led3: dark; led2: blink; led1: dark (low voltage)  
led4: blink; led3: blink; led2: bright; led1: dark (lack of refrigerant)

Indoor units mainboard indicators:

Patio indoor units: red led: blink; red led: blink; green led: dark; yellow led: dark

FY wall-mounting motor: red led: blink; yellow led: dark

New FY wall-mounting motor: red led: blink; green led: dark; yellow led: dark

Hanging indoor units: red led: blink; green led: dark; yellow led: dark

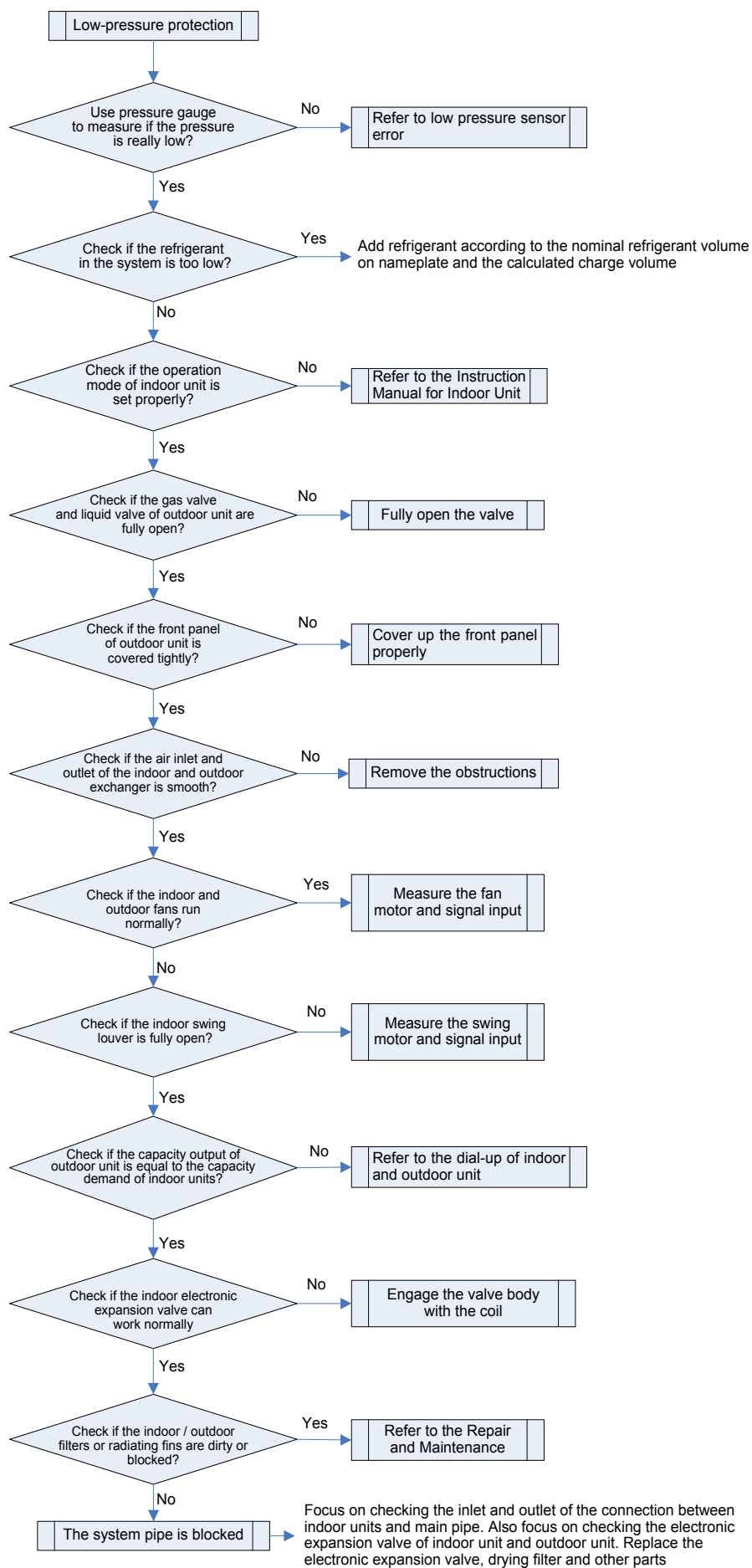

### 2.3 Exhaust Temperature Protection

Error display on hand controller: E4

Outdoor units mainboard indicator: led4: dark; led3: dark; led2: blink; led1: blink

Indoor units mainboard indicators:

Patio indoor units: red led: blink; red led: blink; green led: dark; yellow led: dark

FY wall-mounting motor: red led: blink; yellow led: dark

New FY wall-mounting motor: red led: blink; green led: dark; yellow led: dark

Hanging indoor units: red led: blink; green led: dark; yellow led: dark

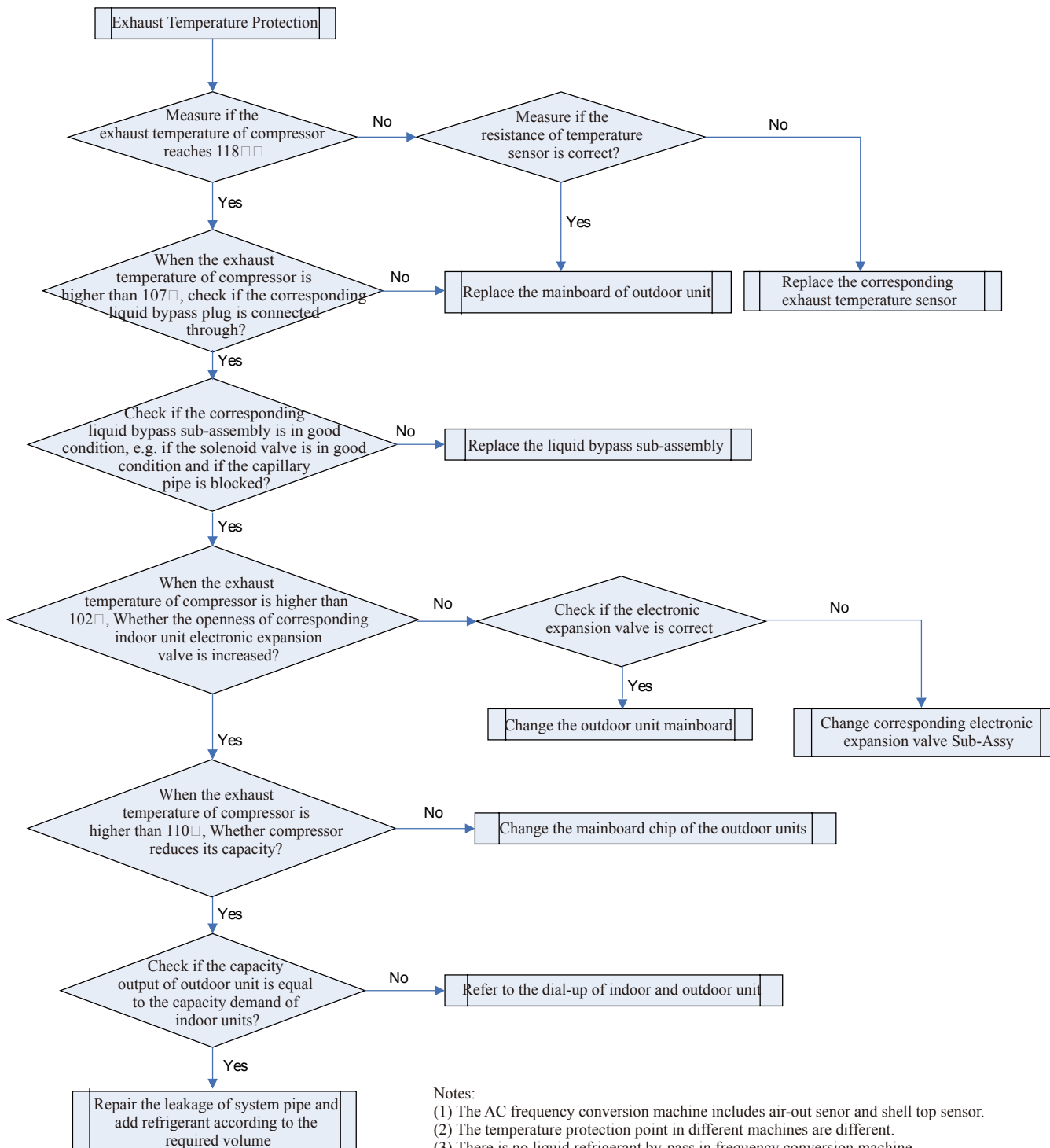

## 2.4 Communication Failure

Error display on hand controller: E6

Outdoor units mainboard indicator: led4: dark; led3: blink; led2: blink; led1:dark

Indoor units mainboard indicators:

Patio indoor units: red led: blink:red led:blink; green led:blink; yellow led:blink

FY wall-mounting motor: red led:blink(dark at the same time); yellow led:blink

New FY wall-mounting motor: red led:blink; green led:blink; yellow led:blink

Hanging indoor units: red led:blink; green led:blink; yellow led:blink

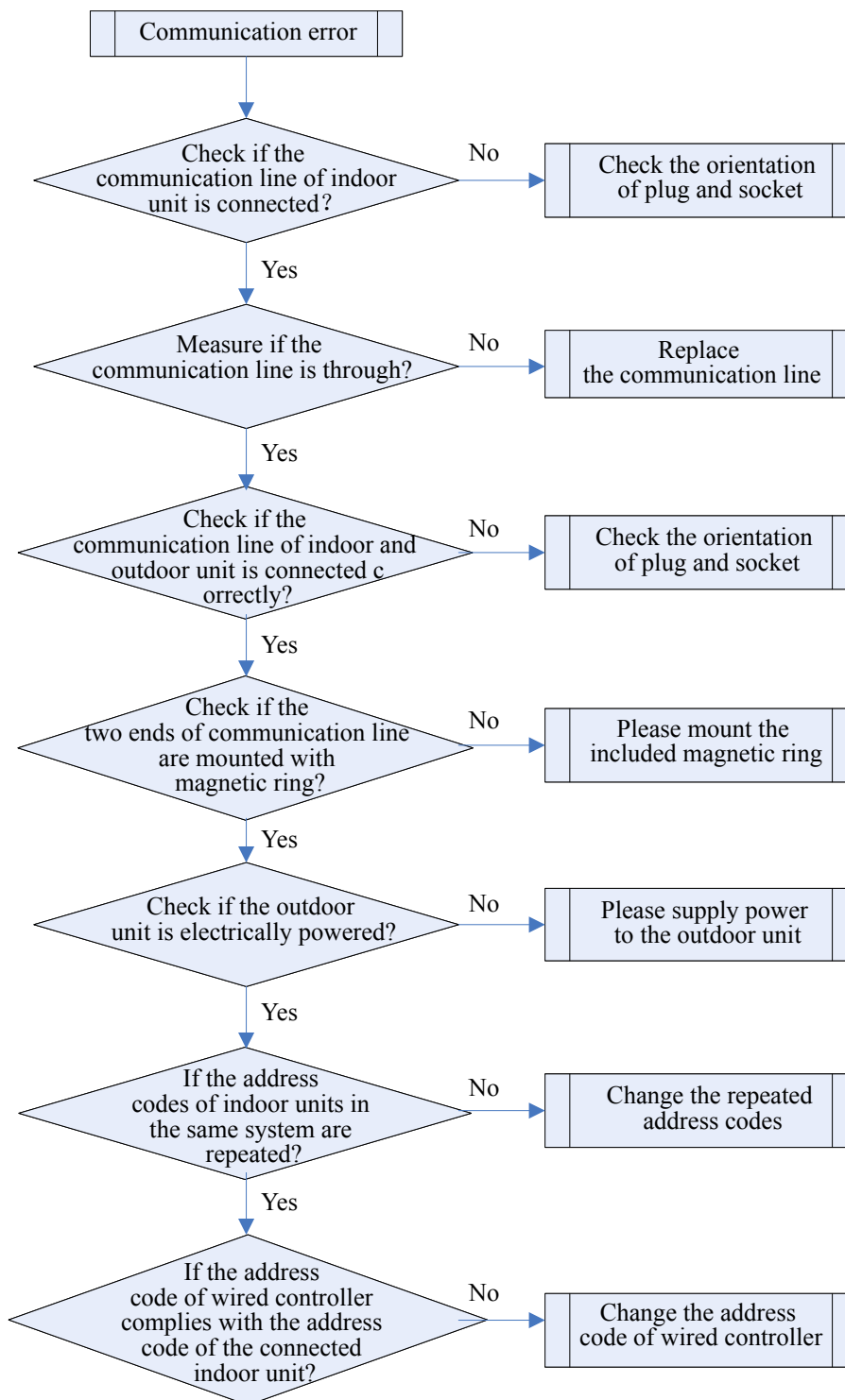



## 2.5 Temperature sensor Trouble

- 1) Outdoor ambient temperature sensor error
  - Error display on hand controller: F4
  - Outdoor units mainboard indicator: led4: dark; led3: dark; led2: dark; led1: dark
  - Indoor units mainboard indicators:
    - Patio indoor units: red led: blink:red led:blink; green led:dark; yellow led:dark
    - FY wall-mounting motor: red led:blink; yellow led:dark
    - New FY wall-mounting motor: red led:blink; green led:dark; yellow led:dark
    - Hanging indoor units: red led:blink; green led:dark; yellow led:dark
- 2) Outdoor coil pipe inlet sensor trouble
  - Error display on hand controller: F5
  - Outdoor units mainboard indicator: led4: blink; led3: dark; led2: dark; led1: blink
- 3) Outdoor coil pipe middle sensor trouble
  - Error display on hand controller: F6
  - Outdoor units mainboard indicator: led4: blink; led3: dark; led2: blink; led1: dark
- 4) Outdoor coil pipe outlet sensor trouble
  - Error display on hand controller: F7
  - Outdoor units mainboard indicator: led4: blink; led3: dark; led2: blink; led1: blink
  - Indoor units mainboard indicators:
    - Patio indoor units: red led: blink: red led:blink; green led:dark; yellow led:dark
    - FY wall-mounting motor: red led:blink; yellow led:dark
    - New FY wall-mounting motor: red led:blink; green led:dark; yellow led:dark
    - Hanging indoor units: red led:blink; green led:dark; yellow led:dark
- 5) Fixed-frequency exhaust temperature sensor error
  - Error display on hand controller: F8
  - Outdoor units mainboard indicator: led4: blink; led3: blink; led2: dark; led1: dark (fixed frequency 1)  
led4: blink; led3: blink; led2: dark; led1: bright (fixed frequency2)
- 6) Variable-frequency exhaust temperature sensor error
  - Error display on hand controller: F9
  - Outdoor units mainboard indicator: led4:blink; led3: blink; led2: dark; led1: blink (air-out sensor)  
led4:bright; led3: dark; led2: dark; led1:blink (sensor of housing head cover)

7) Indoor units mainboard indicators:

Patio indoor units: red led: blink:red led:blink; green led:dark; yellow led:dark

FY wall-mounting motor: red led:blink; yellow led:dark

New FY wall-mounting motor: red led:blink; green led:dark; yellow led:dark

Hanging indoor units: red led:blink; green led:dark; yellow led:dark

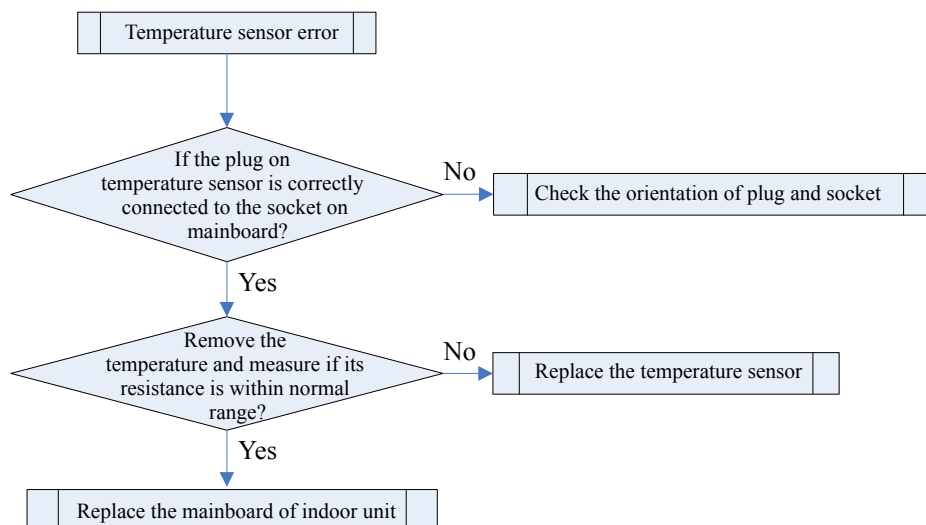

2.6 Sensor Trouble

1) High-voltage sensor error

Error display on hand controller: Fc

Outdoor units mainboard indicator: led4: bright; led3: blink; led2: blink; led1: blink

Indoor units mainboard indicators:

Patio indoor units: red led: blink:red led:blink; green led:dark; yellow led:dark

FY wall-mounting motor: red led:blink; yellow led:dark

New FY wall-mounting motor: red led:blink; green led:dark; yellow led:dark

Hanging indoor units: red led:blink; green led:dark; yellow led:dark

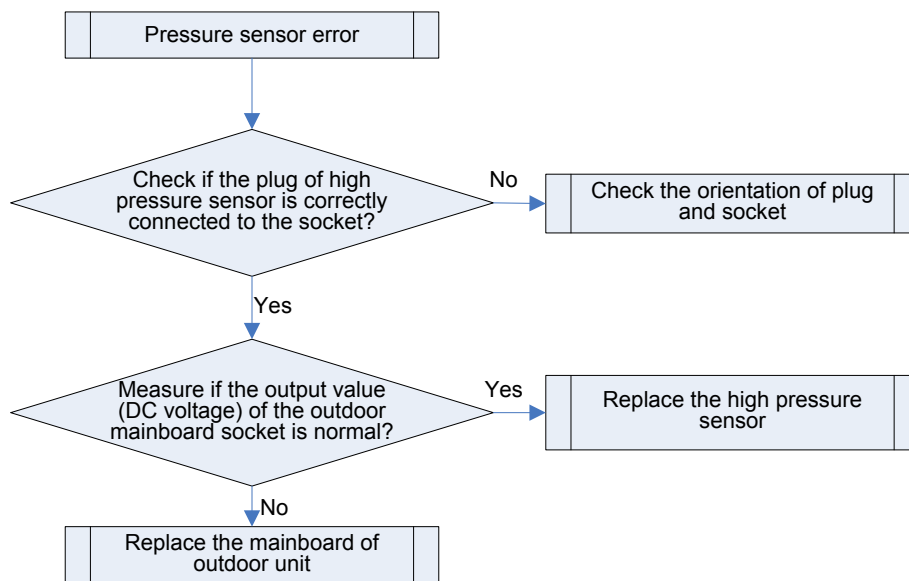

Troubleshooting steps for low-voltage sensor and high-voltage sensor

2) Low-voltage sensor error

Error display on hand controller: Fd

Outdoor units mainboard indicator: led4: bright; led3: bright; led2: blink; led1: blink

Indoor units mainboard indicators:

Patio indoor units: red led: blink; red led: blink; green led: dark; yellow led: dark

FY wall-mounting motor: red led: blink; yellow led: dark

New FY wall-mounting motor: red led: blink; green led: dark; yellow led: dark

Hanging indoor units: red led: blink; green led: dark; yellow led: dark

## 2.7 No energization to the unit and mainboard

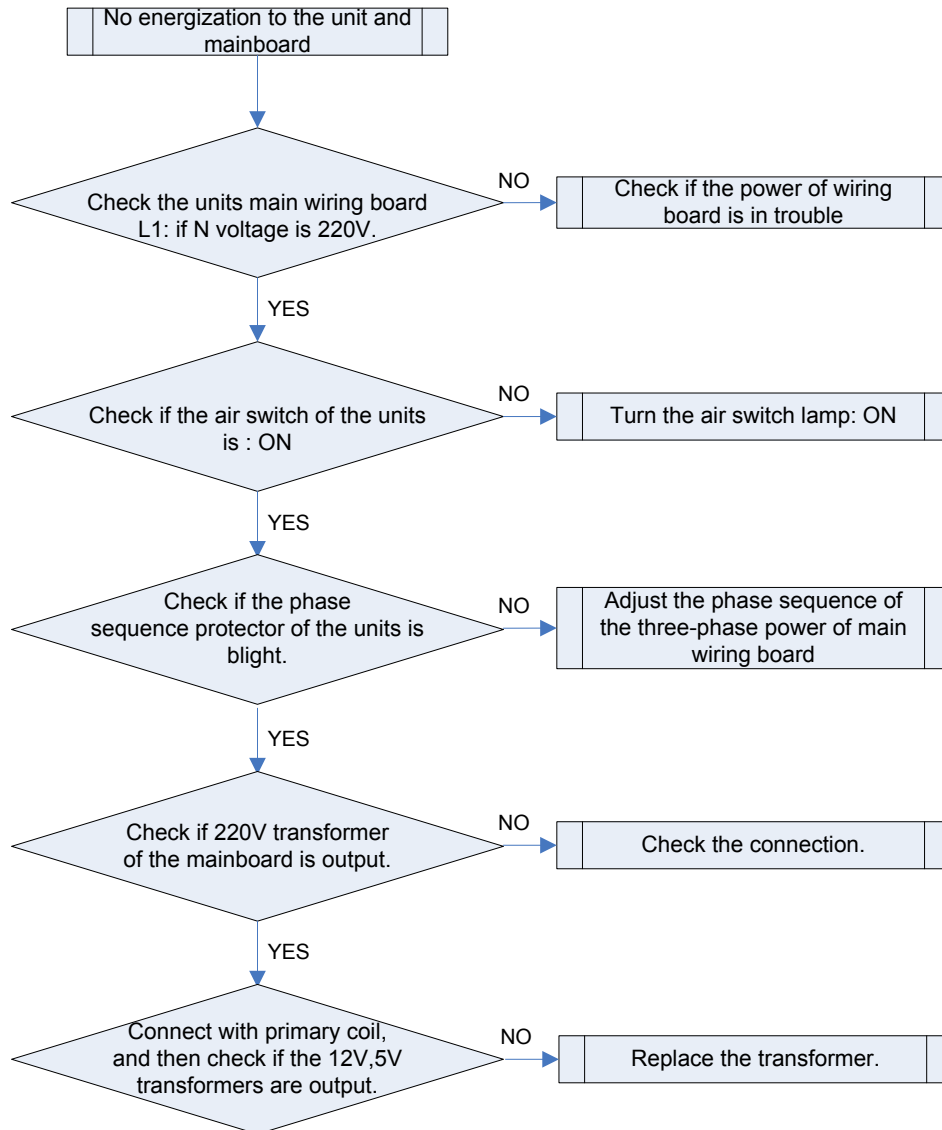

## 2.8 The AC contactor does not pull in

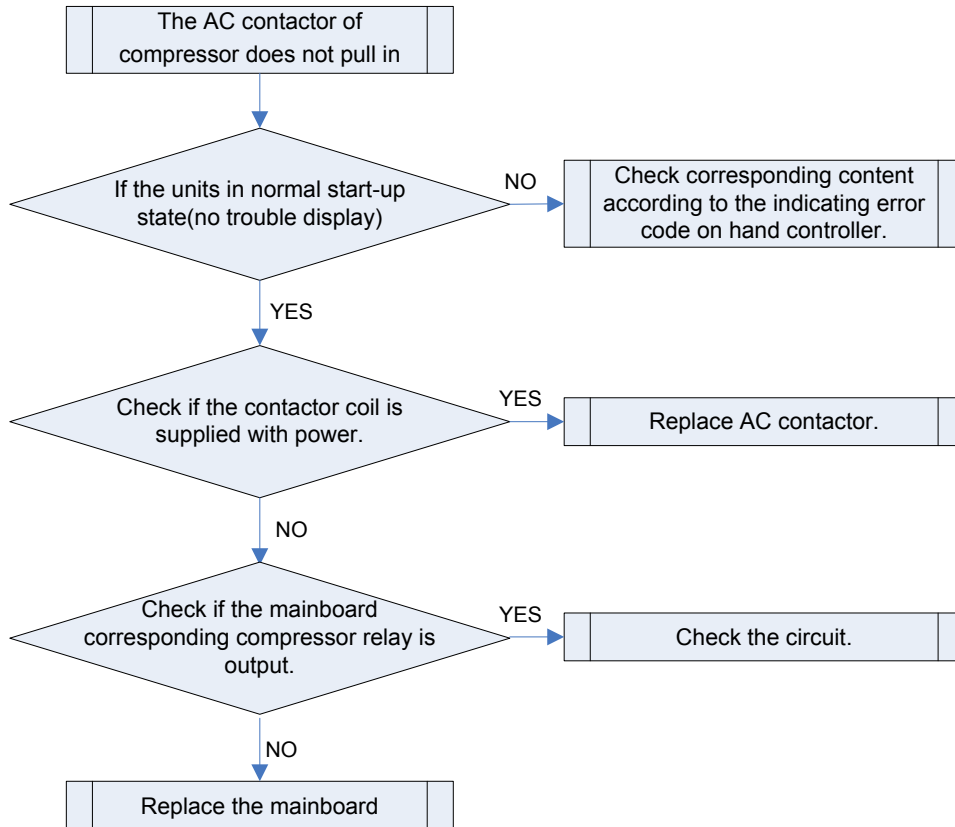

## 2.9 Typical troubleshooting (E5) for DC frequency conversion drive board

When the error E5 arises, please firstly check the LED status of the main control board, drive board of the fan motor, and also drive board of the compressor, after that, confirm what the error is through the error list, finally check out and eliminate the error.

### 1) Solution to the Communication Error between the Compressor Drive Board and the Main Control Board

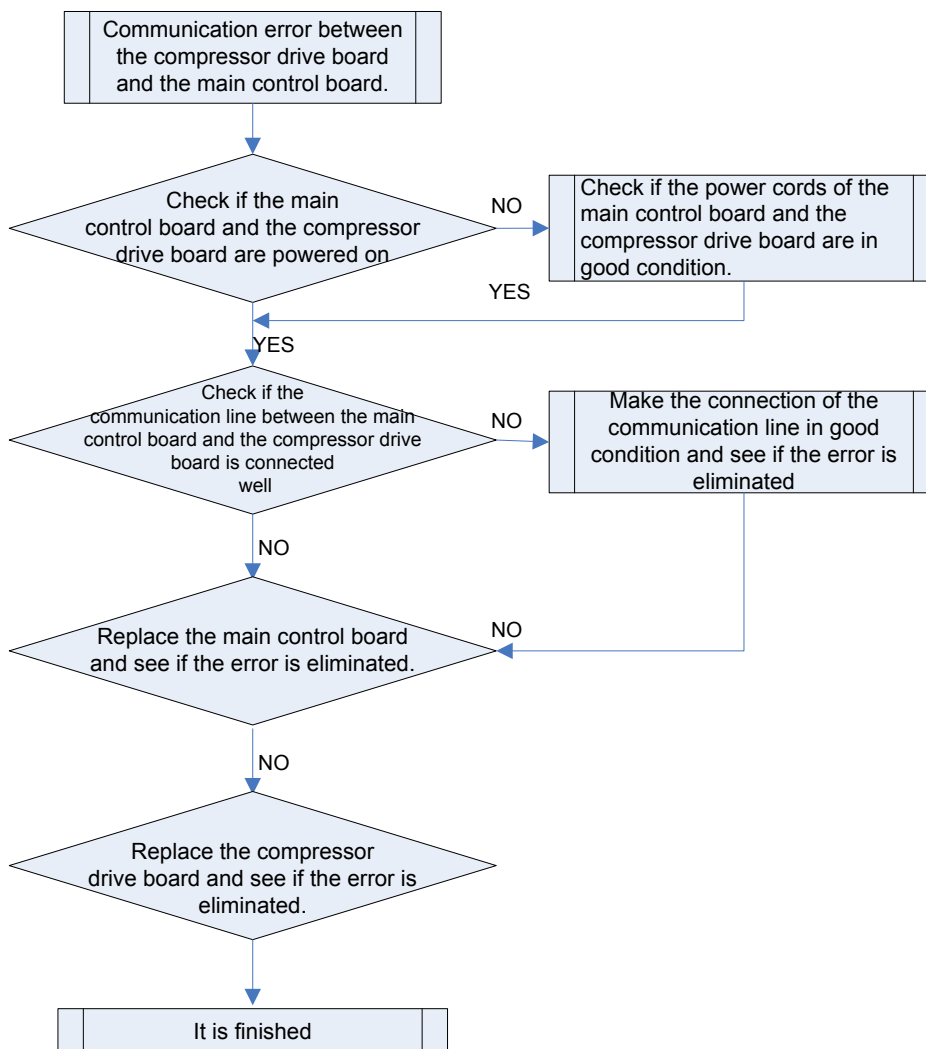

## 2) Solution to the Compressor Drive Board and IPM Module Protection Error

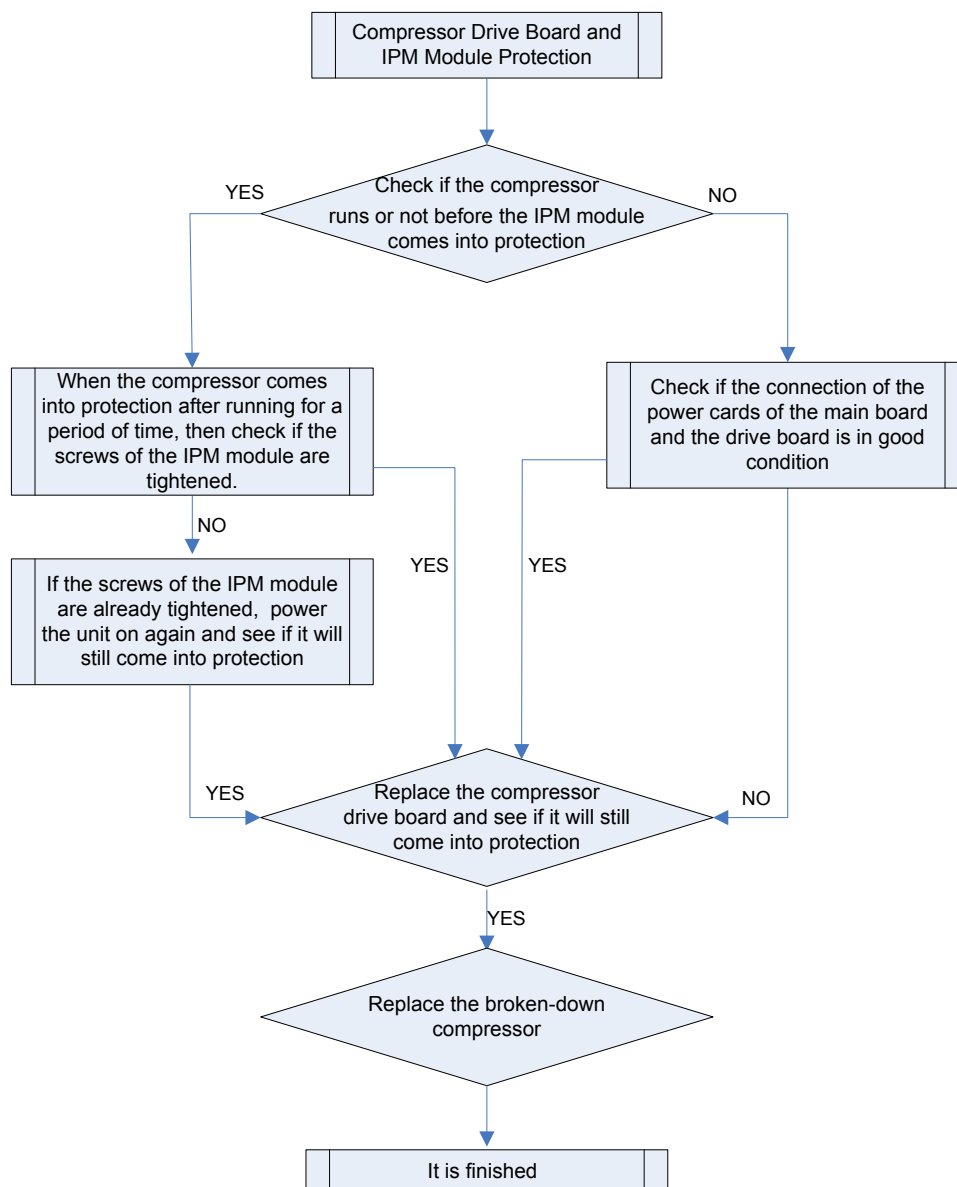

Method to test if the IPM Module IS Shortcut:

1) Preparation before check: prepare a universal meter which is turned to the diode option, and then remove the wires U, V, W from the drive board of the compressor which has been powered off for one minute.

2) The test comes into two steps

Step 1: put the black probe of the universal meter on the place P and the red on the wiring terminal U, V, W respectively to measure the voltage between UP, VP, WP.

Step 2: put the red probe of the universal meter on the place N and the black on the wiring terminal U, V, W respectively to measure the voltage between NU, NV, NW.

3) If the measured values between UP, VP, WP, NU, NV, NW

are all among 0.3V~0.7V, it indicates the IPM is normal; if there is any value which is 0V, it indicates that the IPM module is damaged.

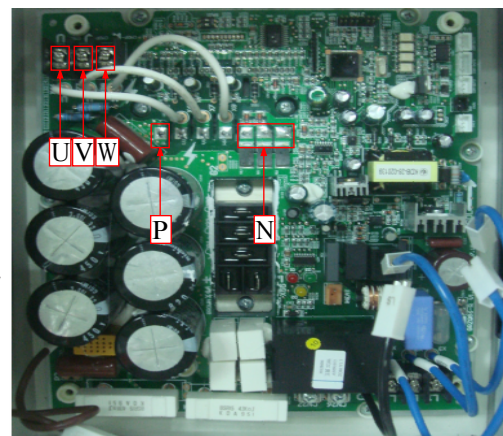

### 3) Solution to the DC Bus High Voltage Protection

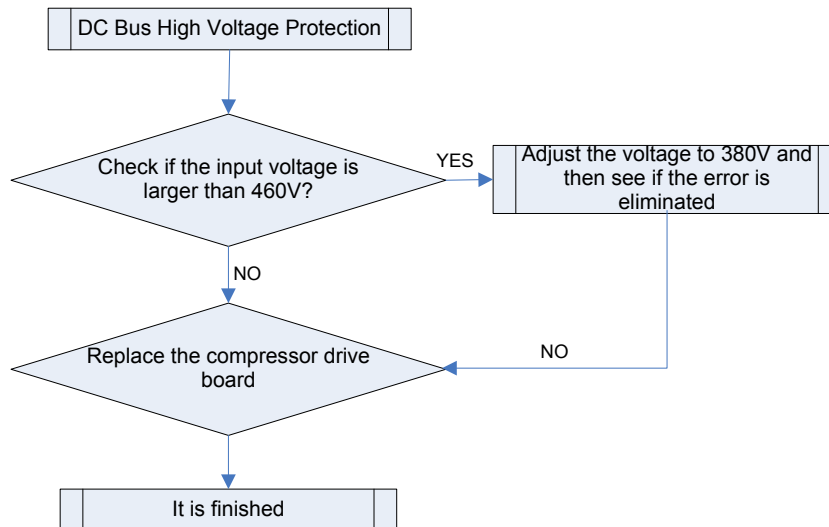

### 4) Solution to DC Bus Low Voltage Protection

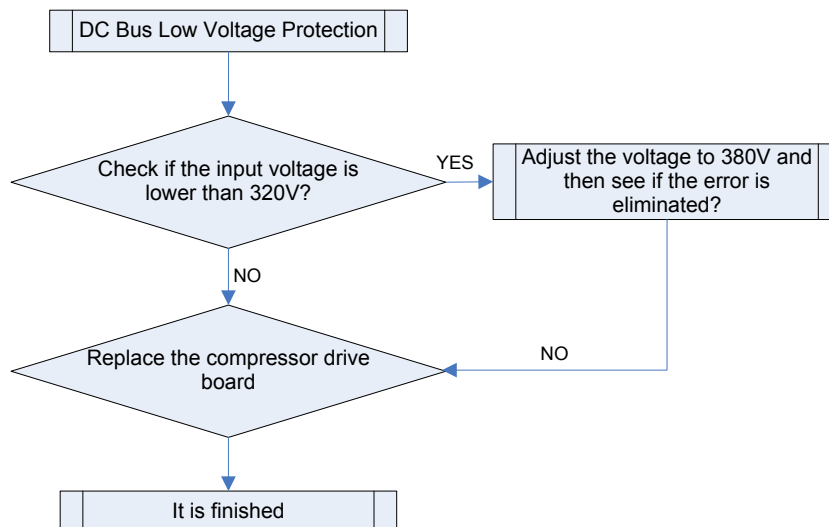

Note: For both the compressor and fan motor drive boards, the solution to DC bus low/high voltage protection is the same.

### 5) Solution to the Open Phase Protection

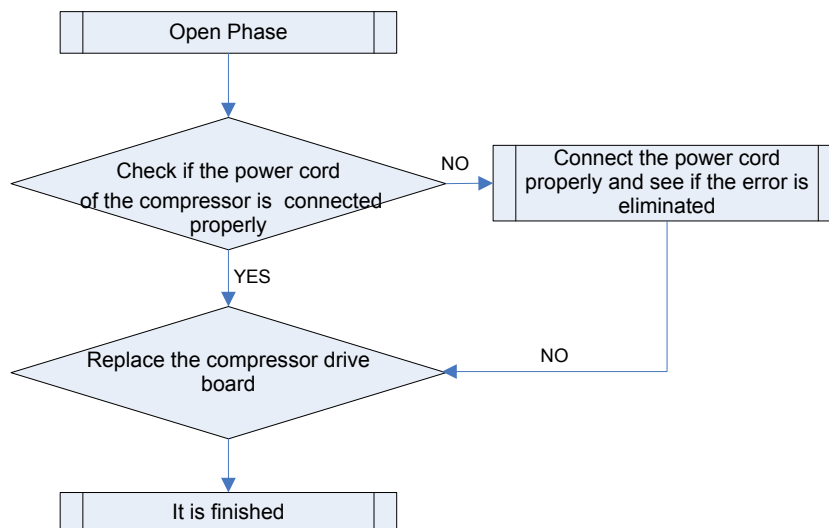

6) Solution to the Current Transducer Error

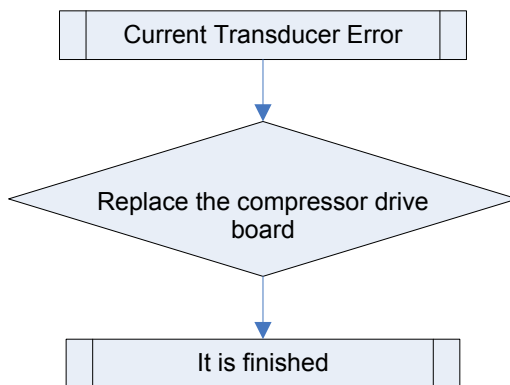

7) Solution to IPM High Temperature Protection

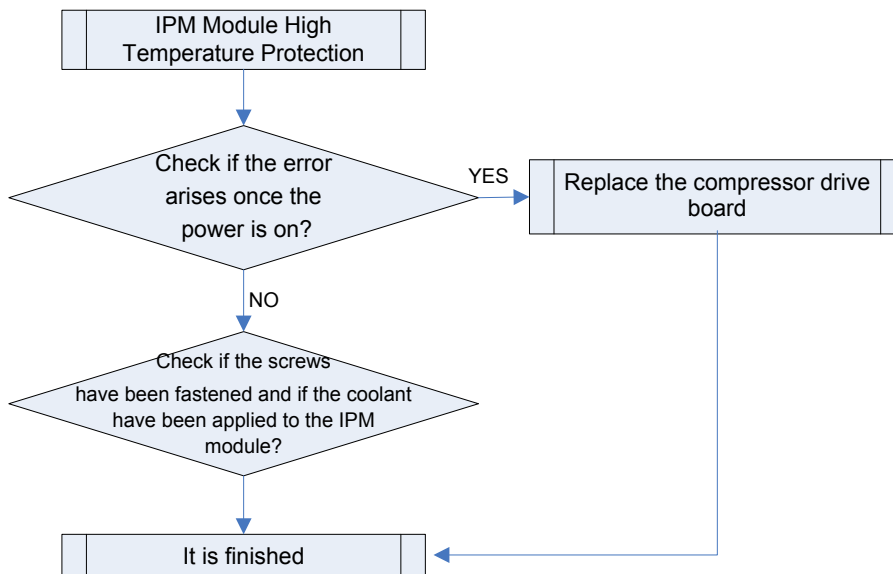

8) Solution to Fan Motor High Drive Current Protection

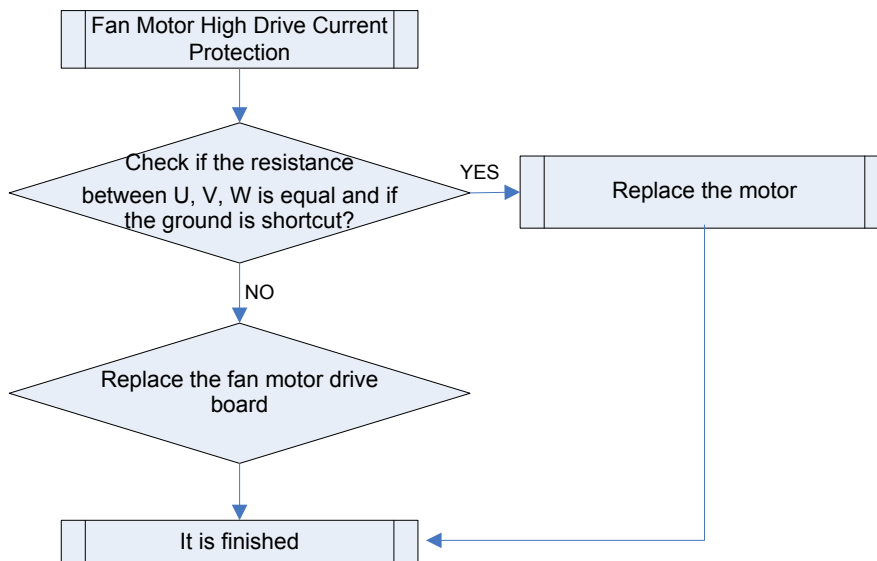



9) Solution to the Communication Error of the Fan Motor Drive Board

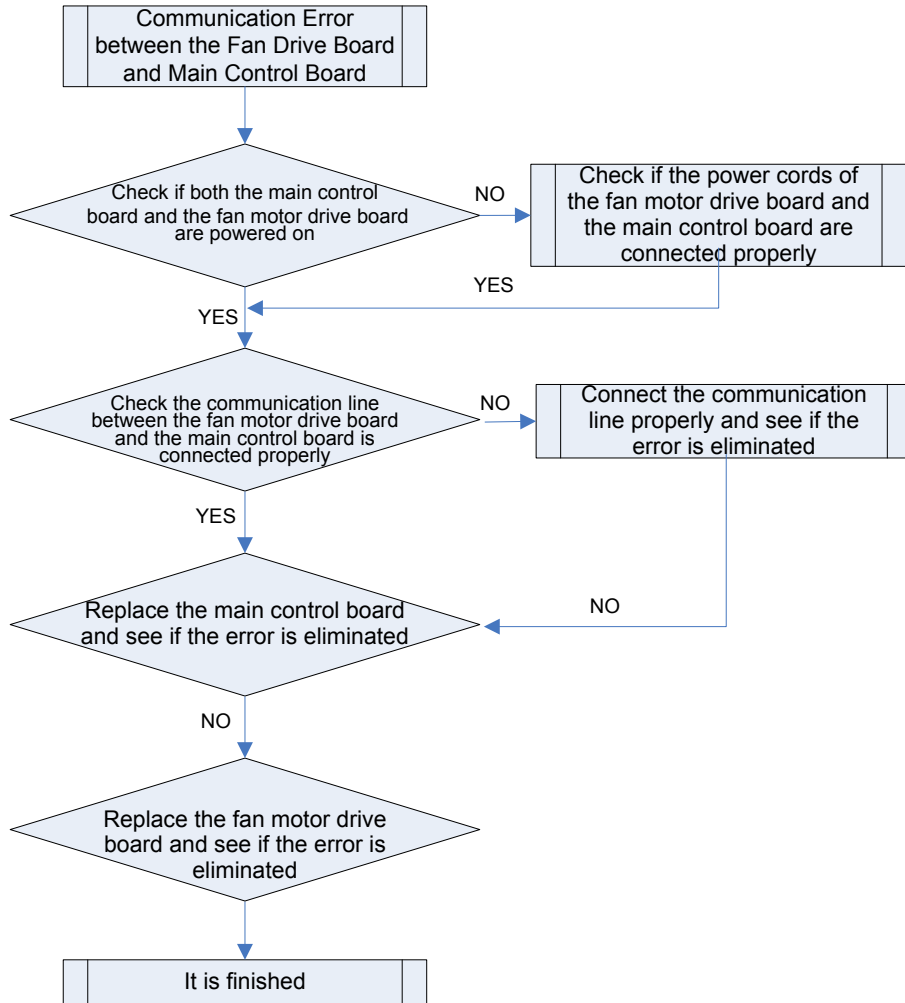

10) Solution to the Fan Motor Overheating Protection

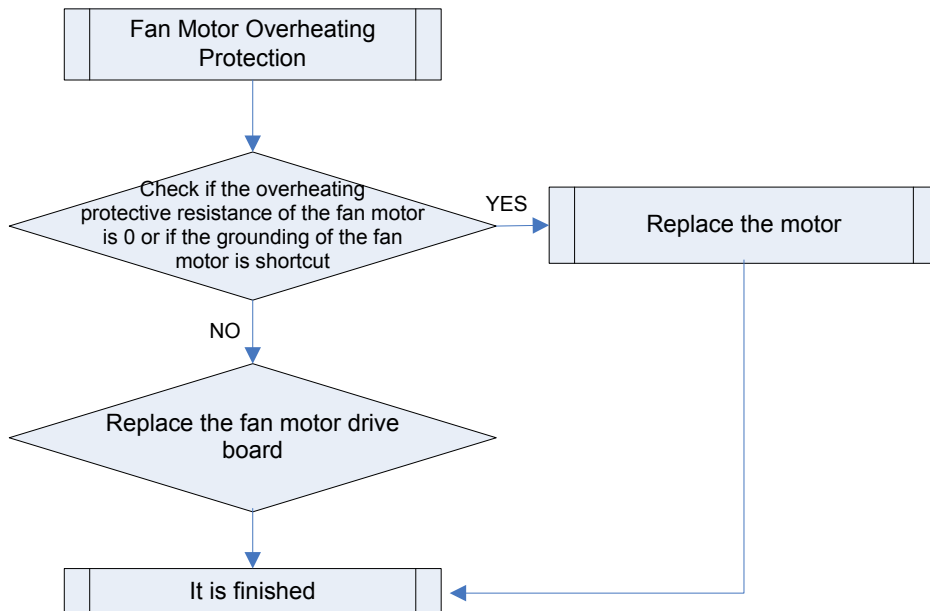

## 2.10 E5 Protection

Error display on hand controller: E5

Outdoor units mainboard indicator: /

Indoor units mainboard indicators:

Patio indoor units: red led: blink; red led:blink; green led:dark; yellow led:dark

FY wall-mounting motor: red led:blink; yellow led:dark

New FY wall-mounting motor: red led:blink; green led:dark; yellow led:dark

Hanging indoor units: red led:blink; green led:dark; yellow led:dark

Note: All the drive errors are shown as E5, thus check the error indicators of the outdoor units first, and find the specific error according to the code and refer to the following 2.10” Typical Troubleshooting(E5) for DC frequency conversion drive board”.

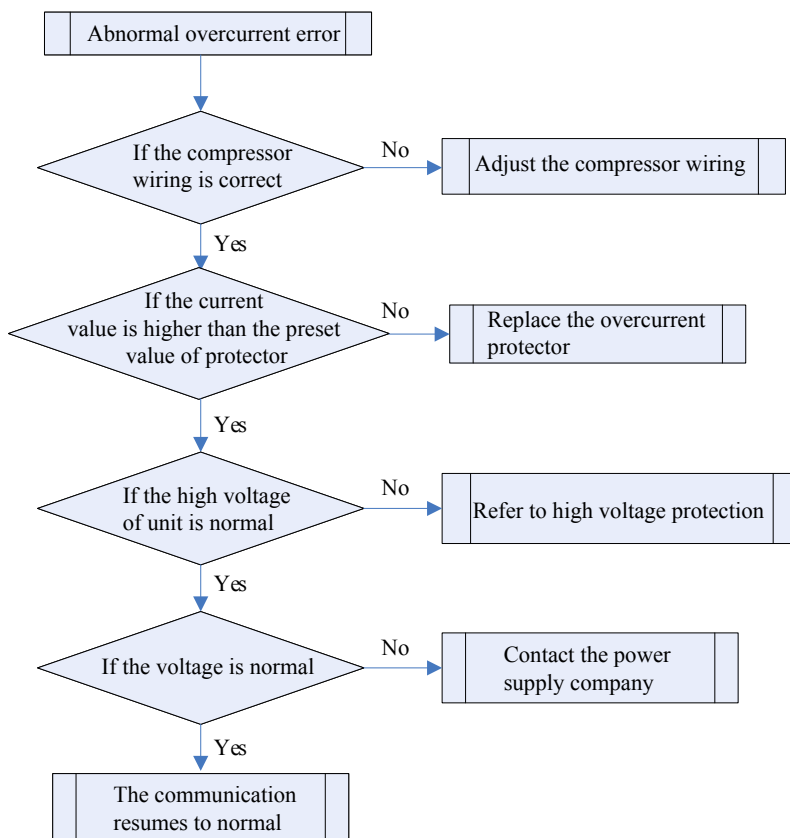

1) The LCD will display current protection upon startup.

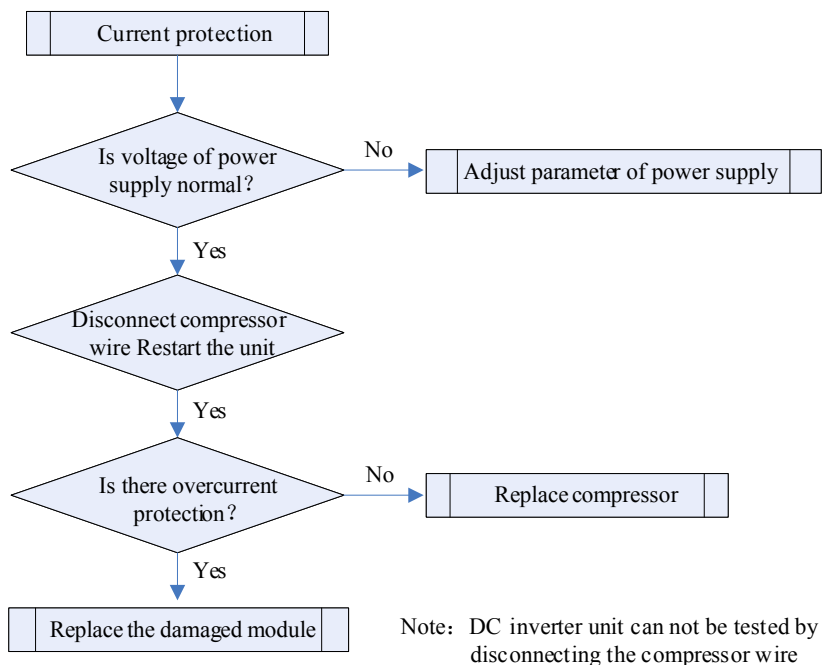

2) The LCD will display current protection after it runs for a while.

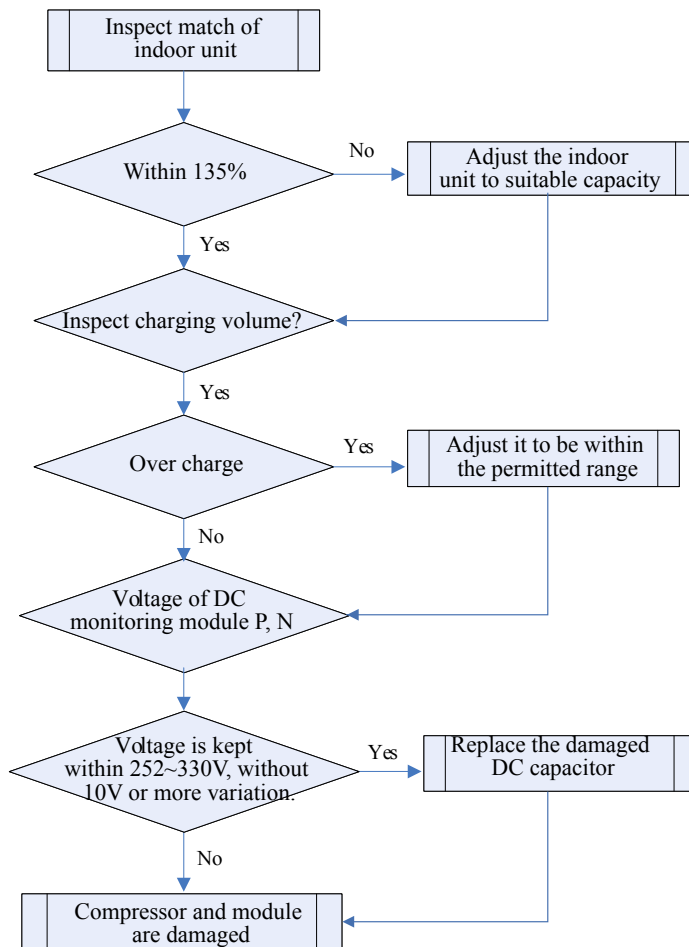

## 2.11 PFC Protection

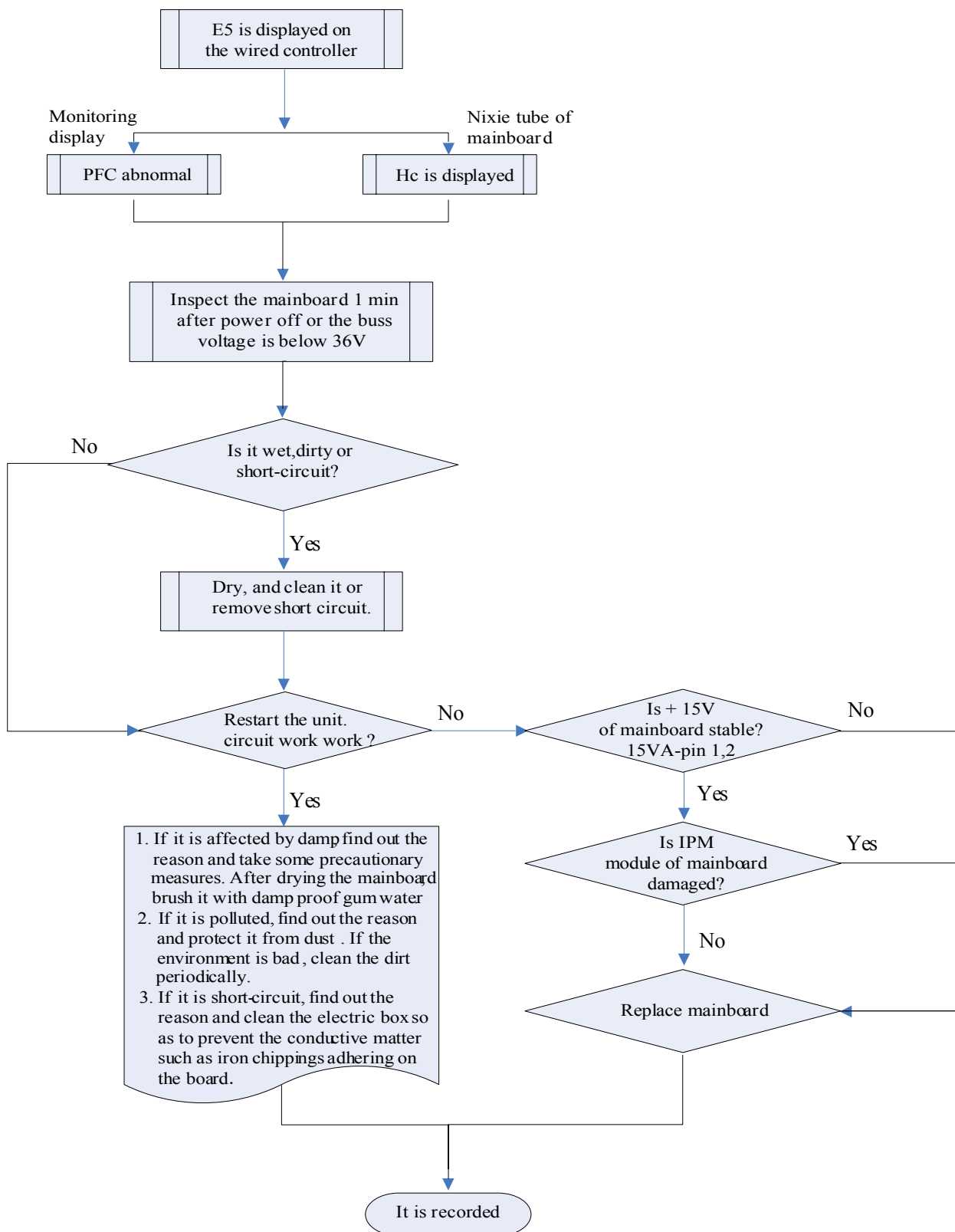

## 2.12 IPM Protection

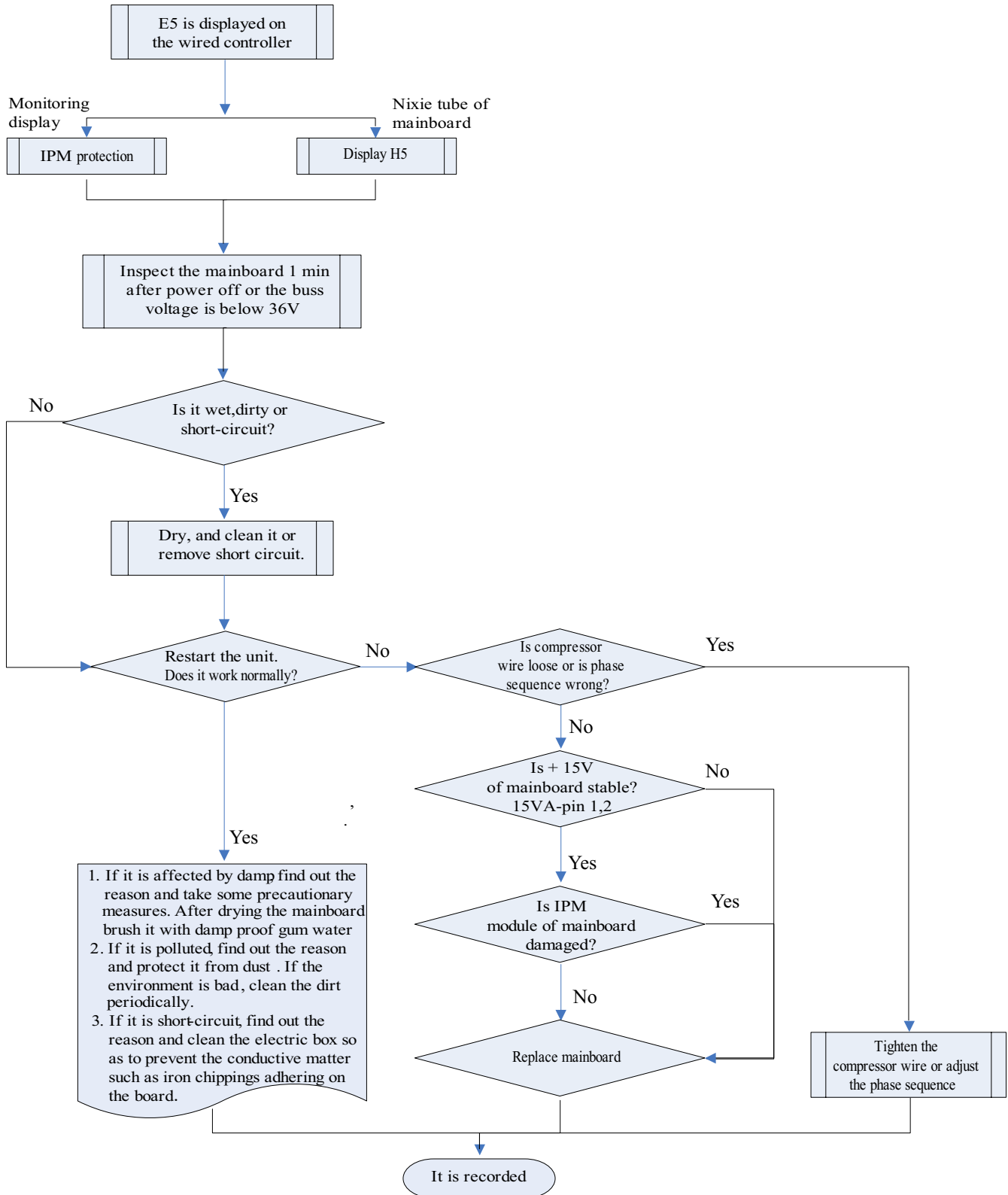

## 2.13 Trip

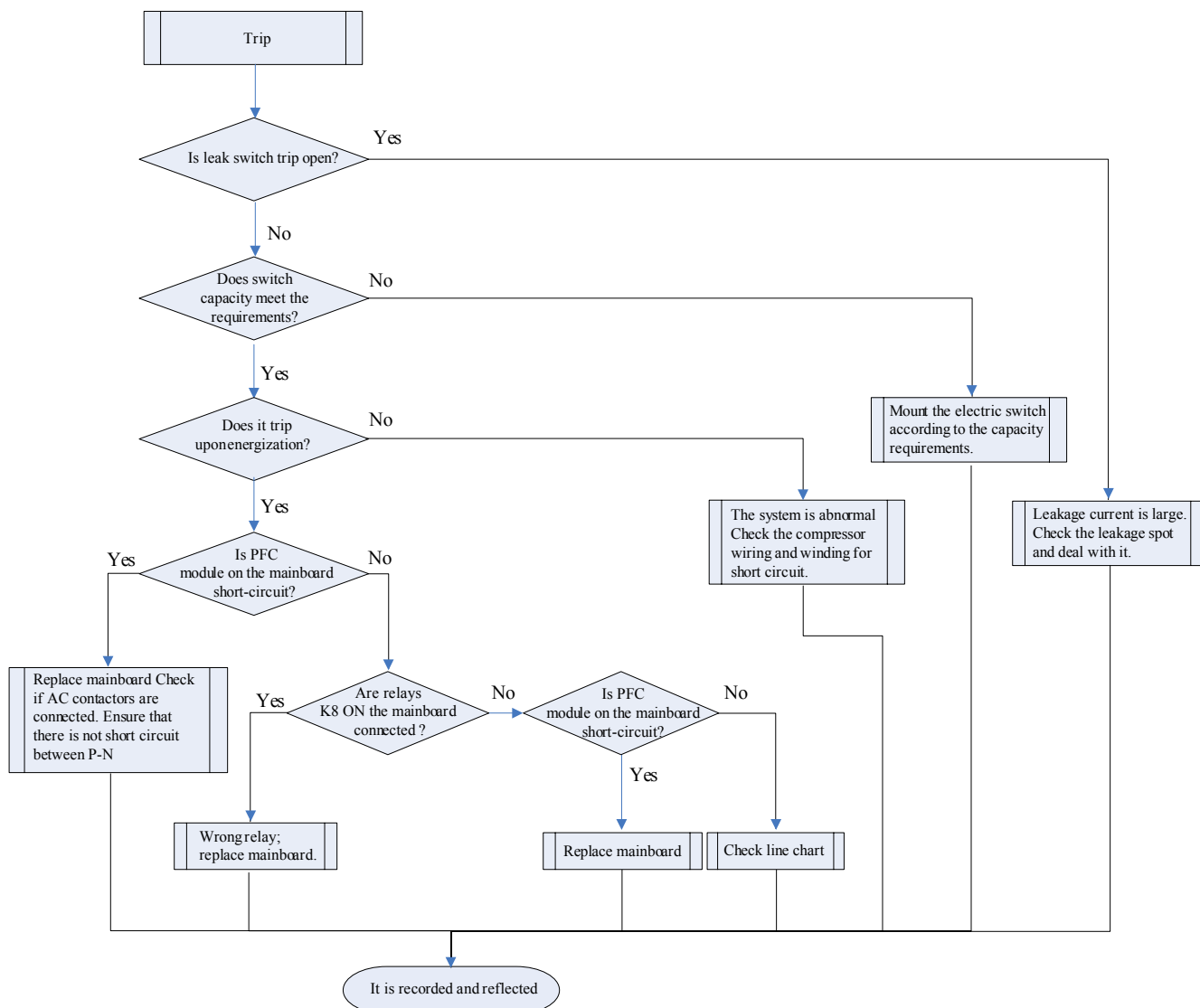

## 2.14 Superheat Protection of Radiator

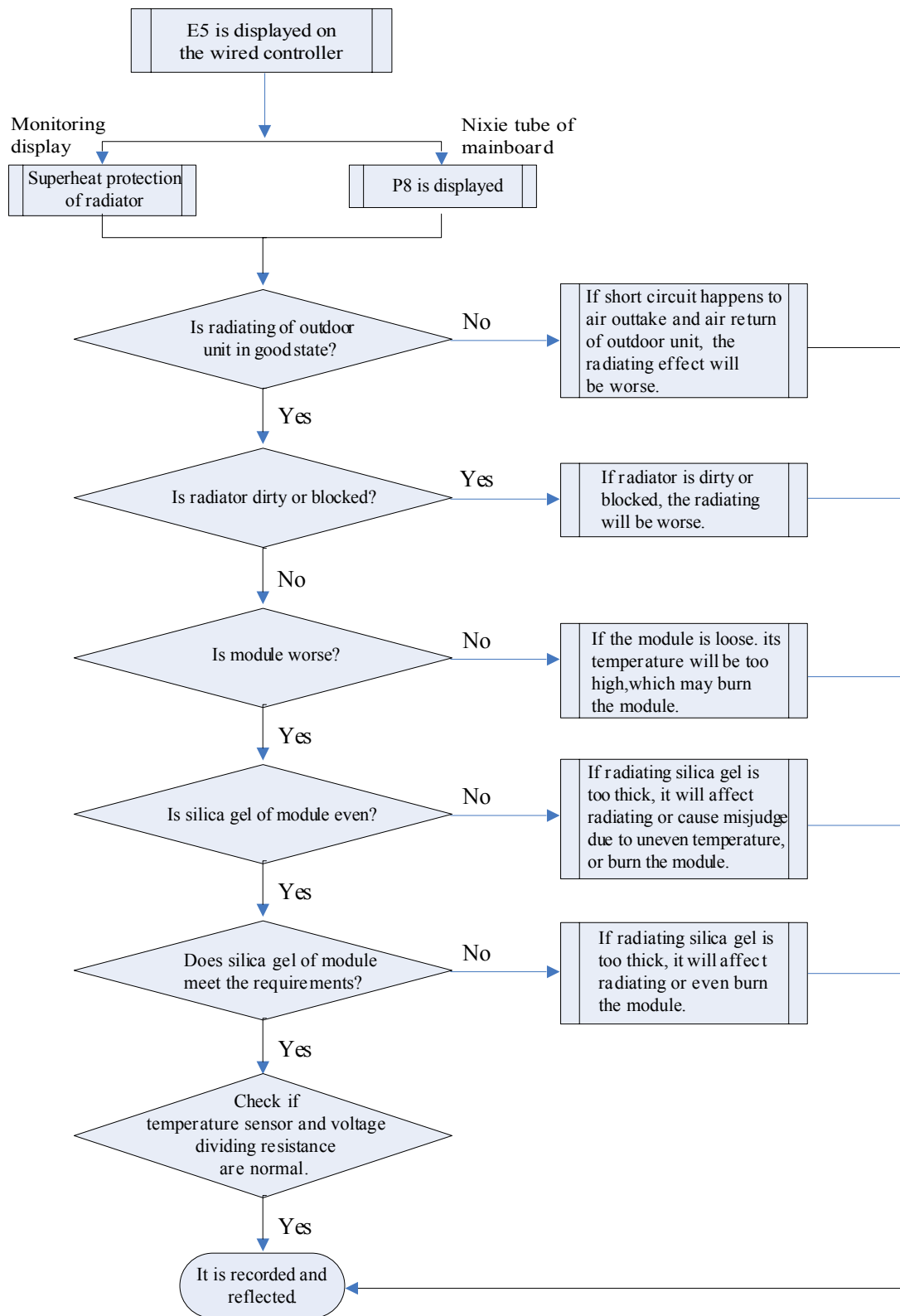

## 2.15 DC Overvoltage Protection

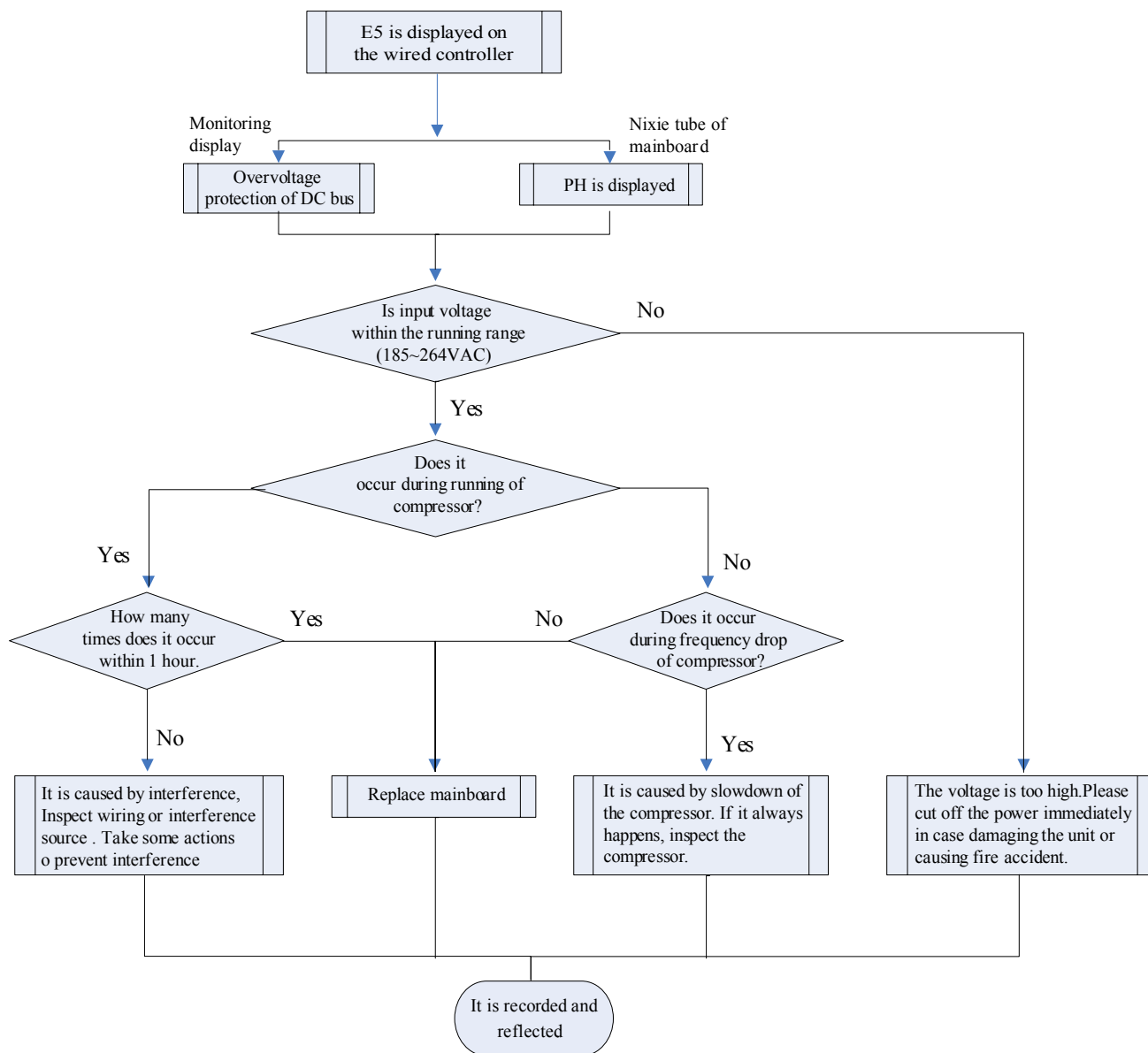



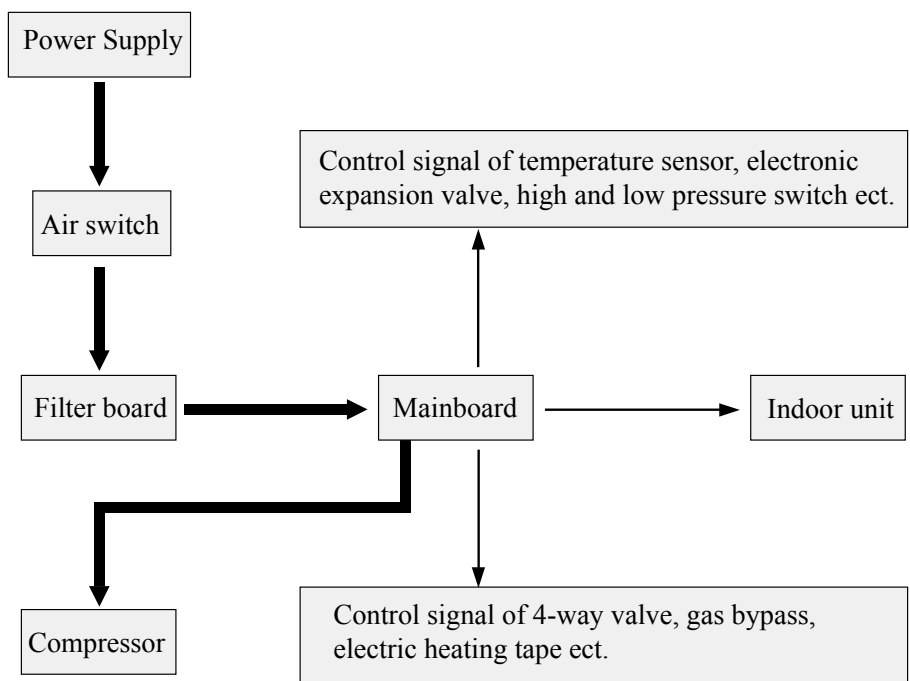

### 3 POWER DISTRIBUTION

#### 3.1 Diagram of Power Distribution



(The thick line represents power line while thin line represents the control line.)

#### 3.2 Introduction of Main Electric Parts of Inverter System

Name	Photo	Introduction
Wave filter		It is mainly used for filtering the interference of the power supply and prevent the unit from interfering the power supply so that the operation of the unit will not affect the other electric appliances such as TV.
Air switch		Connect or disconnect the main circuit,; with overcurrent and short circuit protection function

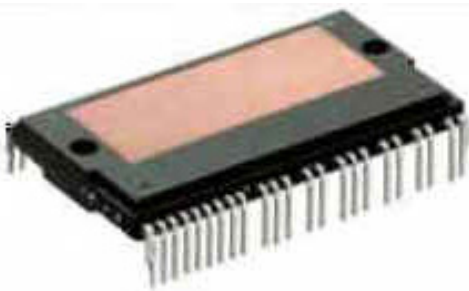
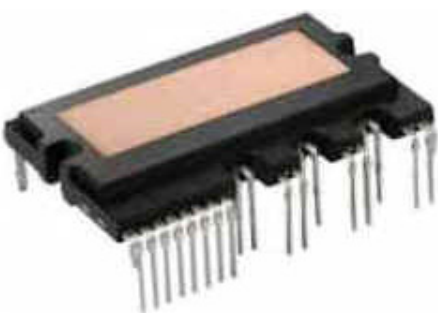
<p>IPM module</p>		<p>IPM module is integrated with 3 pair complementary IGBT tube, whose connection and disconnection are controlled through PWM so that DC bus voltage is imposed to the winding of compressor. The magnetic field will enable the rotor to rotate for running of the compressor.</p>
<p>PFC module</p>		<p>IPM module is integrated with 4 LED an 2 MOS tubes. The AC power is converted into DC power and the connection and disconnection of MOS tube are controlled through PWM so that voltage is increased,</p>

### 3.3 Wiring diagram

**NOTE:**

This drawing is just for reference; please always refer to the electric wiring stuck to the unit for actual wiring.

GMV-Pdm224W/NaB-M, GMV-Pdm280W/NaB-M,

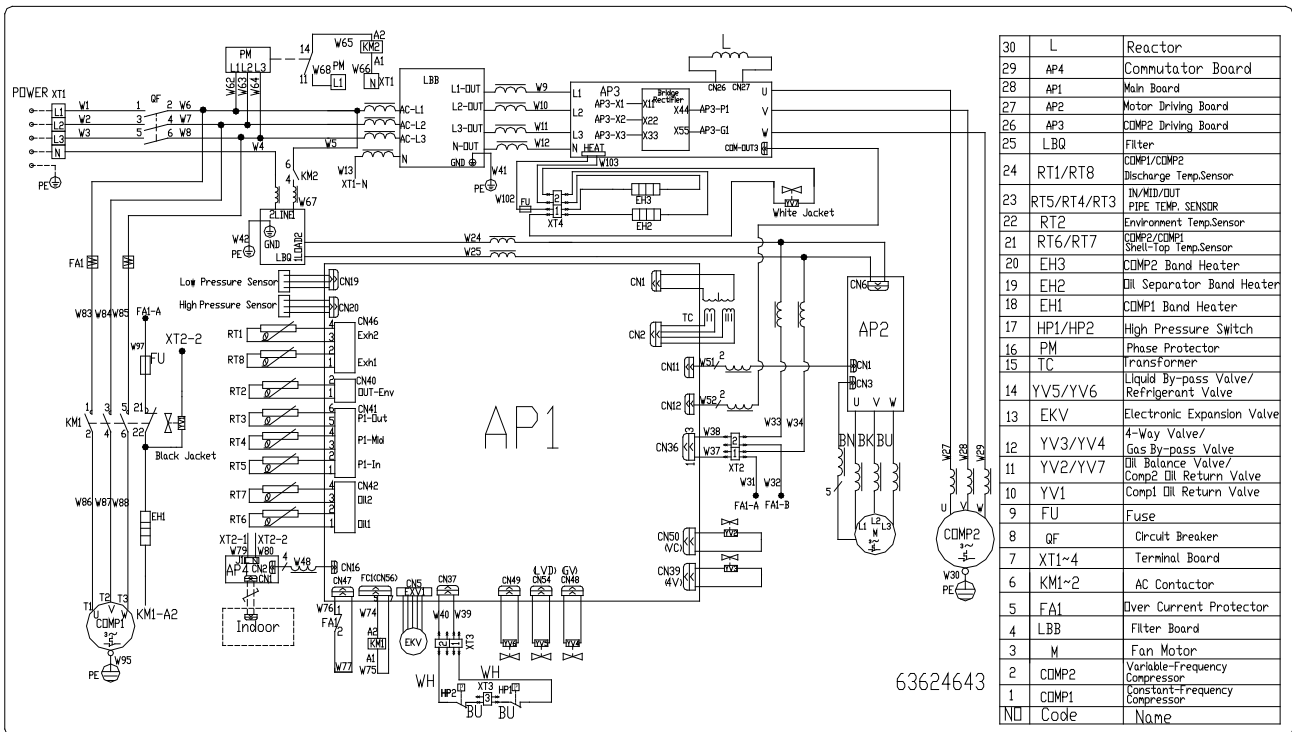

63624643

GMV-Pdm335W/NaB-M, GMV-Pdm400W/NaB-M, GMV-Pdm450W/NaB-M,

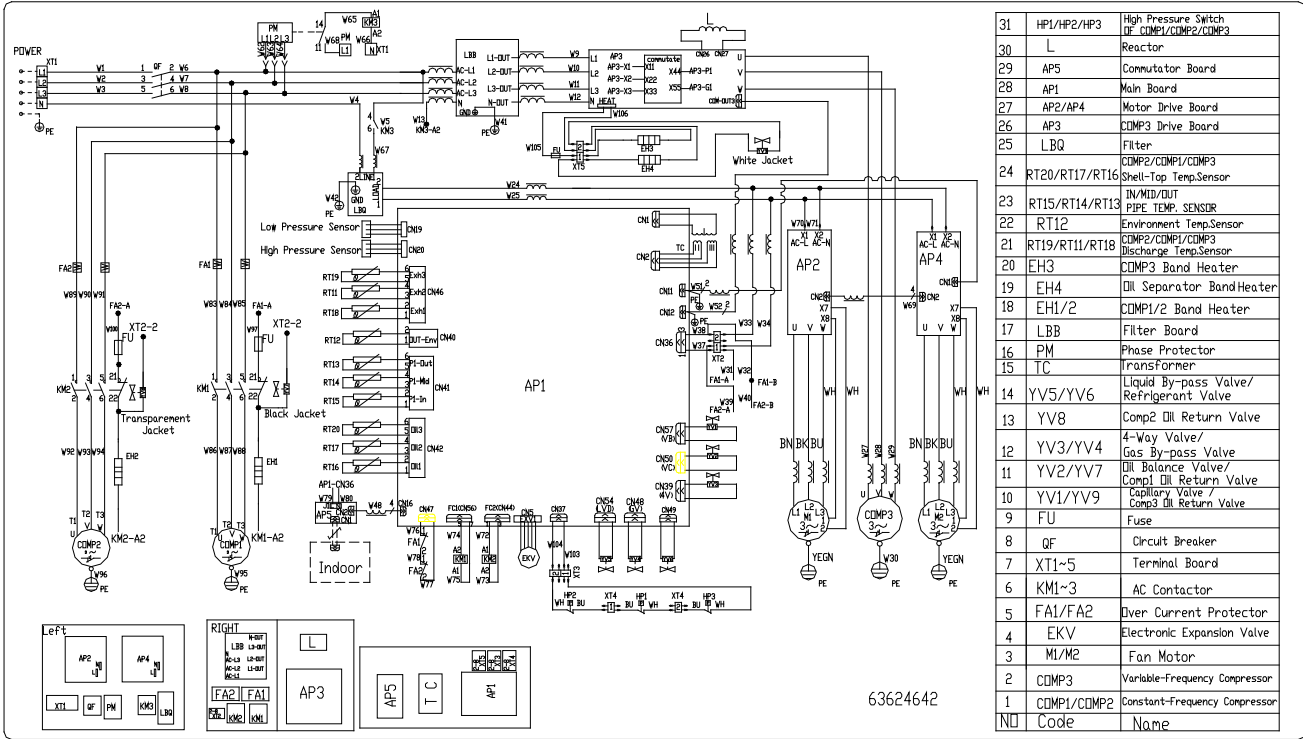

63624642

## 4 TABLE OF THE RESISTANCES OF COMMON TEMPERATURE SENSORS

### 4.1. 15kΩ

Temp. (°C)	Resistance (kΩ)	Voltage (15K/5V)	Voltage (15K/3.3V)	Temp. (°C)	Resistance (kΩ)	Voltage (15K/5V)	Voltage (15K/3.3V)
-20	144.000	0.472	0.311	71	2.523	4.280	2.825
-19	138.100	0.490	0.323	72	2.439	4.301	2.838
-18	128.600	0.522	0.345	73	2.358	4.321	2.852
-17	121.600	0.549	0.362	74	2.280	4.340	2.865
-16	115.000	0.577	0.381	75	2.205	4.359	2.877
-15	108.700	0.606	0.400	76	2.133	4.378	2.889
-14	102.900	0.636	0.420	77	2.064	4.395	2.901
-13	97.400	0.667	0.440	78	1.997	4.413	2.912
-12	92.220	0.699	0.462	79	1.933	4.429	2.923
-11	87.350	0.733	0.484	80	1.871	4.445	2.934
-10	82.750	0.767	0.506	81	1.811	4.461	2.945
-9	78.430	0.803	0.530	82	1.754	4.477	2.955
-8	74.350	0.839	0.554	83	1.699	4.491	2.964
-7	70.500	0.877	0.579	84	1.645	4.506	2.974
-6	66.880	0.916	0.605	85	1.594	4.520	2.983
-5	63.460	0.956	0.631	86	1.544	4.533	2.992
-4	60.230	0.997	0.658	87	1.497	4.546	3.001
-3	57.180	1.039	0.686	88	1.451	4.559	3.009
-2	54.310	1.082	0.714	89	1.408	4.571	3.017
-1	51.590	1.126	0.743	90	1.363	4.584	3.025
0	49.020	1.172	0.773	91	1.322	4.595	3.033
1	46.800	1.214	0.801	92	1.282	4.606	3.040
2	44.310	1.265	0.835	93	1.244	4.617	3.047
3	42.140	1.313	0.866	94	1.207	4.628	3.054
4	40.090	1.361	0.899	95	1.171	4.638	3.061
5	38.150	1.411	0.931	96	1.136	4.648	3.068
6	36.320	1.461	0.965	97	1.103	4.658	3.074
7	34.580	1.513	0.998	98	1.071	4.667	3.080
8	32.940	1.564	1.033	99	1.039	4.676	3.086
9	31.380	1.617	1.067	100	1.009	4.685	3.092
10	29.900	1.670	1.102	101	0.980	4.693	3.098
11	28.510	1.724	1.138	102	0.952	4.702	3.103
12	27.180	1.778	1.174	103	0.925	4.710	3.108
13	25.920	1.833	1.210	104	0.898	4.717	3.114
14	24.730	1.888	1.246	105	0.873	4.725	3.119
15	23.600	1.943	1.282	106	0.848	4.732	3.123
16	22.530	1.998	1.319	107	0.825	4.739	3.128
17	21.510	2.054	1.356	108	0.802	4.746	3.133
18	20.540	2.110	1.393	109	0.779	4.753	3.137
19	19.630	2.166	1.429	110	0.758	4.760	3.141
20	18.750	2.222	1.467	111	0.737	4.766	3.145
21	17.930	2.278	1.503	112	0.717	4.772	3.150
22	17.140	2.334	1.540	113	0.697	4.778	3.153
23	16.390	2.389	1.577	114	0.678	4.784	3.157

24	15.680	2.445	1.613	115	0.660	4.789	3.161
25	15.000	2.500	1.650	116	0.642	4.795	3.165
26	14.360	2.554	1.686	117	0.625	4.800	3.168
27	13.740	2.610	1.722	118	0.608	4.805	3.171
28	13.160	2.663	1.758	119	0.592	4.810	3.175
29	12.600	2.717	1.793	120	0.577	4.815	3.178
30	12.070	2.771	1.829	121	0.561	4.820	3.181
31	11.570	2.823	1.863	122	0.547	4.824	3.184
32	11.090	2.875	1.897	123	0.532	4.829	3.187
33	10.630	2.926	1.931	124	0.519	4.833	3.190
34	10.200	2.976	1.964	125	0.505	4.837	3.192
35	9.779	3.027	1.998	126	0.492	4.841	3.195
36	9.382	3.076	2.030	127	0.480	4.845	3.198
37	9.003	3.125	2.062	128	0.467	4.849	3.200
38	8.642	3.172	2.094	129	0.456	4.853	3.203
39	8.297	3.219	2.125	130	0.444	4.856	3.205
41	7.653	3.311	2.185	131	0.433	4.860	3.207
42	7.352	3.355	2.215	132	0.422	4.863	3.210
43	7.065	3.399	2.243	133	0.412	4.866	3.212
44	6.791	3.442	2.272	134	0.401	4.870	3.214
45	6.529	3.484	2.299	135	0.391	4.873	3.216
46	6.278	3.525	2.326	136	0.382	4.876	3.218
47	6.038	3.565	2.353	137	0.372	4.879	3.220
48	5.809	3.604	2.379	138	0.363	4.882	3.222
49	5.589	3.643	2.404	139	0.355	4.885	3.224
50	5.379	3.680	2.429	140	0.346	4.887	3.226
51	5.179	3.717	2.453	141	0.338	4.890	3.227
52	4.986	3.753	2.477	142	0.330	4.892	3.229
53	4.802	3.787	2.500	143	0.322	4.895	3.231
54	4.625	3.822	2.522	144	0.314	4.897	3.232
55	4.456	3.855	2.544	145	0.307	4.900	3.234
56	4.294	3.887	2.566	146	0.299	4.902	3.235
57	4.139	3.919	2.586	147	0.292	4.904	3.237
58	3.990	3.949	2.607	148	0.286	4.907	3.238
59	3.848	3.979	2.626	149	0.279	4.909	3.240
60	3.711	4.008	2.646	150	0.273	4.911	3.241
61	3.579	4.037	2.664	151	0.266	4.913	3.242
62	3.454	4.064	2.682	152	0.261	4.914	3.244
63	3.333	4.091	2.700	153	0.254	4.917	3.245
64	3.217	4.117	2.717	154	0.248	4.919	3.246
65	3.105	4.143	2.734	155	0.243	4.920	3.247
66	2.998	4.167	2.750	156	0.237	4.922	3.249
67	2.898	4.190	2.766	157	0.232	4.924	3.250
68	2.797	4.214	2.781	158	0.227	4.926	3.251
69	2.702	4.237	2.796	159	0.222	4.927	3.252
70	2.611	4.259	2.811	160	0.217	4.929	3.253

#### 4.2. 20kΩ

Temp. (°C)	Resistance (kΩ)	Volt. (20K/5V)	Volt. (20K/3.3V)	Temp. (°C)	Resistance (kΩ)	Volt. (20K/5V)	Volt. (20K/3.3V)
-30	361.8	0.262	0.173	66	3.998	4.167	2.750
-29	339.8	0.278	0.183	67	3.861	4.191	2.766
-28	319.2	0.295	0.195	68	3.729	4.214	2.781
-27	300	0.313	0.206	69	3.603	4.237	2.796
-26	282.2	0.331	0.218	70	3.481	4.259	2.811
-25	265.5	0.350	0.231	71	3.364	4.280	2.825
-24	249.9	0.371	0.245	72	3.252	4.301	2.838
-23	235.3	0.392	0.259	73	3.144	4.321	2.852
-22	221.6	0.414	0.273	74	3.04	4.340	2.865
-21	208.9	0.437	0.288	75	2.94	4.359	2.877
-20	196.9	0.461	0.304	76	2.844	4.378	2.889
-19	181.4	0.497	0.328	77	2.752	4.395	2.901
-18	171.4	0.522	0.345	78	2.663	4.412	2.912
-17	162.1	0.549	0.362	79	2.577	4.429	2.923
-16	153.3	0.577	0.381	80	2.495	4.445	2.934
-15	145	0.606	0.400	81	2.415	4.461	2.944
-14	137.2	0.636	0.420	82	2.339	4.476	2.954
-13	129.9	0.667	0.440	83	2.265	4.491	2.964
-12	123	0.699	0.462	84	2.194	4.506	2.974
-11	116.5	0.733	0.484	85	2.125	4.520	2.983
-10	110.3	0.767	0.507	86	2.059	4.533	2.992
-9	104.6	0.803	0.530	87	1.996	4.546	3.001
-8	99.13	0.839	0.554	88	1.934	4.559	3.009
-7	94	0.877	0.579	89	1.875	4.571	3.017
-6	89.17	0.916	0.605	90	1.818	4.583	3.025
-5	84.61	0.956	0.631	91	1.763	4.595	3.033
-4	80.31	0.997	0.658	92	1.71	4.606	3.040
-3	76.24	1.039	0.686	93	1.658	4.617	3.047
-2	72.41	1.082	0.714	94	1.609	4.628	3.054
-1	68.79	1.126	0.743	95	1.561	4.638	3.061
0	65.37	1.171	0.773	96	1.515	4.648	3.068
1	62.13	1.218	0.804	97	1.47	4.658	3.074
2	59.08	1.265	0.835	98	1.427	4.667	3.080
3	56.19	1.313	0.866	99	1.386	4.676	3.086
4	53.46	1.361	0.898	100	1.346	4.685	3.092
5	50.87	1.411	0.931	101	1.307	4.693	3.098
6	48.42	1.462	0.965	102	1.269	4.702	3.103
7	46.11	1.513	0.998	103	1.233	4.710	3.108
8	43.92	1.564	1.033	104	1.198	4.717	3.114
9	41.84	1.617	1.067	105	1.164	4.725	3.119
10	39.87	1.670	1.102	106	1.131	4.732	3.123
11	38.01	1.724	1.138	107	1.099	4.740	3.128
12	36.24	1.778	1.174	108	1.069	4.746	3.133
13	34.57	1.833	1.209	109	1.039	4.753	3.137
14	32.98	1.888	1.246	110	1.01	4.760	3.141
15	31.47	1.943	1.282	111	0.9825	4.766	3.145
16	30.04	1.998	1.319	112	0.9556	4.772	3.150
17	28.68	2.054	1.356	113	0.9295	4.778	3.153

18	27.39	2.110	1.393	114	0.9043	4.784	3.157
19	26.17	2.166	1.429	115	0.8799	4.789	3.161
20	25.01	2.222	1.466	116	0.8562	4.795	3.165
21	23.9	2.278	1.503	117	0.8333	4.800	3.168
22	22.85	2.334	1.540	118	0.8111	4.805	3.171
23	21.85	2.389	1.577	119	0.7895	4.810	3.175
24	20.9	2.445	1.614	120	0.7687	4.815	3.178
25	20	2.500	1.650	121	0.7485	4.820	3.181
26	19.14	2.555	1.686	122	0.7289	4.824	3.184
27	18.32	2.610	1.722	123	0.7099	4.829	3.187
28	17.55	2.663	1.758	124	0.6915	4.833	3.190
29	16.8	2.717	1.793	125	0.6736	4.837	3.192
30	16.1	2.770	1.828	126	0.6563	4.841	3.195
31	15.43	2.822	1.863	127	0.6395	4.845	3.198
32	14.79	2.874	1.897	128	0.6232	4.849	3.200
33	14.18	2.926	1.931	129	0.6074	4.853	3.203
34	13.59	2.977	1.965	130	0.5921	4.856	3.205
35	13.04	3.027	1.998	131	0.5772	4.860	3.207
36	12.51	3.076	2.030	132	0.5627	4.863	3.210
37	12	3.125	2.063	133	0.5487	4.866	3.212
38	11.52	3.173	2.094	134	0.5351	4.870	3.214
39	11.06	3.220	2.125	135	0.5219	4.873	3.216
40	10.62	3.266	2.155	136	0.509	4.876	3.218
41	10.2	3.311	2.185	137	0.4966	4.879	3.220
42	9.803	3.355	2.215	138	0.4845	4.882	3.222
43	9.42	3.399	2.243	139	0.4727	4.885	3.224
44	9.054	3.442	2.272	140	0.4613	4.887	3.226
45	8.705	3.484	2.299	141	0.4502	4.890	3.227
46	8.37	3.525	2.326	142	0.4394	4.893	3.229
47	8.051	3.565	2.353	143	0.4289	4.895	3.231
48	7.745	3.604	2.379	144	0.4187	4.897	3.232
49	7.453	3.643	2.404	145	0.4088	4.900	3.234
50	7.173	3.680	2.429	146	0.3992	4.902	3.235
51	6.905	3.717	2.453	147	0.3899	4.904	3.237
52	6.648	3.753	2.477	148	0.3808	4.907	3.238
53	6.403	3.787	2.500	149	0.3719	4.909	3.240
54	6.167	3.822	2.522	150	0.3633	4.911	3.241
55	5.942	3.855	2.544	151	0.3549	4.913	3.242
56	5.726	3.887	2.565	152	0.3468	4.915	3.244
57	5.519	3.919	2.586	153	0.3389	4.917	3.245
58	5.32	3.949	2.607	154	0.3312	4.919	3.246
59	5.13	3.979	2.626	155	0.3237	4.920	3.247
60	4.948	4.008	2.646	156	0.3164	4.922	3.249
61	4.773	4.037	2.664	157	0.3093	4.924	3.250
62	4.605	4.064	2.682	158	0.3024	4.926	3.251
63	4.443	4.091	2.700	159	0.2956	4.927	3.252
64	4.289	4.117	2.717	160	0.2891	4.929	3.253
65	4.14	4.143	2.734				

### 4.3. 50kΩ

Temp. (°C)	Resistance (kΩ)	Volt. (10K/5V)	Volt. (10K/3.3V)	Tem. (°C)	Resistance (kΩ)	Volt. (10K/5V)	Volt. (10K/3.3V)
-30	911.56	0.054	0.036	61	11.736	2.300	1.518
-29	853.66	0.058	0.038	62	11.322	2.345	1.548
-28	799.98	0.062	0.041	63	10.925	2.389	1.577
-27	750.18	0.066	0.043	64	10.544	2.434	1.606
-26	703.92	0.070	0.046	65	10.178	2.478	1.635
-25	660.93	0.075	0.049	66	9.8269	2.522	1.664
-24	620.94	0.079	0.052	67	9.4896	2.565	1.693
-23	583.72	0.084	0.056	68	9.1655	2.609	1.722
-22	549.04	0.089	0.059	69	8.9542	2.638	1.741
-21	516.71	0.095	0.063	70	8.5551	2.695	1.778
-20	486.55	0.101	0.066	71	8.2676	2.737	1.806
-19	458.4	0.107	0.070	72	7.9913	2.779	1.834
-18	432.1	0.113	0.075	73	7.7257	2.821	1.862
-17	407.51	0.120	0.079	74	7.4702	2.862	1.889
-16	384.51	0.127	0.084	75	7.2245	2.903	1.916
-15	362.99	0.134	0.088	76	6.9882	2.943	1.943
-14	342.83	0.142	0.094	77	6.7608	2.983	1.969
-13	323.94	0.150	0.099	78	6.542	3.023	1.995
-12	306.23	0.158	0.104	79	6.3315	3.062	2.021
-11	289.61	0.167	0.110	80	6.1288	3.100	2.046
-10	274.02	0.176	0.116	81	5.9336	3.138	2.071
-9	259.37	0.186	0.123	82	5.7457	3.175	2.096
-8	245.61	0.196	0.129	83	5.5647	3.212	2.120
-7	232.67	0.206	0.136	84	5.3903	3.249	2.144
-6	220.5	0.217	0.143	85	5.2223	3.285	2.168
-5	209.05	0.228	0.151	86	5.0605	3.320	2.191
-4	198.27	0.240	0.158	87	4.9044	3.355	2.214
-3	188.12	0.252	0.167	88	4.7541	3.389	2.237
-2	178.65	0.265	0.175	89	4.6091	3.423	2.259
-1	169.68	0.278	0.184	90	4.4693	3.456	2.281
0	161.02	0.292	0.193	91	4.3345	3.488	2.302
1	153	0.307	0.202	92	4.2044	3.520	2.323
2	145.42	0.322	0.212	93	4.0789	3.551	2.344
3	138.26	0.337	0.223	94	3.9579	3.582	2.364
4	131.5	0.353	0.233	95	3.841	3.612	2.384
5	126.17	0.367	0.242	96	3.7283	3.642	2.404
6	119.08	0.387	0.256	97	3.6194	3.671	2.423
7	113.37	0.405	0.267	98	3.5143	3.700	2.442
8	107.96	0.424	0.280	99	3.4128	3.728	2.460
9	102.85	0.443	0.292	100	3.3147	3.755	2.478
10	98.006	0.463	0.306	101	3.22	3.782	2.496
11	93.42	0.483	0.319	102	3.1285	3.809	2.514
12	89.075	0.505	0.333	103	3.0401	3.834	2.531
13	84.956	0.527	0.348	104	2.9547	3.860	2.547
14	81.052	0.549	0.362	105	2.8721	3.884	2.564
15	77.349	0.572	0.378	106	2.7922	3.909	2.580
16	73.896	0.596	0.393	107	2.715	3.932	2.595



17	70.503	0.621	0.410	108	2.6404	3.956	2.611
18	67.338	0.647	0.427	109	2.5682	3.978	2.626
19	64.333	0.673	0.444	110	2.4983	4.001	2.640
20	61.478	0.700	0.462	111	2.4308	4.022	2.655
21	58.766	0.727	0.480	112	2.3654	4.044	2.669
22	56.189	0.755	0.499	113	2.3021	4.064	2.682
23	53.738	0.784	0.518	114	2.2409	4.085	2.696
24	51.408	0.814	0.537	115	2.1816	4.105	2.709
25	49.191	0.845	0.558	116	2.1242	4.124	2.722
26	47.082	0.876	0.578	117	2.0686	4.143	2.734
27	45.074	0.908	0.599	118	2.0148	4.162	2.747
28	43.163	0.941	0.621	119	1.9626	4.180	2.759
29	41.313	0.974	0.643	120	1.9123	4.197	2.770
30	39.61	1.008	0.665	121	1.8652	4.214	2.781
31	37.958	1.043	0.688	122	1.8158	4.232	2.793
32	36.384	1.078	0.711	123	1.7698	4.248	2.804
33	34.883	1.114	0.735	124	1.7253	4.264	2.814
34	33.453	1.151	0.759	125	1.6821	4.280	2.825
35	32.088	1.188	0.784	126	1.6402	4.295	2.835
36	30.787	1.226	0.809	127	1.5996	4.310	2.845
37	29.544	1.264	0.835	128	1.5602	4.325	2.855
38	28.359	1.303	0.860	129	1.522	4.340	2.864
39	27.227	1.343	0.886	130	1.485	4.354	2.873
40	26.147	1.383	0.913	131	1.449	4.367	2.882
41	25.114	1.424	0.940	132	1.4141	4.381	2.891
42	24.128	1.465	0.967	133	1.3803	4.394	2.900
43	23.186	1.507	0.994	134	1.3474	4.406	2.908
44	22.286	1.549	1.022	135	1.3155	4.419	2.916
45	21.425	1.591	1.050	136	1.2846	4.431	2.924
46	20.601	1.634	1.078	137	1.2545	4.443	2.932
47	19.814	1.677	1.107	138	1.2233	4.455	2.940
48	19.061	1.721	1.136	139	1.1969	4.466	2.947
49	18.34	1.764	1.164	140	1.1694	4.477	2.955
50	17.651	1.808	1.193	141	1.1476	4.485	2.960
51	16.99	1.853	1.223	142	1.1166	4.498	2.969
52	16.358	1.897	1.252	143	1.0913	4.508	2.975
53	15.753	1.942	1.281	144	1.0667	4.518	2.982
54	15.173	1.986	1.311	145	1.0429	4.528	2.988
55	14.618	2.031	1.340	146	1.0197	4.537	2.995
56	14.085	2.076	1.370	147	0.9971	4.547	3.001
57	13.575	2.121	1.400	148	0.9752	4.556	3.007
58	13.086	2.166	1.429	149	0.9538	4.565	3.013
59	12.617	2.211	1.459	150	0.9331	4.573	3.018
60	12.368	2.235	1.475				

## 5 FEATURES OF THE HIGHT/LOW PRESSURE SENSORS

### 5.1 Features of the High Pressure Sensors (R410a)

Temp.( °C )	Absolute Pressure(kPa)	Volt. (V)	Temp. ( °C )	Absolute Pressure(kPa)	Volt. (V)
-40	176	0.102	16	1300	1.300
-39	184	0.111	17	1337	1.340
-38	193	0.120	18	1375	1.380
-37	202	0.130	19	1413	1.421
-36	211	0.139	20	1453	1.463
-35	220	0.149	21	1493	1.506
-34	230	0.160	22	1535	1.551
-33	240	0.170	23	1577	1.596
-32	250	0.181	24	1620	1.641
-31	261	0.193	25	1664	1.688
-30	273	0.206	26	1708	1.735
-29	283	0.216	27	1754	1.784
-28	295	0.229	28	1801	1.834
-27	307	0.242	29	1848	1.884
-26	319	0.255	30	1897	1.937
-25	332	0.268	31	1946	1.989
-24	345	0.282	32	1996	2.042
-23	359	0.297	33	2048	2.098
-22	373	0.312	34	2100	2.153
-21	388	0.328	35	2153	2.210
-20	403	0.344	36	2208	2.268
-19	418	0.360	37	2263	2.327
-18	434	0.377	38	2320	2.388
-17	450	0.394	39	2377	2.448
-16	467	0.412	40	2436	2.511
-15	484	0.430	41	2495	2.574
-14	502	0.450	42	2556	2.639
-13	520	0.469	43	2618	2.705
-12	538	0.488	44	2681	2.772
-11	558	0.509	45	2745	2.841
-10	577	0.530	46	2810	2.910
-9	597	0.551	47	2876	2.980
-8	618	0.573	48	2944	3.053
-7	639	0.596	49	3013	3.126
-6	661	0.619	50	3083	3.201
-5	684	0.644	51	3154	3.277
-4	707	0.668	52	3226	3.353
-3	730	0.693	53	3300	3.432
-2	754	0.718	54	3374	3.511
-1	779	0.745	55	3450	3.592
0	804	0.772	56	3528	3.675
1	830	0.799	57	3606	3.759
2	857	0.828	58	3686	3.844
3	884	0.857	59	3767	3.930
4	912	0.887	60	3849	4.018
5	940	0.917	61	3932	4.106

6	969	0.947	62	4017	4.197
7	999	0.979	63	4103	4.288
8	1030	1.012	64	4190	4.381
9	1061	1.046	65	4278	4.475
10	1093	1.080	66	4367	4.570
11	1125	1.114	67	4457	4.666
12	1159	1.150	68	4548	4.763
13	1193	1.186	69	4639	4.860
14	1228	1.224	70	4731	4.958
15	1263	1.261	71	4893	5.130

## 5.2 Features of the Low Pressure Sensors (R410a)

Temp.( °C )	Absolute Pressure(kPa)	Volt. (V)	Temp. ( °C )	Absolute Pressure(kPa)	Volt. (V)
-70	36	0.369	-14	502	1.301
-69	38	0.373	-13	520	1.337
-68	40	0.377	-12	538	1.373
-67	43	0.383	-11	558	1.413
-66	46	0.389	-10	577	1.451
-65	48	0.393	-9	597	1.491
-64	51	0.399	-8	618	1.533
-63	54	0.405	-7	639	1.575
-62	57	0.411	-6	661	1.619
-61	61	0.419	-5	684	1.665
-60	64	0.425	-4	707	1.711
-59	68	0.433	-3	730	1.757
-58	72	0.441	-2	754	1.805
-57	76	0.449	-1	799	1.895
-56	80	0.457	0	804	1.905
-55	84	0.465	1	830	1.957
-54	89	0.475	2	857	2.011
-53	94	0.485	3	884	2.065
-52	99	0.495	4	912	2.121
-51	104	0.505	5	940	2.177
-50	109	0.515	6	969	2.235
-49	115	0.527	7	999	2.295
-48	121	0.539	8	1030	2.357
-47	127	0.551	9	1061	2.419
-46	133	0.563	10	1096	2.489
-45	140	0.577	11	1125	2.547
-44	146	0.589	12	1159	2.615
-43	154	0.605	13	1193	2.683
-42	161	0.619	14	1228	2.753
-41	168	0.633	15	1263	2.823
-40	176	0.649	16	1300	2.897
-39	184	0.665	17	1337	2.971
-38	193	0.683	18	1375	3.047
-37	202	0.701	19	1413	3.123
-36	211	0.719	20	1453	3.203

-35	220	0.737	21	1493	3.283
-34	230	0.757	22	1535	3.367
-33	240	0.777	23	1577	3.451
-32	250	0.797	24	1620	3.537
-31	261	0.819	25	1664	3.625
-30	272	0.841	26	1708	3.713
-29	283	0.863	27	1754	3.805
-28	295	0.887	28	1801	3.899
-27	307	0.911	29	1848	3.993
-26	319	0.935	30	1897	4.091
-25	332	0.961	31	1946	4.189
-24	345	0.987	32	1996	4.289
-23	359	1.015	33	2048	4.393
-22	373	1.043	34	2100	4.497
-21	388	1.073	35	2153	4.603
-20	403	1.103	36	2208	4.713
-19	418	1.133	37	2263	4.823
-18	434	1.165	38	2320	4.937
-17	450	1.197	39	2377	5.051
-16	467	1.231	40	2439	5.175
-15	484	1.265			

## 6 AFTER-SALES EMERGENCY MEASURES

When some unrecoverable fault occurs to one module which is connected with several others in parallel, the following emergency measures are recommended to guarantee the heating or cooling capacity of the indoor units and the service life of modules except the faulted one are not affected.

Step 1: set all indoor units under "Off" mode and cut off the power supply to the indoor and outdoor units.

Step 2: shut off all cutoff valves of the faulted outdoor unit, including the cutoff valves of the liquid/gas pipe as well as the oil balancing valve.

Step 3: cut off the air switch of the module.

Step 4: remove the communication line between the faulted module and other modules which are still kept connected through the communication line.

Step 5: readjust the address and quantity settings on the main board of the modules except the faulted one.

Step 6: power and restart the unit

## 7 DISASSEMBLY AND ASSEMBLY PROCEDURE OF MAIN PARTS

### 7. 1 Outdoor Unit

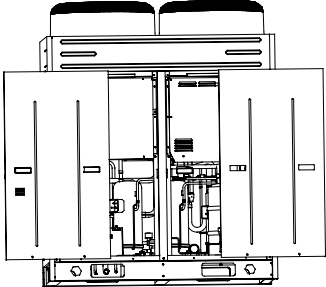
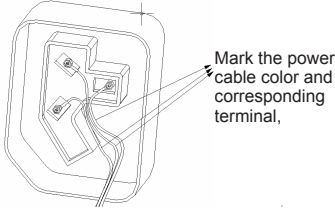
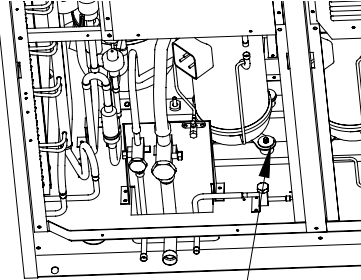
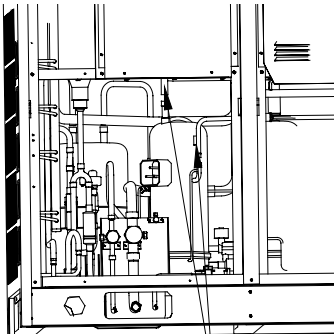
Removal and Installation of Compressor		
Remark: Before removing the compressor, make sure that there is no refrigerant inside the pipe system and that the power has been cut off.		
Step	Illustration	Handling Instruction
1. Remove front panel		<ul style="list-style-type: none"> <li>Loosen the 4 screws on the front panel.</li> <li>Lift the front panel to remove it. Note: there are two buckles for the left and right front panel. Do not pull the front panel directly. It is necessary to lift it before pull it.</li> </ul>
2. Remove power cord, electric heater and discharge temperature sensor		<ul style="list-style-type: none"> <li>Loosen the screw fixing the power cord.</li> <li>Disconnect the power cord.</li> <li>Pull out the electric heater and discharge temperature sensor</li> <li>Note: mark the color of the power cord and corresponding terminal.</li> </ul>
3. Remove the fixing screw of compressor	 <p>loosen the four screws</p>	<ul style="list-style-type: none"> <li>Loosen the 4 screws fixing the compressor.</li> </ul>
4. Remove the suction pipe	 <p>pull out the exhaust pipe</p>	<ul style="list-style-type: none"> <li>Heat the suction and discharge pipe by gas welding. Then remove the compressor.</li> <li>It is necessary to charge nitrogen for welding. The pressure of nitrogen is <math>0.5 \pm 0.1 \text{ kgf/cm}^2</math> (absolute pressure)</li> <li>Do not burn the surrounding matters when heating.</li> </ul>

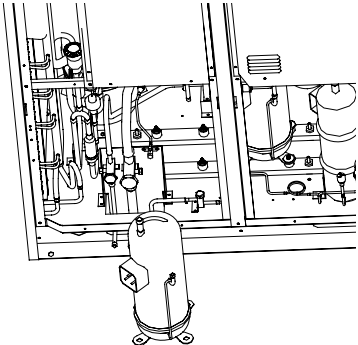
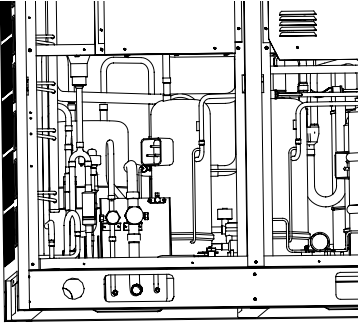
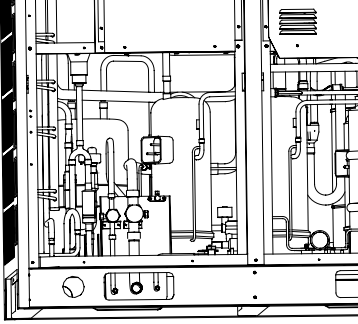
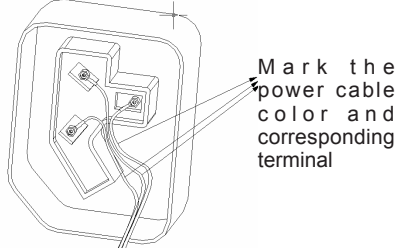
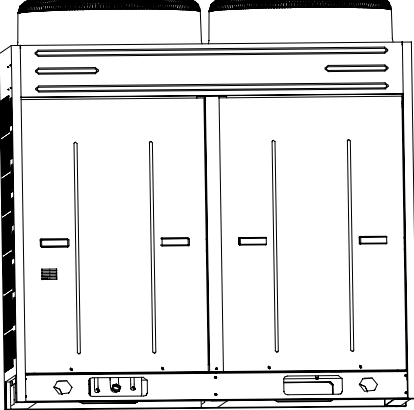
<p>5. Remove the compressor</p>		<ul style="list-style-type: none"> <li>• Move the compressor from the chassis.</li> </ul>
<p>6. Fix the new compressor on the chassis</p>		<ul style="list-style-type: none"> <li>• Put the new compressor in the right position.</li> <li>• Tighten the screws fixing the compressor.</li> <li>• The compressor can not be pside-down.</li> </ul>
<p>7. Connect the air inlet and outlet to the pipeline</p>		<ul style="list-style-type: none"> <li>•Heat the suction and discharge pipe by gas welding. Then remove the compressor.</li> <li>•It is necessary to charge nitrogen for welding. The pressure of nitrogen is <math>0.5\pm 0.1\text{kgf/cm}^2</math> (relative pressure)</li> <li>• Do not burn the surrounding matters when heating</li> </ul>
<p>8. Connect the power cord, electric heater and discharge temperature sensor</p>		<ul style="list-style-type: none"> <li>• Mount the power cord according to the disassembly sequence.</li> <li>• Tighten the screws fixing power cord.</li> <li>• Mount the electric heating tape and discharge temperature sensor.</li> </ul>
<p>9. Mount the front panel</p>		<ul style="list-style-type: none"> <li>• Check if the parts and connecting wires are well connected/</li> <li>•Fix the left and right front panels.</li> </ul>

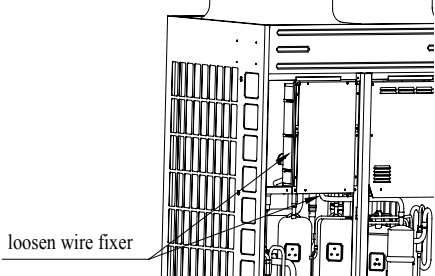
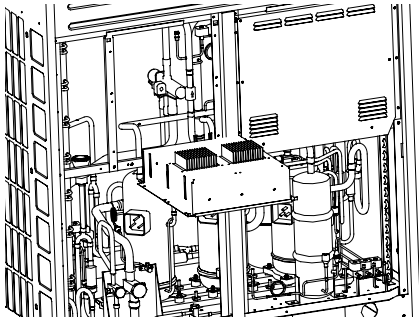
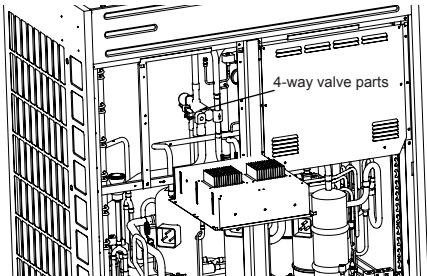
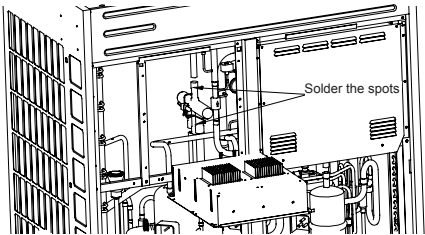
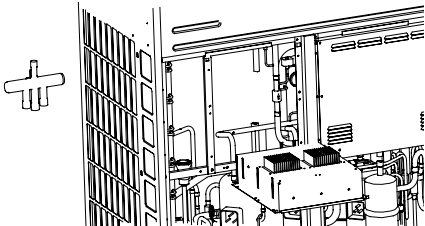
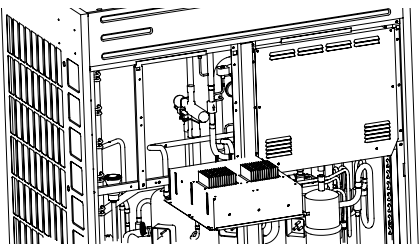
Removal and Assembly of 4-way valve		
Remark: Before removing the 4-way valve, make sure that there is no refrigerant inside the pipe system and that the power has been cut off.		
Step	Illustration	Handling Instruction
1. Loosen the left wire fixer of the left electric box and the fixing screws		<ul style="list-style-type: none"> <li>Remove the left and right front panels.</li> <li>Loosen the wire fixer of the electric box.</li> <li>Loosen the fixing screws of the left electric box.</li> </ul>
2. Remove the left electric box		<ul style="list-style-type: none"> <li>Put a support of suitable height in front of the left electric box.</li> <li>Take off the electric box and lay its front part on the support.</li> </ul>
3. Remove 4-way valve parts		<ul style="list-style-type: none"> <li>Loosen the 4-way valve parts.</li> <li>Remove the 4-way valve parts.</li> </ul>
4. Remove 4-way valve		<ul style="list-style-type: none"> <li>Heat the four nozzles of the 4-way valve by gas welding. Remove the 4-way valve</li> <li>Before solder off the 4-way valve, record the direction of 4-way valve and installing position of each nozzle. Note: do not burn the other parts during soldering.</li> </ul>
5. Remove 4-way valve from the pipe		<ul style="list-style-type: none"> <li>Remove 4-way valve from the pipeline.</li> </ul>
6. Mount 4-way valve		<ul style="list-style-type: none"> <li>Mount a new 4-way valve in the right position.</li> <li>Connect the new 4-way valve to the pipe.</li> <li>Wrap the 4-way valve with wet cloth in case of burnt gliding block and inflow of water.</li> <li>Charge nitrogen for welding, whose pressure is <math>0.5 \pm 0.1 \text{ kgf/cm}^2</math> (relative pressure).</li> </ul>

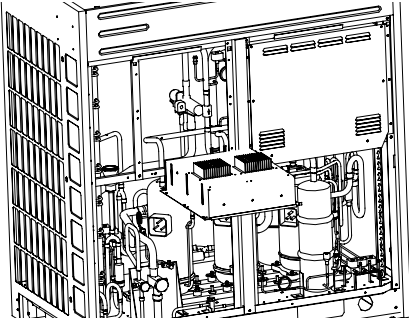
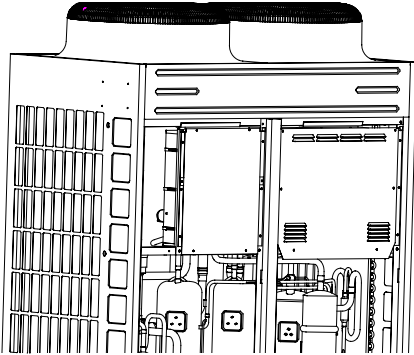
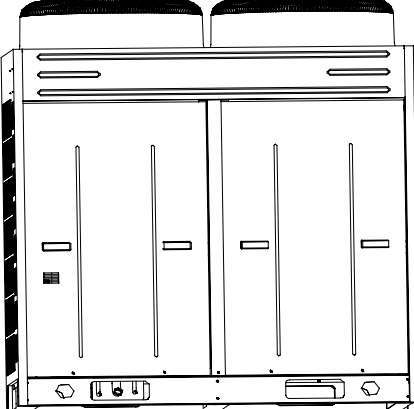
<p>7. Mount 4-way valve parts</p>		<ul style="list-style-type: none"> <li>● Mount the parts of 4-way valve on the new 4-way valve according to the disassembly sequence.</li> </ul>
<p>8. Fix electric box and the wire fixer</p>		<ul style="list-style-type: none"> <li>● Fix the screws of the electric box.</li> <li>● Tighten the wire fixer of the electric box.</li> </ul>
<p>9 Mount front panel</p>		<ul style="list-style-type: none"> <li>● Check if the parts and connecting wires are well connected.</li> <li>● .Fix the front panel.</li> </ul>

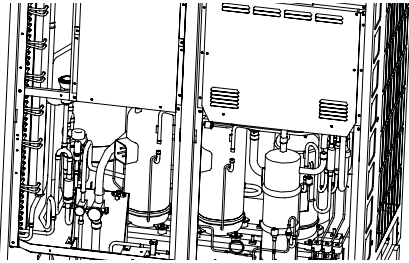
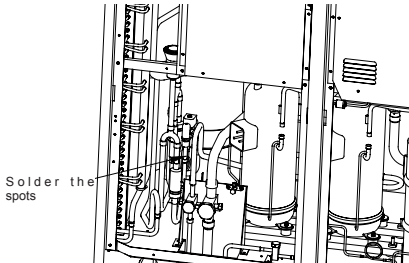
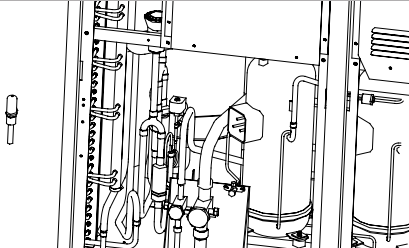
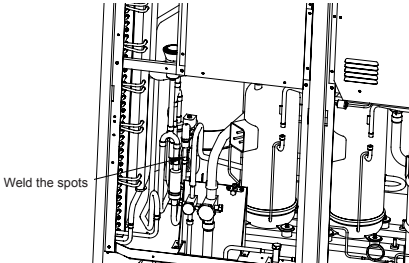
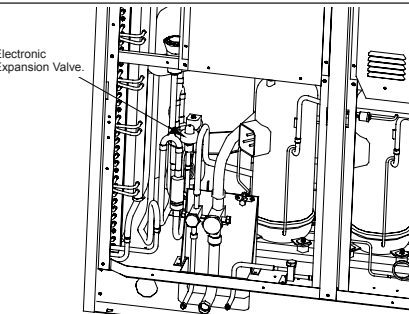

Removal and Installation of Electronic Expansion Valve		
Remark: Before removing the electronic expansion valve, make sure that there is no refrigerant inside the pipe system and that the power has been cut off.		
Step	Illustration	Handling Instruction
1. Remove the coil of electronic expansion valve		<ul style="list-style-type: none"> <li>Remove the left and right panels.</li> <li>Remove the coil of electronic expansion valve.</li> </ul>
2. Disassemble the electronic expansion valve		<ul style="list-style-type: none"> <li>Solder off the connecting pipe of electronic expansion valve.</li> </ul> <p>Note: do not burn the other parts during soldering.</p>
3. Take out the electronic expansion valve.		<ul style="list-style-type: none"> <li>Remove the electronic expansion valve.</li> </ul>
4. Replace the electronic expansion valve.		<ul style="list-style-type: none"> <li>Weld the connecting pipe of the electronic expansion valve.</li> <li>Wrap the valve with wet cloth when welding the electronic expansion valve.</li> <li>Charge nitrogen for welding, whose pressure is <math>0.5 \pm 0.1 \text{ kgf/cm}^2</math> (relative pressure).</li> </ul> <p>Note: do not burn the other parts during soldering.</p>
5. Mount the coil of the electronic expansion valve.		<ul style="list-style-type: none"> <li>Mount coil of electronic expansion valve.</li> </ul>

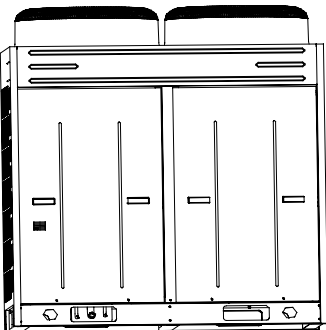
<p>6. Mount front panel</p>		<ul style="list-style-type: none"> <li>• Check if the parts and connecting wire is well mounted.</li> <li>• Fix the left and right front panels.</li> </ul>
-----------------------------	---	---

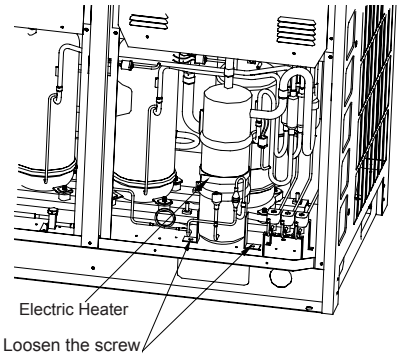
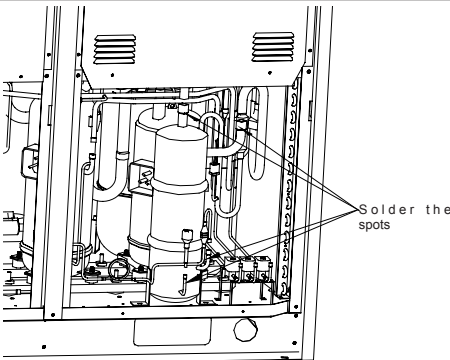
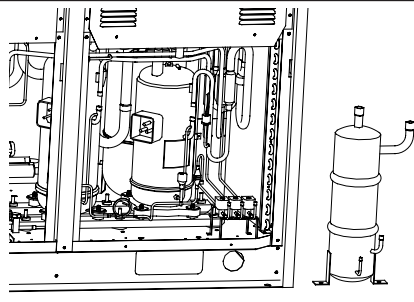
Removal and Assembly of Oil Separator		
Remark: Before removing the oil separator, make sure that there is no refrigerant inside the pipe system and that the power has been cut off.		
Step	Illustration	Handling Instruction
<p>1. Loosen fixing screw of oil separator and e-heater</p>	 <p>Electric Heater</p> <p>Loosen the screw</p>	<ul style="list-style-type: none"> <li>• Remove the left and right front panels.</li> <li>• Loosen the screws of oil separator.</li> <li>• Loosen the electric heater on the oil separator.</li> </ul>
<p>2. Disassemble oil separator</p>	 <p>Solder the spots</p>	<ul style="list-style-type: none"> <li>• Slider off the connecting pipe.</li> </ul> <p>Note: do not burn the other parts during soldering.</p>
<p>3. Remove oil separator</p>		<ul style="list-style-type: none"> <li>• Move the oil separator from the chassis.</li> </ul>

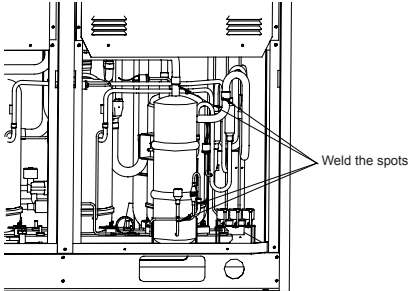
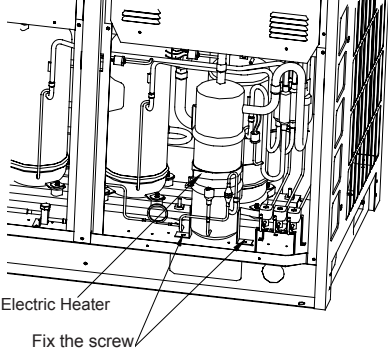
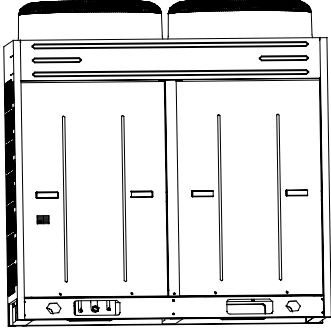
<p>4. Mount a new oil separator</p>		<ul style="list-style-type: none"> <li>●Weld the 4 connecting spots on the oil separator.</li> <li>●Charge nitrogen for welding. The pressure of nitrogen should be <math>0.5\pm 0.1\text{kgf/cm}^2</math> (relative pressure). Note: do not burn the other parts during soldering.</li> </ul>
<p>5. Mount the fixing screw of oil separator and electric heating tape</p>		<ul style="list-style-type: none"> <li>● Fix the screws of oil separator.</li> <li>● Mount electric heater.</li> </ul>
<p>6. Mount front panel</p>		<ul style="list-style-type: none"> <li>● Check if the parts and connecting wires are well connected.</li> <li>● Fix the front panel.</li> </ul>

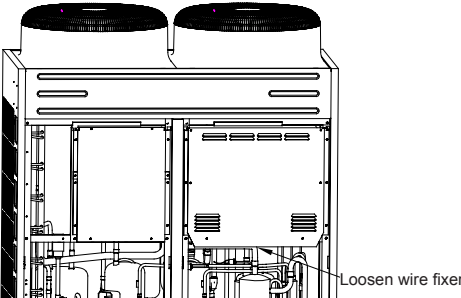
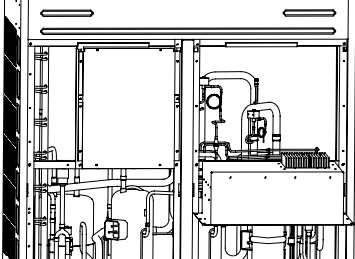
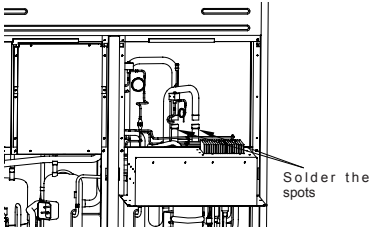
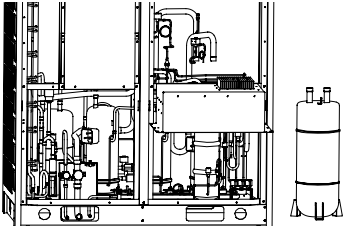
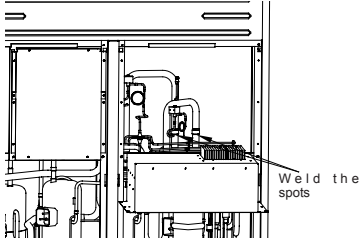
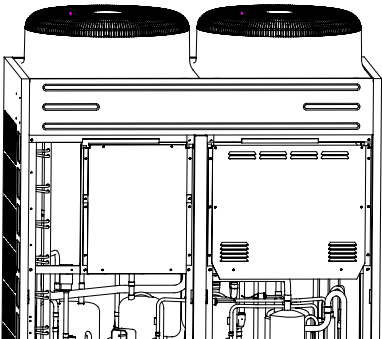
Removal and Assembly of Gas-liquid Separator		
Remark: Before removing the gas-liquid separator, make sure that there is no refrigerant inside the pipe system and that the power has been cut off.		
Step	Illustration	Handling Instruction
1. Loosen wire fixer under the right electric box and the fixing screw of electric box		<ul style="list-style-type: none"> <li>Remove the left and right front panels.</li> <li>Loosen the wire fixer under the right electric box.</li> <li>Loosen the screws fixing the right electric box.</li> </ul>
2. Remove the right electric box		<ul style="list-style-type: none"> <li>Put a support of suitable height in front of the left electric box.</li> <li>Take off the electric box and lay its front part on the support.</li> </ul>
3. Disassemble gas-liquid separator		<ul style="list-style-type: none"> <li>Heat the 2 nozzles by gas welding and remove the gas-liquid separator. Note: do not burn the other parts during soldering.</li> </ul>
4. Remove gas-liquid separator		<ul style="list-style-type: none"> <li>Adjust the connecting pipe to pull out the gas-liquid separator.</li> <li>Move out the gas-liquid separator from the electric box.</li> </ul>
5. Mount a new gas-liquid separator		<ul style="list-style-type: none"> <li>Mount the gas-liquid separator according to the position of inlet and outlet pipe. Weld the 2 connecting spots.</li> <li>Charge nitrogen for welding. The pressure of nitrogen is <math>0.5 \pm 0.1 \text{ kgf/cm}^2</math> (relative pressure). Note: do not burn the other parts during soldering.</li> </ul>
6. Mount fixing screw of gas-liquid separator and electric heating tape		<ul style="list-style-type: none"> <li>Move up the electric box and fix it.</li> <li>Tighten the wire fixer of the right electric box.</li> </ul>

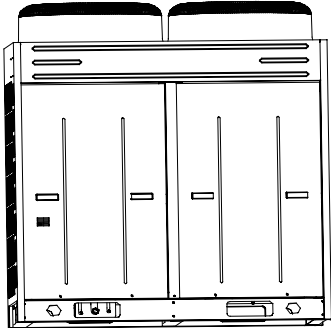
<p>7. Mount front panel</p>		<ul style="list-style-type: none"> <li>• Check if the parts and connecting wires are well connected.</li> <li>• Fix the left and right front panels.</li> </ul>
-----------------------------	---	---

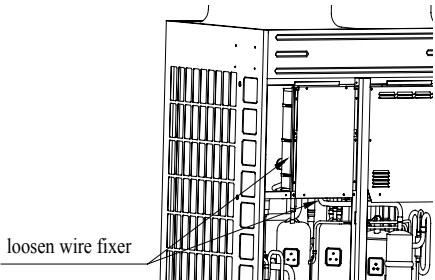
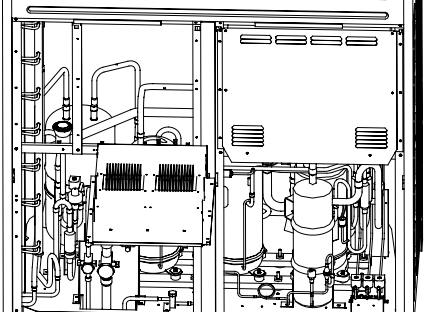
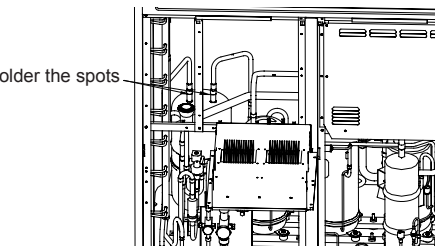
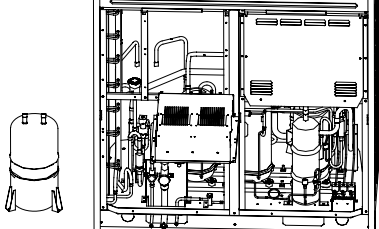
Removal and Assembly of Liquid Storage Tank		
Remark: Before removing the liquid storage tank, make sure that there is no refrigerant inside the pipe system and that the power has been cut off.		
Step	Illustration	Handling Instruction
<p>1. Loosen the wire fixer of the left electric box and the screws</p>		<ul style="list-style-type: none"> <li>• Remove the left and right front panels.</li> <li>• Loosen the left and lower wire fixers of the left electric box.</li> <li>• Loosen the screws fixing the left electric box.</li> </ul>
<p>2. Take off the left electric box</p>		<ul style="list-style-type: none"> <li>• Put a support of suitable height in front of the left electric box.</li> <li>• Take off the electric box and lay its front part on the support.</li> </ul>
<p>3. Disassemble the liquid storage tank</p>		<ul style="list-style-type: none"> <li>• Heat the 2 nozzles by gas welding and remove the gas-liquid separator. Note: do not burn the other parts during soldering.</li> </ul>
<p>4. Remove the liquid storage tank</p>		<ul style="list-style-type: none"> <li>• Adjust the connecting pipe to pull out the liquid storage tank.</li> <li>• Move out the liquid storage tank from the electric box.</li> </ul>

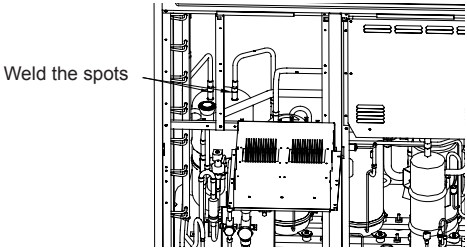
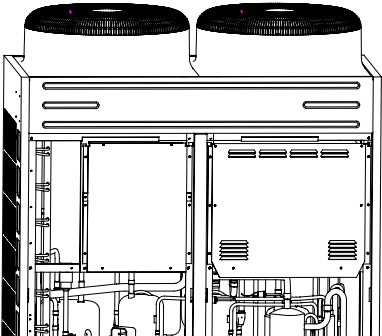
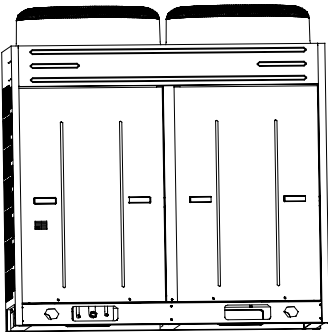
<p>5. Mount new liquid storage tank</p>	 <p>Weld the spots</p>	<ul style="list-style-type: none"> <li>• Weld the 2 connecting spots.</li> <li>• Charge nitrogen for welding. The pressure of nitrogen is <math>0.5 \pm 0.1 \text{ kgf/cm}^2</math> (relative pressure). Note: do not burn the other parts during soldering.</li> </ul>
<p>6. Fix electric box and wire fixer,</p>		<ul style="list-style-type: none"> <li>• Move up the electric box and fix it.</li> <li>• Tighten the wire fixer of the right electric box.</li> </ul>
<p>7. Mount the front panel</p>		<ul style="list-style-type: none"> <li>• Check if the parts and connecting wires are well connected.</li> <li>• Fix the left and right front panels.</li> </ul>

## 8 EXPLODED VIEWS AND PART LIST

### 8.1 Outdoor Unit

- Exploded View of GMV-Pdm224W/NaB-Mexploded views.

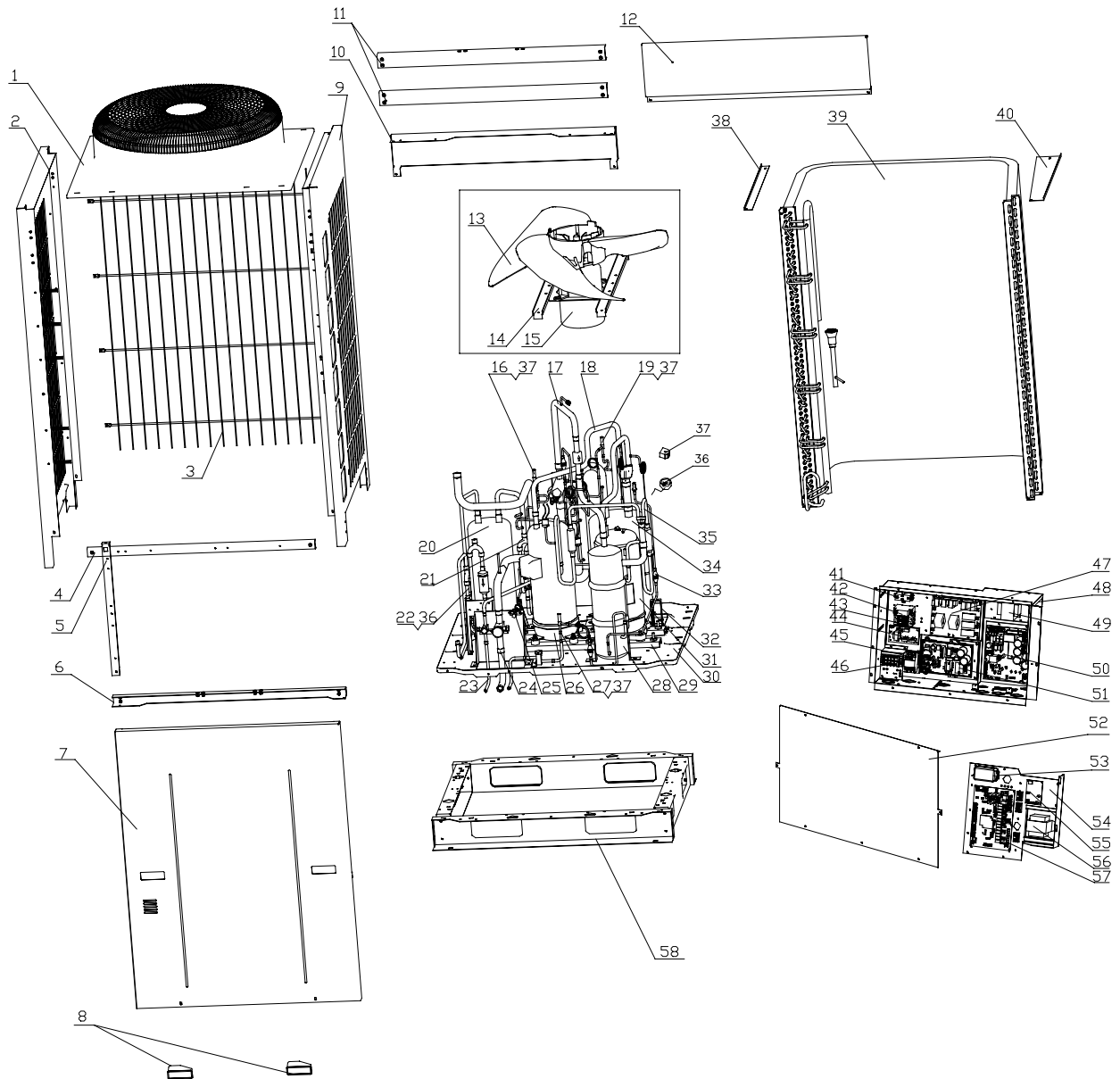

- Parts List of GMV-Pdm224W/NaB-M for CN851W1000 .

No.	Name	Code	Qty
1	Streamlined Dome	26904101	1
2	Left Side Plate Sub-Assy	01313256P	1
3	Front Grill	01238740	1
4	Supported Beam Sub-Assy	01874132P	1
5	Front Panel Supported Beam	01894113P	1
6	Mounting Rack Sub-Assy	01324120P	1
7	Front Panel Sub-Assy	01544616P	1
8	Handle	26235253	2
9	Right Side Plate	01313258P	1

10	Rear Cover Plate	01263231P	1
11	Mounting Rack	01324221P	1
12	Front Cover Board	01264223P	1
13	Axial Flow Fan	10338702	1
14	Motor Sub-Assy	0132431501P	1
15	Fan Motor	15704106	1
16	Liquid By-pass Sub-Assy	04634233	1
17	4-way Valve Sub-Assy	04144160	1
18	Suck Tube Sub-Assy	04674172	1
19	Gas By-pass Sub-Assy	04634229	1
20	Accumulator	07424152	1
21	Electromagnetic valve Sub-Assy	43044118	1
22	Electric Expansion Valve Sub-Assy	07334228	1
23	Cut-off valve Sub-Assy	07334330	1
24	Cut-off valve Sub-Assy	07130365	1
25	Gas Pressure Tested Sub-Assy	06114146	1
26	Compressor and fittings	00204124	1
27	Oil Distributed Sub-Assy	06114145	1
28	Oil Separator	07424187	1
29	Compressor Mounting Plate Sub-Assy	01324242P	1
30	Chassis Assy	01194135P	1
31	Compressor and fittings	00204116	1
32	Mounting Rack	01324222	1
33	Return OIL Sub-Assy	04324739	1
34	Gas-liquid Separator	07424148	1
35	Discharge Tube Sub-Assy	04634267	1
36	Electric expand valve fitting	4300010810	1
37	Magnet Coil	4304000407	5
38	Air Guard	01354102	1
39	Condenser Assy	0112416001	1
40	Air Guard	01354103	1
41	AC Contactor	44010245	1
42	Phase Reverse Protector	46020054	1
43	Current Breaker	45020214	1
44	Over Current Protector	46020115	1
45	AC Contactor	44010213	1
46	Terminal Board	42011051	1
47	Filter Board	30228111	1
48	Electrical Box Assy	01394839P	1
49	Reactor	43130174	1
50	Main Board	30228606	1
51	Main Board	30220025	1
52	Electric Box Cover	01424252P	1
53	Filter	43130016	1
54	Electrical Supporting Plate	01324318	1
55	Pinboard	30278301	1
56	Transformer	43110237	1
57	Main Board	30229004	1
58	Baseplate Assy	01874137P	1



● Exploded View of GMV-Pdm280W/NaB-M exploded views.

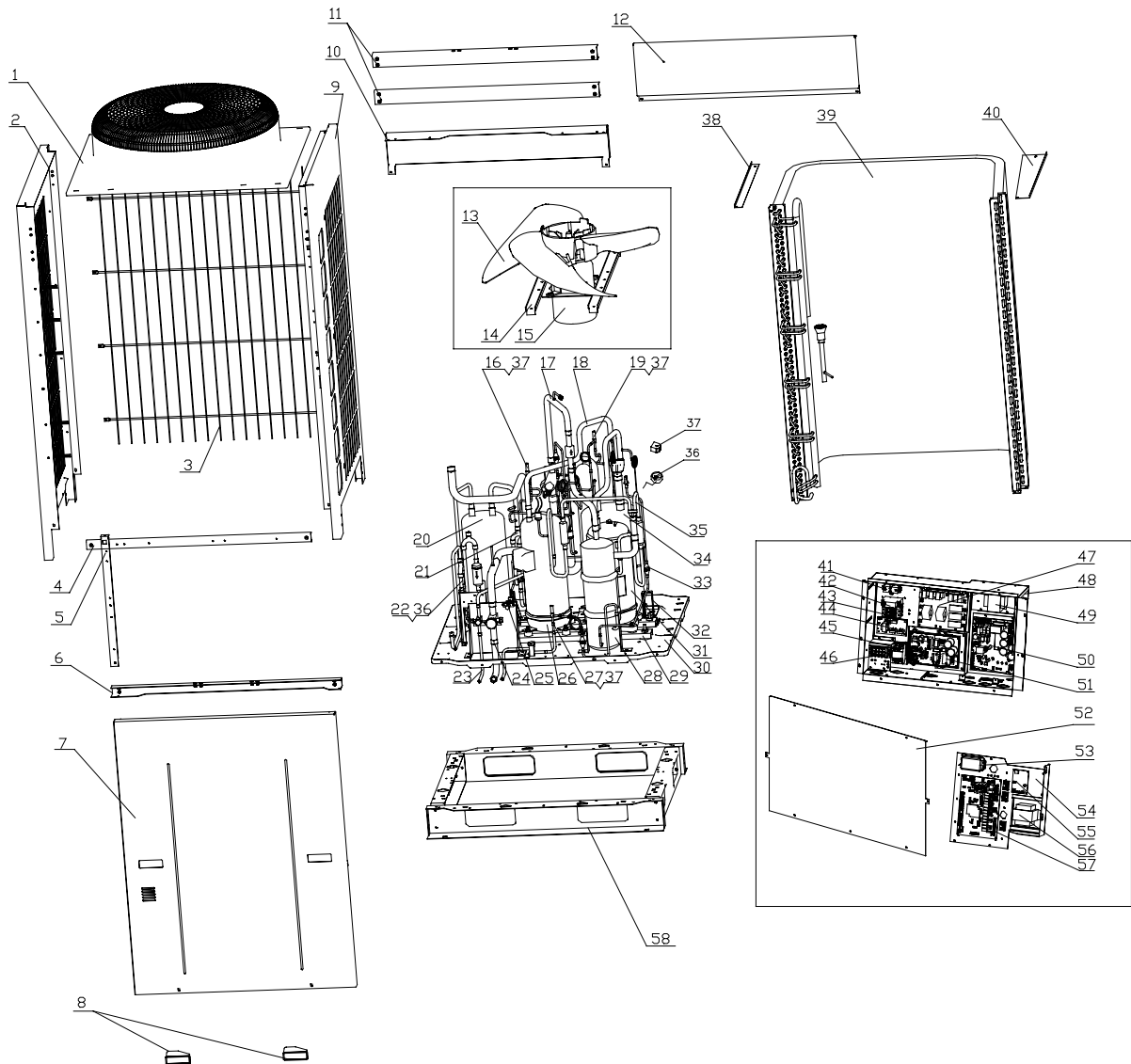

● Parts List of GMV-Pdm280W/NaB-M for CN851W1010 .

No.	Name	Code	Qty
1	Streamlined Dome	26904101	1
2	Left Side Plate Sub-Assy	01313256P	1
3	Front Grill	01238740	1
4	Supported Beam Sub-Assy	01874132P	1
5	Front Panel Supported Beam	01894113P	1
6	Mounting Rack Sub-Assy	01324120P	1
7	Front Panel Sub-Assy	01544616P	1
8	Handle	26235253	2
9	Right Side Plate	01313258P	1
10	Rear Cover Plate	01263231P	1
11	Mounting Rack	01324221P	1
12	Front Cover Board	01264223P	1
13	Axial Flow Fan	10338702	1
14	Motor Sub-Assy	0132431501P	1
15	Fan Motor	15704106	1

16	Liquid By-pass Sub-Assy	04634233	1
17	4-way Valve Sub-Assy	04144160	1
18	Suck Tube Sub-Assy	04674172	1
19	Gas By-pass Sub-Assy	04634229	1
20	Accumulator	07424152	1
21	Electromagnetic valve Sub-Assy	43044118	1
22	Electric Expansion Valve Sub-Assy	07334228	1
23	Cut-off valve Sub-Assy	07334330	1
24	Cut-off valve Sub-Assy	07130365	1
25	Gas Pressure Tested Sub-Assy	06114146	1
26	Compressor and fittings	00204124	1
27	Oil Distributed Sub-Assy	06114145	1
28	Oil Separator	07424187	1
29	Compressor Mounting Plate Sub-Assy	01324242P	1
30	Chassis Assy	01194135P	1
31	Compressor and fittings	00204116	1
32	Mounting Rack	01324222	1
33	Return OIL Sub-Assy	04324739	1
34	Gas-liquid Separator	07424148	1
35	Discharge Tube Sub-Assy	04634267	1
36	Electric expand valve fitting	4300010810	1
37	Magnet Coil	4304000407	5
38	Air Guard	01354102	1
39	Condenser Assy	0112416001	1
40	Air Guard	01354103	1
41	AC Contactor	44010245	1
42	Phase Reverse Protector	46020054	1
43	Current Breaker	45020214	1
44	Over Current Protector	46020115	1
45	AC Contactor	44010213	1
46	Terminal Board	42011051	1
47	Filter Board	30228111	1
48	Electrical Box Assy	01394839P	1
49	Reactor	43130174	1
50	Main Board	30228606	1
51	Main Board	30220025	1
52	Electric Box Cover	01424252P	1
53	Filter	43130016	1
54	Electrical Supporting Plate	01324318	1
55	Pinboard	30278301	1
56	Transformer	43110237	1
57	Main Board	30229004	1
58	Baseplate Assy	01874137P	1

● Exploded View of GMV-Pdm335W/NaB-M exploded views.

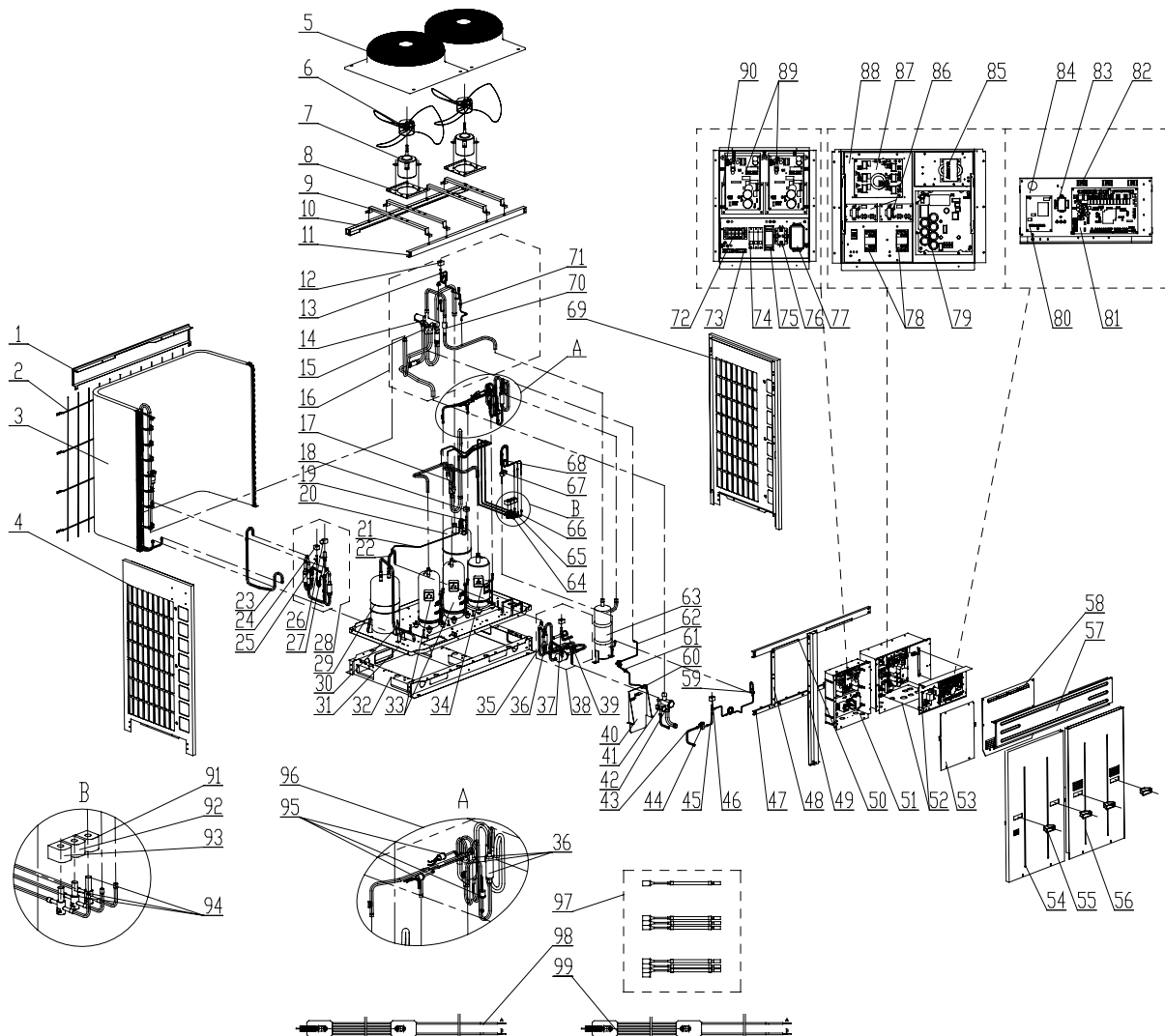

● Parts List of GMV-Pdm335W/NaB-M for CN851W1020 .

No.	Name	Code	Qty
1	Rear Cover Plate	01264704P	1
2	Rear Grill	01574102	1
3	Condenser Assy	0112416501	1
4	Left Side Plate Sub-Assy	01313256P	1
5	Streamlined Dome	26904112	2
6	Centrifugal Fan	10358202	2
7	Fan Motor	15704105	2
8	Motor Mounting Rack Sub-Assy	01324177P	2
9	Motor Mounting Rack	01324179P	4
10	Mounting Rack Sub-Assy3	01324175P	1
11	Mounting Rack Sub-Assy1	01324171P	1
12	Magnet Coil	4304000425	1
13	Electromagnetic Valve	43000054	1
14	4-way Valve	43000339	1
15	Magnet Coil	4300040030	1
16	4-way Valve Sub-Assy	04144164	1
17	Inhalation Tube Sub-Assy	04674168	1
18	Magnet Coil	4304000416	1

19	Electromagnetic Valve	43000054	1
20	Gas-liquid Separator	07424138	1
21	Liquid by-pass valve sub-assy1	07334324	1
22	Exit Tube Sub-Assy of Accumulator	04324776	1
23	Connection Pipe	05024954	1
24	Magnet Coil	4304000409	1
25	Electromagnetic Valve	43000054	
26	Electric expand valve fitting	4300010815	1
27	Electronic Expansion Valve	07130364	1
28	Electric Expansion Valve Sub-Assy	07334244	1
29	Accumulator	07424150	1
30	Suction Tube of Accumulator	04324753	1
31	Chassis Sub-assy	01194132P	1
32	Base Frame Sub-Assy	01284707	1
33	Compressor and fittings	00204124	1
34	Compressor and fittings	00204116	1
35	One way Valve	04324001	1
36	One way Valve	07130118	4
37	Magnet Coil	4304000411	1
38	Strainer Sub-Assy	07414132	1
39	Electromagnetic Valve	43044107	1
40	Fixed Mount3	01804181	1
41	Cut-off Valve	07138800	1
42	Cut-off Valve	07138799	1
43	Capillary Sub-Assy	04104153	1
44	Cut-off Valve	07130366	1
45	Electromagnetic Valve	43000054	1
46	Magnet Coil	4304000430	1
47	Support Crossbeam Sub-Assy	01324228P	1
48	Support Longitudinal	01894304P	1
49	Middle vertical prop sub-assy	01854111P	1
50	Mounting Rack Sub-Assy2	01324173P	1
51	Electric Box Assy	01394892	1
52	Electric Box Assy	01394789	1
53	Electric Box Cover	01264624P	1
54	Front Panel	0154461401P	1
55	Handle	26235253	4
56	Front Panel Sub-Assy	01544615P	1
57	Front Cover Plate	01264705P	1
58	Electric Box Cover2	01264170P	1
59	Strainer A	07210022	1
60	Cut-off Valve	07130239	1
61	Strainer A	07210022	1
62	low-pressure measure Sub-Assy	07384101	1
63	Oil Separator	07424186	1
64	connection Pipe Sub-Assy3	05025181	1
65	connection Pipe Sub-Assy2	05025182	1
66	connection Pipe Sub-Assy1	05025183	1
67	StrainerA	07210022	1

68	Capillary Sub-Assy	04104231	1
69	Right Side Plate	01313258P	1
70	One way Valve	07335210	1
71	Strainer A	07210022	1
72	Terminal Board	42011051	1
73	Wire Clamp	71010102	2
74	Overcurrent circuit breaker	45020214	1
75	Phase Reverse Protector	46020054	1
76	AC Contactor	44010245	1
77	Filter	43130016	1
78	AC Contactor	44010213	1
79	Main Board	30228606	1
80	Pinboard	30278301	1
81	Main Board	30220025	1
82	Terminal Board	42011103	4
83	Transformer	43110237	1
84	Electric Element Mounting Panel Sub-Assy 1	01324710	1
85	Reactor	43130174	1
86	Over Current Protector	46020112	1
87	Filter Board	30228111	1
88	Radiator	49010605	1
89	Main Board	30220025	1
90	Radiator	49018761	1
91	Magnet Coil	4300008302	1
92	Magnet Coil	4300008311	1
93	Magnet Coil	4300008312	1
94	Electromagnetic Valve	43000055	3
95	Pressure Protect Switch	46020009	3
96	Discharge Tube Sub-Assy	04634222	1
97	Sensor sub-assy	39008029G	1
98	Electrical heater	7651540701	1
99	Electrical heater	7651873202	1

● Exploded View of GMV-Pdm400W/NaB-M exploded views.

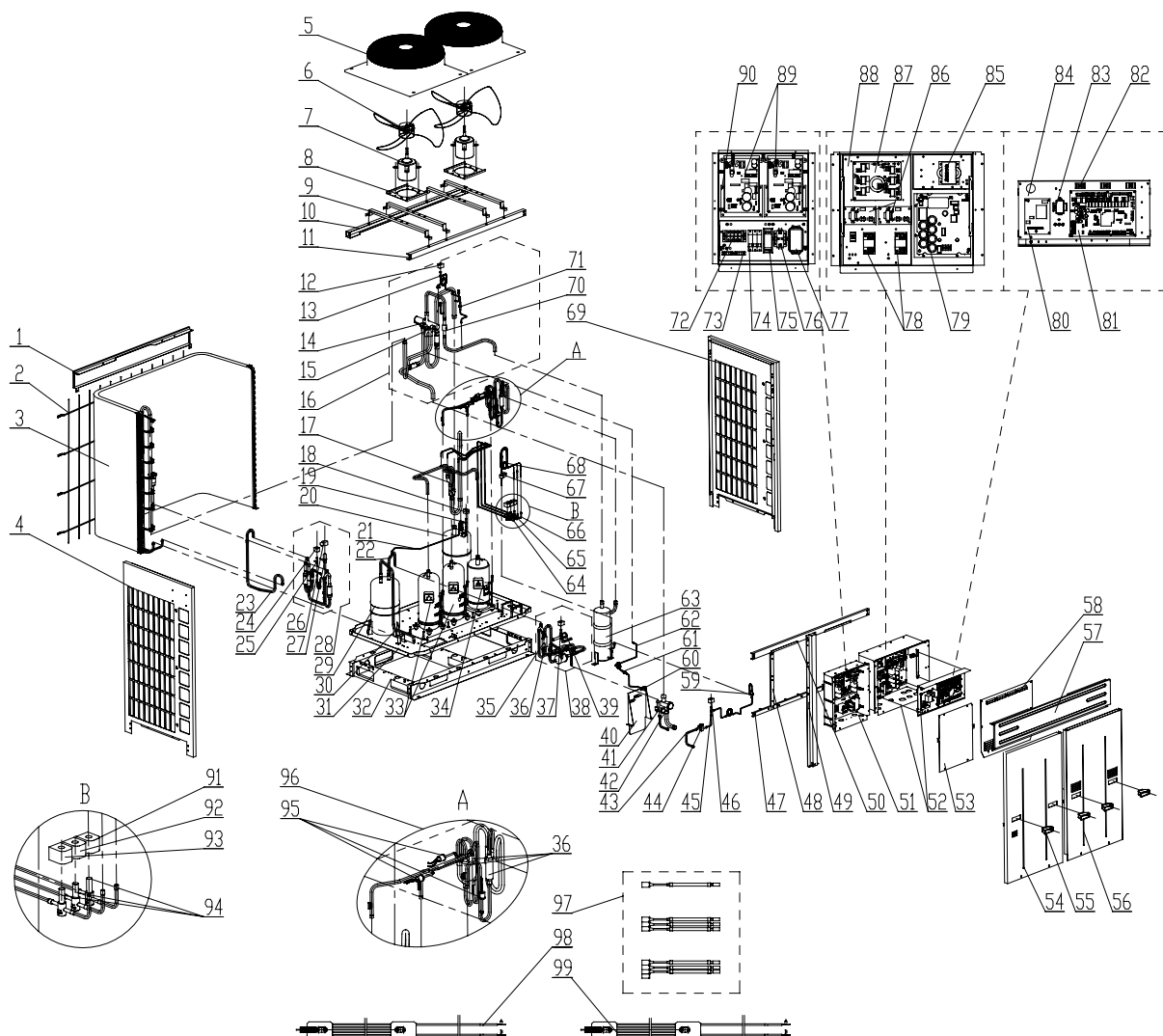

● Parts List of GMV-Pdm400W/NaB-M for CN851W1030 .

No.	Name	Code	Qty
1	Rear Cover Plate	01264704P	1
2	Rear Grill	01574102	1
3	Condenser Assy	0112416501	1
4	Left Side Plate Sub-Assy	01313256P	1
5	Streamlined Dome	26904112	2
6	Centrifugal Fan	10358202	2
7	Fan Motor	15704105	2
8	Motor Mounting Rack Sub-Assy	01324177P	2
9	Motor Mounting Rack	01324179P	4
10	Mounting Rack Sub-Assy3	01324175P	1
11	Mounting Rack Sub-Assy1	01324171P	1
12	Magnet Coil	4304000425	1
13	Electromagnetic Valve	43000054	1
14	4-way Valve	43000339	1
15	Magnet Coil	4300040030	1
16	4-way Valve Sub-Assy	04144164	1
17	Inhalation Tube Sub-Assy	04674168	1

18	Magnet Coil	4304000416	1
19	Electromagnetic Valve	43000054	1
20	Gas-liquid Separator	07424138	1
21	Liquid by-pass valve sub-assy1	07334324	1
22	Exit Tube Sub-Assy of Accumulator	04324776	1
23	Connection Pipe	05024954	1
24	Magnet Coil	4304000409	1
25	Electromagnetic Valve	43000054	
26	Electric expand valve fitting	4300010815	1
27	Electronic Expansion Valve	07130364	1
28	Electric Expansion Valve Sub-Assy	07334244	1
29	Accumulator	07424150	1
30	Suction Tube of Accumulator	04324753	1
31	Chassis Sub-assy	01194132P	1
32	Base Frame Sub-Assy	01284707	1
33	Compressor and fittings	00204117	1
34	Compressor and fittings	00204116	1
35	One way Valve	04324001	1
36	One way Valve	07130118	4
37	Magnet Coil	4304000411	1
38	Strainer Sub-Assy	07414132	1
39	Electromagnetic Valve	43044107	1
40	Fixed Mount3	01804181	1
41	Cut-off Valve	07138800	1
42	Cut-off Valve	07138799	1
43	Capillary Sub-Assy	04104153	1
44	Cut-off Valve	07130366	1
45	Electromagnetic Valve	43000054	1
46	Magnet Coil	4304000430	1
47	Support Crossbeam Sub-Assy	01324228P	1
48	Support Longitudinal	01894304P	1
49	Middle vertical prop sub-assy	01854111P	1
50	Mounting Rack Sub-Assy2	01324173P	1
51	Electric Box Assy	01394892	1
52	Electric Box Assy	01394789	1
53	Electric Box Cover	01264624P	1
54	Front Panel1	0154461401P	1
55	Handle	26235253	4
56	Front Panel Sub-Assy	01544615P	1
57	Front Cover Plate	01264705P	1
58	Electric Box Cover2	01264170P	1
59	Strainer A	07210022	1
60	Cut-off Valve	07130239	1
61	Strainer A	07210022	1
62	low-pressure measure Sub-Assy	07384101	1
63	Oil Separator	07424186	1
64	connection Pipe Sub-Assy3	05025181	1
65	connection Pipe Sub-Assy2	05025182	1
66	connection Pipe Sub-Assy1	05025183	1

67	StrainerA	07210022	1
68	Capillary Sub-Assy	04104231	1
69	Right Side Plate	01313258P	1
70	One way Valve	07335210	1
71	Strainer A	07210022	1
72	Terminal Board	42011051	1
73	Wire Clamp	71010102	2
74	Overcurrent circuit breaker	45020214	1
75	Phase Reverse Protector	46020054	1
76	AC Contactor	44010245	1
77	Filter	43130016	1
78	AC Contactor	44010213	1
79	Main Board	30228606	1
80	Pinboard	30278301	1
81	Main Board	30220025	1
82	Terminal Board	42011103	4
83	Transformer	43110237	1
84	Electric Element Mounting Panel Sub-Assy 1	01324710	1
85	Reactor	43130174	1
86	Over Current Protector	46020112	1
87	Filter Board	30228111	1
88	Radiator	49010605	1
89	Main Board	30220025	1
90	Radiator	49018761	1
91	Magnet Coil	4300008302	1
92	Magnet Coil	4300008311	1
93	Magnet Coil	4300008312	1
94	Electromagnetic Valve	43000055	3
95	Pressure Protect Switch	46020009	3
96	Discharge Tube Sub-Assy	04634222	1
97	Sensor sub-assy	39008029G	1
98	Electrical heater	7651540701	1
99	Electrical heater	7651873202	1



● Exploded View of GMV-Pdm450W/NaB-M exploded views.

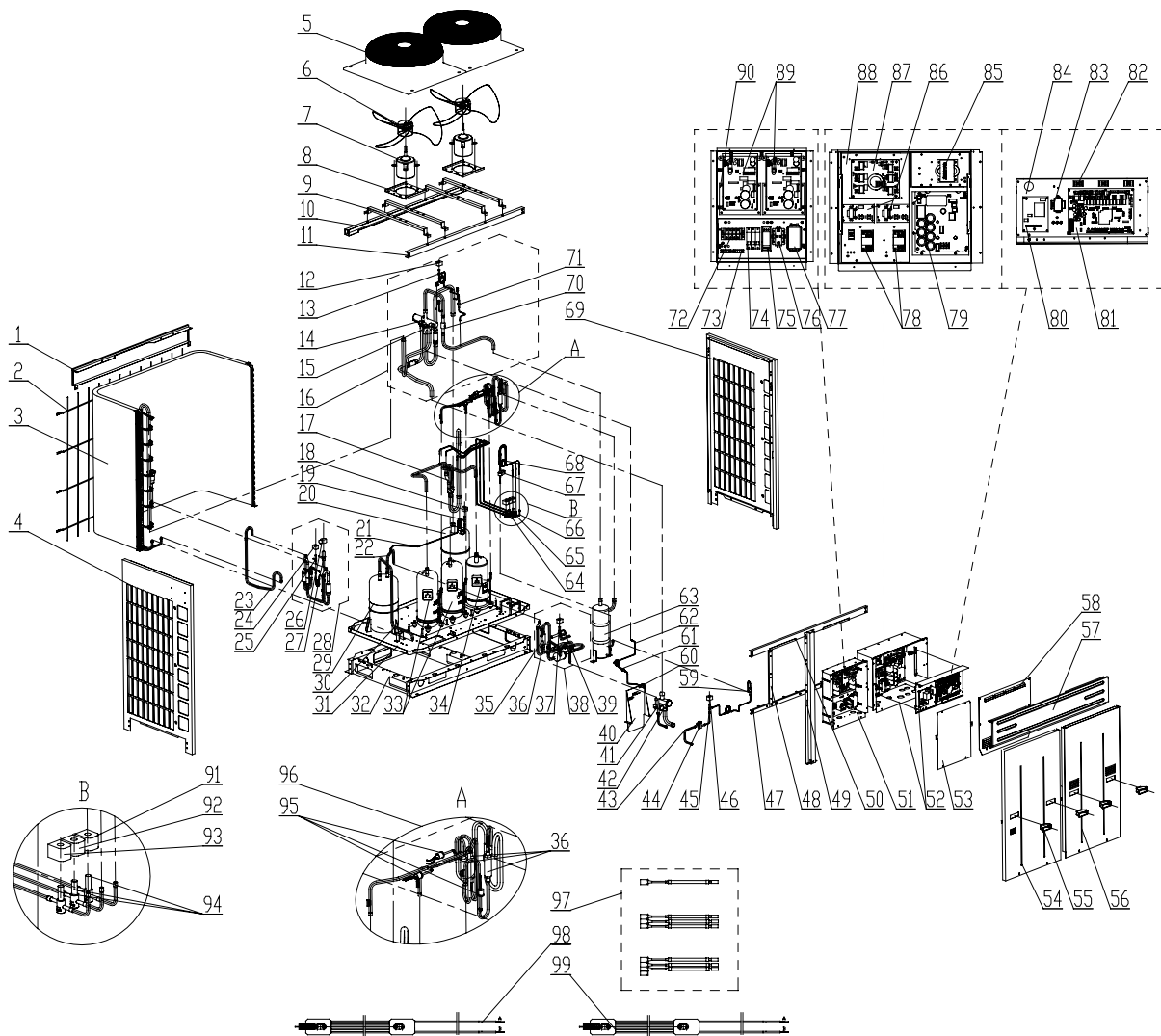

● Parts List of GMV-Pdm450W/NaB-M for CN851W1040.

No.	Name	Code	Qty
1	Rear Cover Plate	01264704P	1
2	Rear Grill	01574102	1
3	Condenser Assy	0112416501	1
4	Left Side Plate Sub-Assy	01313256P	1
5	Streamlined Dome	26904112	2
6	Centrifugal Fan	10358202	2
7	Fan Motor	15704105	2
8	Motor Mounting Rack Sub-Assy	01324177P	2
9	Motor Mounting Rack	01324179P	4
10	Mounting Rack Sub-Assy3	01324175P	1
11	Mounting Rack Sub-Assy1	01324171P	1
12	Magnet Coil	4304000425	1
13	Electromagnetic Valve	43000054	1
14	4-way Valve	43000339	1
15	Magnet Coil	4300040061	1
16	4-way Valve Sub-Assy	04144164	1
17	Inhalation Tube Sub-Assy	04674168	1

18	Magnet Coil	4304000416	1
19	Electromagnetic Valve	43000054	1
20	Gas-liquid Separator	07424138	1
21	Liquid by-pass valve sub-assy1	07334324	1
22	Exit Tube Sub-Assy of Accumulator	04324776	1
23	Connection Pipe	05024954	1
24	Magnet Coil	4304000409	1
25	Electromagnetic Valve	43000054	
26	Electric expand valve fitting	4300010815	1
27	Electronic Expansion Valve	07130364	1
28	Electric Expansion Valve Sub-Assy	07334244	1
29	Accumulator	07424150	1
30	Suction Tube of Accumulator	04324753	1
31	Chassis Sub-assy	01194132P	1
32	Base Frame Sub-Assy	01284707	1
33	Compressor and fittings	00204121	1
34	Compressor and fittings	00204116	1
35	One way Valve	04324001	1
36	One way Valve	07130118	4
37	Magnet Coil	4304000411	1
38	Strainer Sub-Assy	07414132	1
39	Electromagnetic Valve	43044107	1
40	Fixed Mount3	01804181	1
41	Cut-off Valve	07138800	1
42	Cut-off Valve	07138799	1
43	Capillary Sub-Assy	04104153	1
44	Cut-off Valve	07130366	1
45	Electromagnetic Valve	43000054	1
46	Magnet Coil	4304000430	1
47	Support Crossbeam Sub-Assy	01324228P	1
48	Support Longitudinal	01894304P	1
49	Middle vertical prop sub-assy	01854111P	1
50	Mounting Rack Sub-Assy2	01324173P	1
51	Electric Box Assy	01394892	1
52	Electric Box Assy	01394789	1
53	Electric Box Cover	01264624P	1
54	Front Panel1	01544116P	1
55	Handle	26235253	4
56	Front Panel Sub-Assy	01544604P	1
57	Front Cover Plate	01264705P	1
58	Electric Box Cover2	01264170P	1
59	Strainer A	07210022	1
60	Cut-off Valve	07130239	1
61	Strainer A	07210022	1
62	low-pressure measure Sub-Assy	07384101	1
63	Oil Separator	07424186	1
64	connection Pipe Sub-Assy3	05025181	1
65	connection Pipe Sub-Assy2	05025182	1
66	connection Pipe Sub-Assy1	05025183	1

67	StrainerA	07210022	1
68	Capillary Sub-Assy	04104231	1
69	Right Side Plate	01313258P	1
70	One way Valve	07335210	1
71	Strainer A	07210022	1
72	Terminal Board	42011051	1
73	Wire Clamp	71010102	2
74	Overcurrent circuit breaker	45020214	1
75	Phase Reverse Protector	46020054	1
76	AC Contactor	44010245	1
77	Filter	43130016	1
78	AC Contactor	44010213	1
79	Main Board	30228606	1
80	Pinboard	30278301	1
81	Main Board	30220025	1
82	Terminal Board	42011103	4
83	Transformer	43110237	1
84	Electric Element Mounting Panel Sub-Assy 1	01324710	1
85	Reactor	43130174	1
86	Over Current Protector	46020112	1
87	Filter Board	30228111	1
88	Radiator	49010605	1
89	Main Board	30220025	1
90	Radiator	49018761	1
91	Magnet Coil	4300008302	1
92	Magnet Coil	4300008311	1
93	Magnet Coil	4300008312	1
94	Electromagnetic Valve	43000055	3
95	Pressure Protect Switch	46020009	3
96	Discharge Tube Sub-Assy	04634222	1
97	Sensor sub-assy	39008029G	1
98	Electrical heater	7651540701	1
99	Electrical heater	7651873202	1





Add: West Jinji Rd, Qianshan, Zhuhai 519070, Guangdong, China

Tel: (+86-756) 8522218 Fax: (+86-756) 8669426

Email: [gree@gree.com.cn](mailto:gree@gree.com.cn)

<http://www.gree.com>

For continuous improvement in the products, Gree reserves the right to modify the product specification and appearance in this manual without notice and without incurring any obligations.

**JF00300207**