



Installation and Operation Manual

DC Inverter Floor Ceiling Type Air Conditioner (09K~60KBtu/h)

Indoor Unit	Outdoor Unit	Outdoor Unit
GTH09K3CI	GUHD09NK3CO	GUHD09NK3C1O
GTH12K3CI	GUHD12NK3CO	GUHD12NK3C1O
GTH18K3CI	GUHD18NK3CO	GUHD18NK3C1O
GTH24K3CI	GUHD24NK3CO	GUHD24NK3C1O
GTH30K3CI	GUHD30NK3CO	GUHD30NK3C1O
GTH36K3CI	GUHD36NK3CO	GUHD36NK3C1O
GTH42K3CI	GUHD42NK3CO	GUHD42NK3C1O
GTH48K3CI	GUHD48NK3CO	GUHD48NK3C1O
GTH36K3CI	GUHD36NM3CO	GUHD36NM3C1O
GTH42K3CI	GUHD42NM3CO	GUHD42NM3C1O
GTH48K3CI	GUHD48NM3CO	GUHD48NM3C1O
GTH60K3CI	GUHD60NM3CO	GUHD60NM3C1O

GREE ELECTRIC APPLIANCES, INC. OF ZHUHAI

Please read this manual carefully before using this product and keep it properly for future reference.

User Notice

- Ensure unified power supply for each indoor unit.
- Never install wired controller in wet place or under sunlight directly.
- Shielding twisted pair line must be adopted as signal line or wiring (communication) of wired controller once the unit is installed in the place where there is electromagnetic interference.
- Make sure communication line is connected into correct port to avoid communication malfunction.
- Never knock, throw or frequently disassemble the wired controller.
- Never operate the wired controller with wet hand.

Content

Safety Considerations	1
1. Displaying Part.....	3
1.1 LCD Display of Wired Controller	3
1.2 Instruction to LCD Display	4
2. Buttons	5
2.1 Silk Screen of Buttons	5
2.2 Instruction to Function of Buttons.....	5
3. Installation of Wired Controller	6
4. Instruction to Operation	7
4.1 On/Off.....	7
4.2 Mode Setting.....	7
4.3 Temperature Setting.....	8
4.4 Fan Speed Setting	8
4.5 Swing Control Function.....	9
4.6 Timer Setting	10
4.7 Air Exchange Setting *	12
4.8 Sleep Setting.....	13
4.9 Turbo Function Setting	15
4.10 SAVE Function Setting	16
4.11 E-HEATER Setting *	18
4.12 Blow Function Setting.....	19
4.13 Quiet Function Setting	21
5.14 Field Functions	22
4.15 Other Functions	23
5. Error Display.....	25
6. Remote Control Operation Procedure(standard fitting).....	28
6.1 Name and Function-Remote Control.....	28

6.2 Name and Function-Remote Control. (Remove the cover).....	29
6.3 COOL mode operation procedure.....	30
6.4 HEAT mode operation procedure.....	31
6.5 DRY mode operation procedure.....	32
6.6 AUTO mode operation procedure.....	33
6.7 FAN mode operation procedure.....	34
6.8 TIMER operation procedure.....	35
6.9 SLEEP mode operation procedure.....	36
6.10 How to insert batteries.....	37
7. Part Names and Their Functions.....	38
8. Maintenance.....	39
9. Operating Guide.....	40
10. Precautions.....	41
11. Checking Before Contact the Service Man.....	42
11.1 Accessories List for Installation.....	42
11.2 Installation of the Indoor Unit.....	44
11.3 Installation of the Outdoor Unit.....	47
11.4 Schematic Diagram of Unit Line Connection.....	49
11.5 Connecting Pipe Preparation.....	53
12. Appendix.....	59

Safety Considerations

Please read this manual carefully before use and operate correctly as instructed in the manual.

You are specially warned to note the two symbols below:



A symbol indicating that improper operation might cause human death or severe injury;



A symbol indicating that improper operation might cause human property damage.

This unit shall be used in offices, restaurants, residences or similar places.



WARNING!

- Please seek an authorized repair station for installation work. Improper installation might cause water leakage, electric shock or fire.
- Please install at a place strong enough to support the weight of air conditioner unit. Otherwise, the air conditioner unit might fall down and cause human injury or death.
- To ensure proper drainage, the drainage pipe should be correctly installed according to installation instructions. Take proper measures for heat preservation to prevent condensing. Improper installation of pipes might cause leakage and wet the articles in the room.
- Do not use or store flammable, explosive, poisonous or other dangerous substances beside the air conditioner.
- In case of troubles (e.g. burnt smell), please immediately cut off the main power of air conditioner unit.
- Keep air flow to avoid shortage of oxygen in the room.
- Never insert your finger or any objects into the air outlet or the inlet grill.
- Never plug or unplug the power cable directly to start or stop the air-conditioning unit.
- Please take constant care to check if the mounting rack is damaged after long time use.
- Never modify the air conditioner. Please contact the dealer or professional installation workers for repair or relocation of the air conditioner.
- The appliance should not be installed in the laundry.
- Before installation, please check the power supply for compliance with the ratings on nameplate. Check the power safety as well. (By professionals)
- Before use, please check and confirm if the cables, drainage pipes and pipelines are correctly connected, hence to eliminate the risk of water leakage, refrigerant leakage, electric shock or fire.
- Main power must be securely earthed to ensure effective grounding of the air conditioner unit and avoid the risk of electric shock. Please do not connect the earth cable to coal gas pipe, water pipe, lightning rod or telephone line.
- Once started, the air conditioner should not be stopped until at least five minutes later. Otherwise the oil return to the compressor may be affected.
- Do not let the child operate the air conditioner unit.
- Do not operate the air conditioner unit with wet hands.
- Please disconnect the main power before cleaning the air conditioner or replacing the air filter. (By professionals)
- Please disconnect the main power if the air conditioner is not to be used for a long period of time.
- Please do not expose the air conditioner unit directly in corrosive environment with water or moisture.
- Please do not foot on or place any goods on air conditioner unit.
- After electrical installation, the air conditioner unit should be energized for electrical leakage test. (By professionals)
- If the supply cord is damaged, it must be replaced by the manufacturer or its service agent or a similarly qualified person in order to avoid a hazard.

- An all-pole disconnection switch with a contact separation of at least 3mm in all poles should be connected with the fixed wiring.
- The appliance should be installed in accordance with national wiring regulations.
- Keep the interconnection cable away from the copper tube due to the high temperature of the refrigerant circuit.
- This appliance is not intended for use by persons (including children) with reduced physical, sensory or mental capabilities, or lack of experience and knowledge, unless they have been given supervision or instruction concerning use of the appliance by a person responsible for their safety.
- Children should be supervised to ensure that they do not play with the appliance.

1. Displaying Part



Fig.1 Outline of wired controller

1.1 LCD Display of Wired Controller

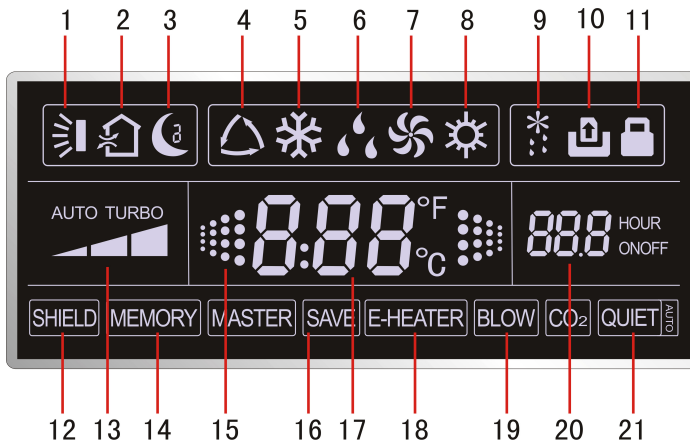

Fig.2 LCD display

1.2 Instruction to LCD Display

Table 1 Instruction to LCD Display

No.	Description	Instruction to Displaying Contents
1	Swing	Swing function
2	Air *	Air exchange function
3	Sleep	Sleeping states
4	Running mode	Each kind of running mode of indoor unit (auto mode)
5	Cooling	Cooling mode
6	Dry	Dry mode
7	Fan	Fan mode
8	Heating	Heating mode
9	Defrost	Defrosting state
10	Gate-control card *	Gate control
11	Lock	Lock state
12	Shield	Shielding state (buttons, temperature, on/off, mode or save is shielded by long-distance monitoring)
13	Turbo	Turbo function state
14	Memory	Memory state (Indoor unit resumes original setting state after power failure and then power recovery)
15	Twinkle	Flicking when unit is on without operation of buttons
16	Save	Energy-saving state
17	Temperature	Ambient/setting temperature value
18	E-Heater *	E-HEATER display means electric-heater is available
19	Blow	Blow mark
20	Timer	Timer-displayed location
21	Quiet	Quiet state(two types: quiet and auto quiet)
Notes: The functions with * are reserved for other models and are not applicable for the models listed in this manual.		

2. Buttons

2.1 Silk Screen of Buttons

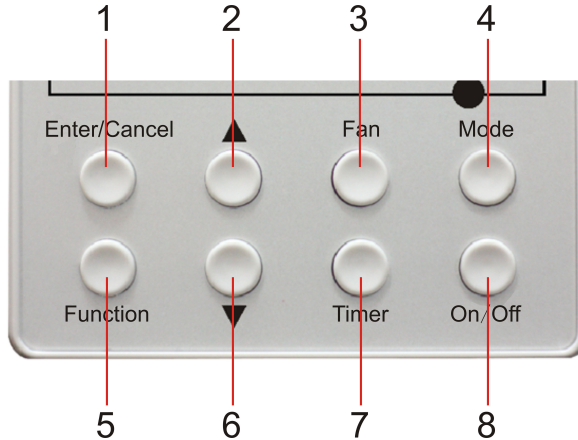

2.2 Instruction to Function of Buttons

Table 2 Instruction to Function of Buttons

No.	Description	Function of Button
1	Enter/Cancel	① Function selection and canceling; ② Press it for 5s to enquiry the outdoor ambient temperature.
2	▲	① Running temperature setting of indoor unit, range :16 ~ 30°C; ② Timer setting, range:0.5-24hr; ③ Switchover between quiet/auto quiet .
6	▼	
3	Fan	Setting of high/middle/low/auto fan speed.
4	Mode	Setting of cooling/heating/fan/dry mode of indoor unit.
5	Function	Switchover among these functions of air/sleep/turbo/save/e-heater/blow/quite.
7	Timer	Timer setting.
8	On/off	Turn on/off indoor unit.
4 Mode and 2 ▲	Memory function	Press Mode and ▲ for 5s under off state of the unit to Enter/Cancel key memory function (If memory is set, indoor unit will resume original setting state after power failure and then power recovery. If not, indoor unit is defaulted to be off after power recovery. Memory function is defaulted to be set before outgoing).
2 ▲ and 6 ▼	Lock	Upon startup of the unit without malfunction or under off state of the unit, press ▲ ▼ key at the same time for 5s in to lock state. In this case, any other buttons won't respond the press. Repress ▲ ▼ key for 5s to quit lock state.

3. Installation of Wired Controller

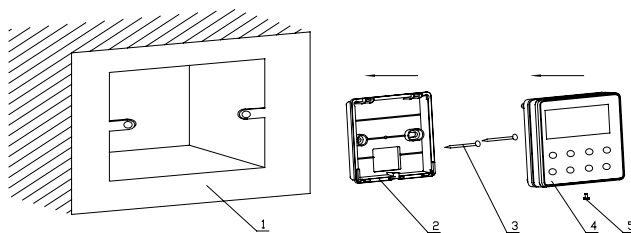

Fig.4 Sketch for Installation of Wired Controller

No.	1	2	3	4	5
Description	Socket's base box installed in the wall	Soleplate of controller	Screw M4X25	Front panel of controller	Screw ST2.2X6.5

Fig.4: Sketch for Installation of Wired Controller. Pay attention to the following items during installation of wired controller:

1. Cut off power supply of heavy-current wire embedded in mounting hole in the wall before installation. It is prohibited to perform the whole procedure with electricity.
2. Pull out 4-core twisted pair line in mounting hole and then make it through the rectangle hole at the back of controller's soleplate.
3. Joint the controller's soleplate on wall face and then fix it in mounting hole with screws M4X25.
4. Insert the 4-core twisted pair line through rectangle hole into controller's slot and buckle the front panel and soleplate of controller together.
5. At last, fix the controller's front panel and soleplate with screws ST2.2X6.5.

Caution:

During connection of wirings, pay special attention to the following items to avoid interference of electromagnetism to unit and even failure of it.

1. To ensure normal communication of the unit, signal line and wiring (communication) of wired controller should be separate from power cord and indoor/outdoor connection lines. The distance between them should be kept 20cm in min.
2. If the unit is installed at the place where there is interference of electromagnetism, signal line and wiring (communication) of wired controller must be shielded by twisted pair lines.

4. Instruction to Operation

4.1 On/Off

Press **On/Off** button to turn on the unit.

Repress this button to turn off the unit.

Note: The state shown in Fig.5 indicates off-state of the unit after energization.

The state shown in Fig.6 indicates on-state of the unit after energization.



Fig.5 Off state of the unit



Fig.6 On state of the unit

4.2 Mode Setting

Under on-state of the unit, press **Mode** button to switch the operation modes as the following sequence:

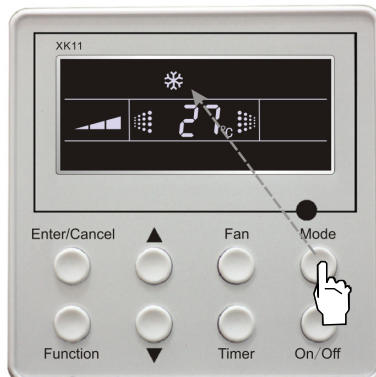

4.3 Temperature Setting

Press ▲ or ▼ button to increase or decrease of setting temperature under on-state of the unit. If press either of them continuously, temperature will be increased or decreased by 1°C every 0.5s.

In Cooling, Dry, Fan and Heating mode, temperature setting range is 16°C~30°C.

In Auto mode, the setting temperature is un-adjustable.

As shown in Fig.7.

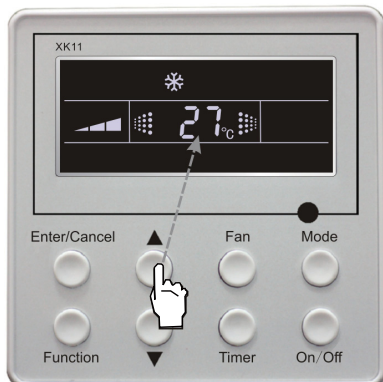

Fig 7

4.4 Fan Speed Setting

Press **Fan** button, fan speed of indoor unit will change as below:

As shown in Fig.8

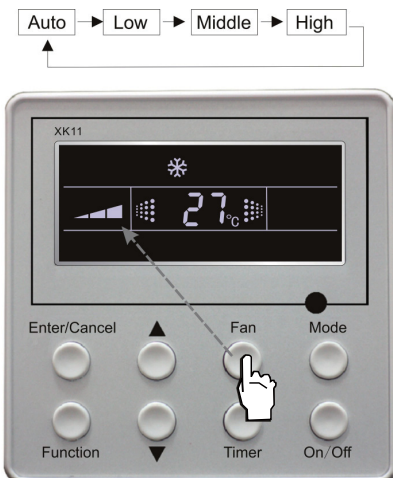

Fig.8

4.5 Swing Control Function

Under on-state of unit, press **Function** button till the unit enters swing control function and then press Enter/Cancel button to turn on “swing” control function.

During swing function, press **Function** button till the unit enters swing control function and then press **Enter/Cancel** button to cancel swing control function.

Swing control function setting is shown in Fig.9 :

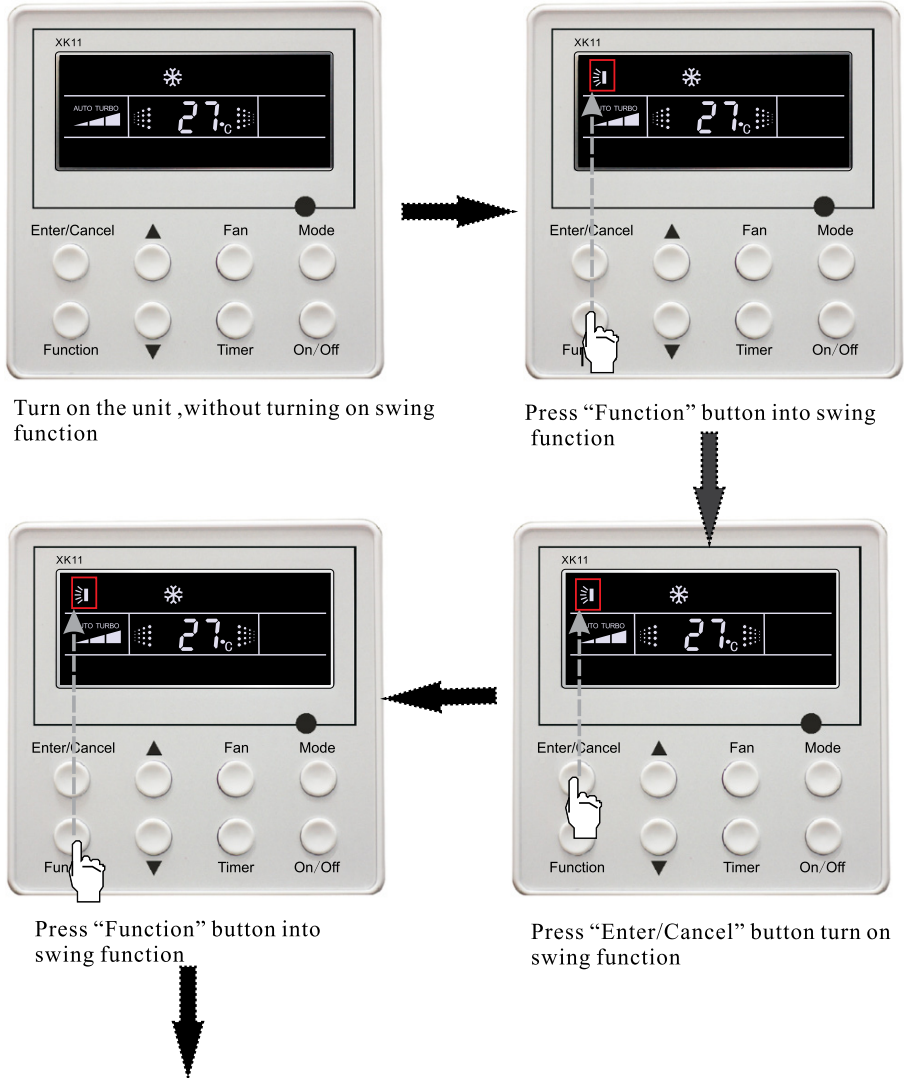

(continued)



Press “Enter/Cancel” button
turn on swing function

Fig.9 Swing control function setting

4.6 Timer Setting

Press **Timer** to set timer off of the unit. Under off-state of the unit, press Timer button to set timer on of the unit in the same way.

Timer on setting: Under off-state of the unit without timer setting, if **Timer** button is pressed, LCD will display **xx. Hour**, with **ON** blinking. In this case, press **▲** or **▼** button to adjust timer on and then press **Timer** to confirm. If **Mode** button is pressed before pressing **Timer** button to confirm, timer mode will be switched to timer off setting mode. In this case, LCD displays **xx. Hour**, with **OFF** blinking. In this case, press **▲** or **▼** button to adjust timer off and then press **Timer** to confirm. When LCD displays:“**xx. Hour on off**”; **xx. Hour** means time of timer on, but time of timer off won’t be displayed.

Timer off setting: Under **on-state** of the unit without timer setting, if **Timer** button is pressed, LCD will display **xx. Hour**, with **OFF** blinking. In this case, press **▲** or **▼** button to adjust timer on and then press **Timer** to confirm. If **Mode** button is pressed before pressing **Timer** button to confirm, timer mode will be switched to timer on setting mode. In this case, LCD displays **xx. Hour**, with **ON** blinking. In this case, press **▲** or **▼** button to adjust timer on and then press **Timer** button to confirm. When LCD displays **xx. Hour On Off**, **xx. Hour** means time of timer off, but time of timer on won’t be displayed.

Cancel timer: After setting of timer, if **Timer** button is pressed, LCD won’t display **xx. Hour** so that timer setting is canceled.

Timer off setting under **on-state** of the unit is shown as Fig.10:



Turn on the unit, without setting timer



Press "Timer" button to set



Press "Mode" switch to time on setting

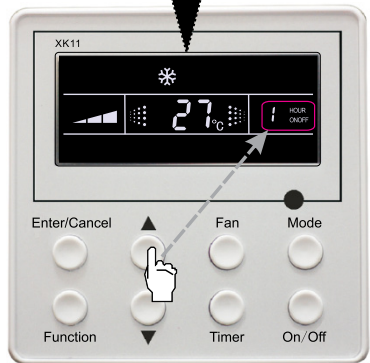

Press "▲" or "▼" button to adjust time

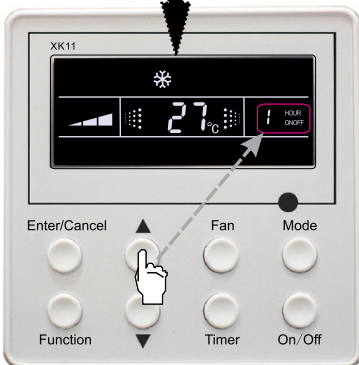

Press "▲" or "▼" button to adjust time



Press "Timer" to confirm timer setting

Fig.10 Timer setting under on state of the unit

Timer range: 0.5-24hr. Every press of ▲ or ▼ button will make setting time increased or decreased by 0.5hr.If press either of them continuously, setting time will automatically increase/ decrease by 0.5hr every 0.5s.

Note:

1. If both timer on and timer off are set in unit on interface, the wired controller only display time of time off. If both of them are set in unit off-state, only time of timer on is displayed.

2. Timer on in unit on-state is timed from the time of unit off and timer off in unit off-state is timed from the time of unit on.

4.7 Air Exchange Setting *

Turn on air Exchange function:

Under on-state of the unit, press Function button to go to this function setting (Air mark blinks).AIR 1 displayed at the ambient temperature-displayed location (888) is defaulted (the last type of AIR will be displayed after adjustment).Press ▲ or ▼ button to adjust air type. Press Enter/Cancel button to turn on/off air function. After turning on this function, the air mark shows.

There are 10 types of AIR, but only 1-2 types are for remote control. Refer to the following details:

- 1—The unit continuously runs for 60min, and fresh air valve runs for 6 min.
- 2—The unit continuously runs for 60min, and fresh air valve runs for 12 min.
- 3—The unit continuously runs for 60min, and fresh air valve runs for 18 min.
- 4—The unit continuously runs for 60min, and fresh air valve runs for 24 min.
- 5—The unit continuously runs for 60min, and fresh air valve runs for 30 min.
- 6—The unit continuously runs for 60min, and fresh air valve runs for 36 min.
- 7—The unit continuously runs for 60min, and fresh air valve runs for 42 min.
- 8—The unit continuously runs for 60min, and fresh air valve runs for 48 min.
- 9—The unit continuously runs for 60min, and fresh air valve runs for 54 min.
- 10—The unit continuously runs for 60min, and fresh air valve always runs.

Turn off air Exchange function: During Air function, press Function button to go to the Air function. In this case, air mark is blinking, and then press Enter/Cancel button to turn off this function. Air mark will subsequently disappear.

Air Exchange setting is shown as in Fig.11:

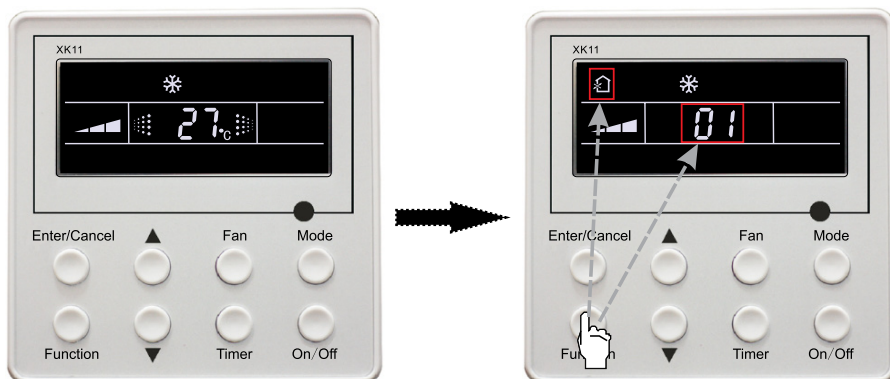

Turn on the unit,without turning on AIR Exchange

Press“Function”button into AIR Exchange

(continued)

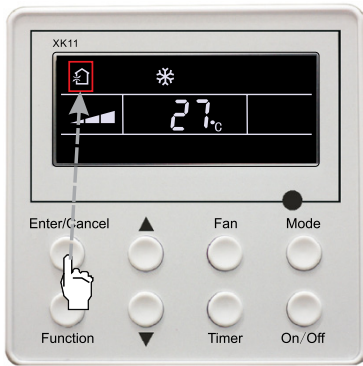

Press "Enter/Cancel" button to turn on AIR Exchange

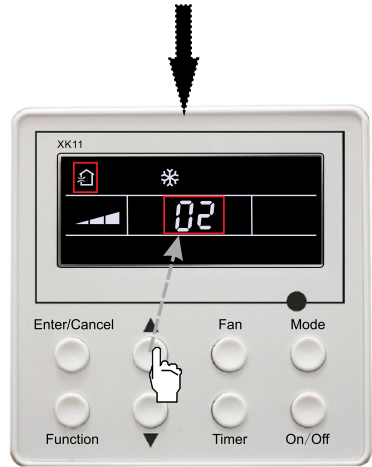

Press "▲" or "▼" button to adjust the type of AIR Exchange

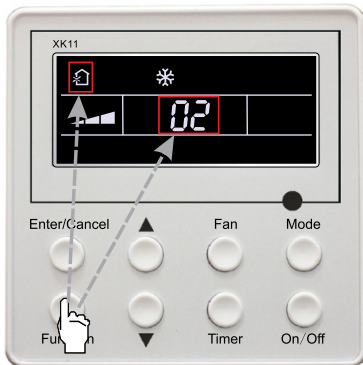

Press "Function" button into AIR Exchange

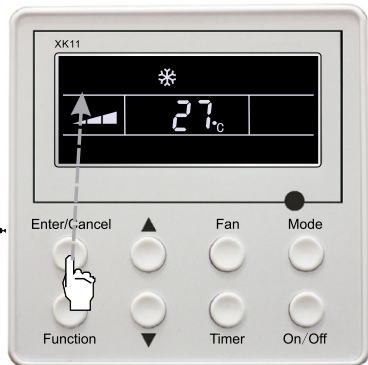

Press "Enter/Cancel" button to turn off AIR Exchange

Fig.11 Air exchange device

Note: In air exchange mode, press Function button or there is not any operation within 5s after the last button operation, the system will be quit from air exchange setting and current energy-saving data won't be memorized.

4.8 Sleep Setting

Sleep on: Press **Function** button under on-state of the unit into sleep function and then press **Enter/Cancel** button to turn on sleeping function.

Sleep off: During sleep on-state, press **Function** button to go to the sleep function and then press **Enter/Cancel** button to turn off this function.

Sleep setting is shown as Fig.12:



Turn on the unit ,without turning on sleep function

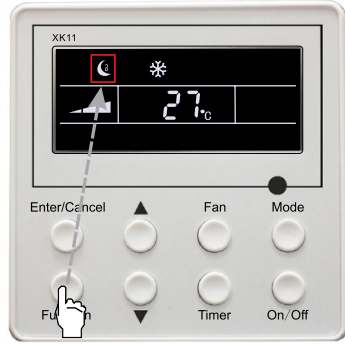

Press“Function”button into sleep function

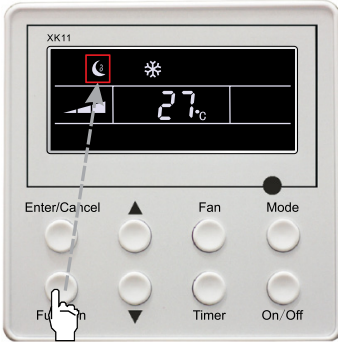

Press“Enter /Cancel” button to turn on sleep function

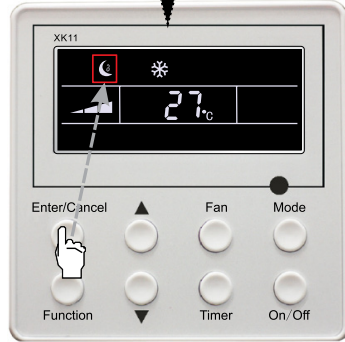

Press“Function”button into sleep function



Press“Enter /Cancel” button to turn off sleep function

Fig.12 Sleep setting

Sleep setting is clear after power failure and then power recovery. There is not sleep function in fan and auto mode.

Note:

In cooling and dry mode, if the unit with sleep function has run for 1 hour, the preset temperature will be increased by 1°C and 1°C in another 1 hour. After that, the unit will run at this temperature. In heating mode, if the unit with sleep function has run for 1 hour, the preset temperature will be decreased by 1°C and 1°C in another 1 hour. After that, the unit will run at this temperature.

4.9 Turbo Function Setting

TURBO function: The unit at high fan speed can realize quick cooling or heating so that room temperature can quickly approach setting temperature.

In cooling or heating mode, press **Function** button till the unit enters **TURBO** function and then press **Enter/Cancel** button to turn on **TURBO** function.

During **TURBO** function, press **Function** button till the unit enters **TURBO** function and then press **Enter/Cancel** button to cancel **TURBO** function.

TURBO function setting is shown in Fig.13:

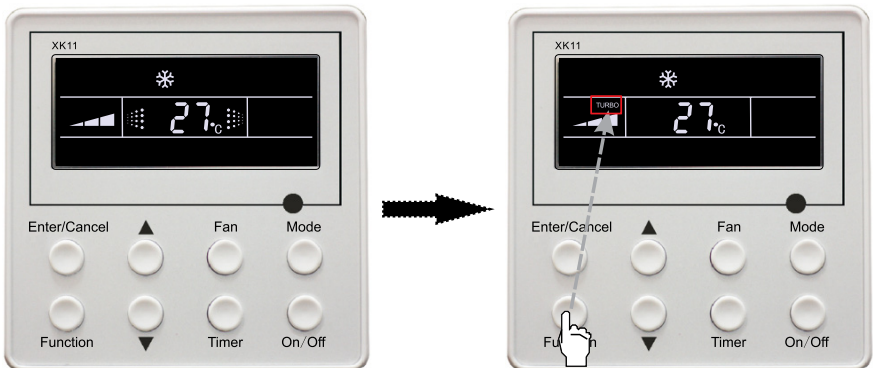

Turn on the unit, without turning on Turbo function

Press“Function”button into turbo function

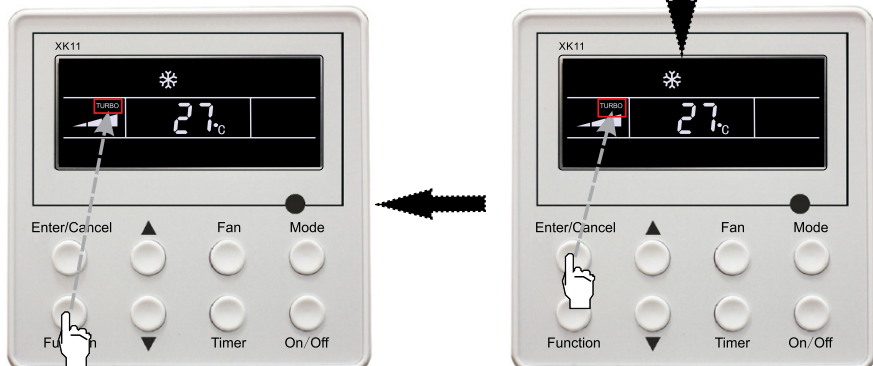

Press“Function”button into turbo function

Press“Enter /Cancel” button to turn on turbo function

(continued)

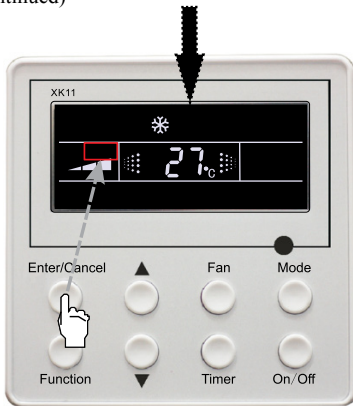

Press“Enter /Cancel” button to turn off turbo function

Fig.13 Turbo Function Setting

Note:

1. **TURBO** function will be turned off after power failure and then recovery. In dry, fan and auto mode, **TURBO** function can not be set and **TURBO** mark won't be displayed.
2. **TURBO** function will be automatically canceled after setting of quiet function.

4.10 SAVE Function Setting

Energy Saving Function: Energy saving can make the air conditioner runs in a smaller temperature range by setting lower limited value of setting temperature in cooling or dry mode and upper limited value in heating mode.

Energy Saving Setting for Cooling

Under on-state and in cooling or dry mode of the unit, press **Function** button into energy saving function, with **SAVE** blinking .Press **▲** or **▼** button to adjust lower limited value of setting temperature in cooling mode. After that press **Enter/Cancel** button to turn on energy saving function for cooling.

Energy Saving Setting for Heating

Under on state and in heating mode of the unit, press **Function** button into energy saving function, with **SAVE** blinking. Press **Mode** button into energy saving function for heating and then press **▲** or **▼** button to adjust upper limited value of setting temperature in heating mode. After that, press **Enter/Cancel** button to turn on energy saving function for heating.

After energy saving function is turned on, press **Function** button into energy saving function and press **Enter/Cancel** to cancel this function.

The energy saving setting is shown in the Fig.14:



Turn on the unit ,without turning on save function

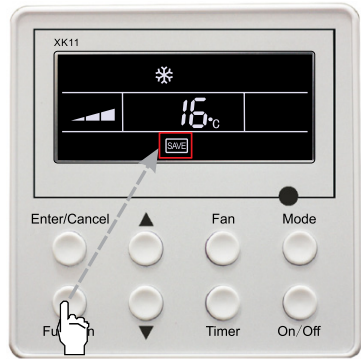

Press“Function”button into cooling save function

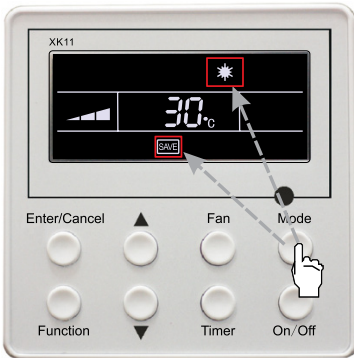

Press“Mode”button switch to heating save function

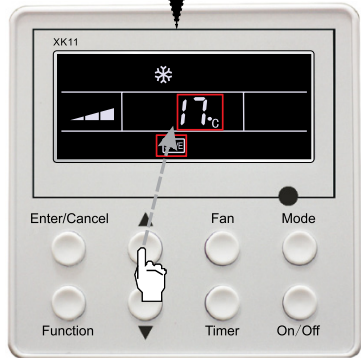

Press“▲” or “▼” button to change the lower limit of cooling

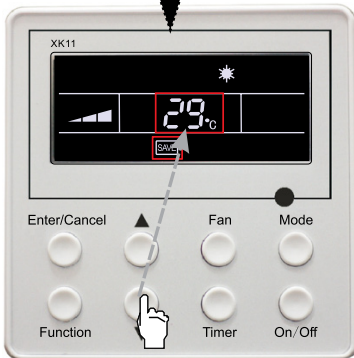

Press “▲” or “▼” button to change the upper limit of heating

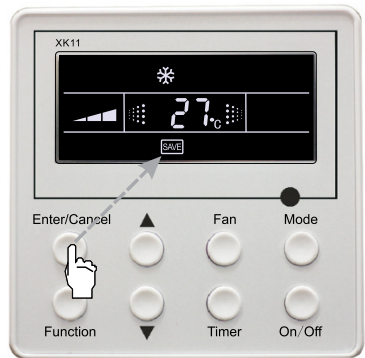

Press“Function”button to turn on air function

Fig.14 Energy Saving Setting

Note:

1. In Auto running mode with save function on, the unit will be forcibly quit Auto running Mode and change to current operation mode, After setting of save, sleep function will be canceled.
2. In save mode, if **Function** button is pressed or there is not any operation within 5s after the last button operation, the system will be quit from save function setting and current data won't be memorized.
3. After power failure and then recovery, save function setting will be memorized.
4. The lower limited value in cooling mode is 16°C and the upper limited value in heating mode is 30°C.
5. After save setting, if the setting temperature is out of the range in the mode, the limited value will prevail.

4.11 E-HEATER Setting *

E-HEATER: In the heating mode, E-heater is allowed to be turned on for improvement of efficiency. If heating mode is turned on by button operation, auxiliary electric heating function will be automatically turned on.

Press **Function** button in heating mode to go to the auxiliary electric heating function, the **E-HEATER** blinking, and press **Enter/Cancel** button to turn on this function. In this case, the **E-HEATER** will be displayed, which means E-heater is allowed to be turned on.

If auxiliary electric heating function is on, press **Function** button to confirm or press **Enter/Cancel** button to cancel. In this case, **E-HEATER** won't be displayed, which means E-heater is prohibited to be turned on. The setting of this function is shown as Fig.15 below:

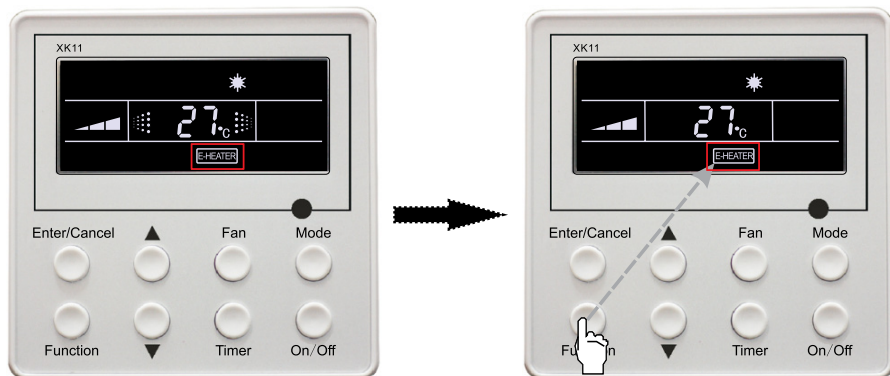

Auxiliary electric heating function will be automatically turn on under heating mode

Press“Function”button into E-Heater function

(continued)

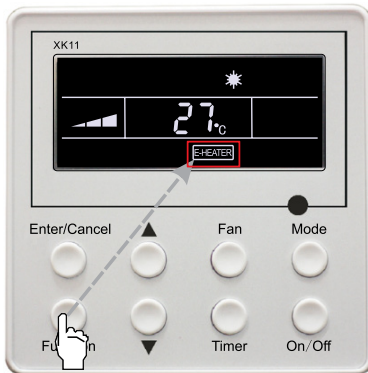

Press“Function”button into E-Heater function

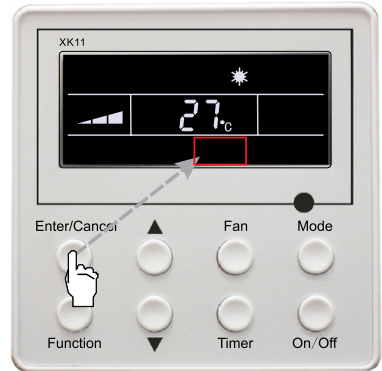

Press“Enter /Cancel” button to turn off E-Heater function

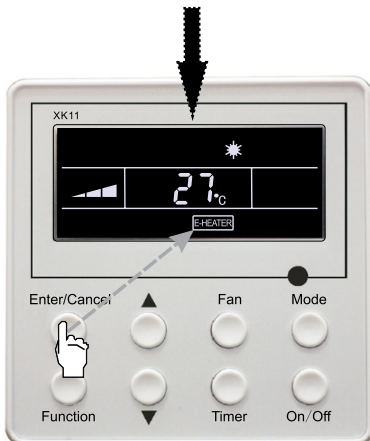

Press“Enter /Cancel” button to turn on E-Heater function

Fig.15 Auxiliary Electric Heating Function Setting

Note:

E-HEATER can not be set in cooling, dry and fan mode, **E-HEATER** mark won't be displayed. The setting is shown in Fig.15.

4.12 Blow Function Setting

BLOW function: After the unit is turned off, water in evaporator of indoor unit will be automatically evaporated to avoid mildew.

In cooling and dry mode, press Function button till the unit enters BLOW function, with BLOW blinking, and then press **Enter/Cancel** button to turn on this function.

In BLOW mode, press Function button till the unit enters BLOW function and then press **Enter/Cancel** button to cancel this function.

BLOW function setting is shown in Fig.16:



Turn on the unit, without turning on blow function

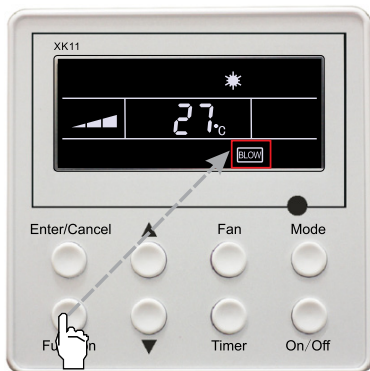

Press "Function" button into blow function

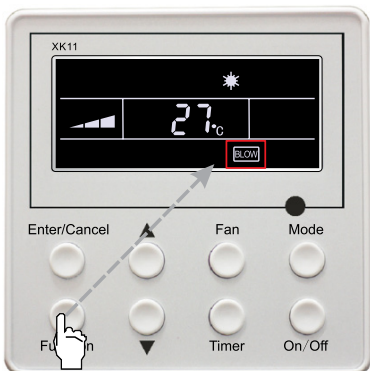

Press "Function" button into blow function

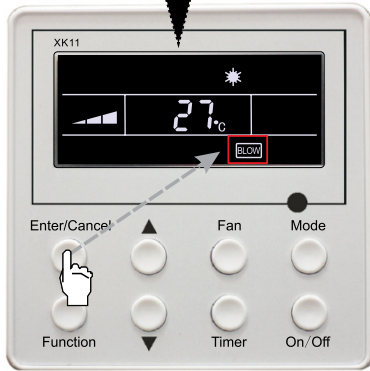

Press "Enter /Cancel" button to turn on blow function

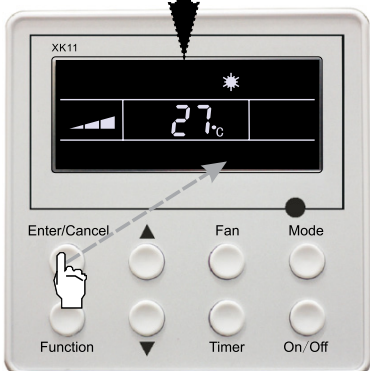

Press "Enter /Cancel" button to turn off blow function

Fig.16 Blow function setting

Note:

1. After setting BLOW function, turn off the unit by pressing On/Off button on remote controller, indoor fan will run at low fan speed for 10 min. (BLOW shows). Meanwhile, if BLOW function is canceled indoor fan will be turned off directly.

2. There is not BLOW function in fan or heating mode.

4.13 Quiet Function Setting

Quiet function consists of two kinds: QUIET and AUTO QUIET.

Press Function button till the unit enters quiet function setting state, Quiet or Auto Quiet mark blinks. In this case, press ▲ or ▼ button to switch between Quiet and Auto Quiet and then press **Enter/Cancel** button to turn on this function.

In quiet mode, press Function button till the unit enters quiet function. In this case, Quiet or Auto Quiet icon blinks and then press **Enter/Cancel** button to cancel this function.

Quiet function setting is shown in Fig.17

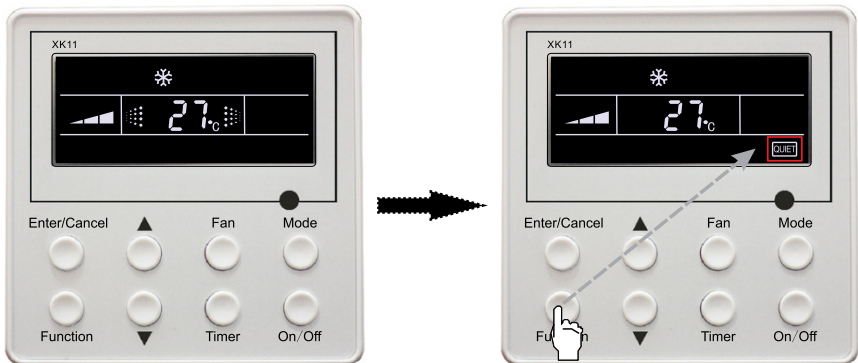

Turn on the unit, without turning on quiet function

Press "Function" button into quiet function

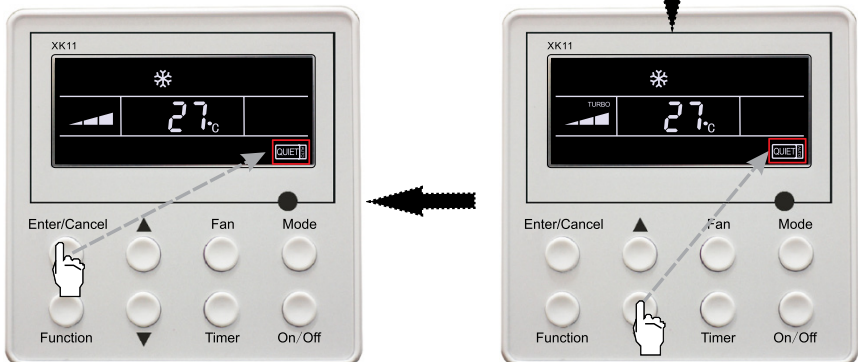

Press "▲" or "▼" button switch to auto quiet function

Press "Function" button to turn on the type of quiet function

(continued)

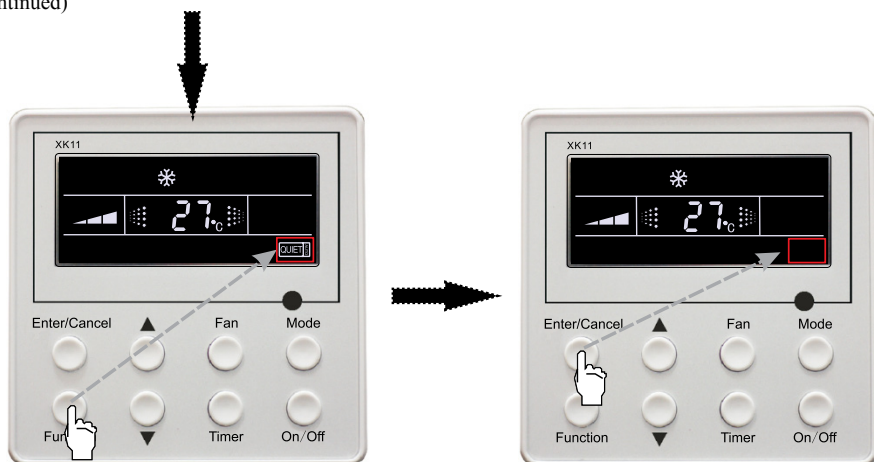

Press“Function”button into quiet function

Press“Enter /Cancel” button to turn off quiet function

Fig.17 Quiet function setting

Note:

1. During quiet function, fan speed is un-adjustable.
2. When turning on auto quiet function, the unit will enter quiet running state according to temperature difference between room temperature and setting temperature. In this case, fan speed is adjustable. If temperature difference between room temperature and setting temperature $\geq 4^{\circ}\text{C}$, fan will keep its current speed; if $2^{\circ}\text{C} \leq \text{temperature difference} \leq 3^{\circ}\text{C}$; fan speed will be reduced by one grade ,but if it is at minimum grade, it is un-adjustable.; if temperature difference $\leq 1^{\circ}\text{C}$, fan speed will be at minimum grade
3. In auto quiet mode, fan speed can not be raised but reduced. If high fan speed is manually adjusted, auto quiet mode will quit.
4. There is not auto quiet function in fan or dry mode. Quiet off is default after power failure and then power recovery.
5. If quite function is set, turbo function will be canceled.

5.14 Field Functions

Under off-state of the unit, press **Function** and **Timer** buttons continuously for 5s to go to the debugging menu. Press Mode button to adjust the setting items and \blacktriangle or \blacktriangledown button to set the actual value.

5.14.1 Ambient Temperature Sensor Setting

In field setting mode, press **Mode** button to adjust the temperature displayed location displaying 00, and press \blacktriangle or \blacktriangledown button to adjust setting state at timer displayed location. There are 3 types for selection:

- Indoor ambient temperature is that at return air inlet (01 is displayed at timer displayed location)
- Indoor ambient temperature is that at the place of screen (02 is displayed at timer displayed location)
- Return air inlet temperature sensor shall be selected for cooling, dry and fan modes and wired controller temperature sensor (03 is displayed at timer displayed location) shall be selected for heating and auto modes.

5.14.2 Three Grades of Speed for Indoor Fan

In field setting mode, press Mode button to adjust the temperature displayed location displaying 01 and press ▲ or ▼ button to adjust setting state at timer displayed location. There are 2 types for selection:

- 3 low grades (LCD displays 01)
- 3 high grades (LCD displays 02)

Three low grades indicate high, medium and low grades and 3 high grades indicate super-high, high and medium grades.

Press **Enter/Cancel** button to save the setting and quit after setting. If there is not any operation within 20s after the system responds to the last button operation in this interface, the system will quit this menu and display normal off-state; meanwhile, current setting won't be saved.

4.15 Other Functions

4.15.1 Lock Function

Upon startup of the unit without malfunction or under off-state of the unit, press ▲ and ▼ buttons at the same time for 5s till the wired controller enters lock state. In this case, LCD displays: . After that, repress these two buttons at the same time for 5s to quit lock state.

Under lock state, any other buttons won't give any response to the press.

4.15.2 Memory Function

Memory switchover: Under off-state of the unit, press Mode and ▲ buttons at the same time for 5s to switch memory modes. During setting memory mode, Memory will be displayed. If this function is not set, the unit will be under off state after power failure and then power recovery.

Memory recovery: If memory mode has been set for wired controller, the wired controller after power failure will resume its original running state upon power recovery.

Note: It will take about 5 seconds to save all the information, therefore, please do not cut down the power at this time, or it may fails.

4.15.3 Enquiry of Outdoor Ambient Temperature

Under on or off state of the unit, press **Enter/Cancel** button for 5s, outdoor ambient temperature will be displayed at temperature displaying location after a sound of click. This enquiry state will quit by pressing any button. If there is not any operation for 20s, it will automatically quit.

Note:

1. This function will be shielded after energization of 12hr for some models of the units without outdoor ambient sensors. Please refer to Instruction for details.
2. If malfunction of outdoor ambient sensor occurs, this function will be shielded in 12hr.

4.15.4 Selection of Centigrade and Fahrenheit

Under off state of the unit, press Mode and ▼ at the same time for 5s, the displayer panel will switch between Centigrade and Fahrenheit.

4.15.5 Master/Slave Wired Controller Setting

Under the off status of the unit, press “**Enter/Cancel**” and “Mode” at the same time for 5 seconds to go to the master/slave wired controller setting interface, and then press ▲ or ▼ to make the adjustment. In this case, only in the temperature display is there numbers displayed, 01 for the master wired controller and 02 for the slave wired controller.

After that, press “**Enter/Cancel**” to save the setting and quit this interface. If there is not any operation

in 20 seconds on this interface after the last button press, the system will quit automatically to the normal off status without saving the current setting.

Note: If there is only one wired controller, it only can be set as the master; otherwise the unit won't run normally.

5. Error Display

If there is malfunction during running of the system, LCD will display error code at temperature–displayed location. Once there is more than one malfunction, error codes will be displayed circularly. If there are multiple circuit systems, the system number of failed system will be displayed before the colon (not for single system).

If malfunction occurs, turn off the unit and contact nearest dealer for help.

As shown in Fig.18, it means high pressure protection of system 2 under unit on.



Fig.18

Error code meaning:

Error code	Malfunction
E0	Water Pump Malfunction
E1	High pressure protection of compressor
E2	Indoor anti-freezing protection
E3	Low pressure protection of compressor
E4	High discharge temperature protection of compressor
E5	Compressor overload or drive error
E6	Communication malfunction
E9	Water overflow protection
F0	Indoor unit ambient sensor malfunction at air return opening
F1	Evaporator sensor malfunction
F2	Condenser sensor malfunction
F3	Outdoor unit ambient temperature sensor malfunction
F4	Discharge temperature sensor malfunction
F5	Ambient sensor malfunction on Displayer (or LED board)

DC Inverter Floor Ceiling Type Air Conditioner

The LED Indicator Display on the Main Board of Outdoor Unit (12K)

This table is applicable to the electric control box of the 12K C Series DC inverter air conditioners. Some of the items are not malfunction; they mean the normal running status.

Running Status	Outdoor unit Yellow Lamp	Outdoor unit Red Lamp	Outdoor unit Green Lamp	wired controller Display
Compressor started	Flash once			
Defrosting	Flash twice			Displayed
Anti-freezing protection	Flash 3 times			E2
IPM protection	Flash 4 times			E5
Over-current protection	Flash 5 times			E5
Heat exchanger overload protection	Flash 6 times			/
Discharge protection	Flash 7 times			E4
Compressor overload protection	Flash 8 times			E5
Power protection	Flash 9 times			E5
Module overheating protection	Flash 10times			E5
EEPROM reading error	Flash 11 times			E5
Low voltage protection	Flash 12times			E5
High voltage protection	Flash 13times			E5
PFC over-current protection	Flash 14times			E5
Unmatched indoor and outdoor units	Flash 16times			/
Limited frequency(current)		Flash once		/
Limited frequency (discharge)		Flash twice		/
Limited frequency (overload)		Flash 3 times		/
Reduced frequency (anti-freezing)		Flash 4 times		/
Outdoor ambient temperature sensor error		Flash 6 times		F3
Outdoor pipe temperature sensor error		Flash 5 times		F2
Outdoor discharge temperature sensor error		Flash 7 times		F4
Up to the startup temperature		Flash 8 times		/
Limited frequency(module temperature)		Flash 11times		/
Limited frequency (power)		Flash 13times		/
Communication normal			Flash continuously	/
Communication error			Black out	E6
Indoor ambient temperature sensor error				F0
Indoor pipe temperature sensor error				F1

Definition of Malfunction Codes of DC Inverter General Outdoor Unit (V1.6)

This table is applicable to the electric control box of the other models of C-Series DC inverter air conditioners.

Malfunction Item	Outdoor unit display of dual 8 numeral tube	Indoor Unit Display
DC busbar over voltage protection	PH	E5
Overheat protection of radiator	P8	E5
Current sensor malfunction	Pc	E5
Radiator sensor malfunction	P7	E5
Compressor current protection	P5	E5
DC busbar under voltage protection	PL	E5
Compressor startup failure	Lc	E5
PFC abnormality	Hc	E5
Drive resetting	P0	E5
The compressor motor in loss of synchronization	H7	E5
Missing phase, Speed discard	Ld	E5
Malfunction from driving part to main-control communication	P6	E5
IPM module protection	H5	E5
Sensor connection protection	Pd	E5
High-pressure protection	E1	E1
Low-pressure protection	E3	E3
Exhaust protection	E4	E4
Compressor overload protection	H3	E5
Communication malfunction (among indoor unit, outdoor unit and wired controller)	E6	E6
Outdoor ambient temperature sensor malfunction	F3	F3
Coil pipe intermediate temperature sensor malfunction of outdoor unit	F2	F2
Exhaust temperature sensor malfunction	F4	F4
Defrosting (non-malfunction)	08	defrost
Oil return (non-malfunction)	09	no display
Mismatch of indoor unit model	LP	no display
AC current protection (input side)	PA	E5
Driver board environment temperature sensor malfunction	PF	E5
AC input voltage abnormality *	PP	E5
Charge circuit malfunction *	PU	E5
DC fan error	H6	E5

6. Remote Control Operation Procedure(standard fitting)

6.1 Name and Function-Remote Control

Note:

Be sure that there are no obstructions between receiver and remote controller.

Don't drop or throw the remote controller .

Don't let any liquid in the remote controller and put the remote controller directly under the sunlight or any place where is very hot.

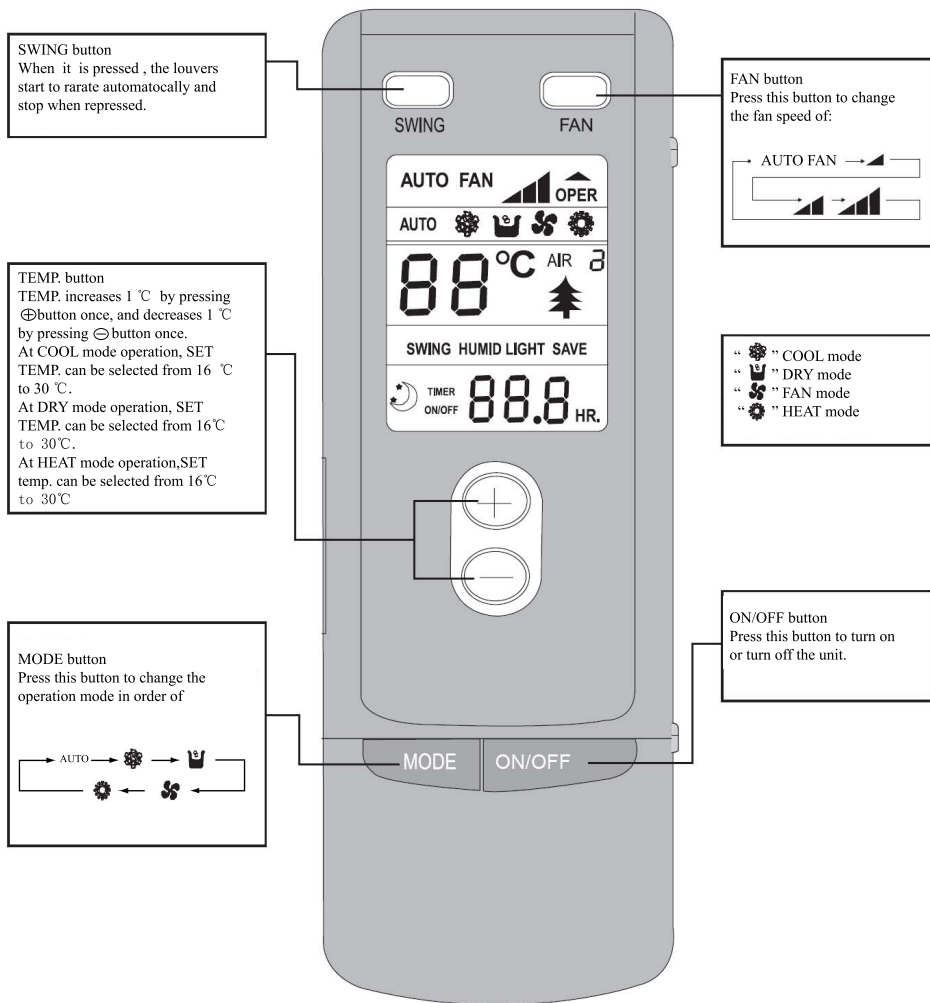

6.2 Name and Function-Remote Control. (Remove the cover)

Note:

This type of remote controller is a kind of new current controller. Some buttons of the controller which are not available to this air conditioner will not be described below.

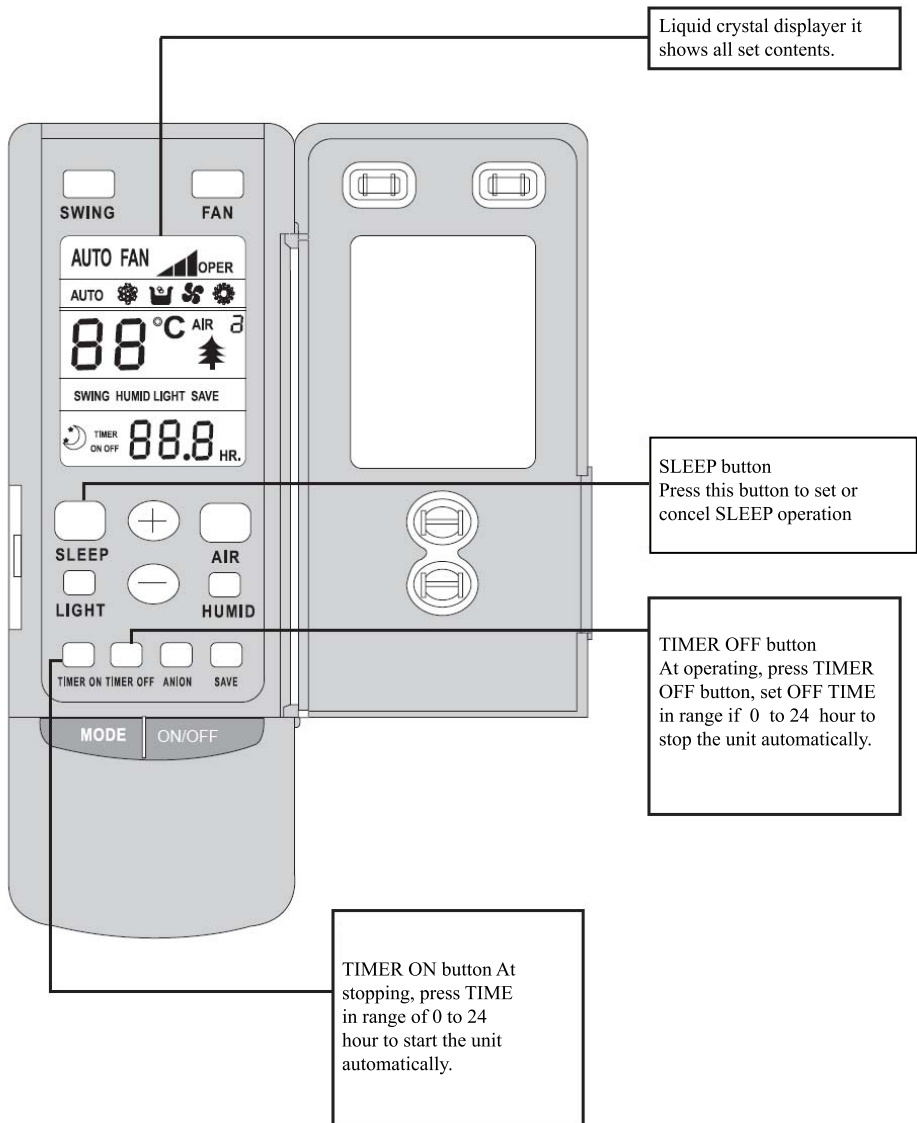

Operate on unmentioned buttons would not impact on the normal use.

6.3 COOL mode operation procedure

According to difference between room temp. and set temp., microcomputer can control cooling on or not. If room temp. is higher than set temp., compressor runs at COOL mode. If room temp. is lower than set temp., compressor stops and only indoor fan motor runs. Set TEMP. should be in range of 16°C to 30°C.

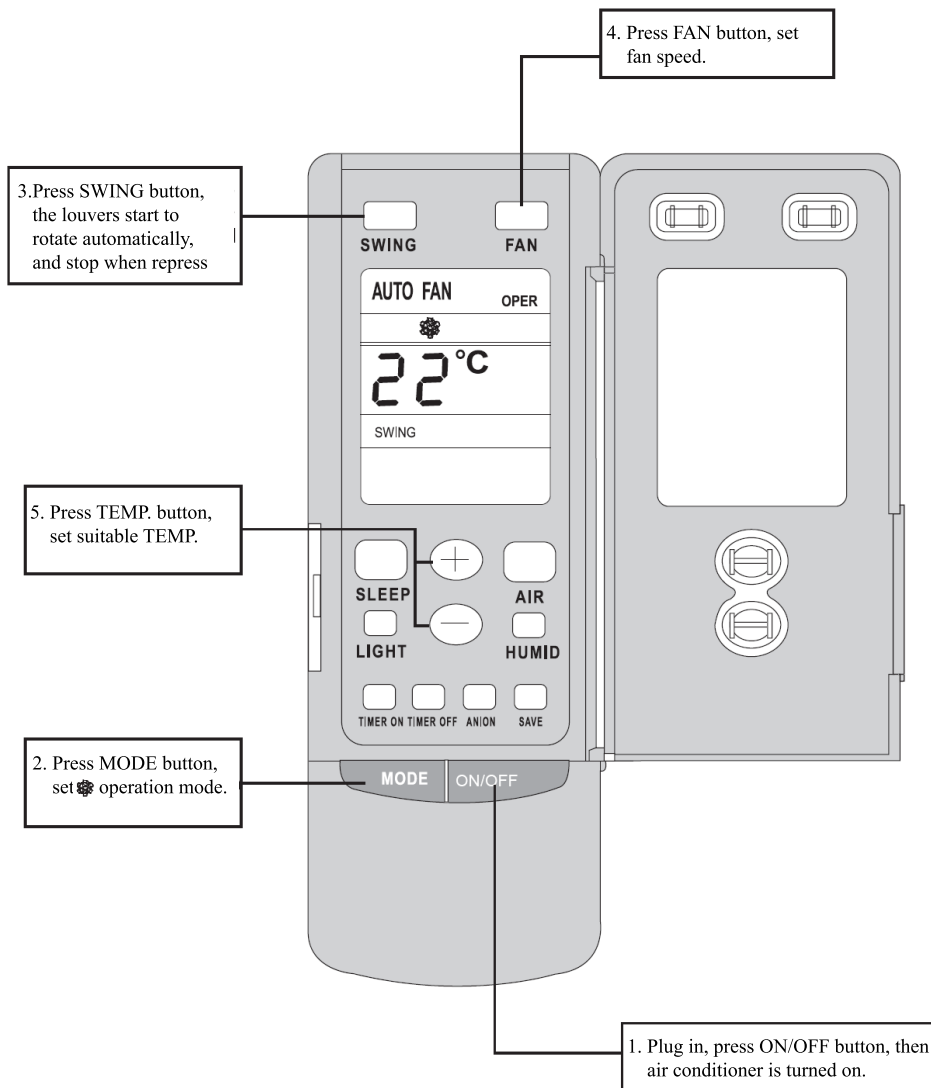

6.4 HEAT mode operation procedure

If room temp. is lower than set temp. compressor runs at HE AT mode;

If room temp. is higher than set temp., compressor and outdoor fan motor stop, only indoor fan motor runs.

Set TEMP. should be in range of 16°C to 30°C.

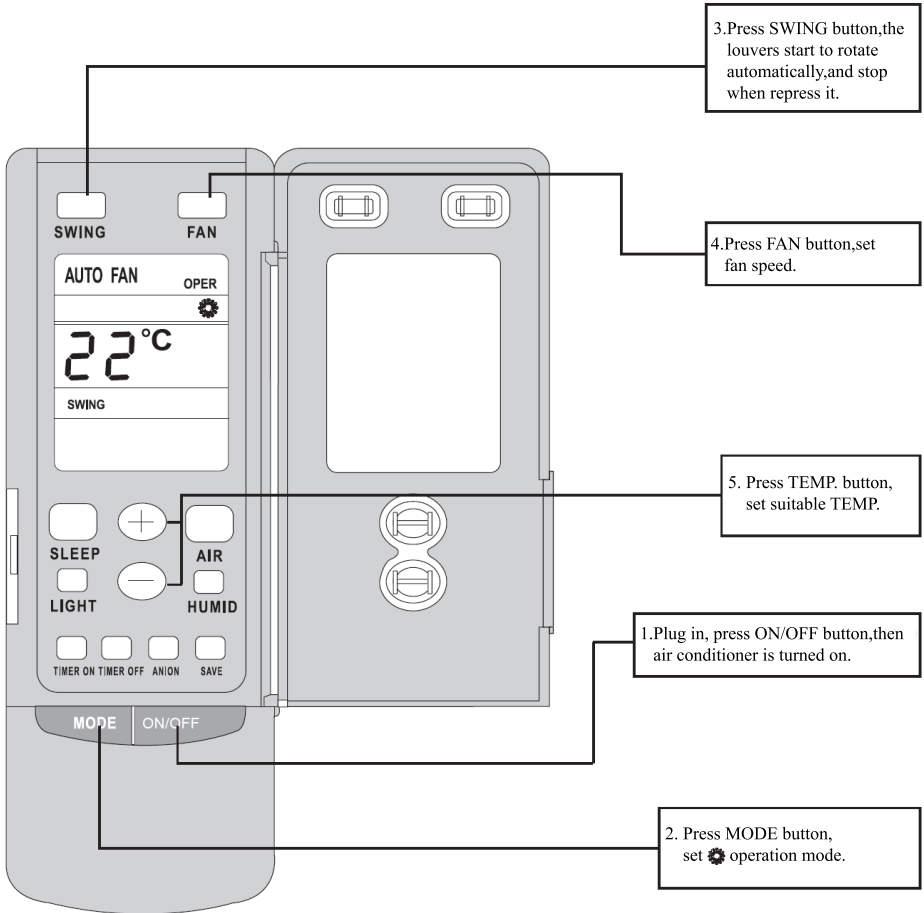

6.5 DRY mode operation procedure

If room Temp. is more than 2°C below Set TEMP. , compressor and outdoor unit fan motor stop, indoor unit fan motor runs at low speed.

If room Temp. is between 2°C of Set TEMP. , the compressor and outdoor unit fan motor will run for 6 minutes and stop for 4 minutes, and always in such a cycle, the indoor unit fan motor will run at low speed.

If room Temp. is more than 2°C above Set TEMP. , compressor and outdoor unit fan motor run as COOL mode , the indoor unit fan motor runs at low speed.

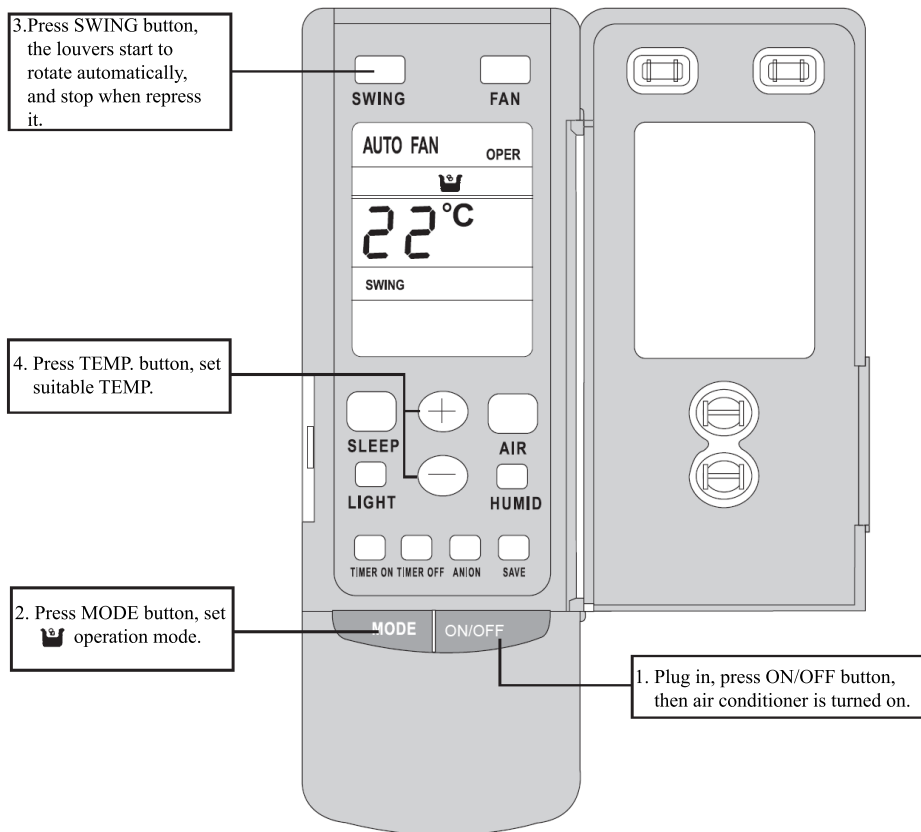

6.6 AUTO mode operation procedure

According to room temp. microcomputer can automatically set COOL. HEAT. DRY operation mode, so as far best effect.

At AUTO mode operation, standard TEMP. is 26°C for COOL mode, 24°C for DRY mode and 20°C for HEAT mode.

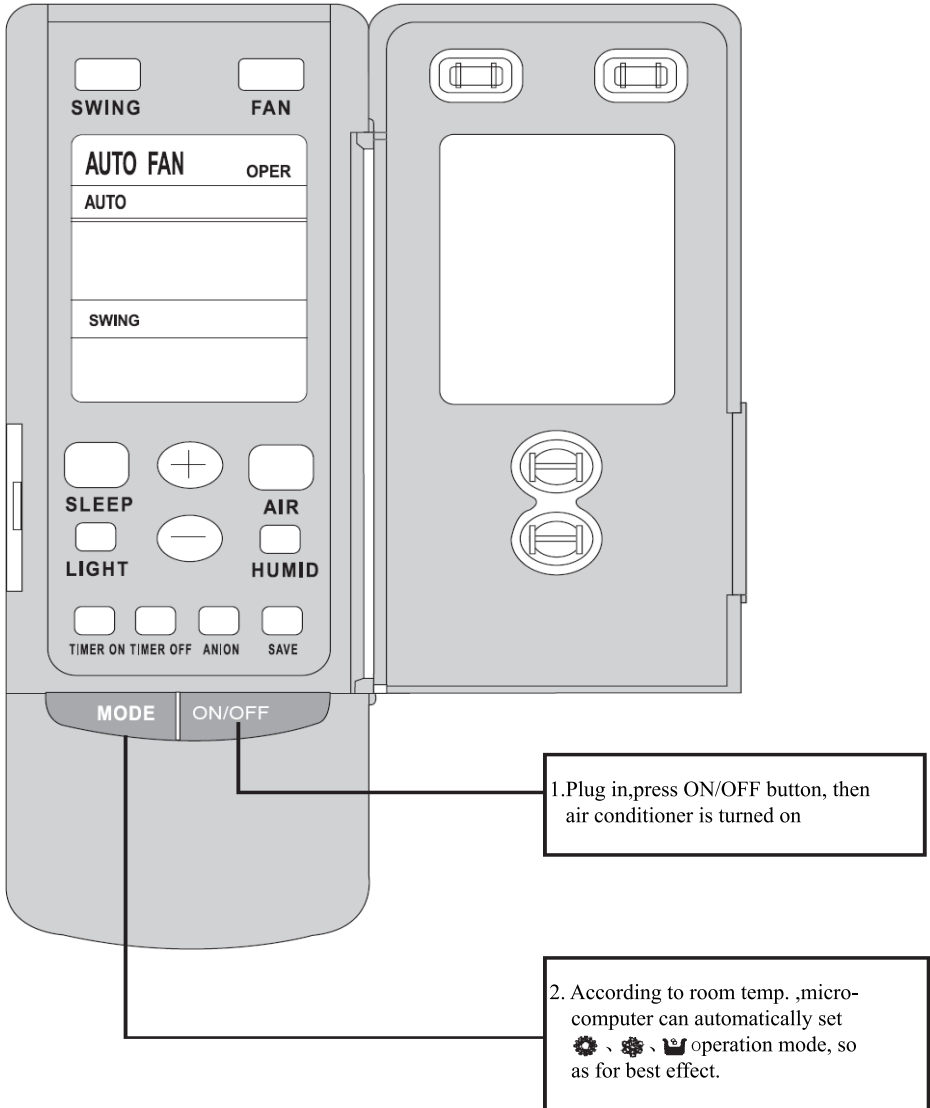

6.7 FAN mode operation procedure

Connect the unit to power supply.

Press the “ON/OFF” key.

Press the mode key to select the “FAN” mode. The unit shall operate under “FAN” mode.

Press the “FAN” key to select from high, medium and low speed.

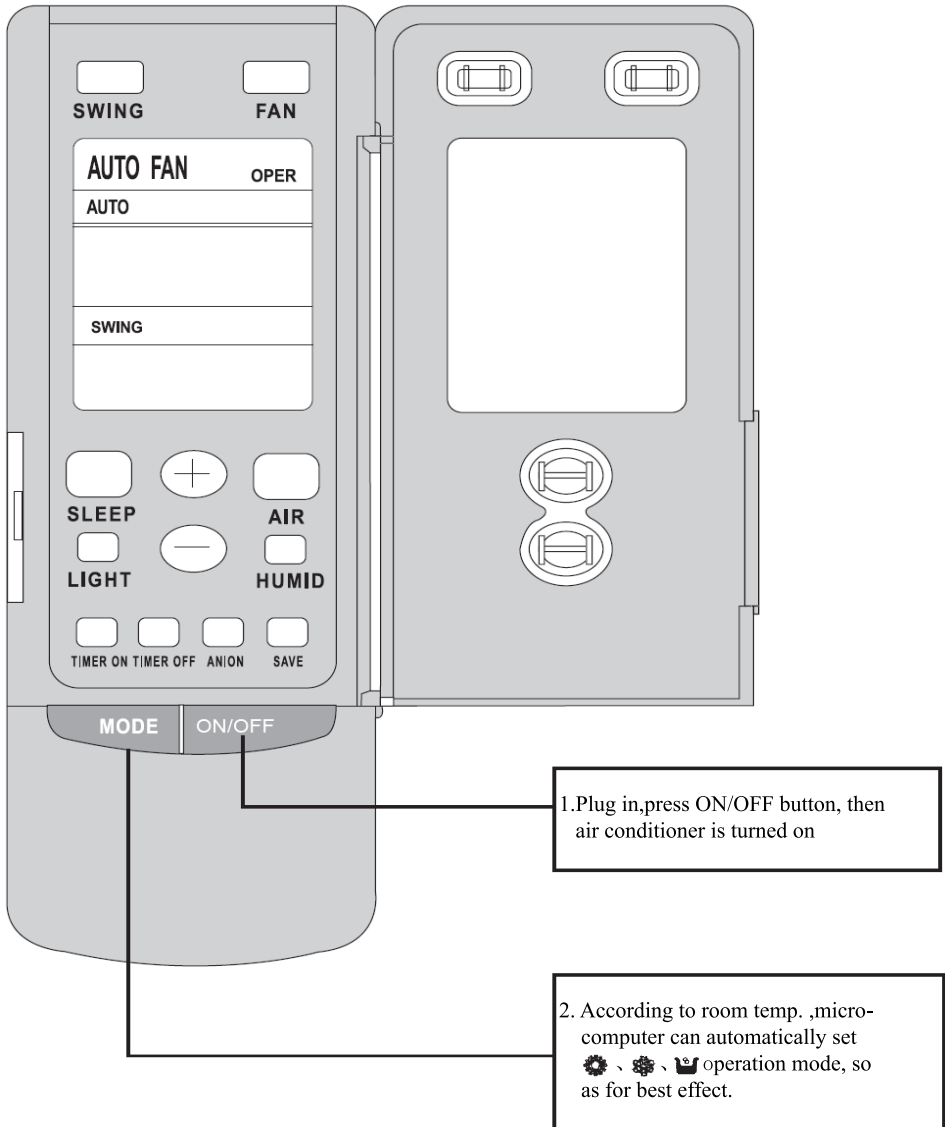

6.8 TIMER operation procedure

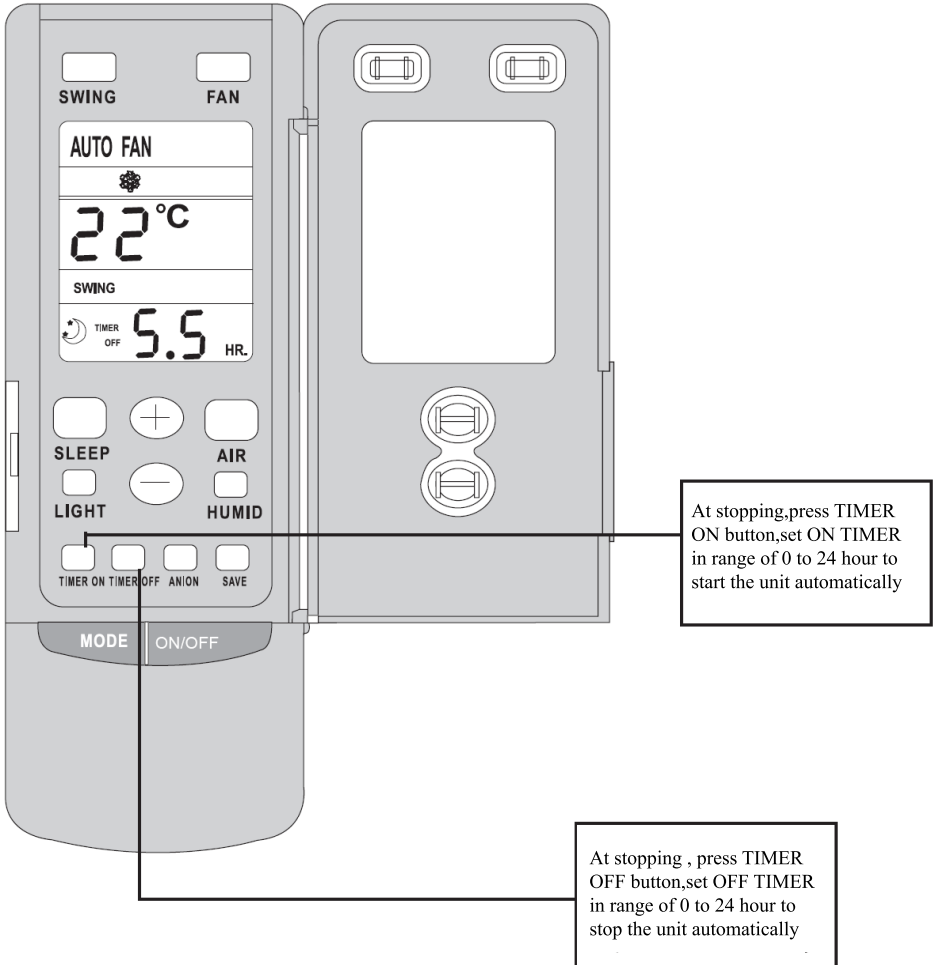

6.9 SLEEP mode operation procedure

When the unit is cooling or drying, if SLEEP operation is set, TEMP. would increase 1°C in 1 hour and 2°C in 2 hours. Indoor fan motor runs at low speed.

When the unit is heating, if SLEEP operation is set, TEMP. would decrease 1°C in 1 hour and 2°C in 2 hours. Indoor fan motor runs at low speed.

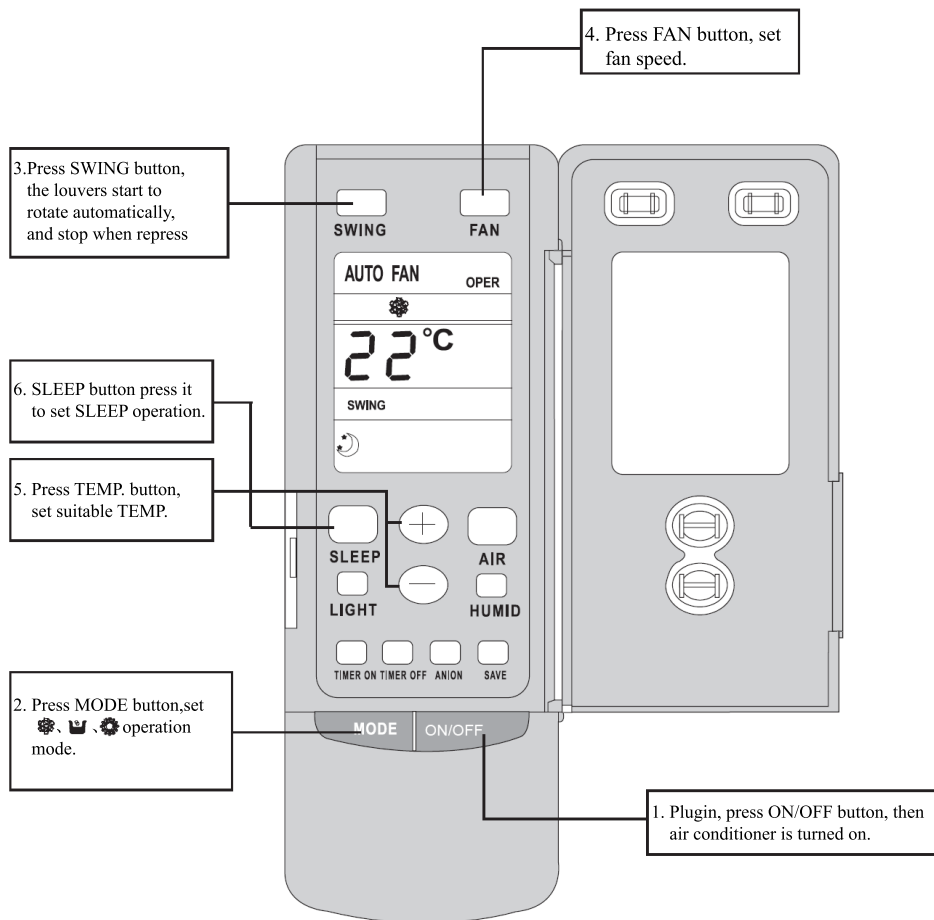

6.10 How to insert batteries

1. Remove the cover from the back of the remote controller.
2. Insert the two batteries (Two AAA dry-cell batteries) and press button "ACL"
3. Re-attach the cover.

NOTE:

- Don't confuse the new and worn or different batteries.
- Remove batteries when not in use for a long time.
- The remote control signal can be received at a distance of up to about 10m.

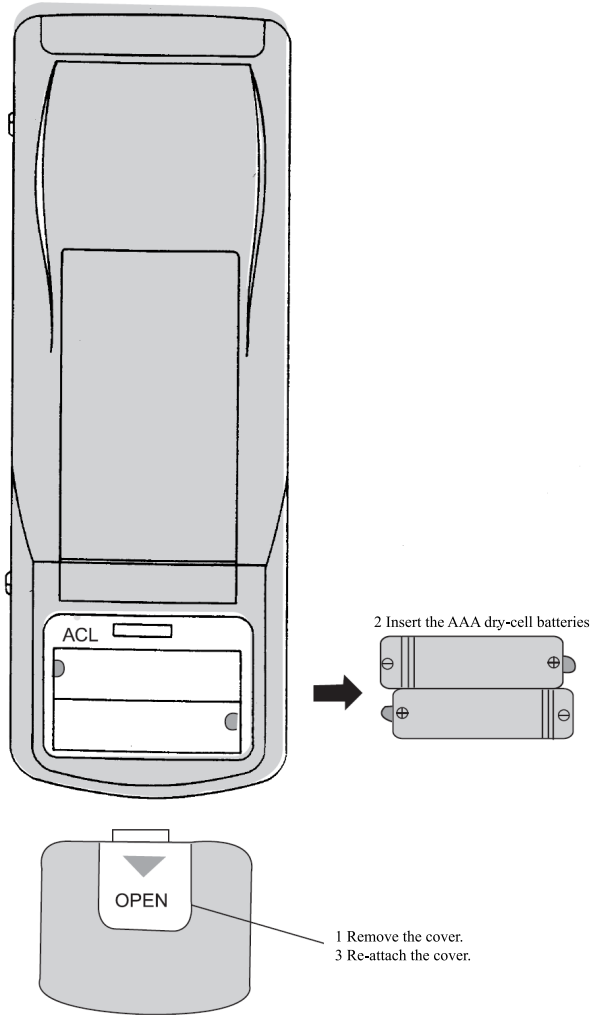

7. Part Names and Their Functions

Remote controller:

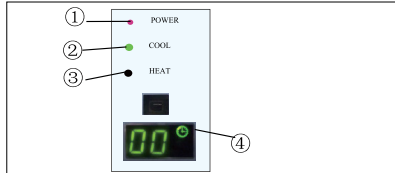

States of the Indicating Lamps:

- ① Indicating Lamp of "POWER": The indicating lamp will shine when power on, while it will go out when power off.
- ② Indicating Lamp of "COOL": The indicating lamp will shine when "COOL" is activated, while it will go out when "COOL" is deactivated.
- ③ Indicating Lamp of "HEAT": The indicating lamp will shine when "HEAT" is activated, while it will go out when "HEAT" is deactivated.
- ④ Indicating Lamp of "TIMER": The indicating lamp will shine when "TIMER" is activated, while it will go out when "TIMER" is deactivated or the set. time is over.

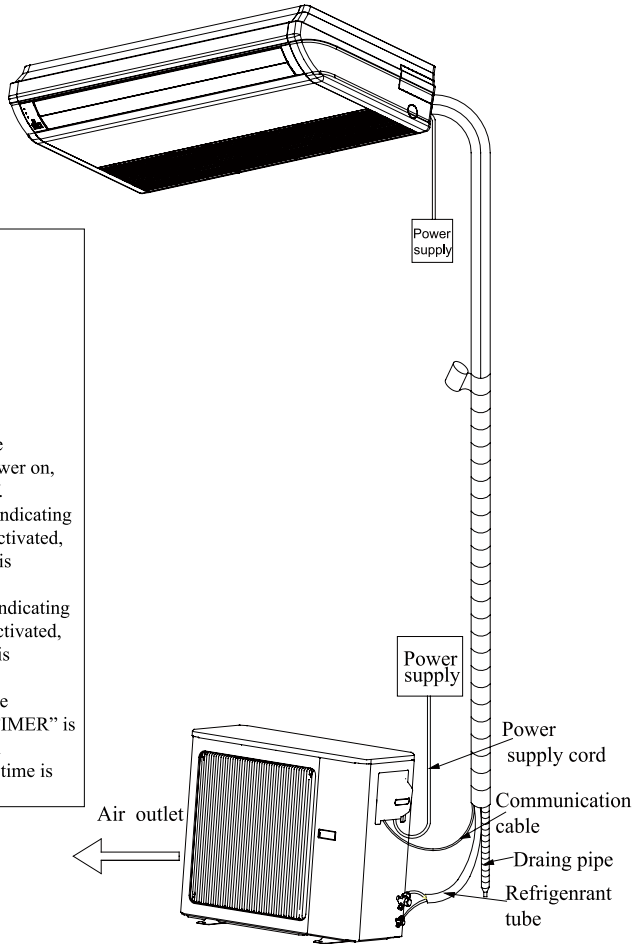

Fig.30

CAUTION:

- Wrong wiring connection will cause electrical malfunction.
- Do not pull the wire when fixing it with wire.

Notes:

- If the supply cord is damaged, it must be replaced by the manufacturer or its service agent or a similarly qualified person in order to avoid a hazard.
- The appliance will be installed in accordance with national wiring regulations.

8. Maintenance

Before inspection and maintenance of the unit, please shut down the unit and set the power switch to “OFF” to cut off the power supply.

① . Cleaning the Air Filter

Remove the air filter; clean it by a vacuum cleaner or if is very dirty, wash it with soap water and then wipe off until it is completely dry before reinstallation.

Suggestion:

If the air filter is dry, it will cause the reduction of airflow, and the unit will be easily overloaded and consumes 6% more energy. So regular cleaning is necessary.

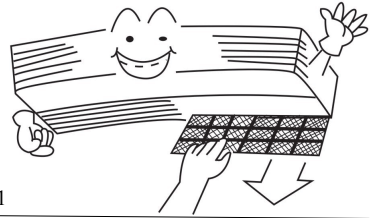

Fig.31

② . Cleaning the Unit

Clean the air conditioner and the remote controller with dry cloth or a vacuum cleaner. If damp cloth is used, remove moisture by using dry cloth afterward.

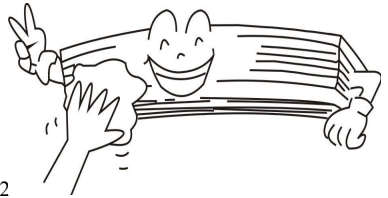

Fig32



CAUTION:

Do not use benzene gasoline, thinners or polishing products for cleaning.

Do not wash with hot water (above 40°C), otherwise some parts of the unit may be deformed.

③ . Before the Seasonal Use

- Ensure that nothing blocks the air inlet and outlet of the indoor and outdoor unit.
- Running the unit without air filters can cause malfunctions due to dirt or dust. Thus, the air filter should be installed at all times.
- Ensure that drainage hose is not bent or clogged.
- Check if the unit is properly installed.

④ . After the Seasonal Use

- Switch off the main switch of the power supply.
- Clean the air filters and other parts (by professionals).
- Leave the fan running along for another 2-3 hours to dry the inside of the unit.

CAUTION:

Wrong wiring connection will cause electrical malfunction.

Do not pull the wire when fixing it with wire.

9. Operating Guide

The cleaning and replacement of the filter is only permitted to be done by the professionals. Before open the grille to clean the filter, please cut off the power supply and wait unit the fan motor stops.

① . The temperature should not be set lower than what you need, otherwise it would result in increased energy cost.

② . To distribute cool air throughout the room, adjust the air flow direction as shown by the arrows (see the picture).

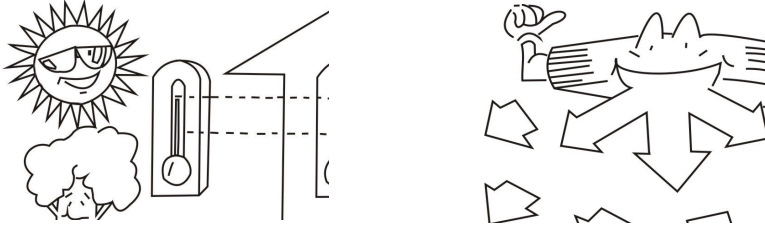

Fig.33

③ . Clean the air filter every week for higher efficiency.

④ . Close the window and door while operating the unit to prevent leakage of cooled air to save energy.



Fig34

⑤ . Draw close the curtains or close glass windows when cooling to prevent heat load from sun light which may cause more electricity cost.

⑥ . In case of ineffective ventilation, open the window to ventilate the room air once in a while but not too long since cooled air will be uselessly drained out.

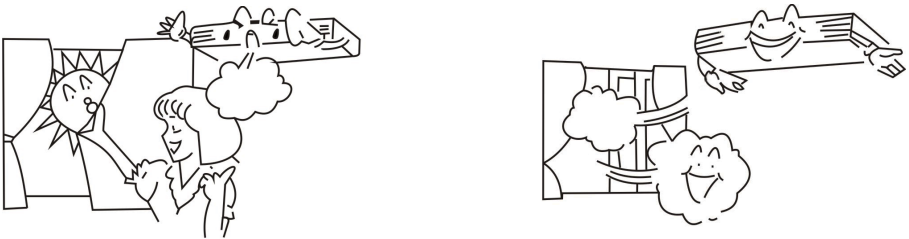

Fig35

10. Precautions

① . Turn off the air conditioner if it is not needed, as electricity interference may occurs while it is running .If the unit is not to be used for a long time, cut off the power supply main switch.

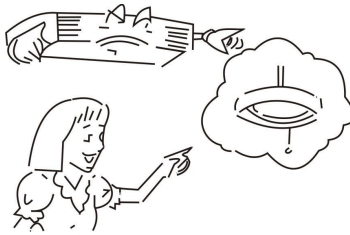

Fig.36

② . Do not insert objects into the air inlet or outlet when the air conditioner is running as it may cause damage or personal injury .Also pay special attention when children are around.

③ . Do not locate any obstacle against the air flow direction of indoor and outdoor unit .Inefficient performance or malfunction may result.

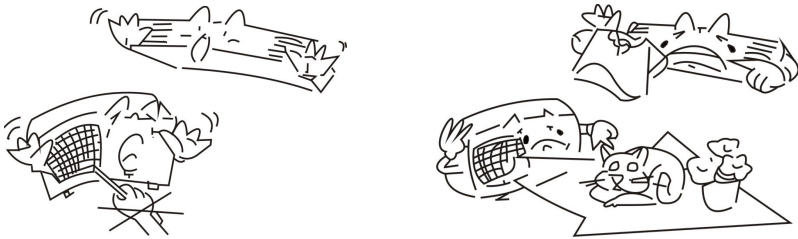

Fig.37

④ . Do not channel the air flow directly at people, especially infants, aged persons, or patients.

⑤ . Do not locate a heater or any other heat source close to the unit. The heat may deform plastic parts.

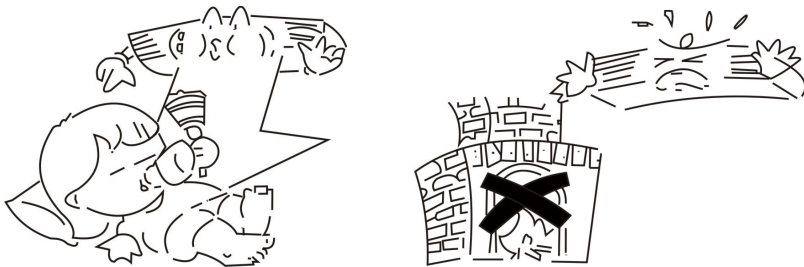

Fig.38

11. Checking Before Contact the Service Man

Check the followings before contact the service man. You may find the solution to your problems.

After checking, if it still does not operate, please contact your local dealer.

Table.3

Problem	Solution(s)
The unit does not run.	<ul style="list-style-type: none"> ● check if the power supply is in order. ● check if the timer switch is on or not.
The air conditioner runs but does not cool enough.	<ul style="list-style-type: none"> ● check if the preset temperature is too high. ● check if the sunlight shines directly into the room. ● check if the door and window are opened. ● check if there is anything blocking the air discharge. ● check if the exhaust fan still operates. ● check if the air filter is dirty or clogged.
Vapor or mist fume comes out from the unit when it runs.	<ul style="list-style-type: none"> ● check if the hot air in the room is mixed with cool air, which may cause smog.
The remote controller works abnormally.	<ul style="list-style-type: none"> ● check if the batteries are inserted in correct directions. ● check if the batteries are exhausted.

11.1 Accessories List for Installation

Table.4











Accessories List for Installation (Outdoor Unit)					
Number	Name	Shape	Quantity	Type	Remark
1	Drainage Hole Cap for Outdoor Unit		1(3)		1 for 09K\12K 3for18\24\30\36\42\48 \60K
2	Drainage Joint for Outdoor Unit		1		Only for heat pump units
<p>Notes: See the packing list to check the delivered accessories. The accessory with * indicates it is not included but should be prepared by the clients themselves.</p>					

Table.5

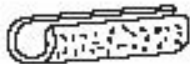
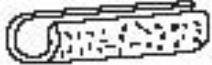
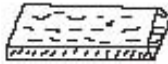
Accessories List for Installation (Indoor Unit)					
Number	Name	Shape	Quantity	Type	Remark
1	Nut (with gasket)		8	M10	
2	Tie Line		4	200mm	
3	Installation Paperboard		1		used for ceiling drilling
4	Thermal Insulation Layer of Discharge Pipe		1		
5	Thermal Insulation Layer of Inlet Liquid Pipe		1		
6	Sealing Plaster*		2		
7	Remote Controller		1		
8	Battery		2		
9	Power Cord *		1	(H05VV-F)3×1.0mm ²	
10	Communication Cable*		1	AWG#24	
11	Drain Hose*		1	Φ17×1.75	
12	Pipe Clamp*		1		
13	Operation		1		

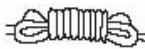
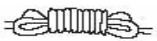
Notes: See the packing list to check the delivered accessories.

The accessory with * indicates it is not included but should be prepared by the clients themselves.

11.2 Installation of the Indoor Unit

When install the indoor unit, you can use a paper pattern for reference and make sure that the drainage side be 10mm lower than the other side in order to drain the condensation water fluently.

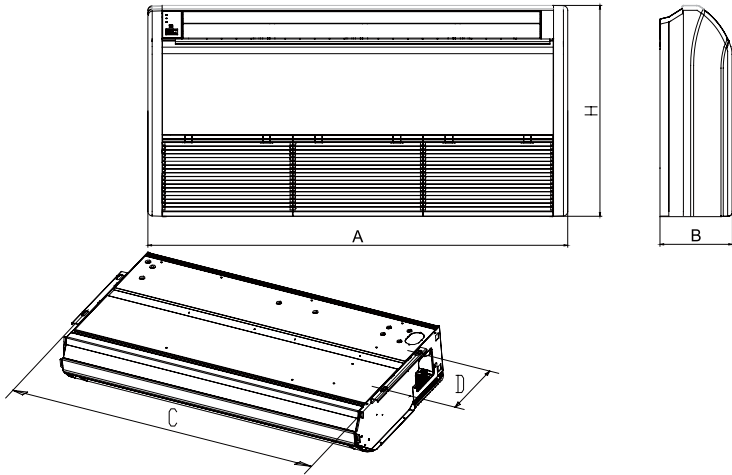

Fig.39

Table.6

Unit: mm

Model	A	B	C	D	H
GTH09K3CI GTH12K3CI GTH18K3CI GTH24K3CI	1220	225	1158	280	700
GTH30K3CI GTH36K3CI GTH42K3CI	1420	245	1354	280	700
GTH48K3CI GTH60K3CI	1700	245	1634	280	700

Cautions for Installation Where Air Conditioner Trouble is Likely to Occur.

- Where there is too much of oil.
- Where it is acid base area.
- Where there is irregular electrical supply.

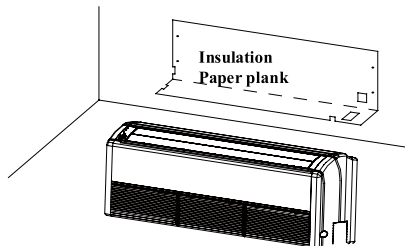

Fig.40

Selection of Installation Location

- ① . Such a place where cool air can be distributed throughout the room.
- ② . Such a place where condensation water is easily drained out.
- ③ . Such a place that can handle the weight of indoor unit.
- ④ . Such a place which has easy access for maintenance.
- ⑤ . Such a place where is easy to connect the outdoor unit.
- ⑥ . Such a place which is 1m or more away from other electric appliances such as television, audio device, etc.
- ⑦ . Avoid a location where there is heat source, high humidity or inflammable gas.
- ⑧ . Do not use the unit in the immediate surroundings of a laundry, a bath, a shower or a swimming pool.
- ⑨ . Ensure that the installation conforms to the installation dimension diagram.
- ⑩ . A space around the unit is adequate for ventilation (See Fig.41)

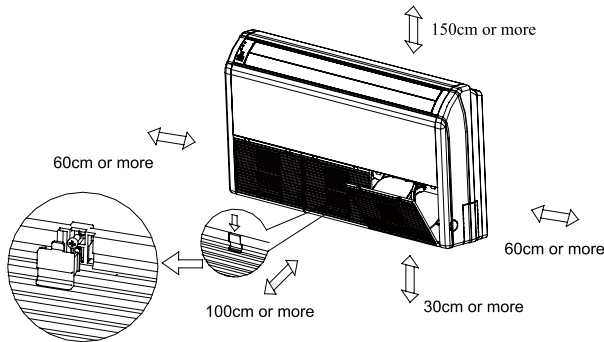

Fig.41

There are two types of installation:

1. Ceiling Type and Floor Type

Each type is similar to the other as follows:

Determine the mounting position on ceiling or wall by using the paper pattern to indicate the indoor frame. Mark the pattern and pull out the paper pattern. Remove the return grill, the side panel and the hanger bracket from the indoor unit as per procedures below.

- ① . Press the fixing knob of the return grilles and Loosen fixing bolts (M4.2). It will be opened widely, and then pull it out from the indoor unit.(See Fig.41)
- ② . Remove the side panel fixing screws and remove it away by pulling it out at the front direction (arrow direction). (See Fig.42)
- ③ . Loosen two hanger bracket setting bolts (M10) on earth side for less than 10mm. Remove two hanger bracket fixing bolts (M6) on the rear side. Detach the hanger bracket by pulling it backward (See Fig.44)

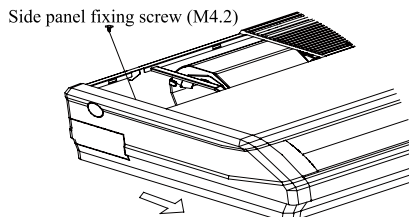

Fig.42

Set the suspension bolt. (Use M10 size suspension bolts)

Adjust the distance between the unit and the ceiling slab beforehand (See Fig.43). Fix the hanger bracket to the suspension bolt.

⚠ WARNING!

- Make sure that extended suspension bolt from the ceiling stays inside the arrowed position. Readjust the hanger bracket when it is outside the arrowed position. (See Fig.45)
- Suspension bolt stays inside the cap of the indoor unit .Never remove the cap. Lift the unit and slide the hanger bracket in the way that the holes on it will match with the corresponding bolts. (See Fig.46)
- Screw tightly both hanger brackets setting bolts (M10.) (See Fig.44)
- Screw tightly both hanger bracket fixing bolts (M6) to prevent the movement of the indoor unit. (See Fig.44)
- Adjust the height of the unit to incline slightly the rear side of the drain pipe so as to optimize the drainage.

⚠ CAUTION!

Adjust the height by turning the unit with a spanner. Insert the spanner from the hanger bracket opening. (See Fig. 48)

2. Hanging and Mounting

It is possible to carry out the installation by using inward facing hanger brackets without moving the brackets from the indoor unit. (See Fig.47)

Be sure to use only the specified accessories and parts for installation.

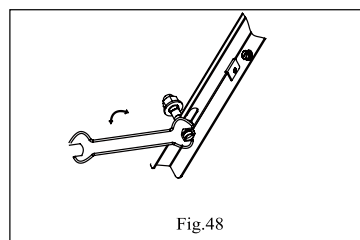
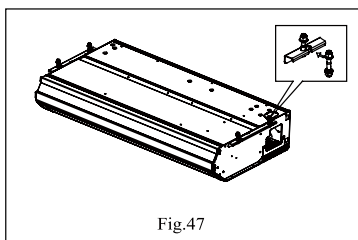
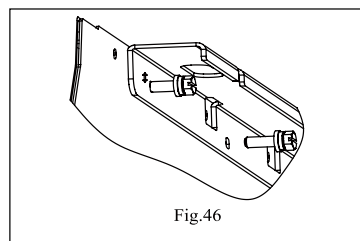
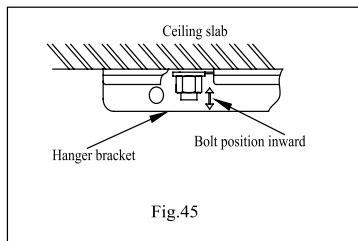
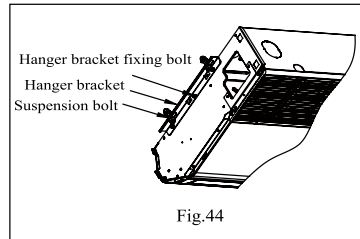
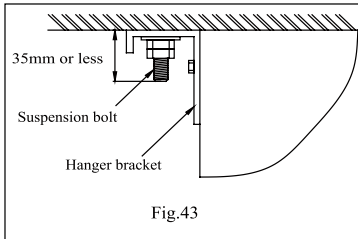

11.3 Installation of the Outdoor Unit

11.3.1 Installation Location of the Outdoor Unit

The foundation must be solid enough to bear the weight and vibration of the unit.

The space around the unit is adequate for ventilation.

The location is not close to any inflammable gases.

The location is sufficiently isolated so that the running noise and the hot exhaust air do not disturb the users or their neighbors.

There is an easy access to check and maintenance.

Ensure the spaces indicated by arrows to the wall, ceiling, fence, or other obstacles.

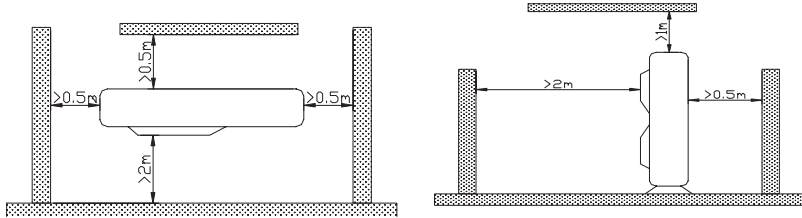

Fig.49



CAUTION

Installation in the following places may cause problems.

If it is unavoidable to select such places, consult with your distributor or dealer.

- A place with machine oil
- A saline place such as a place very close to seashore
- A place with corrosive gas
- A place where high-frequency waves are generated by the radio equipment, welder or medical equipment.

11.3.2 Electric Wiring Connection

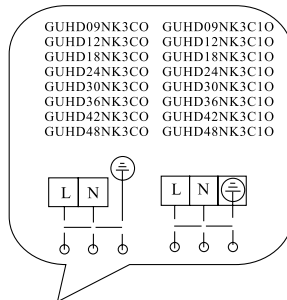

Fig.50

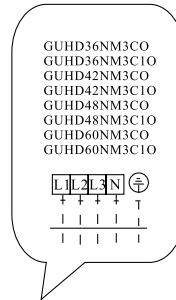

Fig.51



CAUTION!

- ① . Wrong wiring may cause fire or electric shock.
- ② . Do not pull the wire when fixing it .
- ③ . With wire clamps and clasps.
- ④ . Do not let the wire too loose
- ⑤ . All the electrical work must be done by qualified personnel according to the local rules and this

instruction

- ⑥ . The rated voltage and the exclusive circuit must be used.
- ⑦ . Leakage circuit-breaker must be installed.
- ⑧ . Please use the specified fuse.
- ⑨ . If the power supply cord of the unit is damaged it must be replaced by the manufacturer or its service agent or a similarly qualified person in order to avoid a hazard.
- ⑩ . An all-pole disconnection air switches which have a contact separation of at least 3mm in all poles is needed

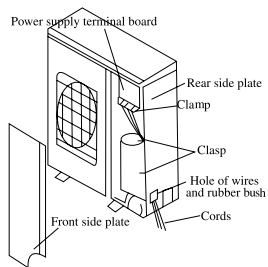

11.3.3 Profile Dimensions of the Outdoor Unit

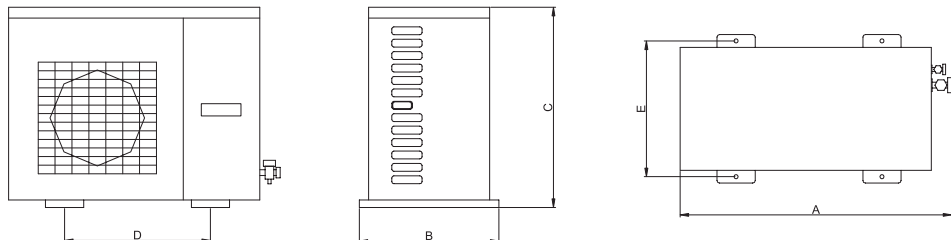

Fig.53
Table.7

Unit: mm

Item Model	A	B	C	D	E
GUHD09NK3CO GUHD12NK3CO	776	320	540	510	286
GUHD09NK3C1O GUHD12NK3C1O	848	320	540	540	286
GUHD18NK3CO GUHD18NK3C1O	955	396	700	560	360
GUHD24NK3CO GUHD24NK3C1O	980	427	790	610	395
GUHD30NK3CO GUHD30NK3C1O					
GUHD36NK3CO GUHD36NK3C1O GUHD36NM3CO GUHD36NM3C1O	1107	440	1100	631	400
GUHD42NK3CO GUHD42NK3C1O GUHD42NM3CO GUHD42NM3C1O					
GUHD48NK3CO GUHD48NK3C1O GUHD48NM3CO GUHD48NM3C1O	1085	427	1365	620	395
GUHD60NM3CO GUHD60NM3C1O					

11.3.4 Precautions on Installation of the Outdoor Unit

To ensure the unit in proper function, the installation location must be selected in accordance with following principles:

- ① . Outdoor unit should be installed in the way that the air discharged by out door unit will not return and that sufficient space for repair will be provided around the machine.
- ② . The installation site must have good ventilation, so that the outdoor unit can take in and exhaust enough air. Ensure that there is no obstacle to the air intake and exhaust of the outdoor unit. If there is any obstacle blocking the air intake or exhaust, remove it.
- ③ . Place of installation should be strong enough to support the weight of outdoor unit, and it should be able to insulate noise and prevent vibration. Ensure that the wind and noise from the unit will not affect your neighbors.
- ④ . Avoid direct sunshine over the unit. It is better to set up a sun shield as a protection.
- ⑤ . Place of installation must be able to drain the rainwater and defrosting water.
- ⑥ . Place of installation must ensure the machine will not be buried under snow or subject to the influence of rubbish or oil fog.
- ⑦ . The installation site must be at a place where the air exhaust outlet does not face strong wind.

11.4 Schematic Diagram of Unit Line Connection

Electric wiring connection:

The section area of cables selected by users must not be smaller than the specifications shown in the following diagram. The signal wire between indoor and outdoor unit will be installed in the shielded bushing

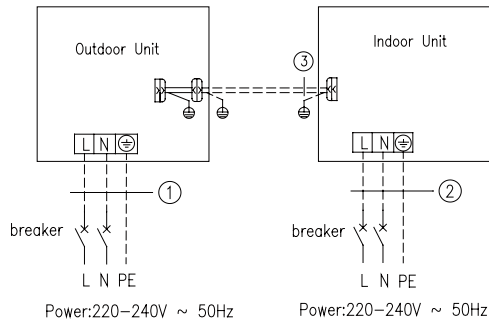

Fig.54-1

GUHD09NK3CO + GTH09K3CI GUHD12NK3CO + GTH12K3CI 1.Power cord 3×2.5 mm ² (H07RN-F) 3.Communication Cords	GUHD09NK3C1O + GTH09K3CI GUHD12NK3C1O + GTH12K3CI 2.Power cord 3×1.0 mm ² (H05VV-F)
GUHD36NK3CO + GTH36K3CI 1.Power cord 3×4.0 mm ² (H07RN-F) 3.Communication Cords	GUHD36NK3C1O + GTH36K3CI 2.Power cord 3×1.0 mm ² (H05VV-F)
GUHD42NK3CO + GTH42K3CI 1.Power cord 3×4.0 mm ² (H07RN-F) 3.Communication Cords	GUHD42NK3C1O + GTH42K3CI 2.Power cord 3×1.0 mm ² (H05VV-F)
GUHD48NK3CO + GTH48K3CI 1.Power cord 3×6.0 mm ² (H07RN-F) 3.Communication Cords	GUHD48NK3C1O + GTH48K3CI 2.Power cord 3×1.0 mm ² (H05VV-F)

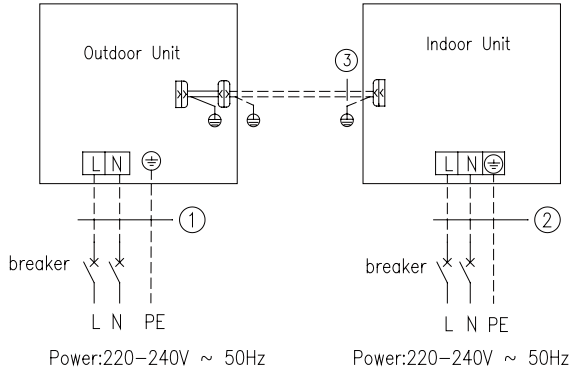

Fig.54-2

GUHD18NK3CO + GTH18K3CI	GUHD18NK3C1O + GTH18K3CI
GUHD24NK3CO + GTH24K3CI	GUHD24NK3C1O + GTH24K3CI
GUHD30NK3CO + GTH30K3CI	GUHD30NK3C1O + GTH30K3CI

1. Power cord $3 \times 4.0 \text{ mm}^2$ (H07RN-F)
2. Power cord $3 \times 1.0 \text{ mm}^2$ (H05VV-F)
3. Communication Cords

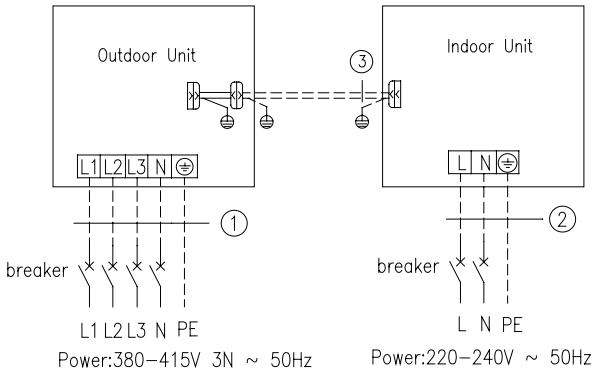
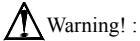

Fig.55

GUHD36NM3CO + GTH36K3CI	GUHD36NM3C1O + GTH36K3CI
GUHD42NM3CO + GTH42K3CI	GUHD42NM3C1O + GTH42K3CI
GUHD48NM3CO + GTH48K3CI	GUHD48NM3C1O + GTH48K3CI
GUHD60NM3CO + GTH48K3CI	GUHD60NM3C1O + GTH60K3CI

1. Power cord $5 \times 2.5 \text{ mm}^2$ (H07RN-F)
2. Power cord $3 \times 1.0 \text{ mm}^2$ (H05VV-F)
3. Communication Cords

The following table recommended by the model selection manual is about how to select the air switch and power cable.



Warning! :

The section area of cables selected by users must not be smaller than the specifications shown in the table below.

Table.8

Model	Power Supply	Capability of Air Switch(A) (Outdoor/Indoor)	Minimum Sectional Area Of Earth Wire (mm ²) (Outdoor/Indoor)
GUHD09NK3CO	220-240V~ 50Hz	16/6	2.5/1.0
GUHD09NK3C1O			
GUHD12NK3CO		16/6	2.5/1.0
GUHD12NK3C1O			
GUHD18NK3CO		20/6	4.0/1.0
GUHD18NK3C1O			
GUHD24NK3CO		20/6	4.0/1.0
GUHD24NK3C1O			
GUHD30NK3CO		20/6	4.0/1.0
GUHD30NK3C1O			
GUHD36NK3CO		25/6	4.0/1.0
GUHD36NK3C1O			
GUHD42NK3CO		25/6	4.0/1.0
GUHD42NK3C1O			
GUHD48NK3CO		32/6	6.0/1.0
GUHD48NK3C1O			
GUHD36NM3CO	380-415V 3N~ 50Hz	16/6	2.5/1.0
GUHD36NM3C1O			
GUHD42NM3CO		16/6	2.5/1.0
GUHD42NM3C1O			
GUHD48NM3CO		16/6	2.5/1.0
GUHD48NM3C1O			
GUHD60NM3CO		16/6	2.5/1.0
GUHD60NM3C1O			

Note: The parameters of the power cord listed above are only applicable to the BV single-core power cord which is laid within the plastic bushing and used at 40°C, and those of the air switch are applicable to the one which also is used at 40°C. If the actual installation conditions changes, please refer to the instructions of the power cord and the air switch.

Rated Parameters and Outline Dimensions of the Fuse

Table.9

Unit	Code	Rated parameter	Dimensions
GUHD09NK3CO GUHD12NK3CO	46010408/ 46010029	250V/15A 250V/3.15A	
GUHD09NK3C1O GUHD12NK3C1O	46010408/ 46010014		
GUHD18NK3CO GUHD18NK3C1O	46010014/ 46010023	250V/3.15A, 250V/30A	
GUHD24NK3CO GUHD24NK3C1O	46010014/ 46010023	250V/3.15A, 250V/30A	
GUHD30NK3CO GUHD30NK3C1O	46010014/ 46010023	250V/3.15A, 250V/30A	
GUHD36NK3CO GUHD36NK3C1O	46010014/ 46010023	250V/3.15A, 250V/30A	
GUHD42NK3CO GUHD42NK3C1O	46010014/ 46010023	250V/3.15A, 250V/30A	
GUHD48NK3CO	46010014	250V/3.15A	
GUHD48NK3C1O	46010013	250V/5A	
GUHD36NM3CO GUHD36NM3C1O	46010014	250V/3.15A	
GUHD42NM3CO GUHD42NM3C1O	46010014	250V/3.15A	
GUHD48NM3CO GUHD48NM3C1O	46010013	250V/5A	
GUHD60NM3CO GUHD60NM3C1O	46010013	250V/5A	
GUHD60NM3CO GUHD60NM3C1O	46010013	250V/5A	
All the indoor units	46010013	250V/5A	

11.5 Connecting Pipe Preparation

11.5.1 Pipe Preparation

1. Pipe & Electrical Wire Cutting

- Use cutting tools easily found in the market.
- Measure precisely both outer & inner pipes.
- The length of the pipe should be a little longer than the actual measured value.
- The wire should be 1.5m longer than the refrigerant tube.

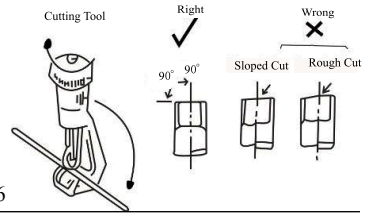

Fig.56

2. Reaming

- Clean the inside of the inner refrigerant tube.
- While reaming, the tube end must be on the top of the reamer to prevent any dust going back into the tube.

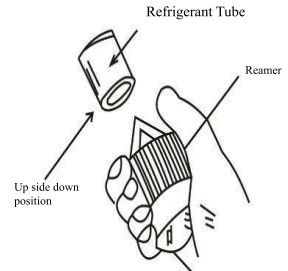

Fig.57

3. Flaring the Pipe End

- Flare both ends of the pipe with flaring kits by fitting the flare nut on the pipe before flaring. Set the die on the pipe in the way that the pipe end is 0.5mm above the top of the die. Then, check if the pipe end is even and perfectly round or not.

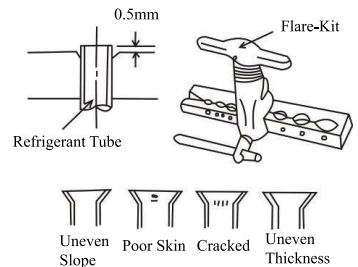

Fig.58

4. Wire Connecting and Taping

- (See the figure on right)

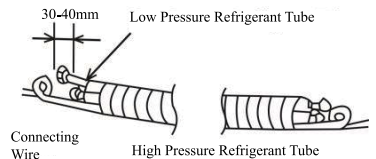

Fig.59

To Indoor Unit

To Outdoor Unit

11.5.2 Refrigerant Piping work

The refrigerant is R410A for" GUHD*NK3CO /GUHD*NM3CO/ GUHD*NK3C1O /GUHD*NM3C1O " series outdoor units, GWP=2020 ODP=0

The standard pipe length is 5m. When the length (L) of the connecting pipe is less than or equals 7m, there is no need to add refrigerant. If the connecting pipe is longer than 7m, it is required to add refrigerant. In the below table, the amounts of refrigerant to be added for different models are listed for each additional meter of pipe length.

Select copper pipes for gas and liquid as informed in specific table (see the pipe table below).For dust and moisture protection, before assembly of the pipe and its insulation, both ends of the pipe must be covered.

Table.10

Model \ Item	Size of Fitting Pipe (Inch)		Max Pipe Length (m)	Max Height Difference between Indoor Unit and Outdoor Unit(m)	Amount of Additional Refrigerant to Be Filled (For Extra Length of Pipe)	Indoor Unit Drainage Pipe (Diameter × Wall Thickness) (mm)
	Gas Pipe	Liquid Pipe				
GTH09K3CI GUHD09NK3CO GTH09K3CI GUHD09NK3C1O	3/8	1/4	20	15	30 g/m	Φ17×1.75
GTH12K3CI GUHD12NK3CO GTH12K3CI GUHD12NK3C1O						
GTH18K3CI GUHD18NK3CO GTH18K3CI GUHD18NK3C1O						
GTH24K3CI GUHD24NK3CO GTH24K3CI GUHD24NK3C1O	5/8	3/8	30	15	60 g/m	
GTH30K3CI GUHD30NK3CO GTH30K3CI GUHD30NK3C1O						
GTH36K3CI GUHD36NK3CO GTH36K3CI GUHD36NK3C1O						
GTH42K3CI GUHD42NK3CO GTH42K3CI GUHD42NK3C1O			50	30		
GTH48K3CI GUHD48NK3CO GTH48K3CI GUHD48NK3C1O						
GTH36K3CI GUHD36NM3CO GTH36K3CI GUHD36NM3C1O			30	15		
GTH42K3CI GUHD42NM3CO GTH42K3CI GUHD42NM3C1O						
GTH48K3CI GUHD48NM3CO GTH48K3CI GUHD48NM3C1O						
GTH60K3CI GUHD60NM3CO GTH60K3CI GUHD60NM3C1O			3/4	3/8		

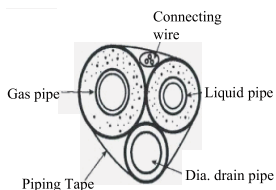

Fig.60

Avoid pipe bending as much as possible, if it is necessary, the bending radius must be more than 3 or 4 cm.

Connection between an Indoor unit and an Outdoor Unit:

- ① . Unscrew the flare nut for releasing pressure gas in the indoor unit. If there is no high pressure gas blowing out, it is the signal of leakage for the indoor unit.
- ② . Fit the flare nut to the liquid pipe. Flare the pipe's end with flare tools.
- ③ . Tighten both flare nuts into gas pipe and liquid pipe at the indoor unit with two spanners.

11.5.3 Air Purging

The purpose of the air purging is to get rid of moisture and air in the system, otherwise moisture and air may cause ineffectiveness of the compressor which directly affects the cooling capacity.

Purging by Using Vacuum

After tightening the flared nuts between the indoor and the outdoor unit

- Remove the blank cap of a three-way valve by using a torque wrench, and then check if both high pressure and low pressure valves are in closed condition or not.
- Remove the nut at the service port.
- Connect a gauge into the service port and a vacuum pump.
- Remove the gauge and tighten up the nut at the service port.
- Use a hexagonal wrench to open both high pressure and low pressure valves to the end (counter clockwise).
- Tighten the blank cap of the three-way valve.

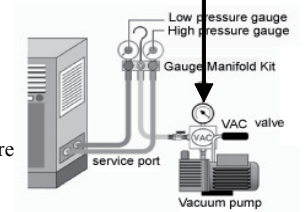
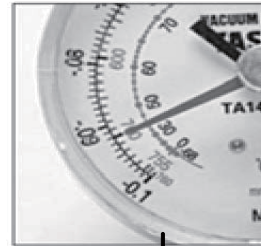

Fig.61

Gap Leakage Check

- Check if it leaks or not by applying soapsuds on every joint and then inspect carefully. After the check, wipe them off completely.
- Cover the indoor unit joint with pipe insulation and four plastic bands to prevent condensing at joints.

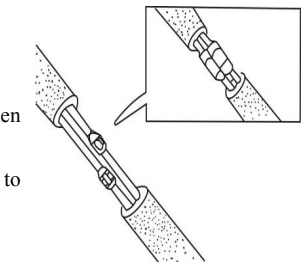

Fig.62

11.5.4 Liquid Pipe and Drain Pipe

If the outdoor unit is installed lower than the indoor unit (See Fig.63).

- A drain pipe should be above ground and the end of the pipe does not dip into water. All pipes must be restrained to the wall by saddles.
- Taping pipes must be done from bottom to top.
- All pipes are bound together by tape and restrained to wall by saddles.

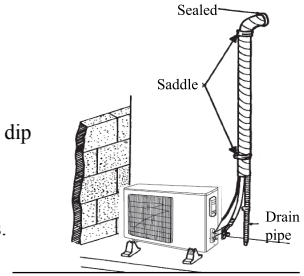

Fig.63

If the outdoor unit is installed higher than the indoor unit (See Fig.64).

- Taping should be done from lower to the upper part.
- All pipes are bound and taped together and also should be trapped to prevent water from returning to the room (See Fig.64)
- Restraint all pipes to the wall with saddles.

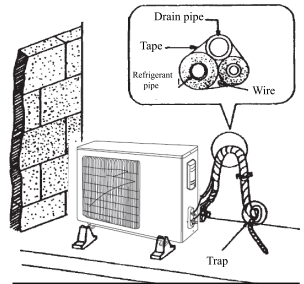

Fig.64

11.5.5 Drain Pipe

⚠ CAUTION: make sure the drain flows out.

Drain pipe

- The drain pipe outlet direction can be chosen from either the right rear or right.
- The diameter of the drain pipe should be equal to or greater than the diameter of the connecting pipe. (Vinyl tube: pipe size:20 mm, outer dimension: 26mm)
- Keep the drain pipe as short as possible and incline downwards at a gradient of at least 1/100 to prevent air pockets (See Fig.65)
- Use the drain hose ④ and clamp ⑤. Insert the drain hose completely into the drain socket, and tighten the clamp within the range of the gray tape unit the screw head is less than 4mm above the hose (See Fig.66, 67)
- Insulate the clamp and drain hose by wrapping the sealing pad over them.
- No folding of the drain hose is allowed in the indoor unit. (See Fig.68)

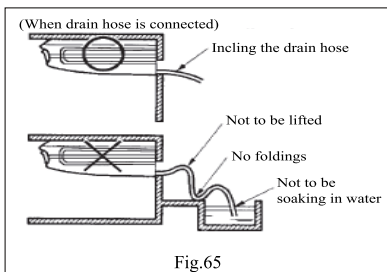

Fig.65

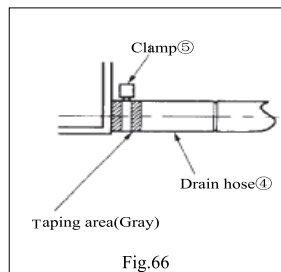
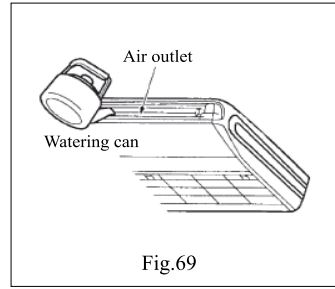
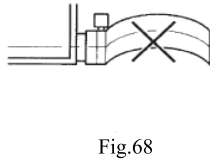
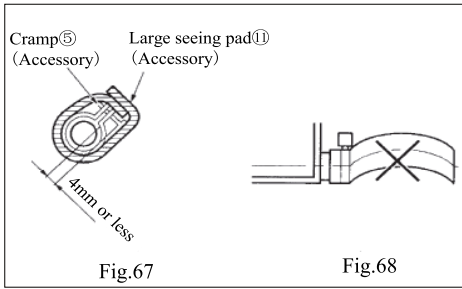

Fig.66



Confirm that smooth drainage is achieved after the pipe working.

Inject 600cc water into the drain pan from the air outlet to see if the drainage goes well or not. (See Fig.69)

11.5.6 Routine Checks after Installation

Check after installation

Table.11

Items to be checked	Possible Malfunction(s)	Items to be checked
Has it been fixed firmly?	The unit may drop, shake or emit noise.	Has it been fixed firmly?
Have you done the refrigerant leakage test?	It may cause insufficient refrigerating capacity.	Have you done the refrigerant leakage test?
Is the heat insulation sufficient?	It may cause condensation and dripping.	Is the heat insulation sufficient?
Does the unit drain well?	It may cause condensation and dipping.	Does the unit drain well?
Is the voltage in accordance with the rated voltage marked on the nameplate?	It may cause electric malfunction or damage the part.	Is the voltage in accordance with the rated voltage marked on the nameplate?
Is the electric wiring and piping connection installed correctly and securely?	It may cause electric malfunction or damage the part	Is the electric wiring and piping connection installed correctly and securely?
Has the unit been connected to a secure earth connection?	It may cause electric leakage.	Has the unit been connected to a secure earth connection?
Is the power cord specified?	It may cause electric malfunction or damage the part.	Is the power cord specified?
Have the inlet and outlet been covered?	It may cause insufficient refrigerating capacity.	Have the inlet and outlet been covered?
Has the length of the connection pipes and the refrigerant charge been recorded?	The refrigerating capacity may be not accurate.	Has the length of the connection pipes and the refrigerant charge been recorded?

⚠ WARNING! :

This appliance is not intended for use by persons (including children) with reduced physical sensory or capabilities, or lack of experience and knowledge, unless they have been given supervision or instruction concerning the use the appliance by a person responsible for their safety.

Children should be supervised to ensure that they do not play with this appliance.

11.5.7 Test Running

Evaluation of the Performance

Check the voltage of the main electrical wire.

Use a thermometer to measure both inlet and outlet cool air.

The difference between inlet air and outlet air temperature should not be less than 8°C

The unit has the function of auto-restart and it can remember the running mode before power failure

Be sure to use the exclusive accessories listed above in the installation instructions, or it may result in water leakage, electric shock, fire, etc.

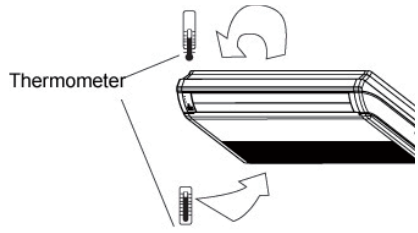

Fig.70

12. Appendix

Air conditioner nominal working condition and working range:

Test condition	Indoor side		Outdoor side	
	DB(°C)	WB(°C)	DB(°C)	WB(°C)
Nominal cooling	27	19	35	24
Nominal heating	20	--	7	6
Rated cooling	32	23	48	--
Low temp cooling	21	15	18(-15)	--
Rated heating	27	--	24	18
Low temp heating	20	--	-7	-8

Note:

- The design of this unit conforms to the requirements of EN14511 standard.
- The air volume is measured at the 0Pa external static pressure.
- Cooling (heating) capacity stated above is measured under nominal working conditions corresponding to 0Pa external static pressure. The parameters are subject to change with the improvement of products, in which case the values on the nameplate will prevail.
- In this table, the outdoor side DB temperature of low temp cooling include two values, the one in the bracket is the working condition of the appliance with function of low temp cooling.



This product must not be disposed together with the domestic waste. This product has to be disposed at an authorized place for recycling of electrical and electronic appliances.

Gree Electric Appliances, Inc. of Zhuhai

Jin Ji West Road, Qianshan, Zhuhai, Guangdong 519070 P.R. China

<http://www.gree.com>