



Service Manual

U-Match 5 SERIES UNIT SERVICE MANUAL

Capacity: 3.5KW~16.0KW

Rate Frequency: 50/60Hz

Operation Range: -20°C~48°C







Foreword

Thank you for choosing Gree U-Match air conditioners. In order to correctly install and use our units, and for the satisfactory operation effect, please read this manual carefully.

This manual specifies safe operation requirements from perspectives of product introduction, control, troubleshooting and maintenance, as well as basic principles and implementation methods. Professional operators must abide by relevant national (local) safety requirements and technical specifications set forth in this manual during operations; otherwise, the air conditioning system may fail or be damaged, and personnel safety accident may also occur.

Safety Notice

	The air conditioner is charged with inflammable refrigerant R32.
	Before using the air conditioner, please first read the instruction manual.
	Before installing the air conditioner, please first read the instruction manual.
	Before repairing the air conditioner, please first read the technical service manual.

Compared with common refrigerant, R32 is an environmental-friendly refrigerant that has no harm to the ozone layer and weak greenhouse effect. Its GWP is 675. Because of its thermodynamic characteristics, R32 requires a smaller charging quantity to reach high energy efficiency. It is inflammable and odourless, but may cause explosion under certain circumstances.

CONTENTS

1. SAFETY NOTICE ON MAINTENANCE	1
2. SAFETY NOTICE ON OPERATION	2
1. PRODUCT INTRODUCTION	3
1.1 Lists of Units	3
1.1.1 List of ODUs	3
1.1.2 List of IDUs	4
1.2 Electrical Parameters	8
2. CONTROL	9
2.1 Operation Mode	9
2.1.1 Cooling Mode	9
2.1.2 Heating Mode	10
2.2 Control Mode	10
2.2.1 Based Control.....	10
2.2.2 Special Control.....	11
2.2.3 Protection Control.....	12
2.3 Functions	12
2.3.1 Setting of Filter Cleaning Reminder	12
2.3.2 Low-temperature Drying Function.....	13
2.3.3 Child-lock Function.....	13
2.3.4 Memory Function	13
2.3.5 Door Control Function.....	13
2.3.6 Switch between Fahrenheit and Degree Celsius.....	14
2.3.7 Inquiry of Ambient Temperature.....	14
2.3.8 Inquiry of Historical Malfunction.....	14
2.3.9 Debugging Function	14
2.3.10 Connect to Interface of Centralized Control	17
3. TROUBLESHOOTING	19
3.1 Wiring Diagrams	19
3.1.1 Wiring Diagrams of ODUs	19
3.1.2 Wiring Diagrams of IDUs	23
3.2 PCB Layout	26
3.2.1 Interface	26
3.2.2 IPM,PFC Testing Method.....	37
3.3 Error Code	39

3.4 Troubleshooting	41
3.4.1 “E1” Compressor High Pressure Protection	41
3.4.2 “E2” Indoor Anti-freezing Protection	42
3.4.3 “E3” Compressor Low-pressure Protection, Refrigerant Shortage Protection, Refrigerant Recovery Mode	43
3.4.4 “E4” Compressor Air Discharge High-temperature Protection	44
3.4.5 “E6” Communication Error	45
3.4.6 “E8” Indoor Fan Error	46
3.4.7 “E9” Water Overflow Protection	47
3.4.8 “F0” Indoor Ambient Temperature Sensor Error	48
3.4.9 “F1” Evaporator Temperature Sensor Error	49
3.4.10 “F2” Condenser Temperature Sensor Error	50
3.4.11 “F3” Outdoor Ambient Temperature Sensor Error	51
3.4.12 “F4” Discharge Temperature Sensor Error	52
3.4.13 “F5” Wired Control Temperature Sensor Error	53
3.4.14 “C5” IDU Jumper Cap Error	54
3.4.15 “EE” IDU or ODU Memory Chip Error	54
3.4.16 “PF” Electric Box Sensor Error	55
3.4.17 “H3” Compressor Overload Protection	56
3.4.18 “H4” Overload	56
3.4.19 “H5” IPM Protection	57
3.4.20 “H6” DC Fan Error	58
3.4.21 “H7” Driver Out-of-Step Protection	59
3.4.22 “HC” PFC Protection	60
3.4.24 “Lp” IDU and ODU Unmatched	62
3.4.25 “U7” 4–Way Valve Switch-Over Error	63
3.4.26 “P0” Driver Reset Protection	63
3.4.27 “P5” Over-Current Protection	64
3.4.28 “P6” Master Control and Driver Communication Error	65
3.4.29 “P7” Driver Module Sensor Error	66
3.4.30 “P8” Driver Module High Temperature Protection	67
3.4.31 “PA” AC Current Protection	67
3.4.32 “Pc” Driver Current Error	68
3.4.33 “Pd” Sensor Connection Protection	69
3.4.34 “PL” Bus Low-Voltage Protection	69
3.4.35 “PH” Bus High-Voltage Protection	70
3.4.37 “ee” Drive Memory Chip Error	71
3.4.38 “c4” ODU Jumper Cap Error	72
3.4.39 “EL” Emergency Stop (Fire Alarm)	73
3.5 Failures Not Caused by Errors	73
4. MAINTENANCE	75
4.1 System Diagram	75
4.2 Connection Pipe Vacuum Pumping	75
4.3 Refrigerant Charging	76

4.4 Maintenance of Major Components.....	78
4.5 Removal of Major Components.....	78
4.5.1 Removal of ODU Major Components	78
4.5.2 Removal of IDU Major Components	114
4.6 Explosive View and Lists of Parts	125
4.6.1 ODU Explosive View and Lists of Parts.....	125
4.6.2 IDU Explosive View and Lists of Parts.....	146
 APPENDICES.....	 180
1 Resistance/temperature lists of temperature sensors.....	180
1.1 Voltage list of 15 kΩ temperature sensors (including ODU and IDU temperature sensors)	180
1.2 Voltage list of 20 kΩ pipeline temperature sensors (including temperature sensors for defroster, IDU and ODU pipes).....	182
1.3 Voltage list of 50 kΩ discharge temperature sensors (including discharge air temperature sensor)	185
2. Temperature/Pressure List of Refrigerant.....	187
3. Refrigerant Notice/Concentration	188
4. Operation Tools	189

1. Safety Notice on Maintenance



PROHIBITED:

1. Do not pierce or burn.
2. Please note that refrigerant may be odorless.
3. The appliance shall be stored in a room without continuously operating ignition sources (For example: open flames, an operating gas appliance or an operating electric heater).
4. Indoor unit adopts special joints that can't be detached. The installation method is the same with the common joints. However, because the joint can't be detached, if it is badly connected and causes leakage, it needs to be cut and replaced by a new one through welding.
5. Using unsuitable parts or tools may lead to electric shock or fire hazard.
6. If refrigerant leaks during maintenance, please ventilate the room immediately. Heavy leakage may lead to breathing difficulty, severe injury or death.
7. Disconnect power before disassembling the appliance for maintenance.
8. The appliance should be maintained and cared by authorized technical personnel with necessary qualifications.



WARNING:

1. If the working place is more than 2m's high, please wear a safety helmet, gloves and a safety belt.
2. Never mix any other substances except the specified refrigerant into the refrigerant circuit.
3. When re-locating the appliance, check whether the new location is strong enough to withstand the weight of the appliance.
4. If there is refrigerant leak, please fix the leak before charging in the refrigerant. After refrigerant is charged, check for refrigerant leaks. If you cannot spot the leak, stop the maintenance work. Please evacuate the system and close the service valve to prevent refrigerant leaking into the room.
5. Prepare suitable tools and protectors.
6. If you need to carry out maintenance or check the electric circuit without cutting off the power, please be careful not to touch the electrical parts.



NOTICE:

1. If the appliance is maintained at a humid place, it should be grounded to avoid electric shock.
2. Never repair the unit with wet hands. Operating the unit with wet hands may lead to electric shock.
3. If the unit is not correctly grounded, please check and fix it.
4. Before cleaning the unit, please disconnect power to prevent the inner fan from starting up and running at high speed; otherwise personal injury may occur.
5. Measure the insulation resistance after maintenance. The resistance must be 1M or higher. Bad insulation may lead to electric shock.
6. Welding and cutting work must be done in a well-ventilated place.
7. Gas appliances, heaters and other fire sources should be kept away from the installation and maintenance site.
8. Maintenance should be done according to suggestions of the manufacturer.
9. Maintenance should be done only after the refrigerant is completely reclaimed from the unit.

**OBSERVED:**

1. After the maintenance work is done, check the drainage of indoor unit.
2. Do not tilt the unit, otherwise, water may spill out from the unit and make the floor and furniture wet.
3. Disassembly of the unit, handling of the refrigerant, oil and accessories should all be done according to applicable local rules and regulations.

2. Safety Notice on Operation

**PROHIBITED:**

1. Never try to modify the unit, otherwise, it may cause electric shock, overheat or fire hazard.
2. If the power cord or conducting wires are scratched, please replace them.
3. Never use connected or extended power cord or share the power socket with other appliances.
4. Prepare a specialized power circuit for the appliance.

**WARNING:**

1. If the power plug is dirty, please clean it before inserting it to the power socket. If the power plug is loose, please tighten it up.
2. Do not damage the power cord. A damaged or refitted power cord may lead to electric shock or fire hazard.
3. Check frequently whether the appliance is in good condition.

**NOTICE:**

1. After changing the batteries of remote control, please discard them to avoid being swallowed by children.
2. When the unit is working, do not remove the fan cover.
3. Do not use organic solvents to wipe the controller operating panel.
4. Before cleaning the unit, cut off the power supply.

1. Product Introduction

1.1 Lists of Units

1.1.1 List of ODUs





Model	Power Supply	Finished Product Code	Appearance	
	V/Ph/Hz			
GUD35W/NhA-T	220-240V 1N~50Hz 208-230V 1N~60Hz	CF090W1310		
GUD50W/NhA-T		CF090W1210		
GUD71W/NhA-T		CF090W1220		
GUD85W/NhA-T		CF090W1230		
GUD100W/NhA-T		CF090W1240		
GUD125W/NhA-T		CF090W1260		
GUD140W/NhA-T		CF090W1280		
GUD100W/NhA-X		380-415V 3N~50Hz/60Hz	CF090W1250	
GUD125W/NhA-X			CF090W1270	
GUD140W/NhA-X			CF090W1290	
GUD160W/NhA-X	380-415V 3N~50Hz/60Hz	CF090W1300		

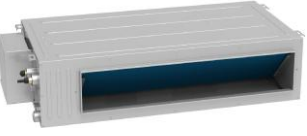
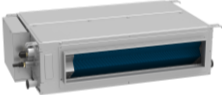

Note: 1 Ton =12000Btu/h = 3.517kW

If one outdoor unit is to be connected with multiple indoor units, the indoor units must have the same cooling capacity and be of the same type.

1.1.2 List of IDUs

Model		Rated Cooling/ Heating Capacity (kw)	Power Supply	Finished Product Code	Appearance
			V/Ph/Hz		
Cassette Type	GUD35T/A-T	-	220-240V 1N~50Hz 208-230V 1N~60Hz	-	
	GUD50T/A-T	5.0/5.5		ET010N1540	
	GUD71T/A-T	7.0/8.0		ET010N1420	
	GUD85T/A-T	8.5/8.8		ET010N1430	
	GUD100T/A-T	10.0/12.0		ET010N1440	
	GUD125T/A-T	12.1/13.5		ET010N1450	
	GUD140T/A-T	13.4/15.5		ET010N1460	
	GUD160T/A-T	14.5/17.0		ET010N1470	
Duct Type	GUD35P/A-T	3.5/4.0	220-240V 1N~50Hz 208-230V 1N~60Hz	CF022N1650	
	GUD50P/A-T	5.0/5.5		CF022N1630	
	GUD71P/A-T	7.0/8.0		CF022N1620	
	GUD85P/A-T	8.5/8.8		CF022N1610	

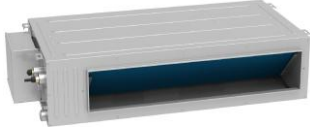
Model		Rated Cooling/ Heating Capacity (kw)	Power Supply	Finished Product Code	Appearance
			V/Ph/Hz		
Duct Type	GUD100PH/A-T	10.0/12.0	220-240V 1N~50Hz 208-230V 1N~60Hz	CF022N1590	
	GUD125PH/A-T	12.1/13.5		CF022N1570	
	GUD140PH/A-T	13.4/15.5		CF022N1550	
	GUD160PH/A-T	16.0/17.0		CF022N1530	
	GUD35PS/A-T	3.5/4.0		CF022N1640	
	GUD50PS/A-T	5.0/5.5		CF022N1620	
	GUD71PS/A-T	7.0/8.0		CF022N1660	
	GUD85PS/A-T	8.5/8.8		CF022N1600	
	GUD100PHS/A-T	10.0/12.0		CF022N1580	

Model		Rated Cooling/ Heating Capacity (kw)	Power Supply	Finished Product Code	Appearance
			V/Ph/Hz		
Duct Type	GUD125PHS/A -T	12.1/13.5	220-240V 1N~50Hz 208-230V 1N~60Hz	CF022N1560	
	GUD140PHS/A -T	13.4/15.5		CF022N1540	
	GUD160PHS/A -T	16.0/17.0		CF022N1520	
Floor Ceiling Type	GUD35ZD/A-T	3.5/4.0	220-240V 1N~50Hz 208-230V 1N~60Hz	ED020N1720	
	GUD50ZD/A-T	5.0/5.5		ED020N1730	
	GUD71ZD/A-T	7.0/8.0		ED020N1740	
	GUD85ZD/A-T	8.5/8.8		ED020N1750	
	GUD100ZD/A-T	10.0/12.0		ED020N1680	

Model		Rated Cooling/ Heating Capacity (kw)	Power Supply	Finished Product Code	Appearance
			V/Ph/Hz		
Floor Ceiling Type	GUD125ZD/A-T	12.1/13.5	220-240V 1N~50Hz 208-230V 1N~60Hz	ED020N1690	
	GUD140ZD/A-T	13.4/15.5		ED020N1700	
	GUD160ZD/A-T	16.0/17.0		ED020N1710	

Note: The outdoor unit is generally suitable to any one of the three types of indoor units with no need of change (limited to cassette type, duct type and floor ceiling type).

1.2 Electrical Parameters

Model	Power supply	Circuit breaker capacity	Min. sectional area of power cord
	V/Ph/Hz	A	mm ²
GUD35W/NhA-T	220-240V 1N~50Hz 208-230V 1N~60Hz	16	1.5
GUD50W/NhA-T		16	1.5
GUD71W/NhA-T		20	2.5
GUD85W/NhA-T		25	2.5
GUD100W/NhA-T		32	4.0
GUD125W/NhA-T		32	4.0
GUD140W/NhA-T		40	6.0
GUD100W/NhA-X	380-415V 3N~50Hz/60Hz	16	1.5
GUD125W/NhA-X		16	1.5
GUD140W/NhA-X		16	1.5
GUD160W/NhA-X		16	1.5

Model	Power Supply	Fuse Capacity	Circuit Breaker Capacity	Min. Sectional Area of Power Cord
	V/Ph/Hz	A	A	mm ²
Indoor unit	220-240V 1N~50Hz 208-230V 1N~60Hz	3.15	6	1.0



NOTICE:

- ① Fuse is located on the main board.
- ② Install a circuit breaker at every power terminal near the units (indoor and outdoor units) with at least 3mm contact gap. The units must be able to be plugged or unplugged.
- ③ Circuit breaker and power cord specifications listed in the above table are determined based on the maximum power input of the units.
- ④ Specifications of power cords listed in the above table are applicable in a working condition where ambient temperature is 40°C and multi-core copper cable (e.g. YJV copper cable, with insulated PE and PVC sheath) is protected by a conduit, and is resistant to 90°C in maximum (See IEC 60364-5-52). If working condition changes, please adjust the specifications according to national standards.
- ⑤ Specifications of circuit breaker are based on a working condition where the working temperature is 40°C. If working condition changes, please adjust the specifications according to national standards.
- ⑥ Adopt 2pc of 0.75mm² power cords to be the communication cords between indoor and outdoor units. The maximum length is 100m. Please select a proper length according to local conditions. Communication cords must not be twisted together. To be in compliance with EN 55014, it is necessary to use 8 meters long wire.
- ⑦ Adopt 2pc of 0.75mm² power cords to be the communication cords between wired control and indoor unit. The maximum length is 30m. Please select a proper length according to local conditions. Communication cords must not be twisted together. To be in compliance with EN 55014, it is necessary to use 7.5 meters long wire.
- ⑧ The wire gauge of communication cord should not be less than 0.75mm². It's recommended to use 0.75mm² power cords as the communication cords.

2. Control

2.1 Operation Mode

2.1.1 Cooling Mode

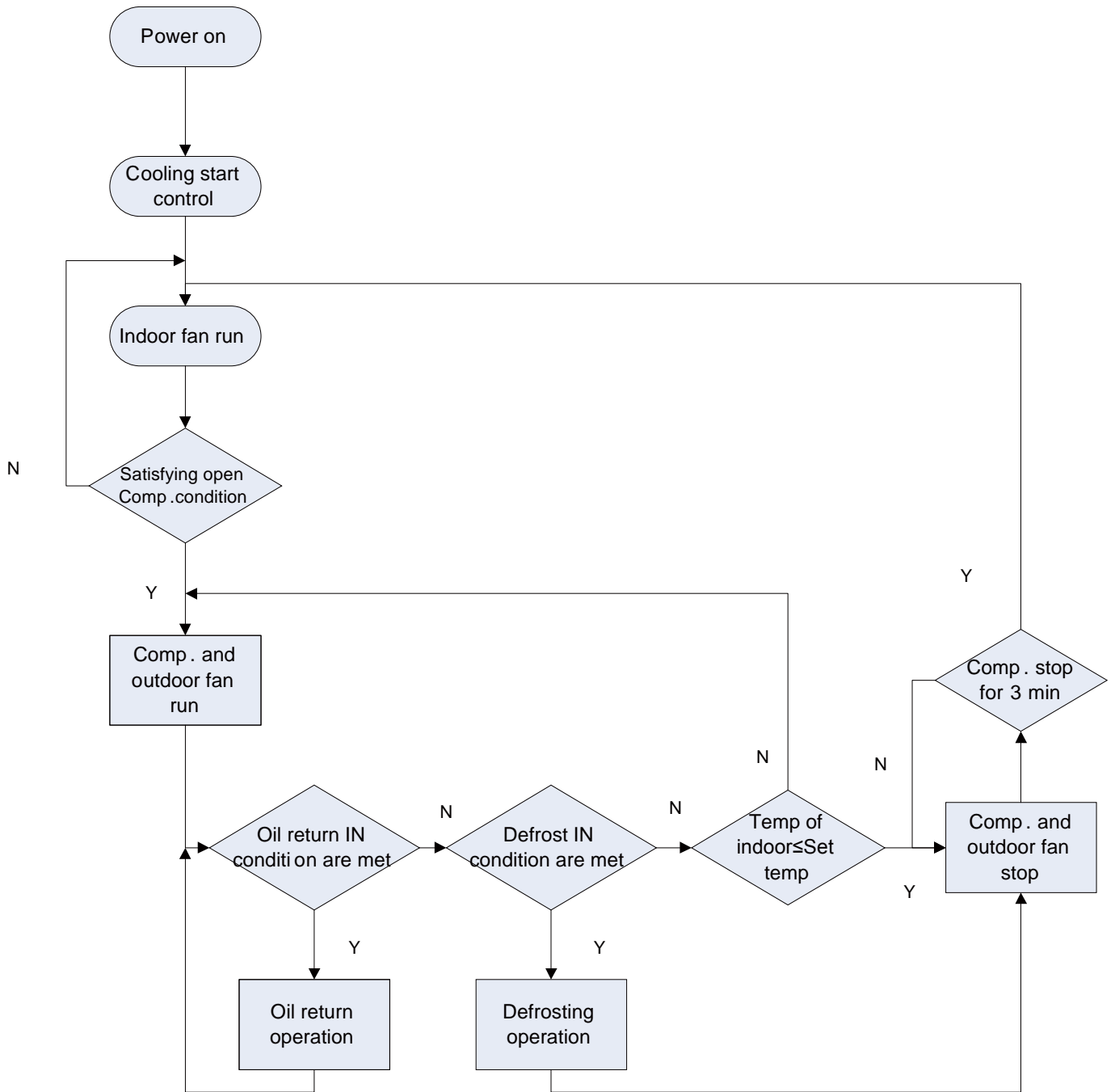

2.1.2 Heating Mode

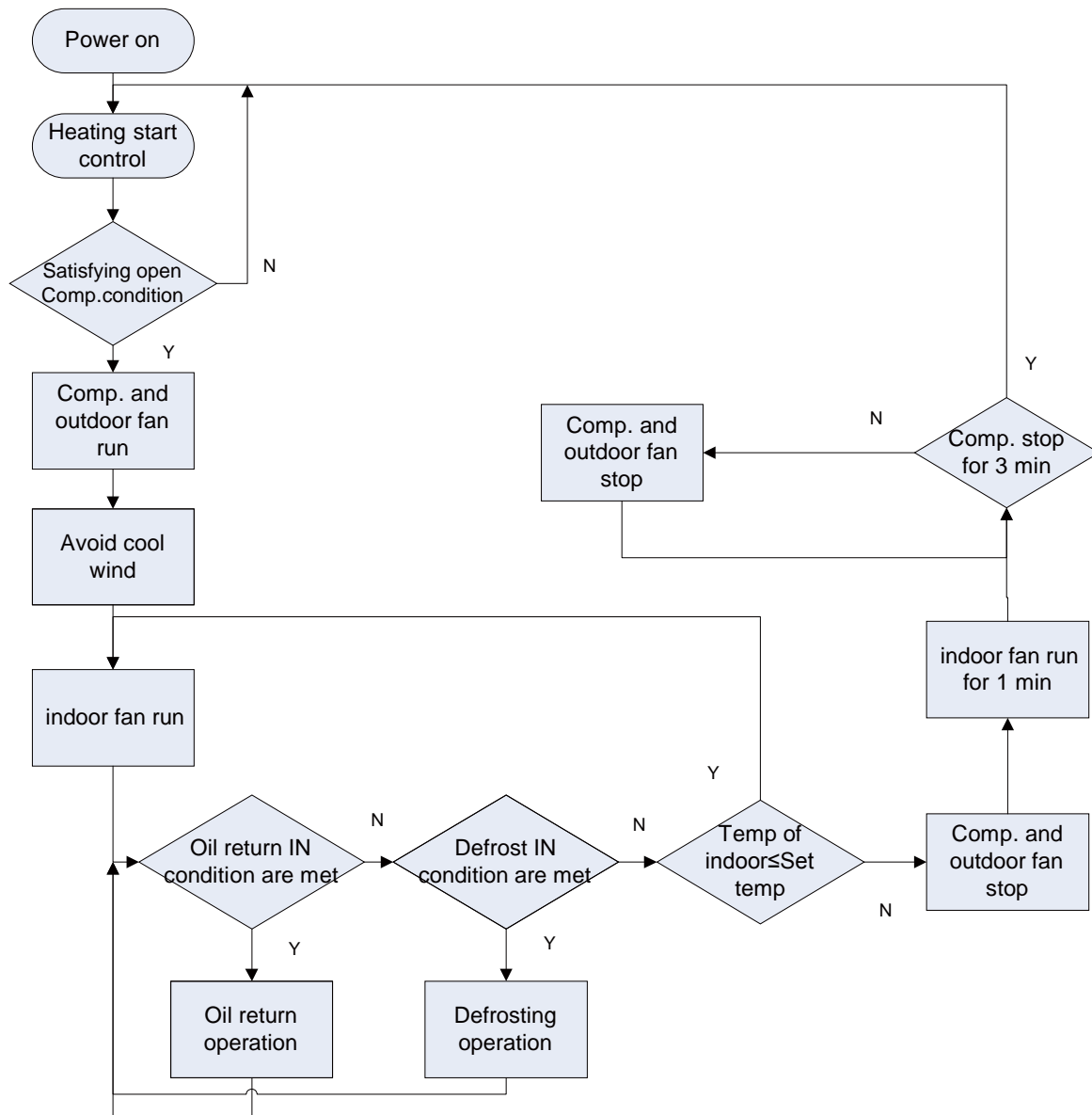

2.2 Control Mode

2.2.1 Based Control

2.2.1.1 Compressor Control

When cooling or heating mode is turned on, indoor fan will run for a while before the compressor starts. Under different modes, the compressor can only be stopped after running for some time (special cases excluded). This is to protect the compressor from frequent start or stop. Once the compressor is stopped, it must not be restarted right away. Please wait for a few minutes.

2.2.1.2 EXV Control

When the unit is first started, the electronic expansion valve will reset control. During the process, the expansion valve will produce rattling sound. When cooling or heating mode is turned on, the valve will be open at a certain step before the compressor starts.

2.2.1.3 Outdoor Fan Control

This series air conditioner has two types of outdoor units: one with a single fan and the other with double fans. The outdoor fan can run at the highest level 10 and the lowest level 1. By controlling the speed of outdoor fan, the unit can achieve cooling at low temperature and heating at high temperature. In fan mode, outdoor fan will not work.

2.2.1.4 4-way Valve Control

After heating mode is turned on for a while, 4-way valve will be energized to change the direction of refrigerant flow so that the system can run in heating and the indoor unit will not blow cold air. Under other modes, the valve will not be energized.

To avoid the 4-way valve from incorrectly changing directions, when the unit stops in heating, due to a temperature point or other protection reasons, the 4-way valve will continue to function temporarily and lose power after a while.

There must be adequate differential pressure for the 4-way valve to change directions.

2.2.2 Special Control

2.2.2.1 Defrosting Control

ODU defrosting control in heating: Defrosting will start when the temperature sensed by outdoor tube temperature sensor reaches a preset value. During defrosting, the 4-way valve will switch to the cooling condition, and outdoor and indoor fans will both stop. When the temperature sensed by outdoor tube temperature sensor reaches the preset value of defrosting stop, system will quit defrosting. The 4-way valve will switch back to the heating condition, outdoor fan will start working first and indoor fan will resume its previous fan speed after performing cold air prevention.

2.2.2.2 Oil Return Control

If the unit is running at low frequency for a long time, system will enable oil return control. This is to lead oil in the pipeline back to the compressor so that the compressor will not be lack of oil. Generally, the oil return takes about 5min. The compressor running frequency will be raised to the preset oil return frequency.

2.2.2.3 Refrigerant Recovery Control

Enabling method: Remote control and wired control both use the same enabling method. That is, within 5min after power is connected, start cooling mode (turn on the unit) and set temperature at 16°C, then press “▲, ▼, ▲, ▼, ▲, ▼” (6 times of pressing) in 5s to enter the refrigerant recovery mode. If it is successfully enabled, the indoor unit will display the corresponding code E3.

After the refrigerant recovery mode is enabled, if remote control or wired control sends a signal or the refrigerant recovery mode has been enabled for 10min, system will exit from refrigerant recovery. If outdoor unit is shut down because of malfunction, refrigerant recovery will be stopped immediately.

Please note that refrigerant recovery mode cannot be enabled under the following conditions:

1. If temperature is shielded remotely, refrigerant recovery mode cannot be enabled. You need to first unlock the remote shield against temperature.
2. If temperature is higher than 16 degrees under energy-saving mode, refrigerant recovery mode cannot be enabled. You need to first turn off the energy-saving mode.

2.2.2.4 Forced Operation Control

This control is used to quickly check whether the unit can operate normally after installation. Wired control has to be used to enable this control. For cassette type unit, you can enable the control through the light board.

Enabling method through the light board of cassette type unit: After the unit is installed and connected to power, press TEST button on the light board to enter forced operation mode. Short-press TEST button (less than 2s), cooling mode will be activated. Long-press TEST button (more than 2s), heating mode will be activated.

Enabling method through wired control:

Under power-on status,

Forced cooling: press the “▼” button continuously for 5s to enter the forced test mode;

Forced heating: press the “▲” button continuously for 5s to enter the forced test mode.

During test mode, press any button to quit the test mode.

Note: Forced test mode can only be enabled when the unit is first turned on and not yet receives any remote control signal or button control signal.

2.2.3 Protection Control

2.2.3.1 High Pressure Protection Control

System will enable high pressure protection control if the high pressure switch is detected open for continuously a little time. Under high pressure protection, system will be shut down and display error code E1.

When high pressure protection occurs for the first time, system will restore operation if the high pressure switch is detected to be reclosed for continuously a little time. When high pressure protection occurs for the second time in a certain time period, system will not restore operation. You need to manually turn off the unit and clear the error before restarting up the unit. (If high pressure protection occurs frequently, please send for professional personnel to repair.)

2.2.3.2 Low Pressure Protection Control

System will enable low pressure protection control if the low pressure switch is detected open for continuously a little time. Under low pressure protection, system will be shut down and display error code E3. When low pressure protection occurs, system will restore operation if the low pressure switch is detected to be reclosed within a few minutes after shutdown. If low pressure protection occurs for several times in a period of time, system will not restore operation automatically. You need to manually turn off the unit before restarting up the unit.

2.2.3.3 High Temperature Prevention Control

Under heating mode, system will enable high temperature prevention control if the temperature sensed by indoor tube temperature sensor reaches a certain value. When high temperature prevention control is enabled, outdoor fan will slow down.

2.3 Functions

2.3.1 Setting of Filter Cleaning Reminder

When setting washing remind function, the timer area will display 2 - bit number that means the pollution level, then press “▲” and “▼” buttons to select, and press “SWING/ENTER” button to confirm the setting. Conversion relation between the displayed pollution level and accumulative operating time are as the following list. After setting, when it reaches the washing time, “CLEAN” icon will flash and remind, if you press “▲” and “▼” buttons to adjust the level, and press “SWING/ENTER” button, then the accumulative time for filter washing remind will not be reset; if the time after adjustment is larger than the current accumulative time, then “CLEAN” icon will stop flashing; if the time after adjustment is less than the current accumulative time, then “CLEAN” icon will continue to flash.

The only method for cancelling the remind function is to press “FUNCTION” button to switch to “CLEAN” icon, and set the timer area to be “00”, and then press “SWING/ENTER” button, then the accumulative time of filter washing remind is reset.

Pollution Level	Accumulated Operating Time (hour)	Pollution Level	Accumulated Operating Time (hour)	Pollution Level	Accumulated Operating Time (hour)
10	5500	20	1400	30	100
11	6000	21	1800	31	200
12	6500	22	2200	32	300
13	7000	23	2600	33	400

Pollution Level	Accumulated Operating Time (hour)	Pollution Level	Accumulated Operating Time (hour)	Pollution Level	Accumulated Operating Time (hour)
14	7500	24	3000	34	500
15	8000	25	3400	35	600
16	8500	26	3800	36	700
17	9000	27	4200	37	800
18	9500	28	4600	38	900
19	10000	29	5000	39	1000

2.3.2 Low-temperature Drying Function

Under dry mode, when the setting temperature is 16° C, press “▼” button for twice, the setting temperature becomes 12° C, then the unit enters into low-temperature dry function.

When low-temperature dry function is turned on, directly press “▲” button or switch the mode can quit the function.

2.3.3 Child-lock Function

Without error, under ON or OFF status of unit, press “▲” and “▼” buttons simultaneously for 5 seconds can enter into child-lock function, the liquid crystal screen will display “”; press “▲” and “▼” buttons simultaneously again for 5 seconds can quit the child-lock function.

Under child-lock status, no response for pressing any buttons. The unit will memorize the child-lock status after power failure and re-energizing the unit.

2.3.4 Memory Function

Under power-off status, press “MODE” and “▲” button simultaneously for 5 seconds can turn on or turn off memory function. When memory function is set, “MEMORY” displays.

If memory function has not been set, when the unit is re-energized after power failure, the unit is power-off status. If the memory function is set in wired controller, when the wired controller is re-energized after power failure, it will resume to the operating status before power failure.

2.3.5 Door Control Function

When door control function is selected, the wired control will work when the room card is inserted and stop working when the room card is pulled out. When door control function senses the room card is not inserted.

The setting method please refer to Debugging Function (2.3.9).

Note:

- ① . In long-distance monitoring or centralized control, no matter the room card is inserted or not, the ON/OFF of unit can be controlled. If long-distance monitoring or centralized control information is received when the room card is not inserted. When the card is reinserted, door control function is judged to be turned on. If long-distance monitoring or centralized control information is received when the room card is inserted, it will keep the original status.
- ②. The unit can not be controlled by buttons when the card is not inserted.

2.3.6 Switch between Fahrenheit and Degree Celsius

Under power-off status, press “MODE” and “▼” buttons simultaneously for 5 seconds, display board will switch between degree Celsius and Fahrenheit.

2.3.7 Inquiry of Ambient Temperature

Under power-off or power-on status, press and hold “SWING/ENTER” button for 5 seconds to enter into ambient temperature inquiry interface, then timer area displays the ambient temperature type 01 or 02, and ambient temperature area displays the corresponding ambient temperature of corresponding type. In which, 01 refers to outdoor ambient temperature, 02 refers to indoor ambient temperature. Press “MODE” button can switch between type 01 and 02. Press buttons other than “MODE” or when the unit receives remote control signal, it will quit the inquiry status. If there is no any operation for 20 seconds, it will quit automatically.

Note:

When the outdoor ambient temperature sensor detects the same temperature for 12 hours, it will shield the display of outdoor ambient temperature sensor.

2.3.8 Inquiry of Historical Malfunction

Under off or on state of the unit, continuously press Function and ▼ buttons for 5s to view historical malfunction.

In enquiry state, set temperature displaying zone displays “00”. Press ▲ and ▼ buttons to view the 5 malfunctions happened recently. The timer displaying position displays the specific error code. The 5th displayed malfunction is the last malfunction.

2.3.9 Debugging Function

Under off state of the unit, press Function and Timer buttons at the same time for 5s to go to the debugging menu. Press Mode button to adjust the setting items and press ▲ or ▼ button to set the actual value.

2.3.9.1 Setting ambient temperature sensor (dual ambient temperature sensors function)

Under debugging state, press Mode button to adjust to “00” in temperature displaying zone. Timer zone displays setting state and press ▲ or ▼ button to adjust. There are 3 selections:

- (1) The ambient temperature at air return is set as indoor ambient temperature (timer zone displays 01)
- (2) The temperature at wired controller is set as indoor ambient temperature (timer zone displays 02)
- (3) Select the temperature sensor at air return in cooling, dry and fan mode; select the temperature sensor at wired controller in heating and auto mode.

2.3.9.2 Displaying setting of freeze protection error code

Under debugging state, press Mode button to adjust to “02” in temperature displaying zone. Timer zone displays setting state and press ▲ or ▼ button to adjust. There are 2 selections:

- (1) Displayed (LCD displays 01)
- (2) Not displayed (LCD displays 02)

It is defaulted to be not displayed for export unit and be displayed for domestic unit.

2.3.9.3 Setting refrigerant lacking protection function

Under debugging state, press Mode button to adjust to “04” in temperature displaying zone. Timer zone displays setting

state and press ▲ or ▼ button to adjust. There are 2 selections:

- (1) With refrigerant lacking protection function (LCD displays 01)
- (2) Without refrigerant lacking protection function (LCD displays 02)

2.3.9.4 Selecting blowing residual heating of indoor unit

Under debugging state, press Mode button to adjust to “05” in temperature displaying zone. Timer zone displays setting state and press ▲ or ▼ button to adjust. There are 2 selections:

- (1) Mode 1 (LCD displays 00)
- (2) Mode 2 (LCD displays 01)

Note: Blowing residual heating of indoor unit

Mode 1: Unit stops when reaching temperature point and indoor fan motor does not stop in cooling mode; after unit stops when reaching temperature point in heating mode, duct type unit and floor ceiling unit blow residual heat for 60s and then stop indoor unit, while cassette type unit always operates in low fan speed and blows residual heat for 60s when there is malfunction.

Mode 2: After unit stops when reaching temperature point, the indoor fan motor stops operation with a 10s-delay no matter in cooling mode or in heating mode.

2.3.9.5 Mode selecting of compressor electric heating belt

Under debugging state, press Mode button to adjust to “06” in temperature displaying zone. Timer zone displays setting state and press ▲ or ▼ button to adjust. There are 2 selections:

- (1) Mode 1 (LCD displays 00)
- (2) Mode 2 (LCD displays 01)

Note:

Mode 1: Compressor electric heating belt starts when outdoor ambient temperature is below 35°C and stops when outdoor ambient temperature is above 37°C. When outdoor ambient temperature is within 35°C~ 37°C, the belt will keep its previous operation state.

Mode 2: Compressor electric heating belt starts when outdoor ambient temperature is below -2°C and stops when outdoor ambient temperature is above 0°C. When outdoor ambient temperature is within -2°C~0°C, the belt will keep its previous operation state.

2.3.9.6 Selecting low-power consumption mode

Under debugging state, press Mode button to adjust to “07” in temperature displaying zone. Timer zone displays setting state and press ▲ or ▼ button to adjust. There are 2 selections:

- (1) With low-power consumption mode (LCD displays 00)
- (2) Without low-power consumption mode (LCD displays 01)

2.3.9.7 Selecting door control function

Under debugging state, press Mode button to adjust to “08” in temperature displaying zone. Timer zone displays setting state and press ▲ or ▼ button to adjust. There are 2 selections:

- (1) Without door control function (LCD displays 00)
- (2) With door control function (LCD displays 01)

2.3.9.8 Selecting long-distance monitoring or centralized controller

Under debugging state, press Mode button to adjust to “10” in temperature displaying zone. Timer zone displays setting state and press ▲ or ▼ button to adjust. There are 2 selections:

- (1) Centralized controller (LCD displays 00)
- (2) Long-distance monitoring (LCD displays 01)

2.3.9.9 Selecting fan mode of indoor fan motor

Under debugging state, press Mode button to adjust to “11” in temperature displaying zone. Timer zone displays setting state and press ▲ or ▼ button to adjust.

a. There are 5 selections for low static pressure duct:

- (1) P3 (LCD displays 03)

- (2) P4 (LCD displays 04)
- (3) P5 (LCD displays 05)
- (4) P6 (LCD displays 06)
- (5) P7 (LCD displays 07)

Note: You can select P03, P04, P05, P06, P07 in fan mode of indoor fan motor, which means different fan mode combinations are corresponding to different static pressure. Ex-factory defaulted mode is P05. You can set the mode through wired controller. S01, S02, S03……S12, S13 means the rotation speed of indoor unit is from low to high.

Combination relationship of P03, P04, P05, P06, P07

Static pressure selection	Super high speed	High speed	Medium high speed	Medium speed	Medium low speed	Low speed	Quiet R1 speed	Quiet R2 speed	Quiet R3 speed
P03	S09	S08	S07	S06	S05	S04	S03	S02	S01
P04	S10	S09	S08	S07	S06	S05	S04	S03	S02
P05	S11	S10	S09	S08	S07	S06	S05	S04	S03
P06	S12	S11	S10	S09	S08	S07	S06	S05	S04
P07	S13	S12	S11	S10	S09	S08	S07	S06	S05

b. There are 9 selections for high static pressure duct:

- (1) P1 (LCD displays 01)
- (2) P2 (LCD displays 02)
- (3) P3 (LCD displays 03)
- (4) P4 (LCD displays 04)
- (5) P5 (LCD displays 05)
- (6) P6 (LCD displays 06)
- (7) P7 (LCD displays 07)
- (8) P8 (LCD displays 08)
- (9) P9 (LCD displays 09)

Note: You can select P01, P02, P03, P04, P05, P06, P07, P08, P09 in fan mode of indoor fan motor, which means different fan mode combinations are corresponding to different static pressure. Ex-factory defaulted mode is P05. You can set the mode through wired controller. S01, S02, S03……S12, S13 means the rotation speed of indoor unit is from low to high.

Combination relationship of P01, P02, P03, P04, P05, P06, P07, P08, P09

Static pressure selection	Super high speed	High speed	Medium high speed	Medium speed	Medium low speed	Low speed	Quiet R1 speed	Quiet R2 speed	Quiet R3 speed
P1	S05	S03	S02	S02	S01	S01	S01	S01	S01
P2	S06	S04	S03	S03	S02	S02	S02	S02	S02
P3	S07	S05	S04	S04	S03	S03	S03	S03	S03
P4	S08	S06	S05	S05	S04	S04	S04	S04	S04
P5	S09	S07	S06	S06	S05	S05	S05	S05	S05
P6	S10	S08	S07	S07	S06	S06	S06	S06	S06
P7	S11	S09	S08	S08	S07	S07	S07	S07	S07
P8	S12	S10	S09	S09	S08	S08	S08	S08	S08
P9	S13	S11	S10	S10	S09	S09	S09	S09	S09

2.3.9.10 Selecting compensation of temperature sensor at air return

Under debugging state, press Mode button to adjust to “12” in temperature displaying zone. Timer zone displays setting state and press ▲ or ▼ button to adjust. There are 16 selections:

- (1) Compensate 0°C (LCD displays 00)
- (2) Compensate 1°C (LCD displays 01)
- (3) Compensate 2°C (LCD displays 02)
- (4) Compensate 3°C (LCD displays 03)
- (5) Compensate 4°C (LCD displays 04)
- (6) Compensate 5°C (LCD displays 05)
- (7) Compensate 6°C (LCD displays 06)
- (8) Compensate 7°C (LCD displays 07)
- (9) Compensate 8°C (LCD displays 08)
- (10) Compensate 9°C (LCD displays 09)
- (11) Compensate 10°C (LCD displays 10)
- (12) Compensate 11°C (LCD displays 11)
- (13) Compensate 12°C (LCD displays 12)
- (14) Compensate 13°C (LCD displays 13)
- (15) Compensate 14°C (LCD displays 14)
- (16) Compensate 15°C (LCD displays 15)

Note: Indoor ambient temperature compensation can be set through the wired control (E.g.: If 02 is selected, it indicates the compensation temperature is 2°C. If the indoor ambient temperature detected by the temperature sensor at air return is 29°C, the ambient temperature after compensation is $29^{\circ}\text{C}-2^{\circ}\text{C}=27^{\circ}\text{C}$).

After finishing setting, press Enter/Cancel button to save and exit setting. After entering this interface, the system will exit this menu if there is no operation on the button within 20s. Normal off state interface will be displayed and present setting will not be saved.

2.3.10 Connect to Interface of Centralized Control

The indoor unit is with the interface of centralized controller. When centralized controller is connected, centralized control of unit can be realized when the wired controller is not connected;

(1) Interface instruction:

1) The printing of interface on the indoor unit PCB is COM_BMS, before connecting the centralized controller, a gateway model ME50-00/EG(M) is required, The following figure shows an example;

2) Electrical characteristic: none;

3) Working principle: centralized control the communication of indoor mainboard and realize the unit control;

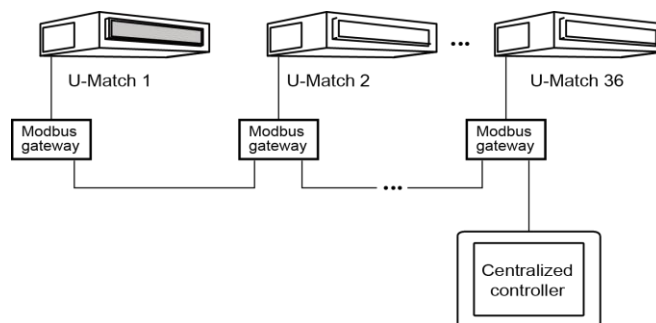

(2) Function instructions:

In order to achieve this function, set the address mode and address through wired controller. Please refer to Point 3 for the setting method. The address mode is defaulted to be connecting to centralized controller mode and the defaulted address is 1;

When the centralized controller is connected, centralized control of the unit can be realized to control unit ON/OFF, operation mode, set fan speed/temperature and weekly timer.

(3) Setting method:

1) Centralized control for up to 16 indoor units.

Firstly, set the address mode of wired controller into centralized controller address mode. The setting method is:

Under off state of the unit, press Function and Timer buttons at the same time for 5s to go to the debugging menu. Press Mode button to adjust to "10" in temperature displaying zone. Timer zone displays setting state and press ▲ or ▼ button to adjust. There are 2 selections:

a. Centralized controller address mode (LCD displays 00)

b. Long-distance control address mode (LCD displays 01)

Choose the first selection and then press Enter/Cancel button to save and exit setting. Now, the address of wired controller is set to match the address of centralized controller. The unit will memorize this setting status. The setting value will be memorized after power failure.

Address setting of each unit: when the address mode is set to be centralized controller address mode. The address setting value range is 01~16. The setting method is:

Under off state of the unit, press Function and Mode buttons at the same time for 5s to enter setting interface of wired controller address. LCD displays address sequence. Press ▲ or ▼ button to adjust the address sequence and then press Enter/Cancel button to confirm. The setting value will be memorized after power failure.

When the address is set, the wired controller can be removed and connect the centralized controller to the indoor mainboard. Then connect the required units to realize centralized control of these units;

Note:

- ① When centralized controller is to be connected, set the address mode into centralized controller address mode through wired controller. Long-distance control address mode can not be set;
- ② The unit addresses in the same network must be different, otherwise, communication malfunction will occur and the unit can not work normally;
- ③ When centralized controller is to be connected, the unit address range is 1-16. Only 16 sets of unit in maximum can be connected
- ④ The code and model of wired controller is as below:

Name	Product code	Remark
Centralized controller CE50-24/E	MC207025	Only 16 sets of unit in maximum can be connected to this controller

2) Centralized control for up to 36 indoor units.

Firstly, set the address mode of wired controller into Long-distance control address mode. The setting method is:

Under off state of the unit, press Function and Timer buttons at the same time for 5s to go to the debugging menu. Press Mode button to adjust to "10" in temperature displaying zone. Timer zone displays setting state and press ▲ or ▼ button to adjust. There are 2 selections:

a. Centralized controller address mode (LCD displays 00)

b. Long-distance control address mode (LCD displays 01)

Choose the second selection and then press Swing/Enter button to save and exit setting. Now, the address of wired controller is set to match the address of centralized controller. The unit will memorize this setting status. The setting value will be memorized after power failure.

Address setting of each unit: when the address mode is set to be Long-distance control address mode. The address setting value range is 01~36. The setting method is:

Under off state of the unit, press Function and Mode buttons at the same time for 5s to enter setting interface of wired controller

address. LCD displays address sequence. Press ▲ or ▼ button to adjust the address sequence and then press Swing/Enter button to confirm. The setting value will be memorized after power failure.

When the address is set, the wired controller can be removed and connect the centralized controller to the indoor mainboard. Then connect the required units to realize centralized control of these units;

Note:

- ① The unit addresses in the same network must be different, otherwise, communication malfunction will occur and the unit can not work normally;
- ② When centralized controller is to be connected, the unit address range is 1-36. Only 36 sets of unit in maximum can be connected
- ③ The code and model of wired controller is as below:

Name	Product code	Remark
Centralized controller CE52-24/F(C)	MC207052	Only 36 sets of unit in maximum can be connected to this controller

3. Troubleshooting

3.1 Wiring Diagrams

3.1.1 Wiring Diagrams of ODUs

Model: GUD35W/NhA-T,

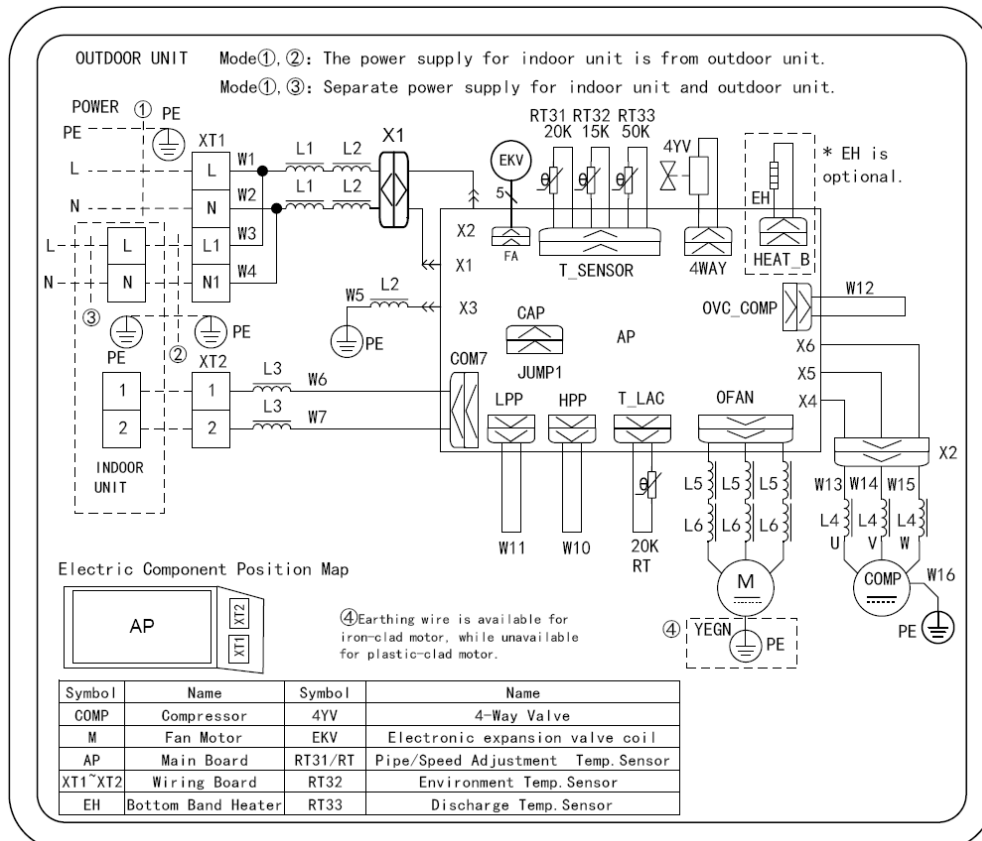

Model: GUD50W/NhA-T

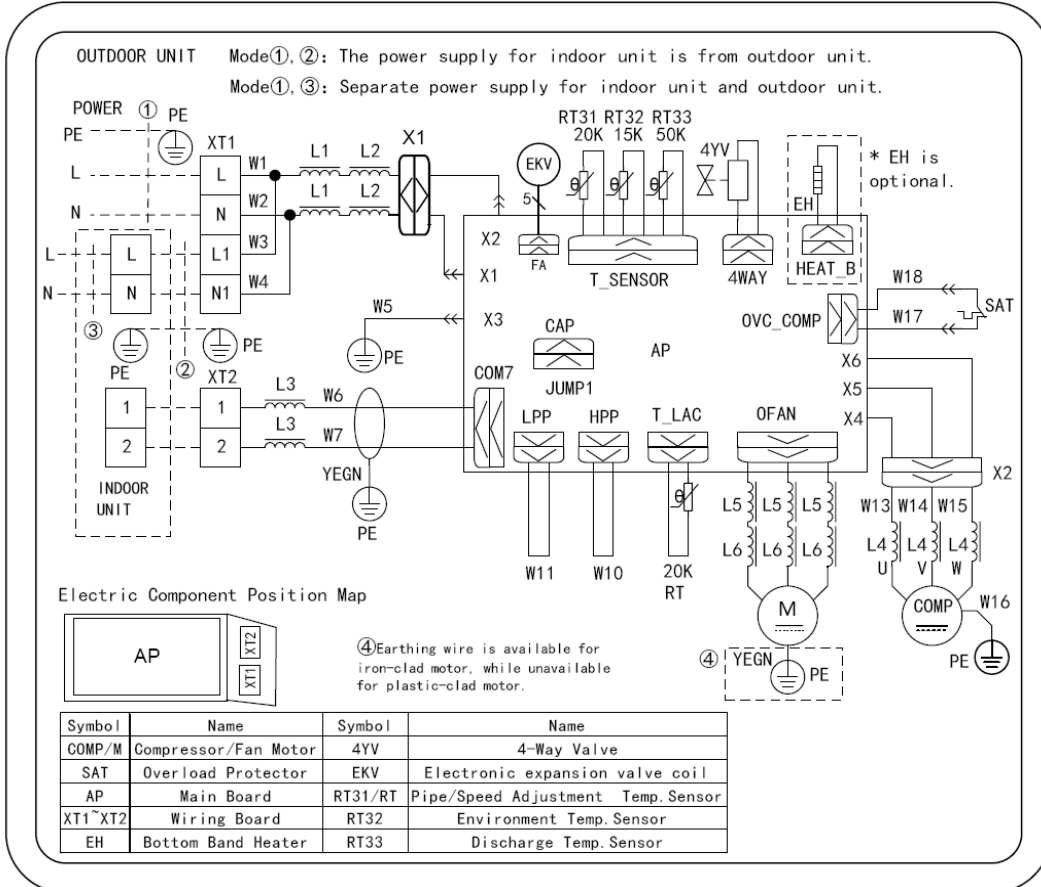

Model: GUD71W/NhA-T, GUD85W/NhA-T

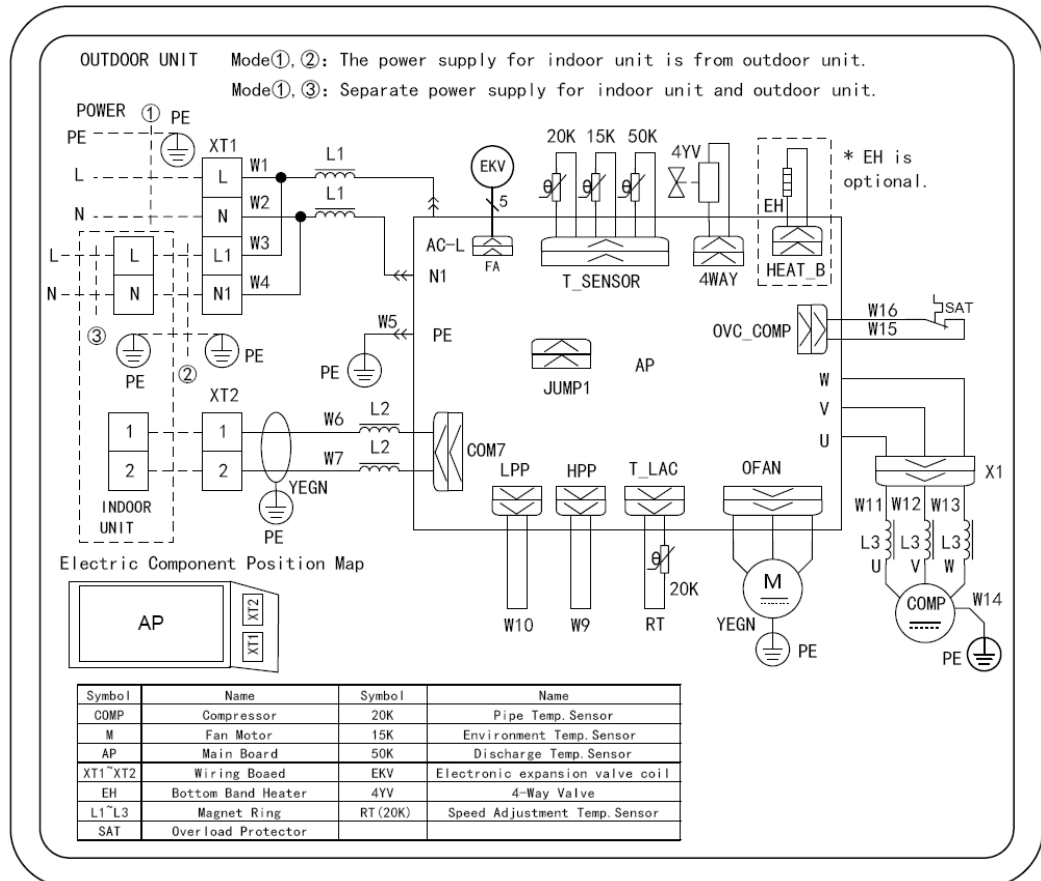

Model:GUD100W/NhA-T

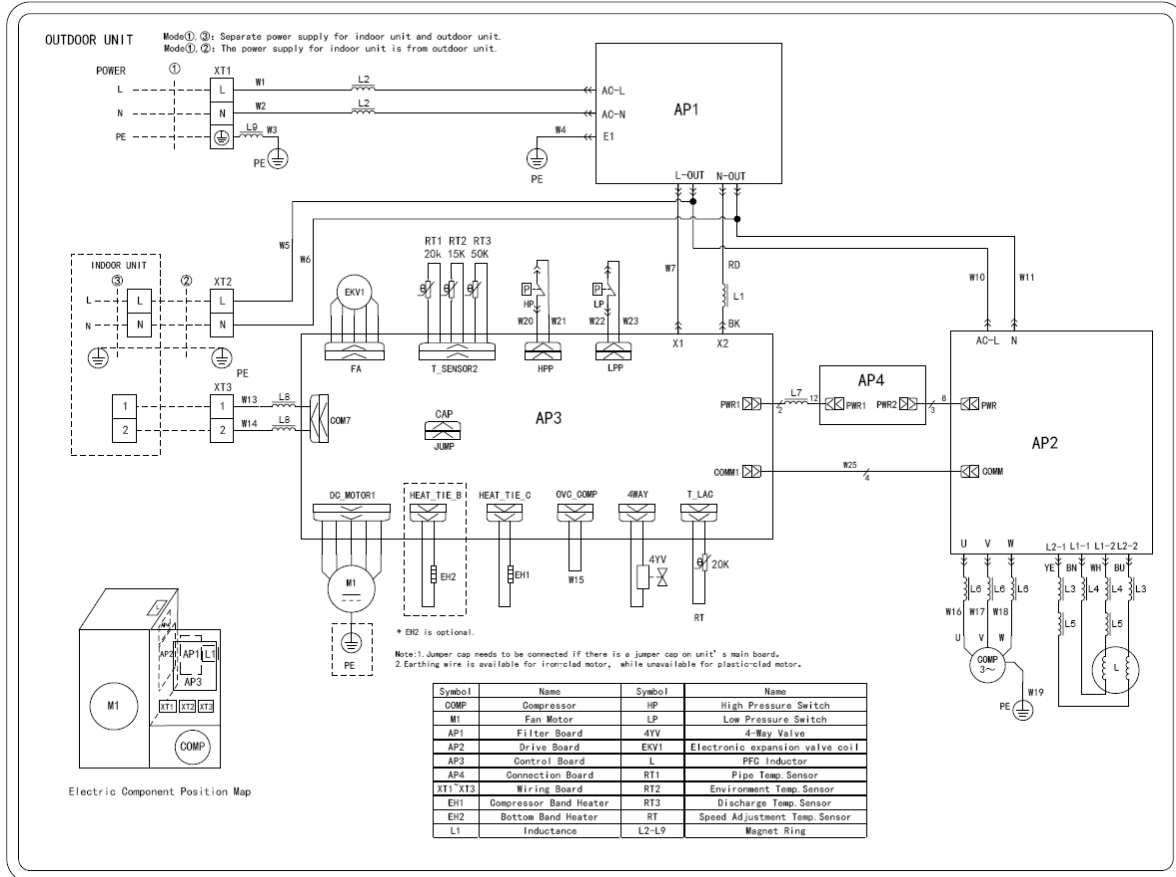

Model:GUD125W/NhA-T, GUD140W/NhA-T

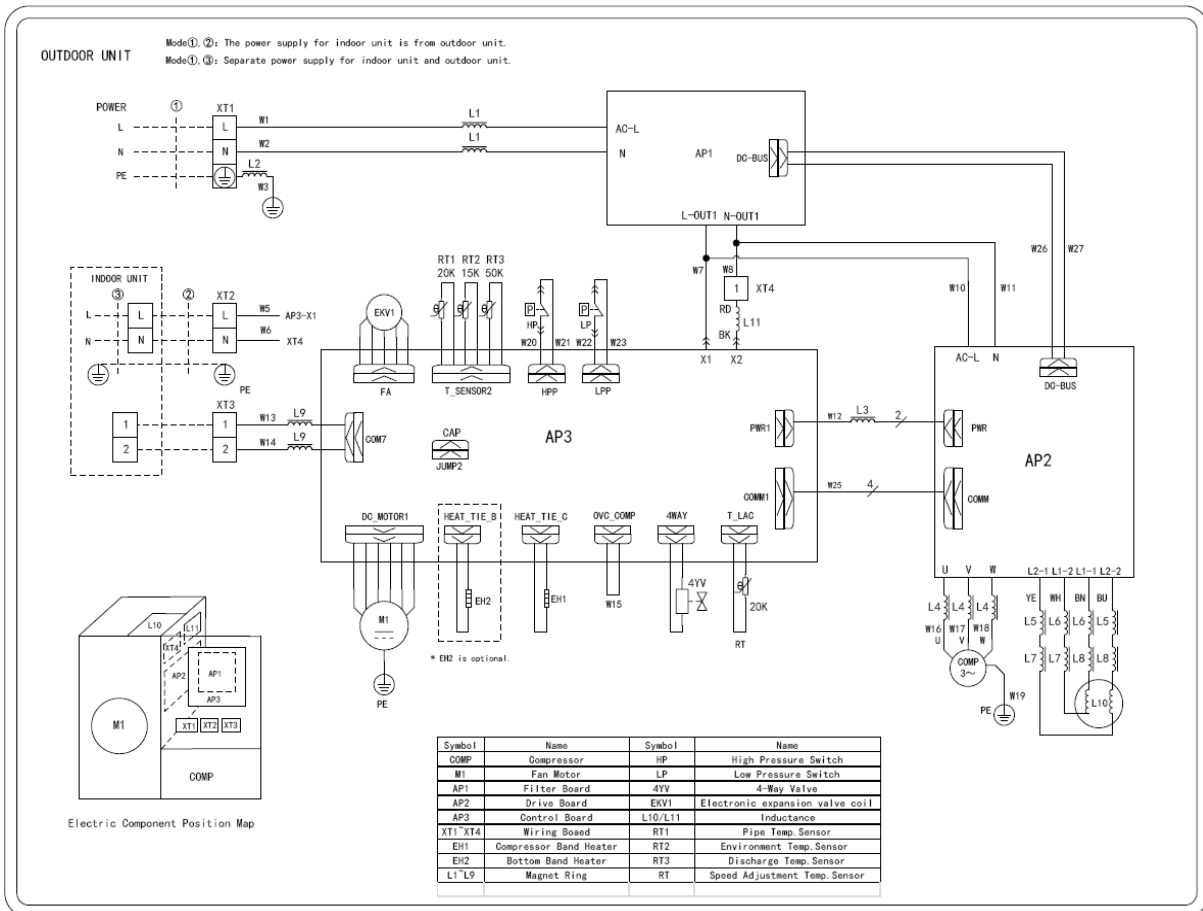

Model:GUD100W/NhA-X

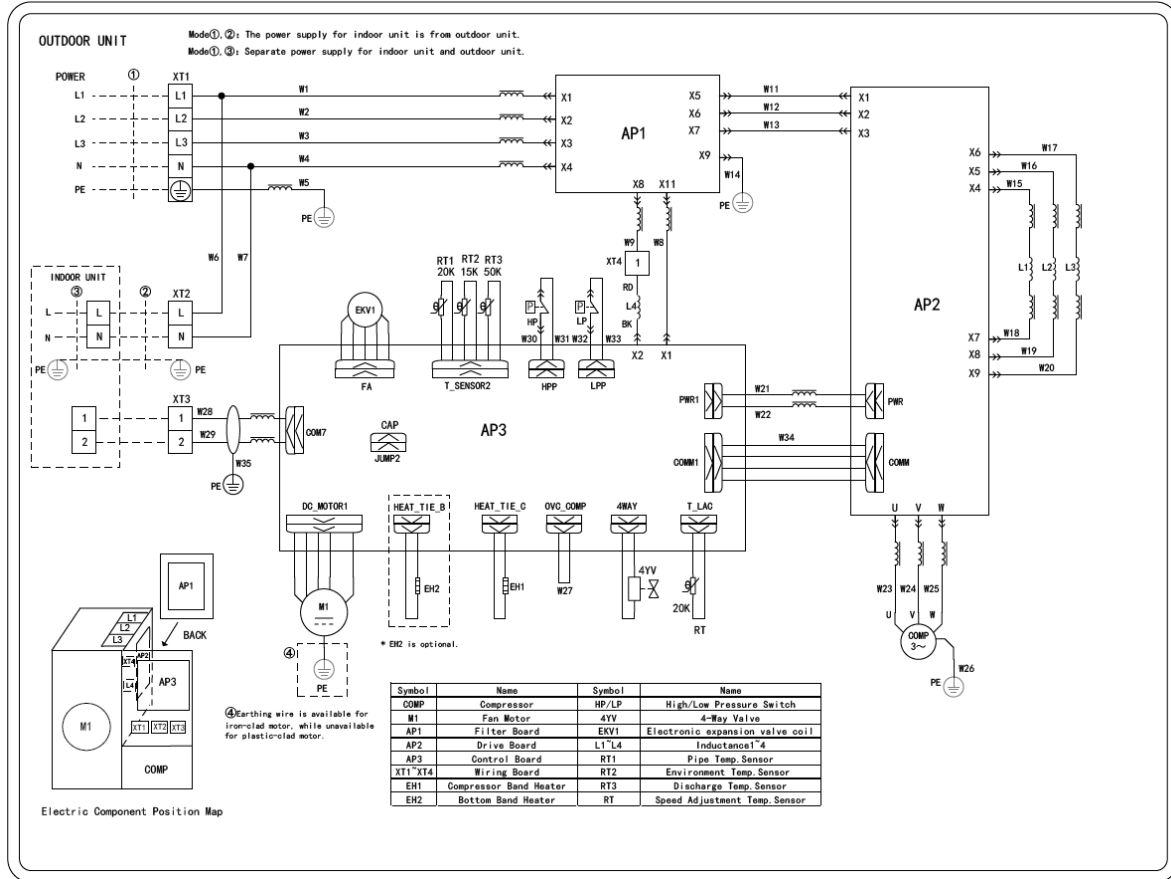

GUD125W/NhA-X,GUD140W/NhA-X

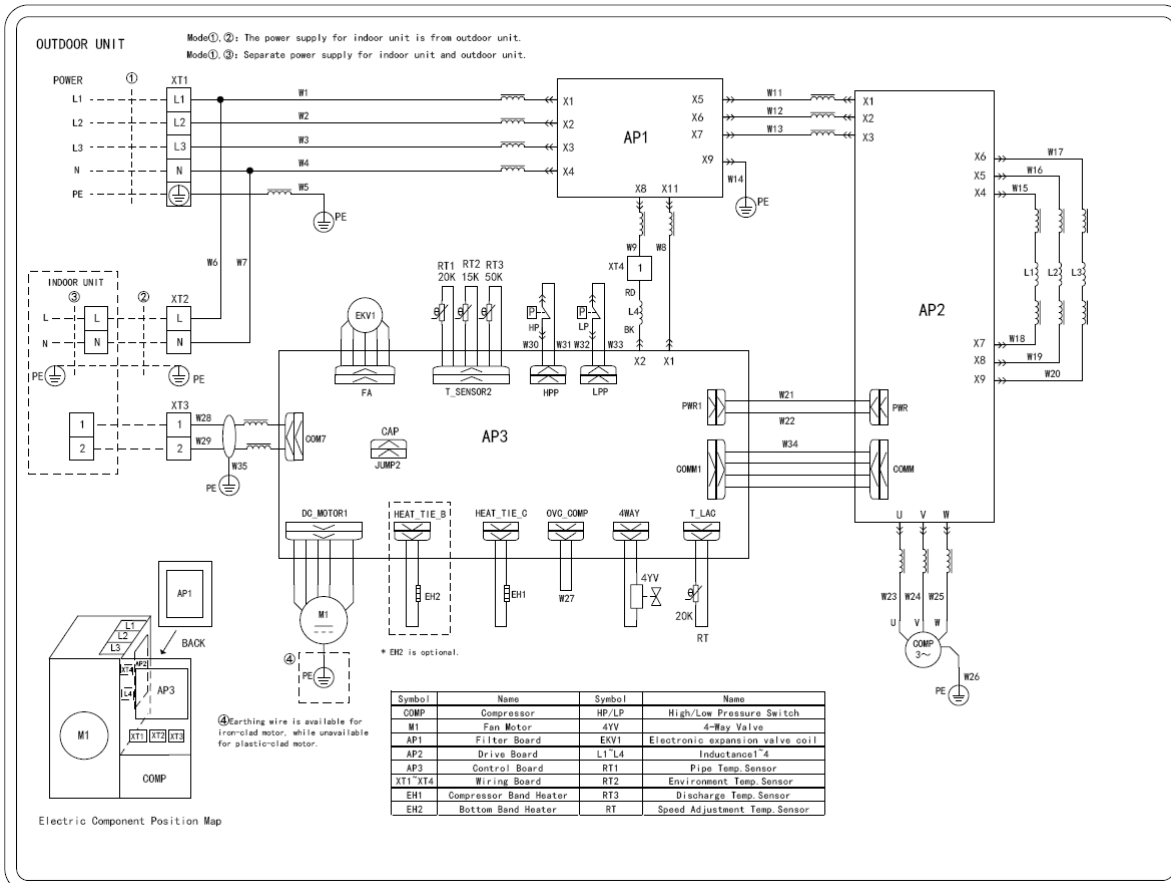

Model:GUD160W/NhA-X

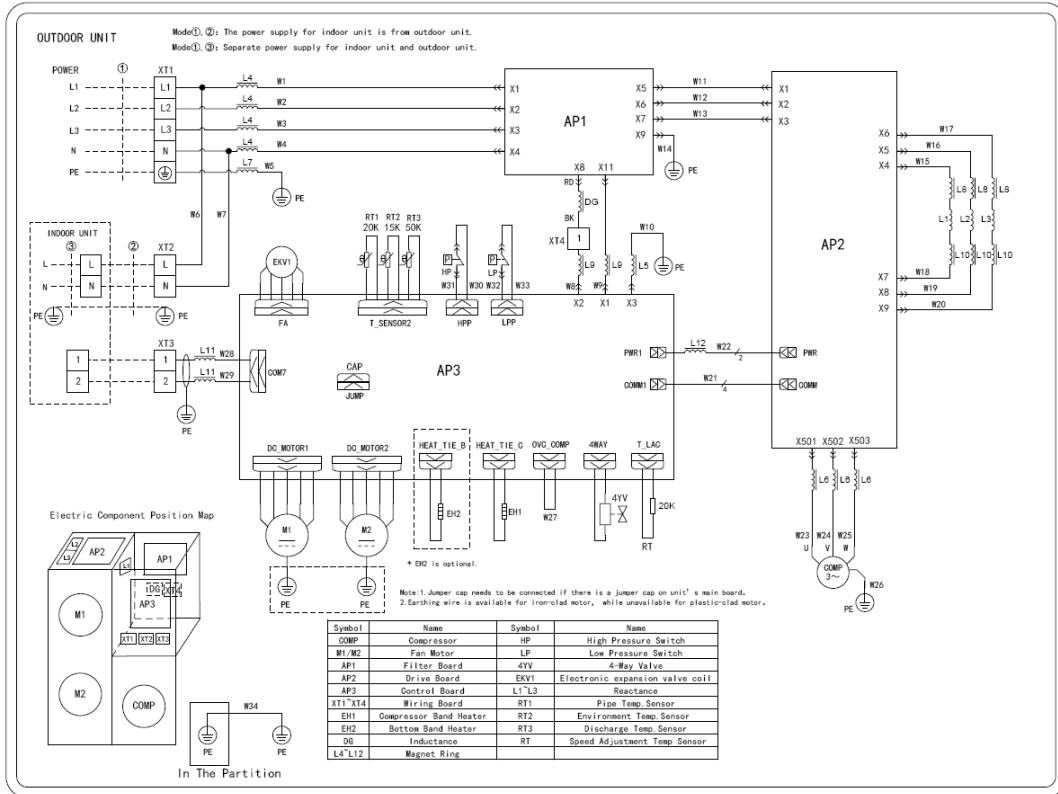

3.1.2 Wiring Diagrams of IDUs

Model: GUD35T/A-T, GUD50T/A-T

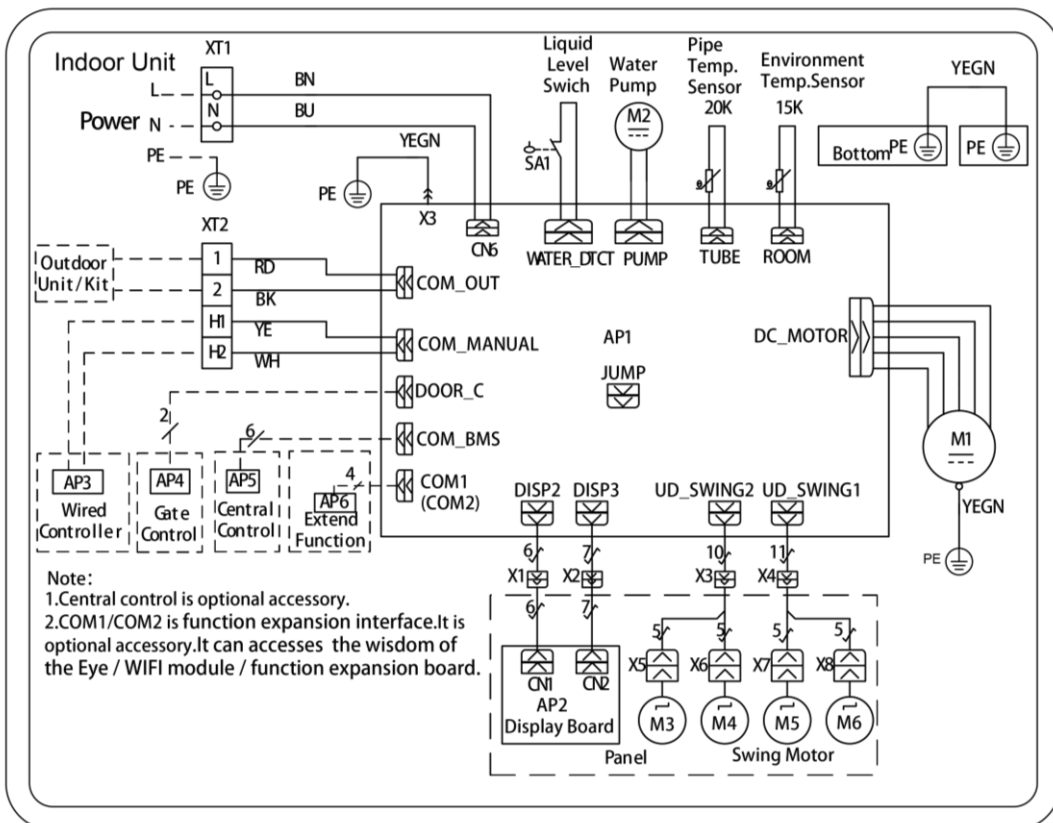

Model: GUD71T/A-T, GUD85T/A-T, GUD100T/A-T, GUD125T/A-T, GUD140T/A-T, GUD160T/A-T

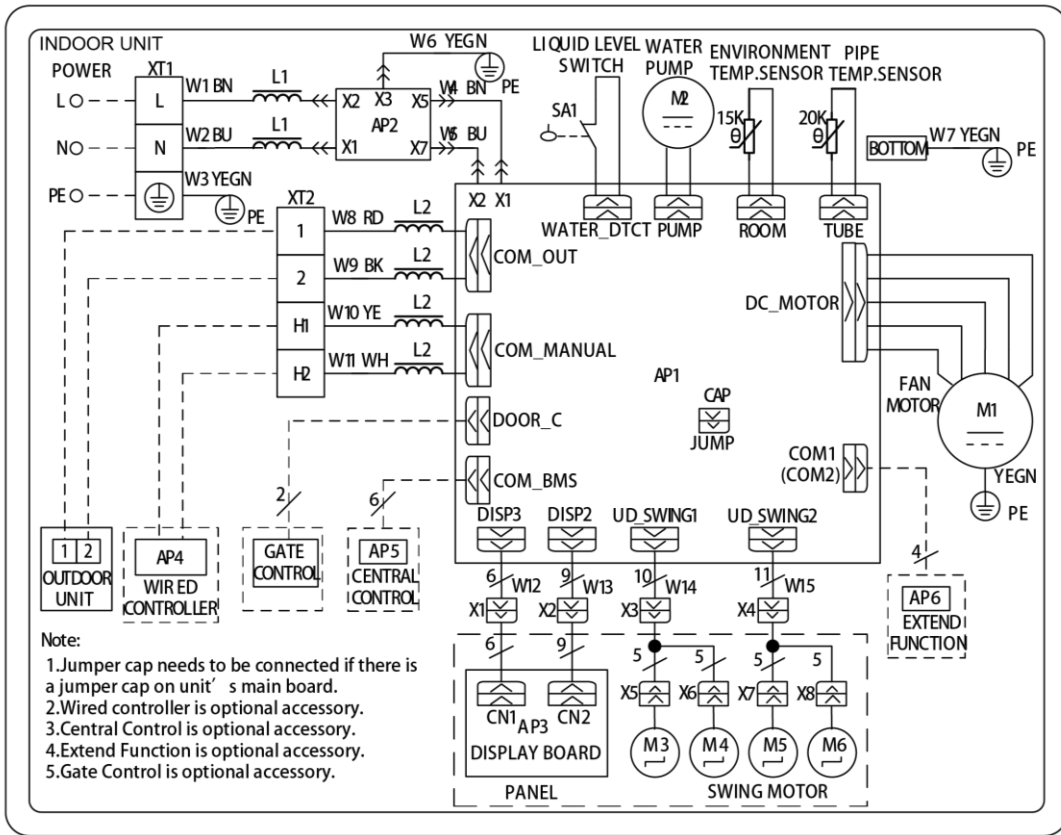

Duct Type

Model: GUD35P/A-T, GUD50P/A-T, GUD71P/A-T, GUD85P/A-T,
GUD35PS/A-T, GUD50PS/A-T, GUD71PS/A-T, GUD85PS/A-T

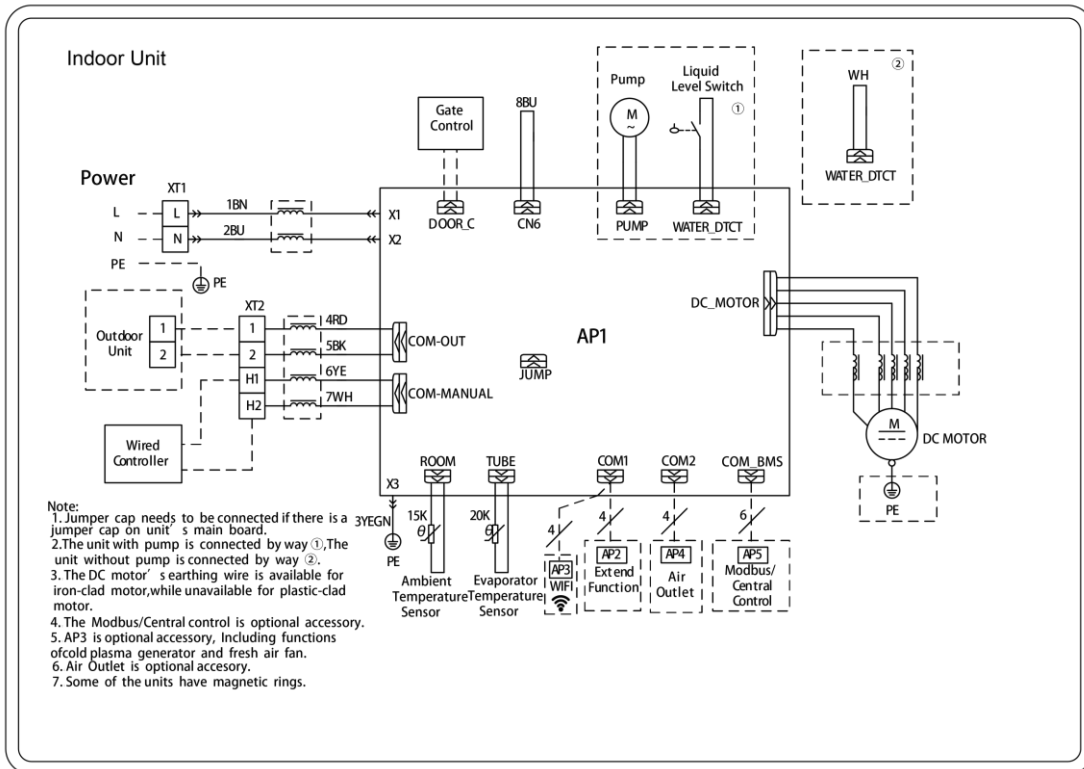

Model: GUD100PH/A-T, GUD125PH/A-T, GUD140PH/A-T
 GUD100PHS/A-T, GUD125PHS/A-T, GUD140PHS/A-T

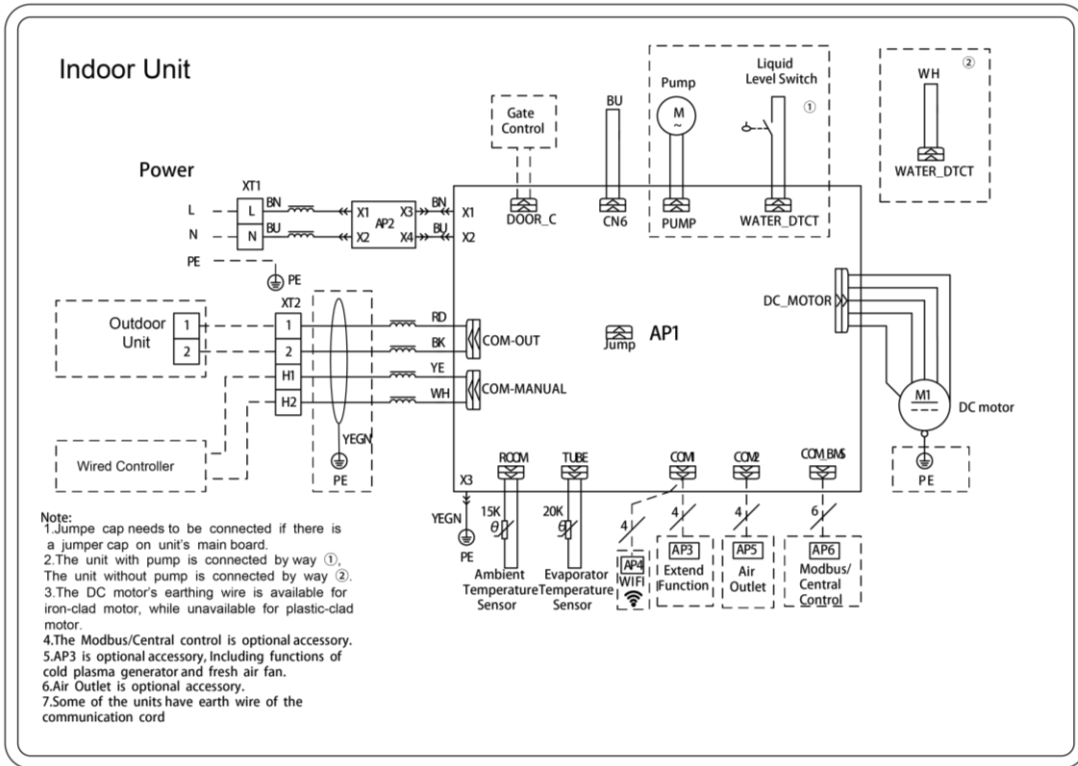

Model: GUD160PH/A-T, GUD160PHS/A-T

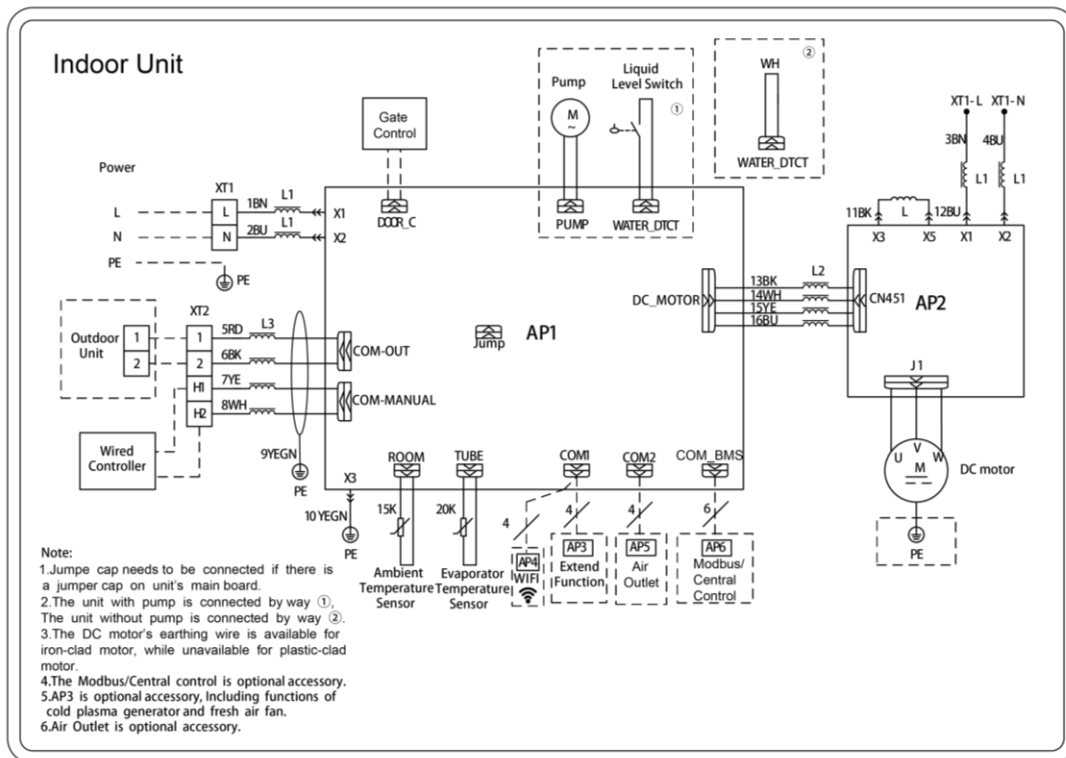

Floor Ceiling Type

Model: GUD35ZD/A-T, GUD50ZD/A-T, GUD71ZD/A-T, GUD85ZD/A-T, GUD100ZD/A-T, GUD125ZD/A-T, GUD140ZD/A-T, GUD160ZD/A-T

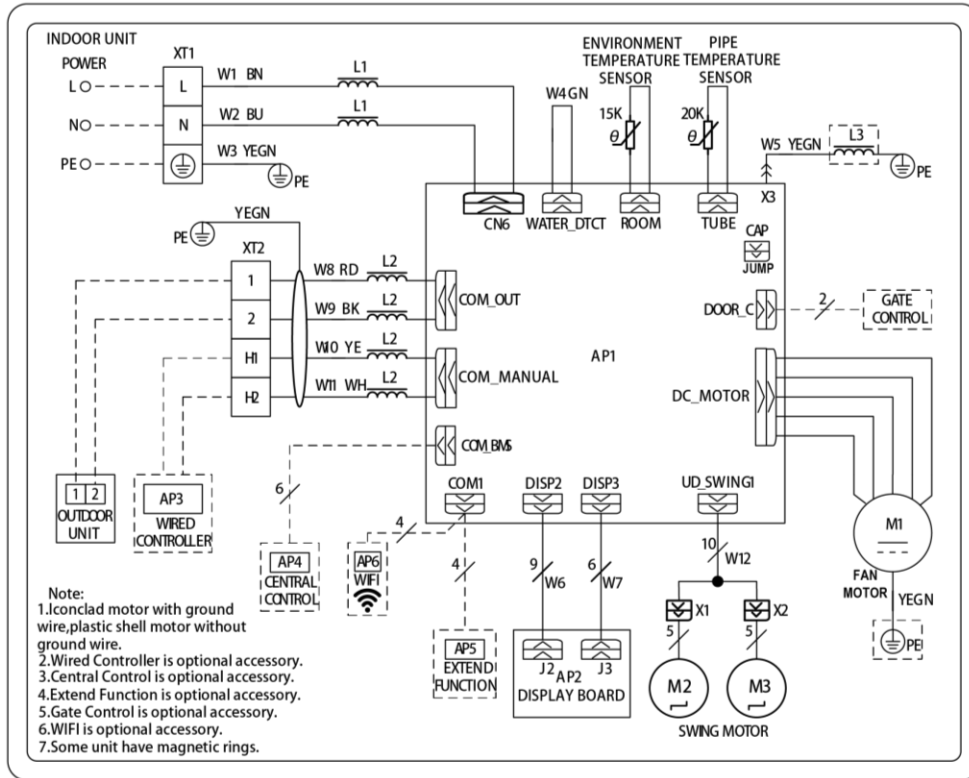

3.2 PCB Layout

3.2.1 Interface

Indoor unit:

Model: GUD35T/A-T, GUD50T/A-T, GUD71T/A-T, GUD85T/A-T:
 GUD35ZD/A-T, GUD50ZD/A-T, GUD71ZD/A-T, GUD85ZD/A-T, GUD100ZD/A-T, GUD125ZD/A-T, GUD140ZD/A-T, GUD160ZD/A-T;

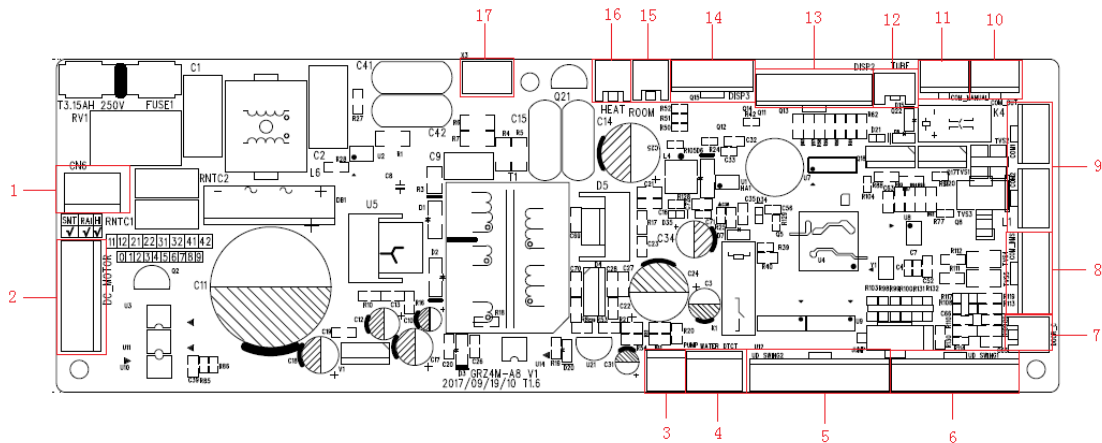

No.	Printing	Interface	No.	Printing	Interface
1	CN6	Power supply	2	DC_MOTOR	DC motor output
3	PUMP	DC water pump	4	WATER_DTCT	Water level switch
5	UD_SWING2	Vertical swing output 2	6	UD_SWING1	Vertical swing output 1
7	DOOR_C	Access control interface	8	COM_BMS	MODBUS gateway interface
9	COM1,COM2	Accessories communication interface	10	COM_OUT	ODU communication interface
11	COM_MANAUL	Wired control communication interface	12	TUBE	Evaporator temperature sensor
13	DISP2	Light board interface 2	14	DISP3	Light board interface 3
15	ROOM	Ambient temperature sensor interface	16	HEAT	Electric heating interface
17	X3	Ground wire			

Model: GUD100T/A-T, GUD125T/A-T, GUD140T/A-T, GUD160T/A-T:

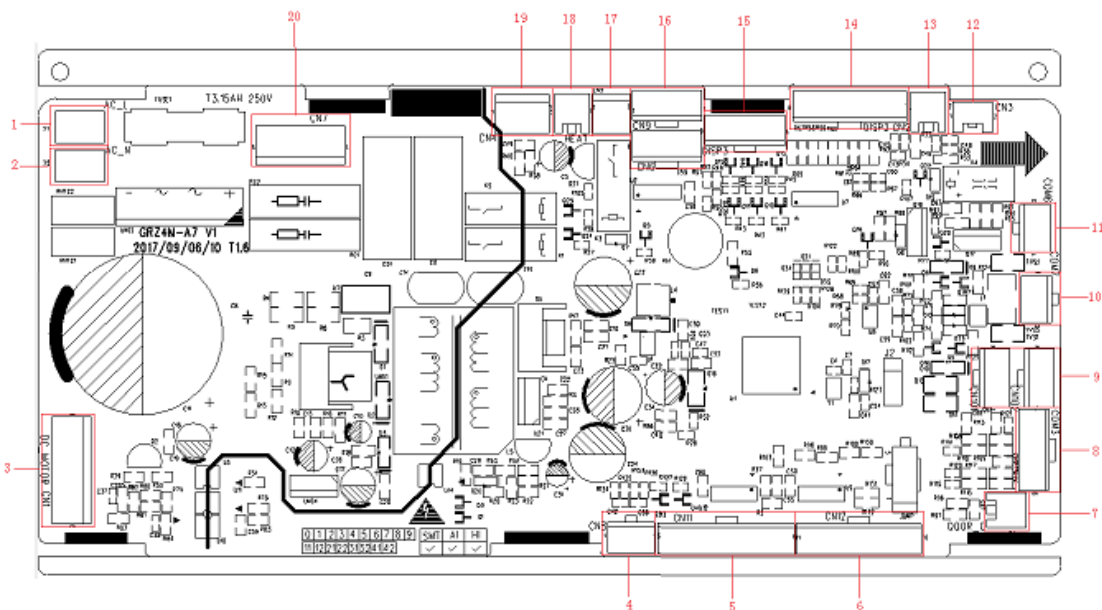

No.	Printing	Interface	No.	Printing	Interface
1	AC-L	Live wire input	2	AC-N	Neutral wire input
3	DC_MOTOR	DC motor output	4	SS	Limit switch sensing interface
5	UD_SWING2	Vertical swing output 2	6	UD_SWING1	Vertical swing output 1
7	DOOR_C	Access control interface	8	COM_BMS	MODBUS gateway interface
9	COM1, COM2	Accessories	10	COM_MANUAL	Wired control

No.	Printing	Interface	No.	Printing	Interface
		communication interface			communication interface
11	COM_OUT	ODU communication interface	12	TUBE	Indoor tube temperature sensor interface
13	ROOM	Ambient temperature sensor interface	14	DISP2	Light board interface 2
15	DISP3	Light board interface 3	16	SWING_OUT1 SWING_OUT2	Air outlet lifting output 1 Air outlet lifting output 2
17	PUMP	DC water pump interface	18	HEAT	Electric heating interface
19	WATER_DTCT	Water level switch	20	CN7	Air return lifting output

Model: GUD35P/A-T, GUD50P/A-T, GUD71P/A-T, GUD85P/A-T, GUD100PH/A-T, GUD125PH/A-T, GUD140PH/A-T, GUD160PH/A-T;
 GUD35PS/A-T, GUD50PS/A-T, GUD71PS/A-T, GUD85PS/A-T, GUD100PHS/A-T, GUD125PHS/A-T, GUD140PHS/A-T, GUD160PHS/A-T

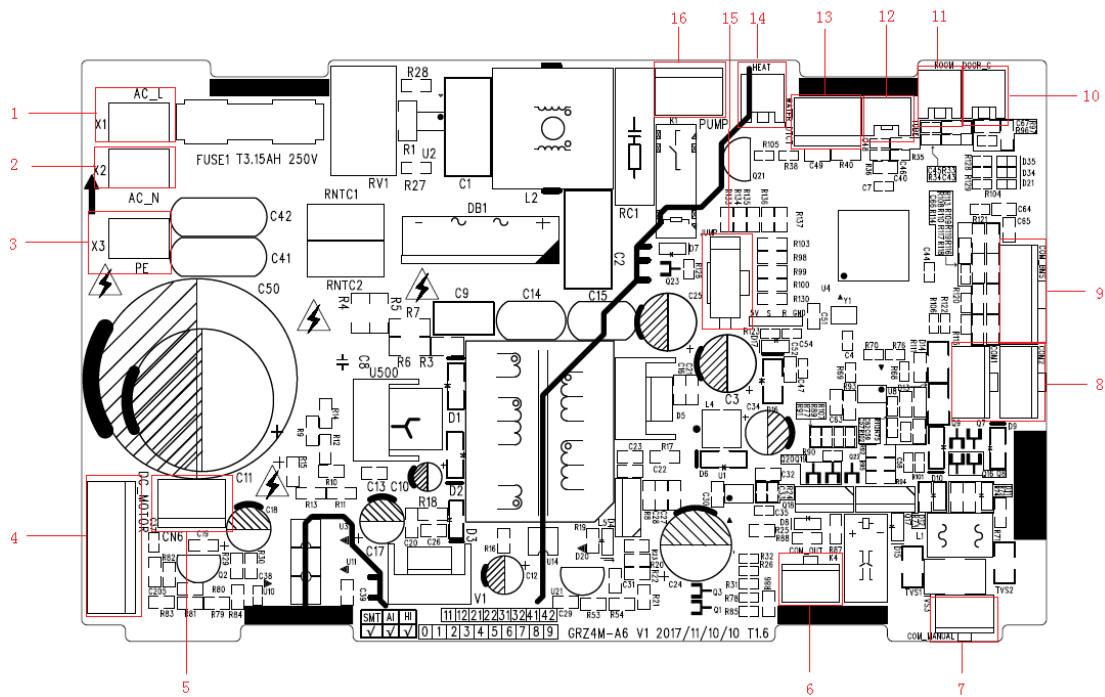

No.	Printing	Interface	No.	Printing	Interface
1	AC-L	Live wire input	2	AC-N	Neutral wire input
3	PE	Ground wire	4	DC-MOTOR	DC motor output
5	CN6	Motor type selection interface	6	COM-OUT	ODU communication interface
7	COM-MANUAL	Wired control communication interface	8	COM1, COM2	Accessories communication

No.	Printing	Interface	No.	Printing	Interface
					interface
9	COM_BMS	MODBUS gateway interface	10	DOOR_C	Access control sensing interface
11	ROOM	Room ambient temperature sensor interface	12	TUBE	Indoor tube temperature sensor interface
13	WATER_DTCT	Water overflow detection	14	HEAT	Auxiliary heating interface (reserved)
15	JUMP	Jumper cap	16	PUMP	Water pump interface

Model: GUD35W/NhA-T, GUD50W/NhA-T

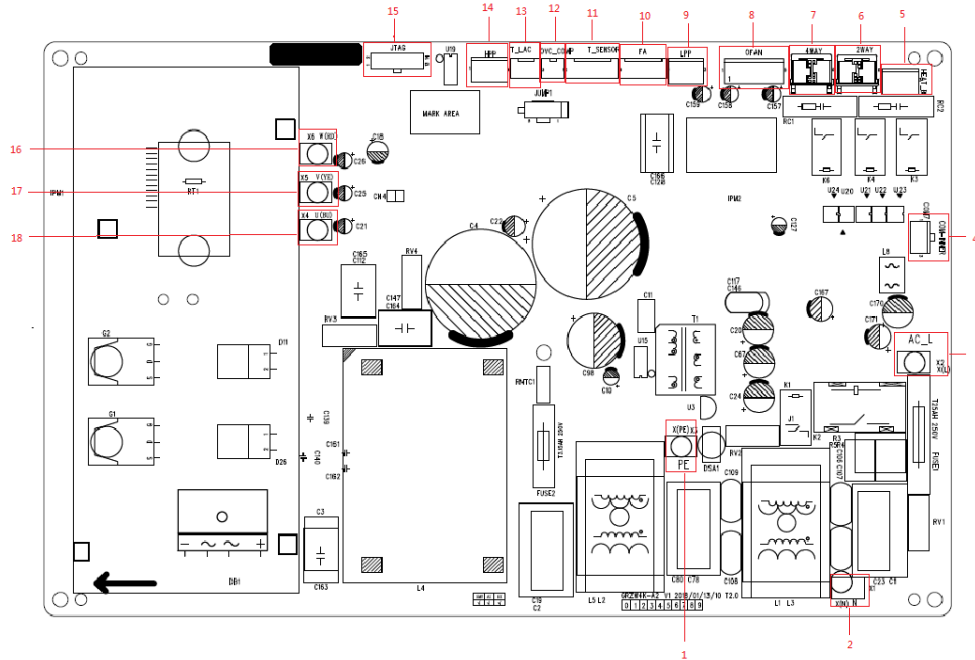

Mainboard

No.	Printing	Interface	No.	Printing	Interface
1	X3	Ground wire	2	X1	Neutral wire
3	X2	Live wire	4	COM7	IDU communication interface
5	HEAT_B	Chassis electric heating	6	2WAY	2-way valve
7	4WAY	4-way valve	8	OFAN	External drive DC fan
9	LPP	System low pressure protection interface	10	FA	Solenoid expansion valve
11	T_SENSOR	Temperature sensor group	12	OVC_COMP	Compressor overload detection
13	T_LAC	Low temperature cooling temperature sensor	14	HPP	System high pressure protection interface

No.	Printing	Interface	No.	Printing	Interface
15	JTAG	Programming	16	X6	Inverter compressor W phase
17	X5	Inverter compressor V phase	18	X4	Inverter compressor U phase

Model: GUD71W/NhA-T, GUD85W/NhA-T
Mainboard

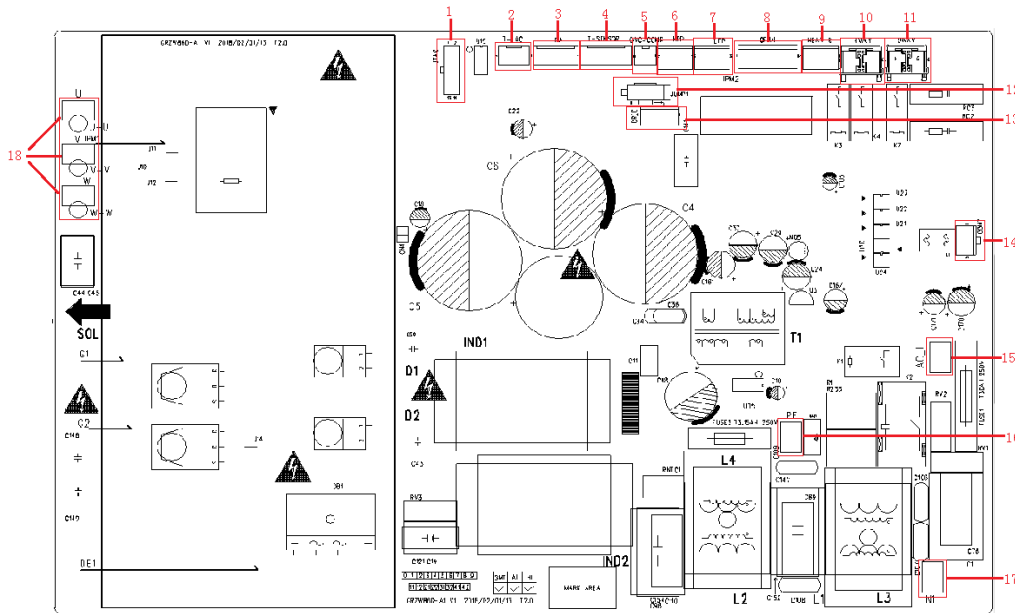

No.	Printing	Interface	No.	Printing	Interface
1	JTAG	Programming interface	10	2WAY	2-way valve
2	T-LAC	Low temperature cooling temperature sensing interface	11	HEAT-B	Chassis electric heating
3	FA	Electronic expansion valve	12	JUMP1	Jumper cap
4	T-SENSOR	Temperature sensor	13	DRED	DRED
5	OVC-COMP	Compressor overload detection	14	COM7	IDU and ODU communication interface
6	HPP	High pressure switch	15	AC-L	AC input live wire
7	LPP	Low pressure switch	16	N1	AC input neutral wire
8	OFAN	DC fan interface	17	PE	AC input ground wire
9	4WAY	4-way valve	18	U/V/W	Compressor interface

Model: GUD100W/NhA-T, GUD125W/NhA-T, GUD140W/NhA-T,
 GUD100W/NhA-X, GUD125W/NhA-X, GUD140W/NhA-X, GUD160W/NhA-X:
 Mainboard

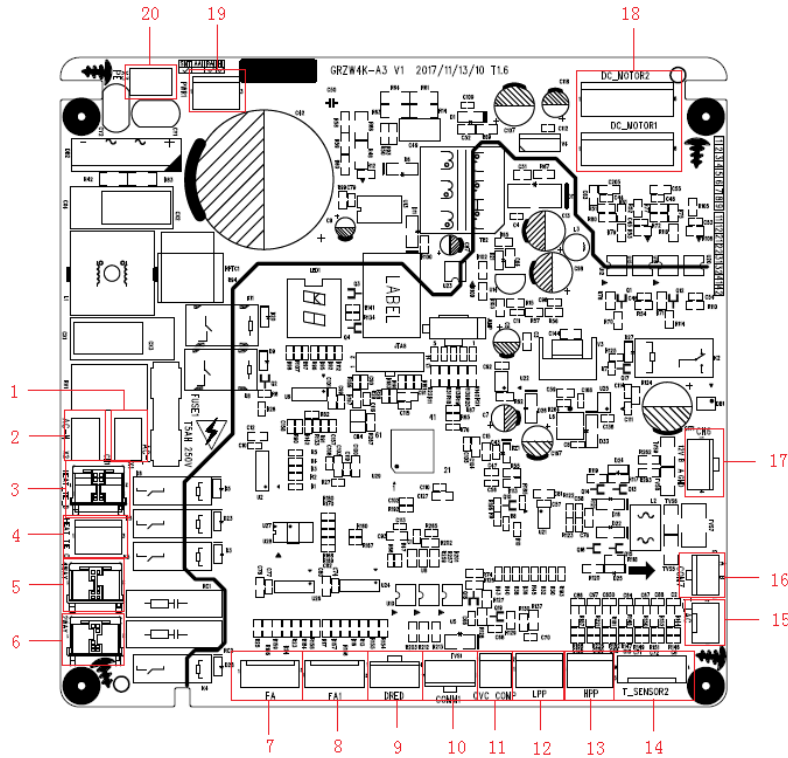

No.	Printing	Interface	No.	Printing	Interface
1	AC-L	Live wire input	2	AC-N	Neutral wire input
3	HEAT_TIE_B	Chassis electric heating belt	4	HEAT_TIE_C	Compressor electric heating belt
5	4WAY	4-way valve	6	2WAY	2-way valve
7	FA	Electronic expansion valve interface	8	FA1	Electronic expansion valve 1 interface Refrigerant heat dissipation
9	DRED	DRED communication interface	10	COMM1	Drive communication interface
11	OVC_COMP	Compressor overload protection interface	12	LPP	System low pressure protection interface
13	HPP	System high pressure protection interface	14	T_SENSOR2	2. Outdoor tube temperature sensor interface 4. Outdoor ambient temperature sensor interface 6. Discharge temperature sensor interface
15	T_LAC	Low temperature cooling temperature sensing	16	COM7	Unit communication interface
17	CN6	GPRS communication interface	18	DC_MOTOR1 DC_MOTOR2	DC motor output
19	PWR1	310V DC power supply interface	20	PE	Ground wire interface

Model: GUD100W/NhA-T

(1) Drive Board

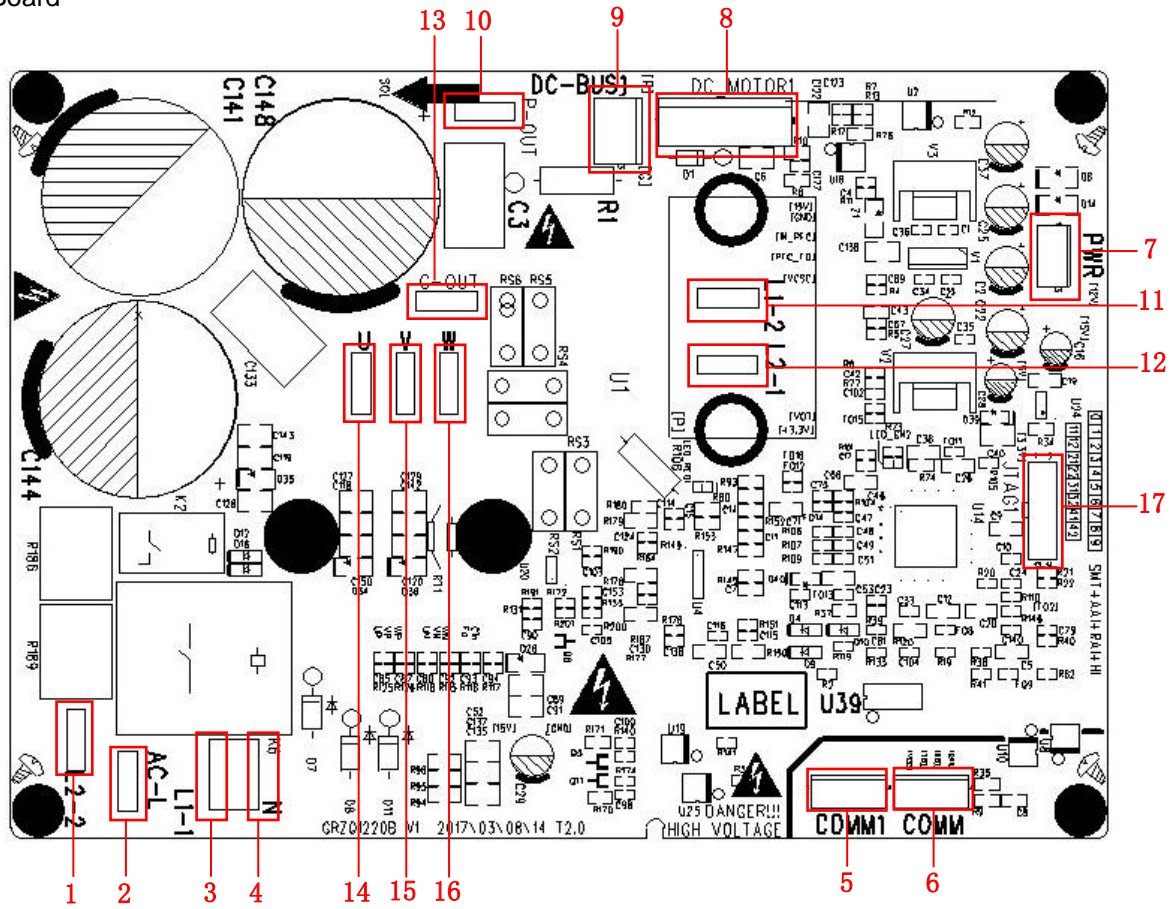

No.	Printing	Interface	No.	Printing	Interface
1	L2-2	PFC induction wire (blue)	10	P-OUT	Reserved
2	AC-L	Live wire	11	L1-2	PFC induction wire (white)
3	L1-1	PFC induction wire (brown)	12	L2-1	PFC induction wire (yellow)
4	N	Neutral wire	13	G-OUT	Reserved
5	COMM1	Communication terminal, same with COMM	14	U	Compressor U phase terminal
6	COMM	Communication terminal, same with COMM1	15	V	Compressor V phase terminal
7	PWR	Drive power supply terminal	16	W	Compressor W phase terminal
8	DC-MOTOR1	DC fan terminal	17	JTAG1	Programming interface (for testing)
9	DC-BUS1	Power discharge terminal (for testing)			

(2) Filtering Board

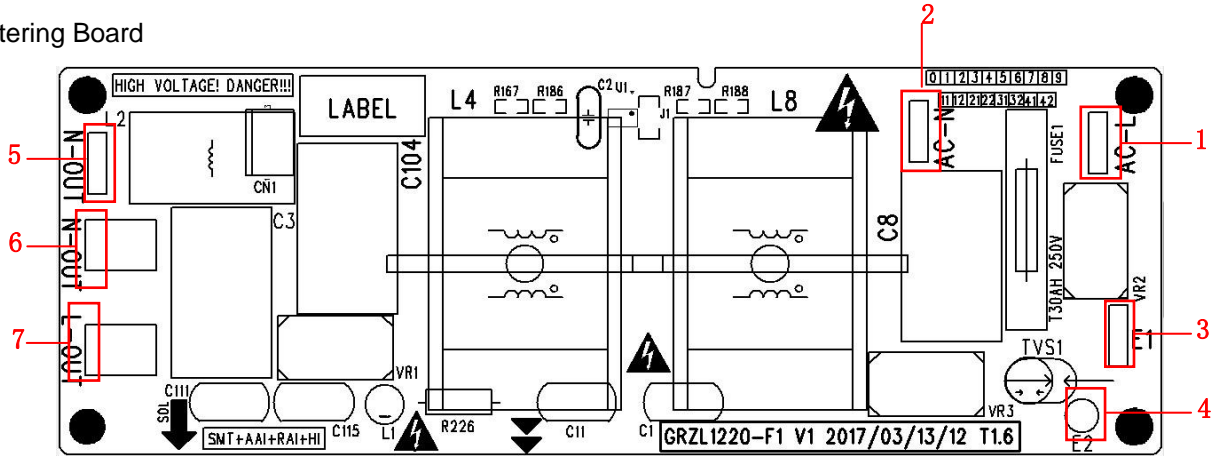

No.	Printing	Interface	No.	Printing	Interface
1	AC-L	Power input live wire terminal	5	N-OUT	Power output neutral wire terminal (reserved)
2	AC-N	Power input neutral wire terminal	6	N-OUT	Power output neutral wire terminal
3	E1	Filtering board ground wire terminal	7	L-OUT	Power output live wire terminal
4	E2	Filtering board grounding hole (reserved)			

(3) Power board

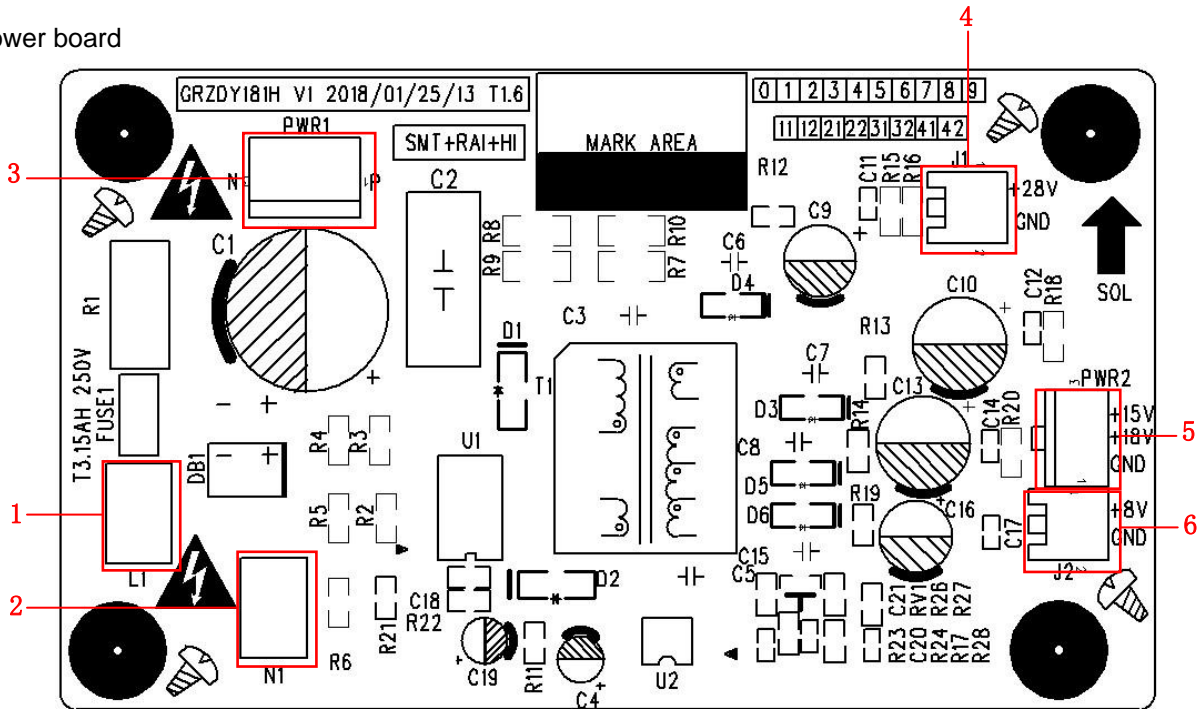

No.	Printing	Interface	No.	Printing	Interface
1	L1	Power live wire terminal (reserved)	4	J1	+28V terminal (reserved)
2	N1	Power neutral wire terminal (reserved)	5	PWR2	Drive power supply terminal
3	PWR1	DC busbar terminal	6	J2	+8V terminal (reserved)

Model: GUD100W/NhA-X, GUD125W/NhA-X, GUD140W/NhA-X, GUD160W/NhA-X

Drive Board

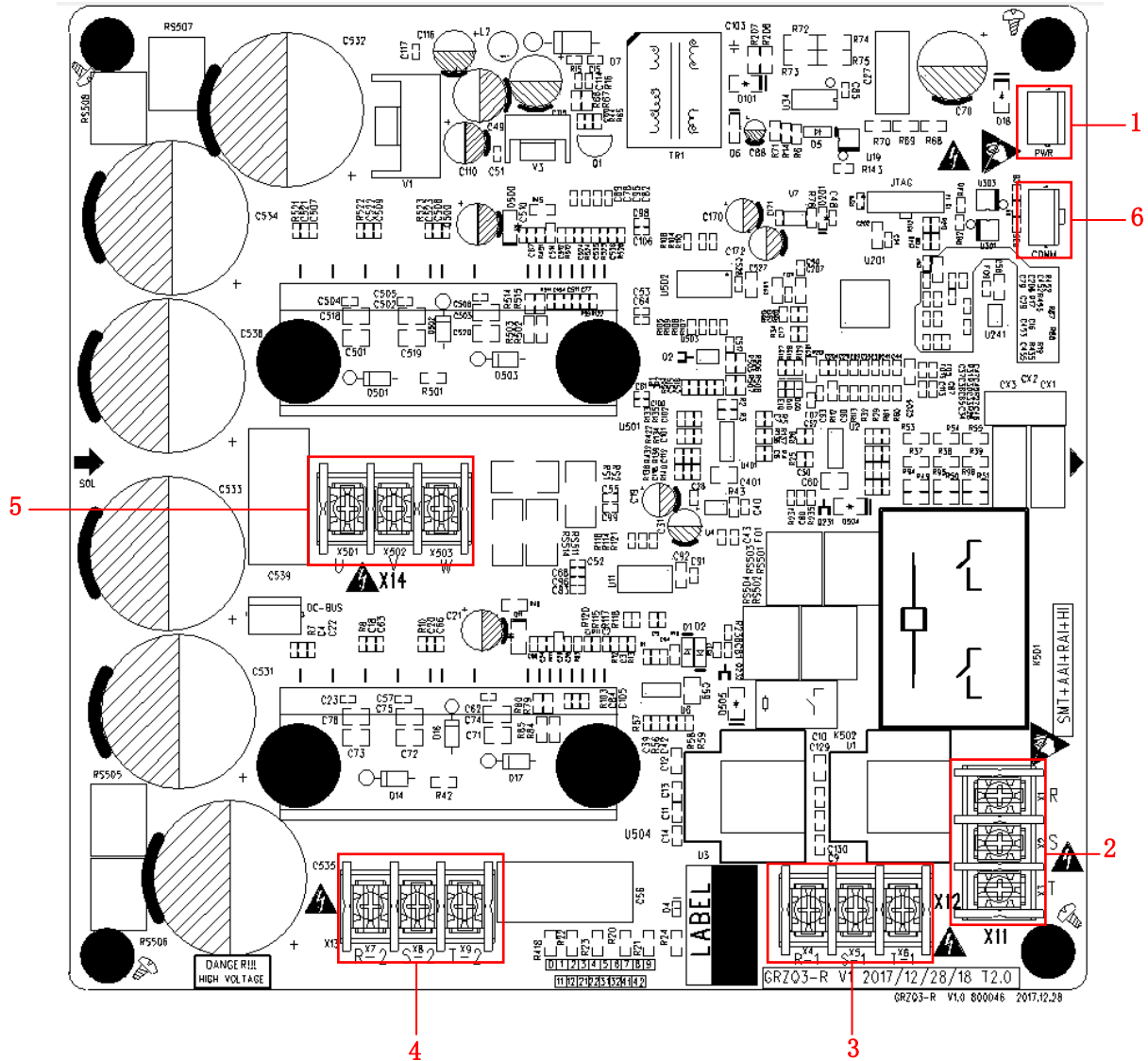

No.	Printing	Interface
1	PWR	Power supply busbar input terminal
2	X1/ X2/X3	Mainboard power supply 3-phase input terminal
3	X4/ X5/X6	Electric reactor 3-phase connection terminal (input terminal)
4	X7/ X8/X9	Electric reactor 3-phase connection terminal (output terminal)
5	X501/X502/X503	Compressor 3-phase connection terminal
6	COMM	Communication interface

Filtering Board

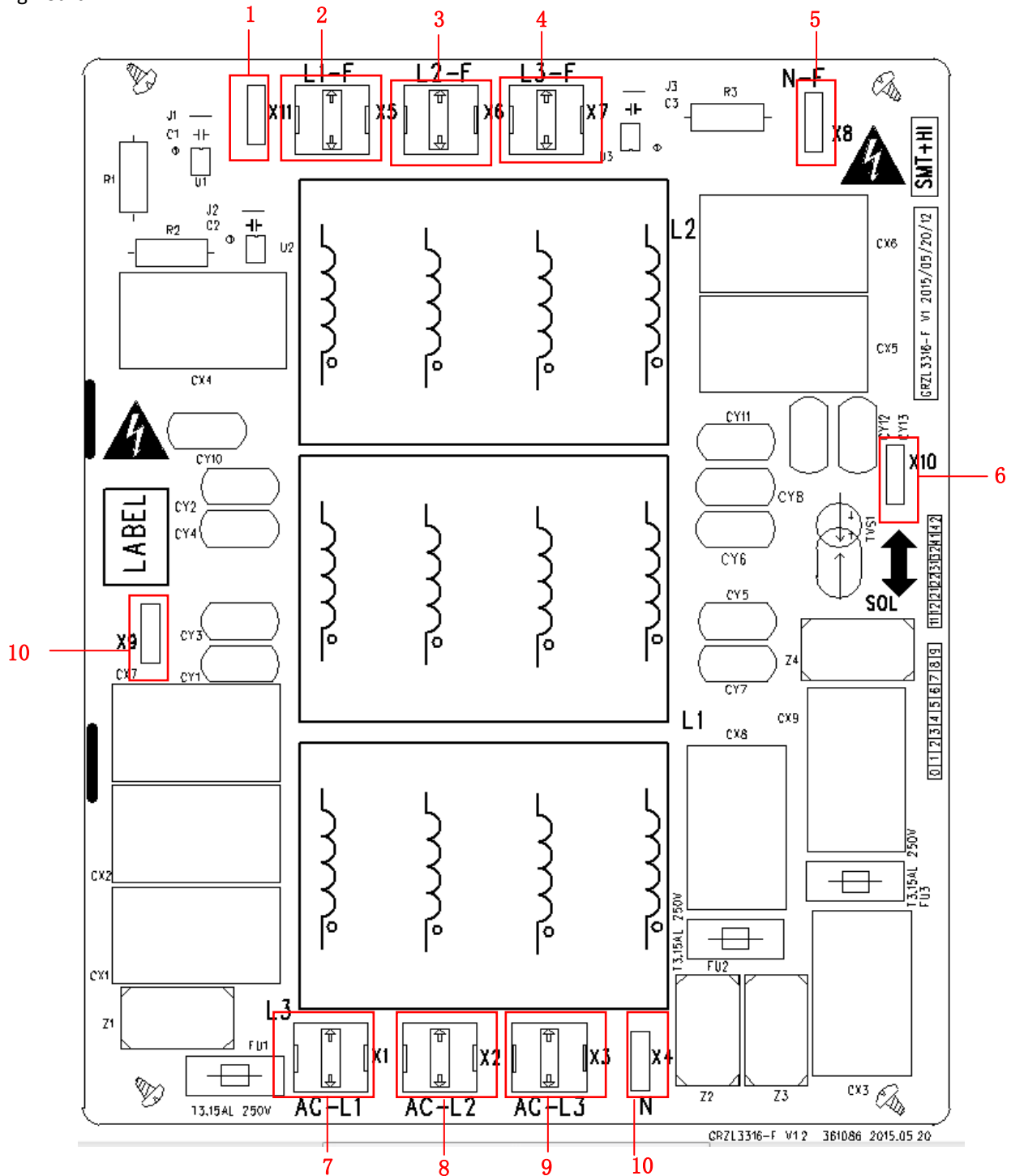

No.	Printing	Interface	No.	Printing	Interface
1	X11	Power output live wire AC-L1 (connect to master control board AC-L)	7	X3	Unit power input wire AC-L3
2	X5	Power output wire L1-F (connect to drive board L1-F)	8	X2	Unit power input wire AC-L2
3	X6	Power output wire L2-F (connect to drive board L2-F)	9	X1	Unit power input wire AC-L1
4	X7	Power output wire L3-F (connect to drive board L3-F)	10	X9	Ground wire
5	X8	Power output wire N-F (connect to	11	X4	Unit power input

No.	Printing	Interface	No.	Printing	Interface
		master control board N)			neutral wire N
6	X10	Ground wire E, reserved			

Model: GUD125W/NhA-T, GUD140W/NhA-T

Drive Board:

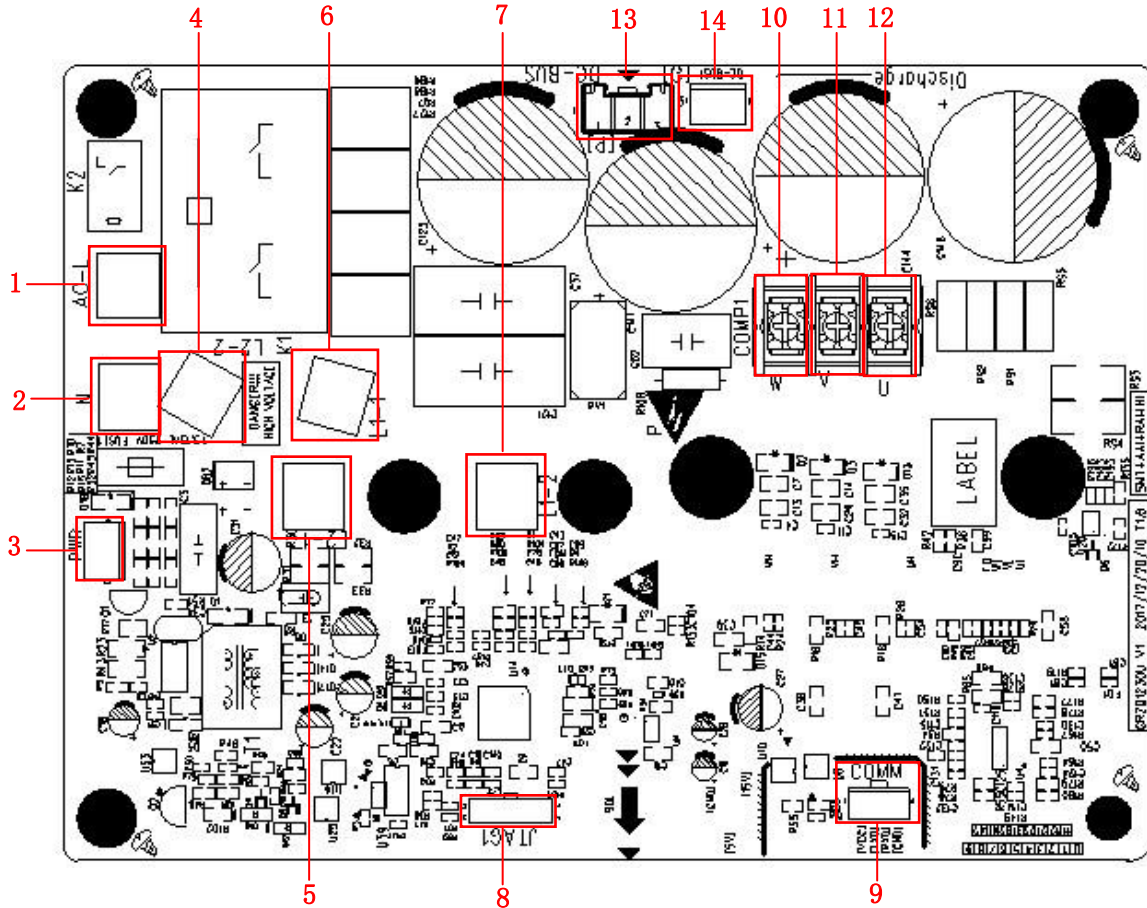

No.	Printing	Interface	No.	Printing	Interface
1	AC-L	Live wire	8	JTAG1	Programming interface (for testing)
2	N	Neutral wire	9	COMM	Communication interface
3	PWR	Drive power supply busbar terminal	10	W	Compressor W phase
4	L2-2	PFC induction wire (white)	11	V	Compressor V phase
5	L2-1	PFC induction wire (white)	12	U	Compressor U phase
6	L1-1	PFC induction wire (white)	13	DC-BUS	DC busbar terminal
7	L1-2	PFC induction wire (white)	14	DC-BUS1	Power discharge terminal (for testing)

Filtering Board:

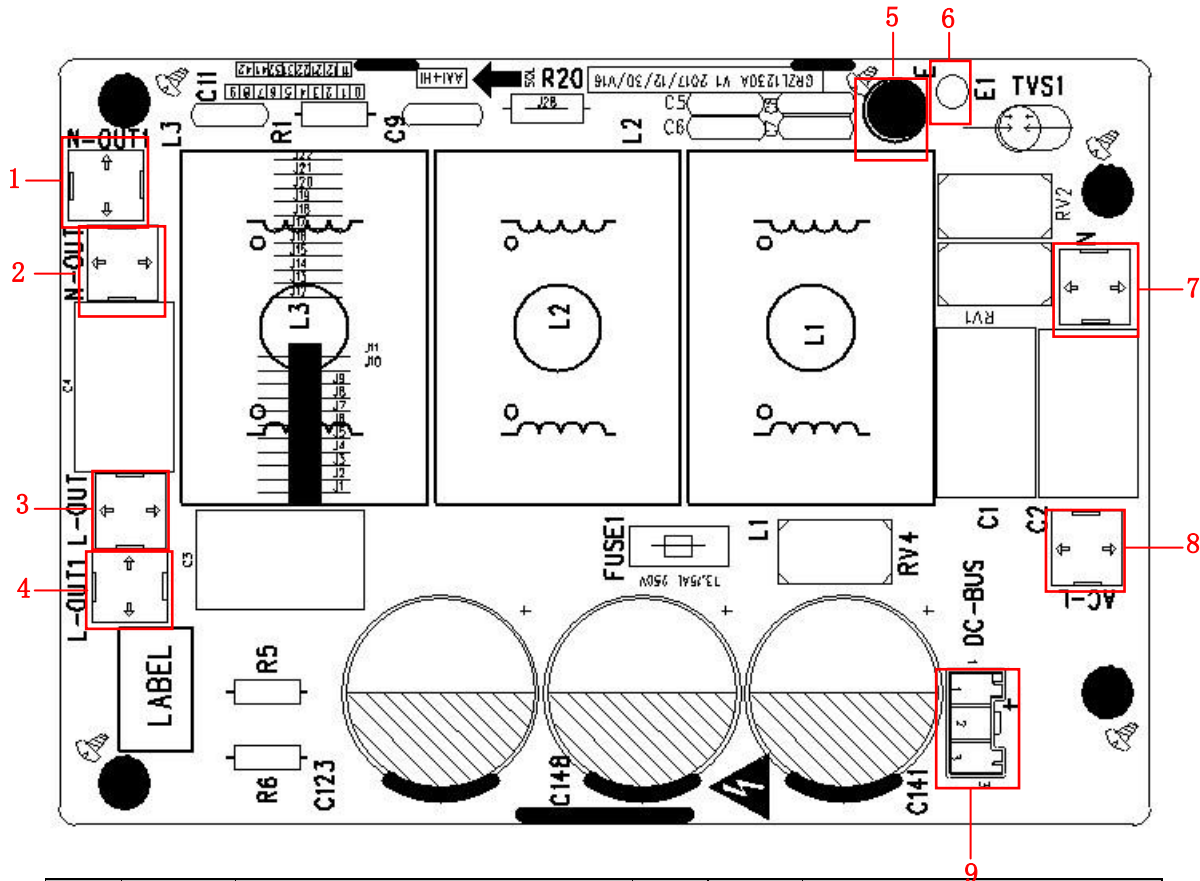

No.	Printing	Interface	No.	Printing	Interface
1	N-OUT1	Power output neutral wire terminal (for U-MATCH)	6	E1	Filtering board grounding hole (reserved)
2	N-OUT	Power output neutral wire terminal (reserved for other models)	7	N	Power input neutral wire terminal
3	L-OUT	Power output live wire terminal (reserved for other models)	8	AC-L	Power input live wire terminal
4	L-OUT1	Power output live wire terminal (for U-MATCH)	9	DC-BUS	DC busbar terminal
5	E	Filtering board grounding hole			

3.2.2 IPM,PFC Testing Method

3.2.2.1 Method of Testing IPM Module

(1). Preparation before test: prepare a universal meter and turn to its diode option, and then remove the wires U, V, W of the compressor after it is powered off for one minute.

(2). Testing Steps

Step 1: put the black probe on the place P and the red one on the wiring terminal U, V, W respectively as shown in the following figure to measure the voltage between UP, VP and WP.

Step 2: put the red probe on the place N and the black one on the wiring terminal U, V, W respectively as shown in the following figure to measure the voltage between NU, NV and NW.

(3). If the measured voltages between UP, VP, WP, NU, NV, NW are all among 0.3V-0.7V, then it indicates the IPM module is normal; If any measured value is 0, it indicates the IPM is damaged.

3.2.2.2 Method of Testing PFC Module Short Circuit: (only for GUD100W/NhA-T, GUD125W/NhA-T, GUD140W/NhA-T)

(1). Preparation before test: prepare a universal meter and turn to its diode option, and then remove the wires L1-2, L2-1 after it is powered off for one minute.

(2). Testing Steps:

Step 1: put the black probe on the place P and the red one on the wiring terminal L1-2, L2-1 respectively as shown in the following figure to measure the voltage between L1-2P and L2-1 P.

Step 2: put the red probe on the place N and the black one on the wiring terminal L1-2, L2-1 respectively as shown in the following figure to measure the voltage between N L1-2 and NL2-1.

(3). If the measured voltages between L1-2P ,L2-1 P, N L1-2 , NL2-1 are all among 0.3V-0.7V, then it indicates the PFC module is normal; If any measured value is 0, it indicates the PFC is damaged.

◆ GUD100W/NhA-T

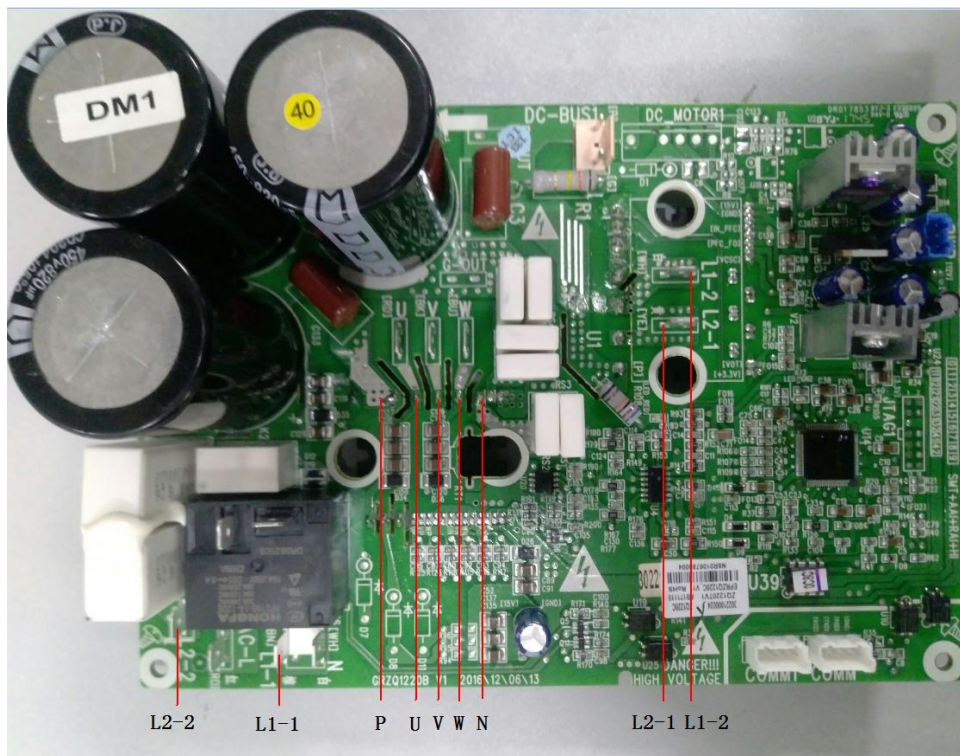

◆ GUD125W/NhA-T , GUD140W/NhA-T

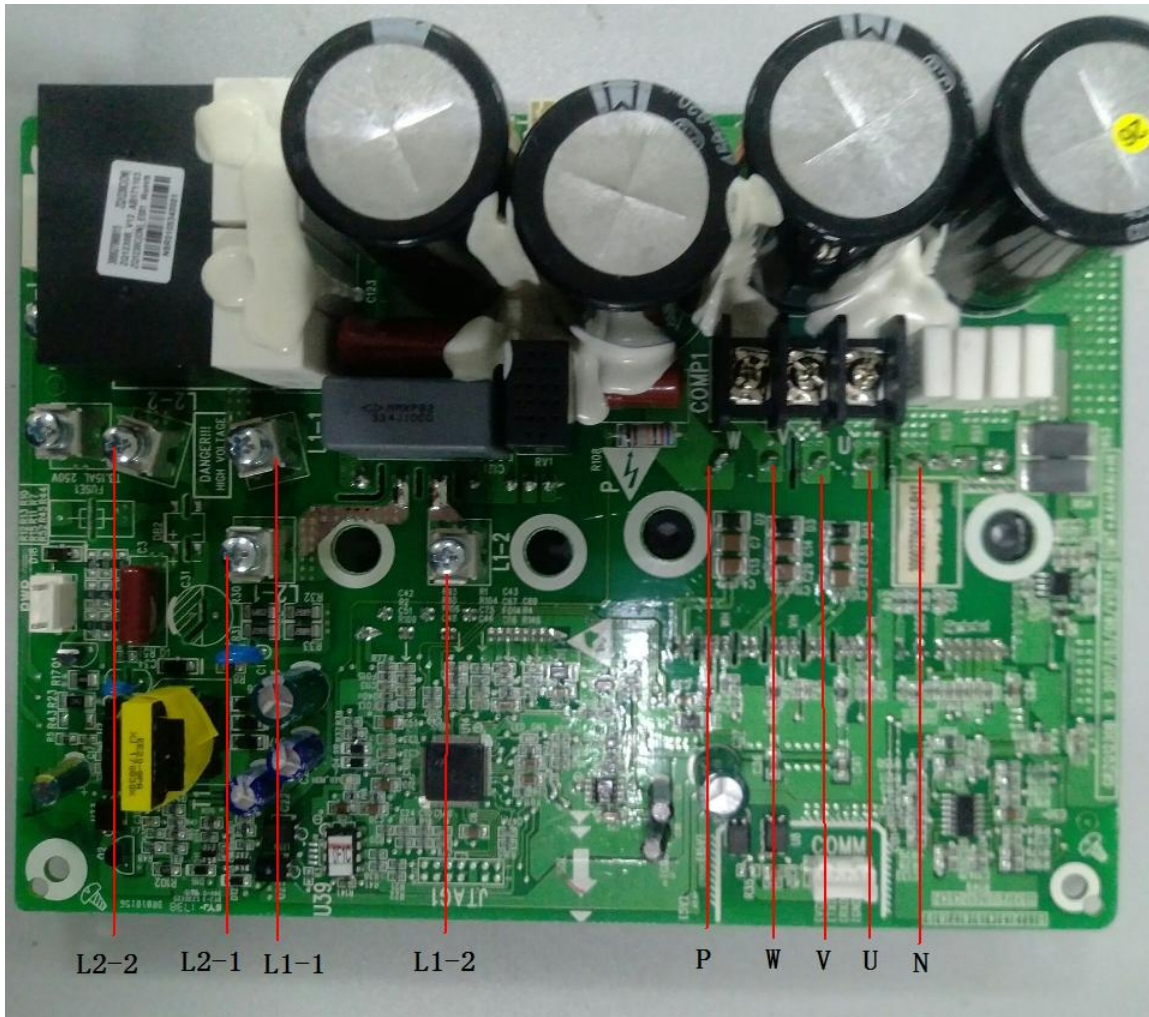

3.3 Error Code

Number	Error code	Error
1	E1	Compressor high pressure protection
2	E2	Indoor anti-freeze protection
3	E3	Compressor low pressure protection, refrigerant lack protection and refrigerant collecting mode
4	E4	Compressor air discharge high-temperature protection
5	E6	Communication error
6	E8	Indoor fan error
7	E9	Water-full protection
8	F0	Indoor ambient temperature sensor error
9	F1	Evaporator temperature sensor error
10	F2	Condenser temperature sensor error
11	F3	Outdoor ambient temperature sensor error
12	F4	Discharge temperature sensor error

Number	Error code	Error
13	F5	Wired control temperature sensor error
14	C5	IDU jumper cap error
15	EE	IDU or ODU memory chip error
16	PF	Electric box sensor error
17	H3	Compressor overload protection
18	H4	Overload
19	H5	IPM protection
20	H6	DC fan error
21	H7	Driver out-of-step protection
22	HC	Pfc protection
23	Lc	Startup failure
24	Ld	Compressor phase-sequence protection
25	LF	Power protection
26	Lp	IDU and ODU unmatched
27	U7	4-way valve switch-over error
28	P0	Driver reset protection
29	P5	Over-current protection
30	P6	Master control and driver communication error
31	P7	Driver module sensor error
32	P8	Driver module high temperature protection
33	P9	Zero-crossing protection
34	PA	AC current protection
35	Pc	Driver current error
36	Pd	Sensor connection protection
37	PE	Temperature drift protection
38	PL	Bus low-voltage protection
39	PH	Bus high-voltage protection
40	PU	Charge loop error
41	PP	Input voltage error
42	ee	Drive memory chip error
43	C4	ODU jumper cap error
44	dJ	Phase-loss and anti-phase protection
45	oE	ODU error, for specific error please see the status of ODU indicator
46	EL	Emergency stop (fire alarm)

If malfunction occurs during operation, LCD temperature display zone will show the failure information. If several malfunctions occur at the same time, their corresponding error codes will be shown in turn. When malfunction occurs, please shut off the unit and send for professional personnel to repair. For example, E1 (as shown below) indicates high pressure protection.

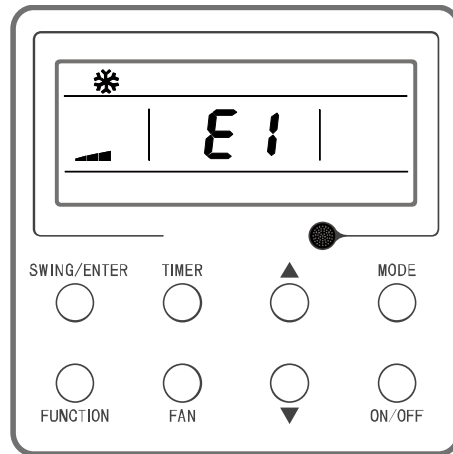

3.4 Troubleshooting

3.4.1 “E1” Compressor High Pressure Protection

Error display: ODU mainboard, IDU wired control and IDU receiver light board will display **E1**

Error judgment condition and method:

It is judged through the action of high pressure switch. If the high pressure switch is cut off, it is judged that high pressure is too high and the system stops operation for protection.

Possible reason:

- Cut-off valve of ODU is not fully opened;
- High pressure switch is abnormal;
- Outdoor or indoor fan is not working properly;
- IDU filter or air duct is blocked (heating mode);
- Ambient temperature is too high;
- Refrigerant charging amount is too much;
- System pipeline is blocked

Troubleshooting:

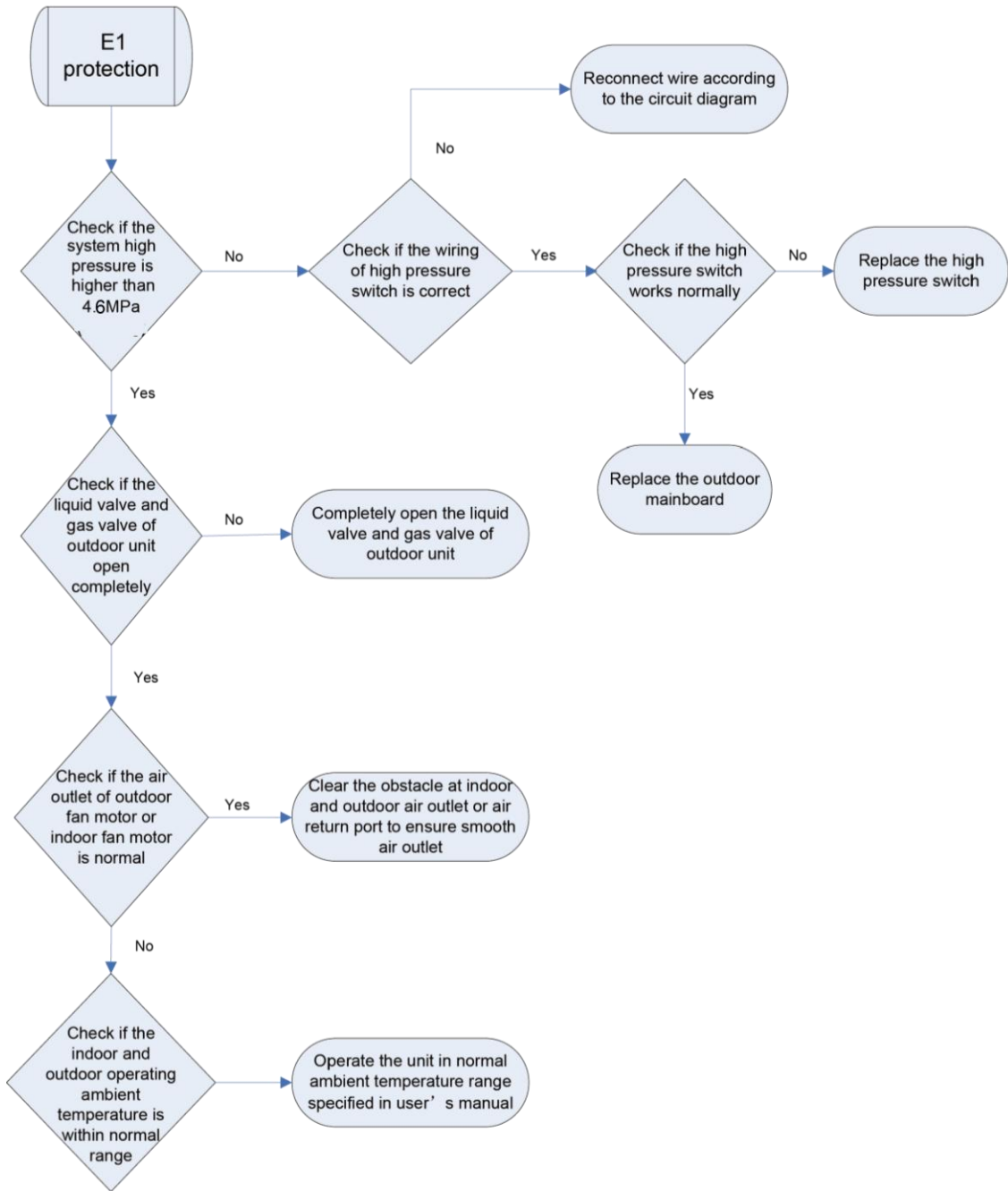

3.4.2 “E2” Indoor Anti-freezing Protection

Error display: IDU wired control and IDU receiver light board will display **E2**

Error judgment condition and method:

Check IDU pipe temperature. When pipe temperature is too low, freeze protection will be activated to prevent freezing damage of evaporator.

Possible reason:

- IDU filter and evaporator are dirty
- IDU motor is blocked
- Refrigerant amount is insufficient

■Ambient temperature of IDU and ODU is too low

Troubleshooting:

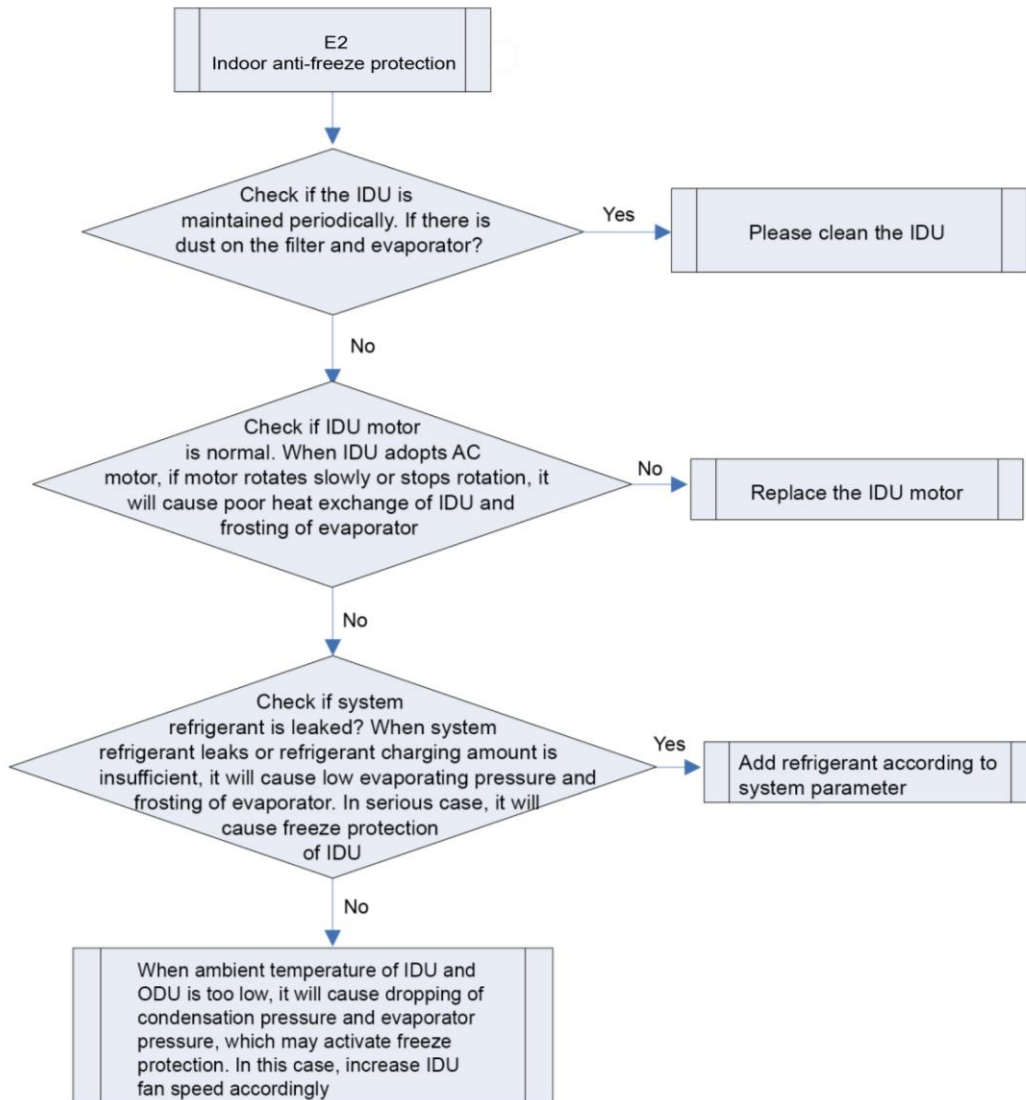

3.4.3 “E3” Compressor Low-pressure Protection, Refrigerant Shortage Protection, Refrigerant Recovery Mode

Error display: ODU mainboard, IDU wired control and IDU receiver light board will display **E3**

Error judgment condition and method:

It is judged through the action of low pressure switch. If the low pressure switch is cut off, it is judged that low pressure is too low and the system stops operation for protection.

Possible reason:

- Cut-off valve of ODU is not fully opened;
- Low pressure sensor is abnormal;
- Outdoor or indoor fan is not working properly;
- IDU filter or air duct is blocked (cooling mode);
- Ambient temperature is too low;

- Refrigerant charging amount is insufficient;
- System pipeline is blocked;

Troubleshooting:

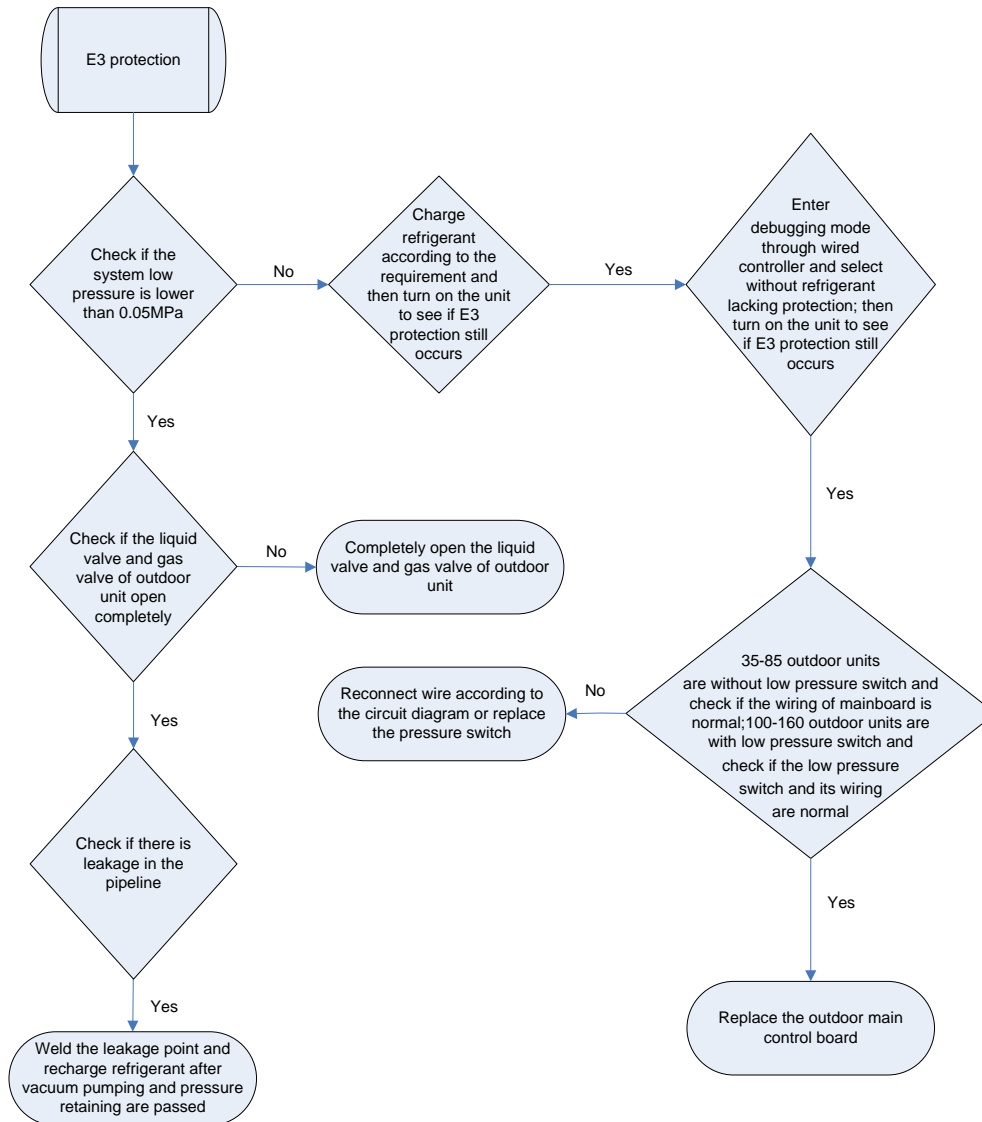

3.4.4 “E4” Compressor Air Discharge High-temperature Protection

Error display: ODU mainboard, IDU wired control and IDU receiver light board will display **E4**

Error judgment condition and method:

Test the compressor discharge temperature through compressor discharge pipe and shell top temperature sensor. If the tested temperature value is higher than 115°C, the unit will stop for protection

Possible reason:

- Cut-off valve of ODU is not fully opened;
- Electronic expansion valve is abnormal;
- Outdoor or indoor fan is not working properly;
- IDU filter or air duct is blocked (cooling mode);
- Ambient temperature exceeds allowable operation range;
- Refrigerant charging amount is insufficient;
- System pipeline is blocked;

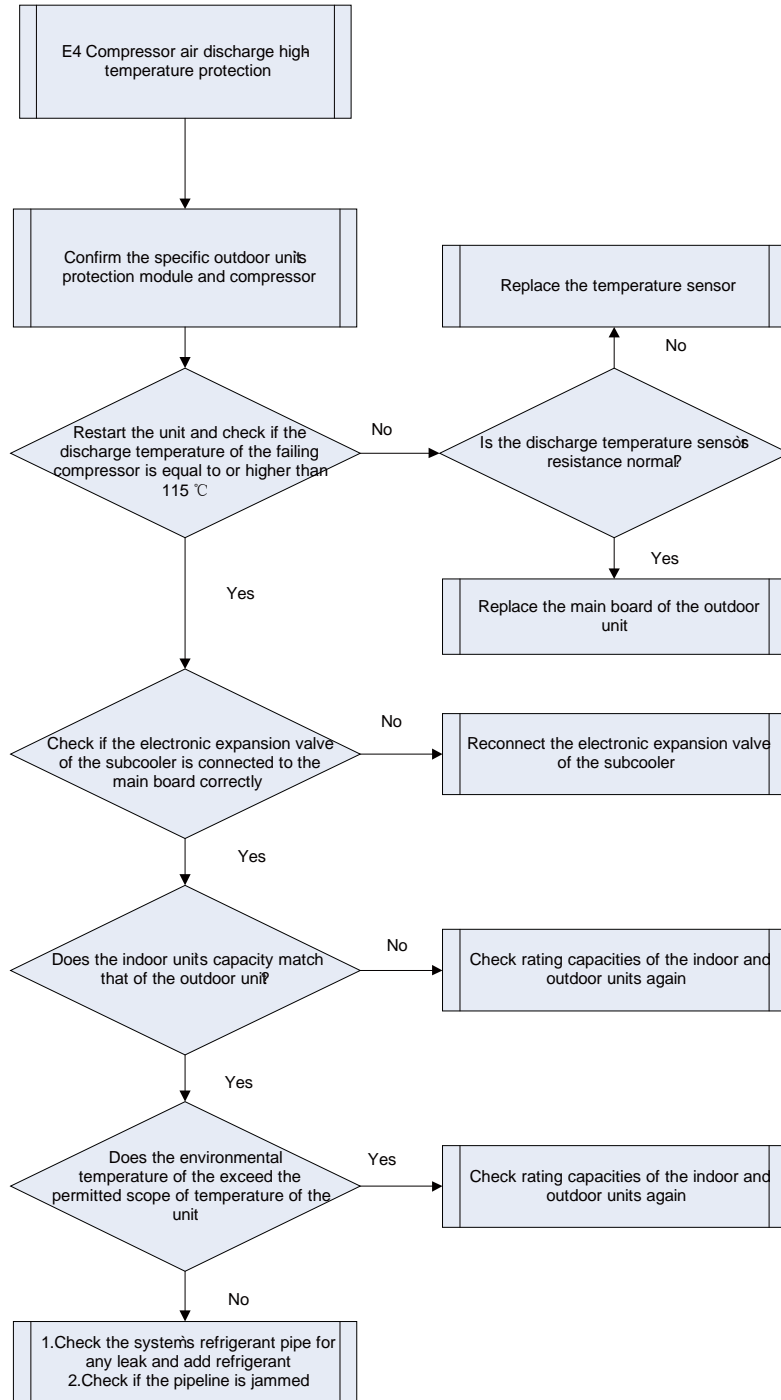
Troubleshooting:

3.4.5 “E6” Communication Error

Error display: ODU mainboard, IDU wired control and IDU receiver light board will display **E6**

Error judgment condition and method:

If no communication between ODU and IDU or between IDU and wired controller in continuously 120s, this error will be reported.

Possible reason:

- Communication wire is connected improperly or loose.
- Communication wire is cut off
- Communication wire is in poor connection

- Connected wired controller quantity or address setting is improper
- Controller is abnormal

Troubleshooting:

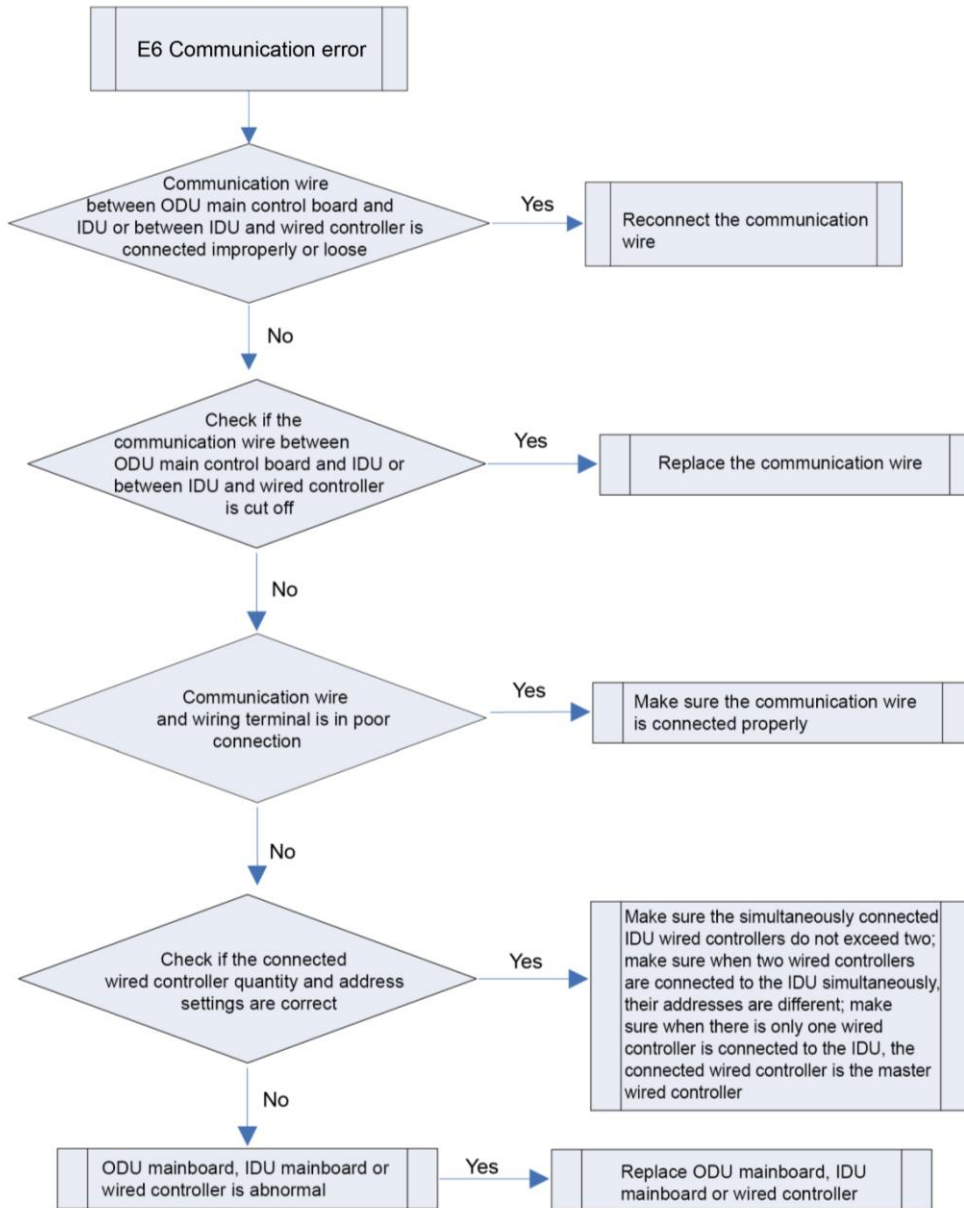

3.4.6 “E8” Indoor Fan Error

Error display: IDU wired control and IDU receiver light board will display **E8**

Error judgment condition and method:

Check if the rotation speed of IDU is too slow, or it stops rotation, or protection signal of outdoor fan is transferred. If yes, it is judged that indoor fan protection occurs

Possible reason:

- Motor stops operation or it is blocked
- IDU mainboard is abnormal;

Troubleshooting:

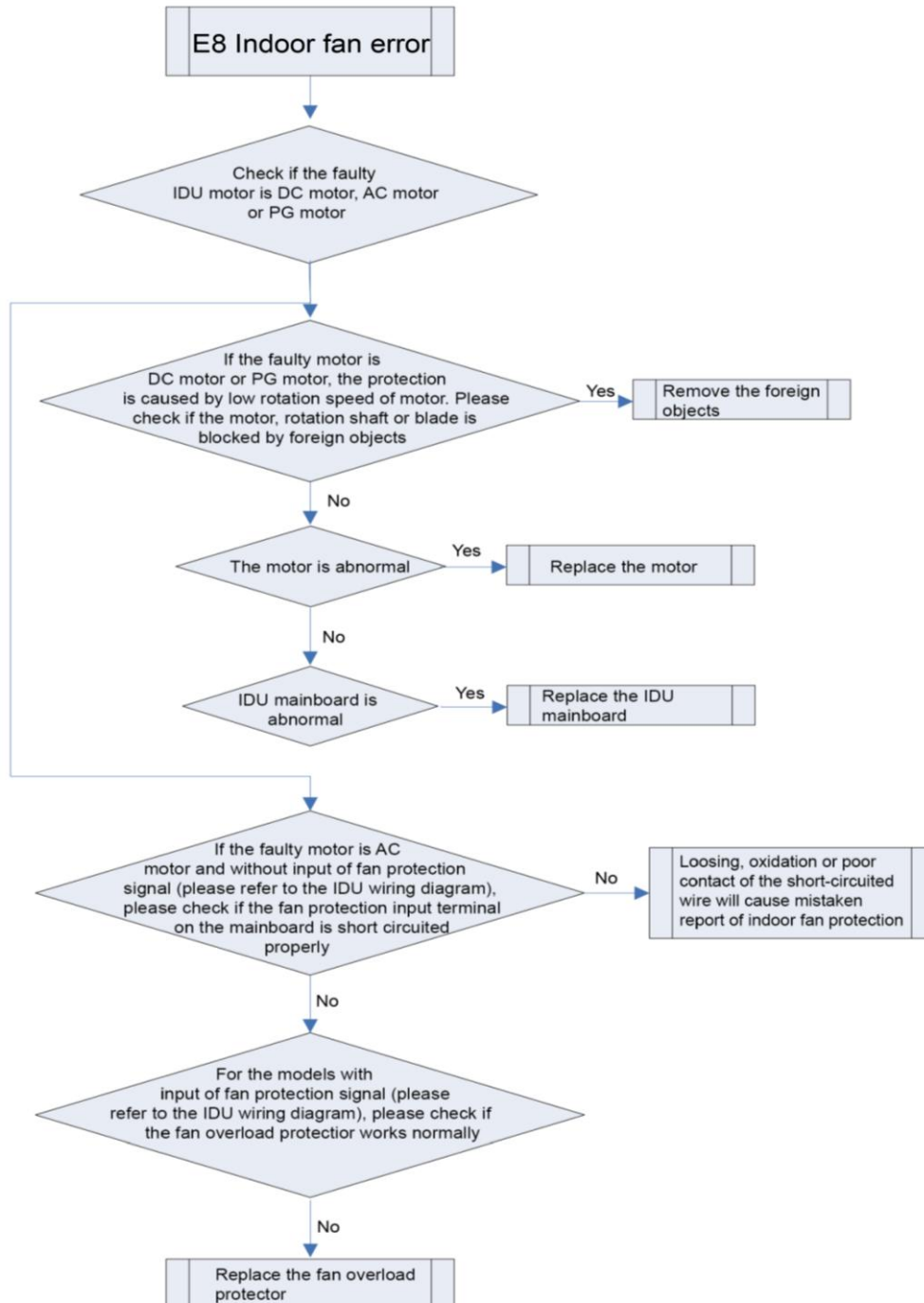

3.4.7 “E9” Water Overflow Protection

Error display: IDU wired control and IDU receiver light board will display **E9**

Error judgment condition and method:

Check the status of IDU float switch. When water level is too high, float switch is activated, so water full protection happens.

Possible reason:

- IDU is installed improperly
- Drainage pump is broken
- Float switch operates abnormally
- IDU mainboard is abnormal;

Troubleshooting:

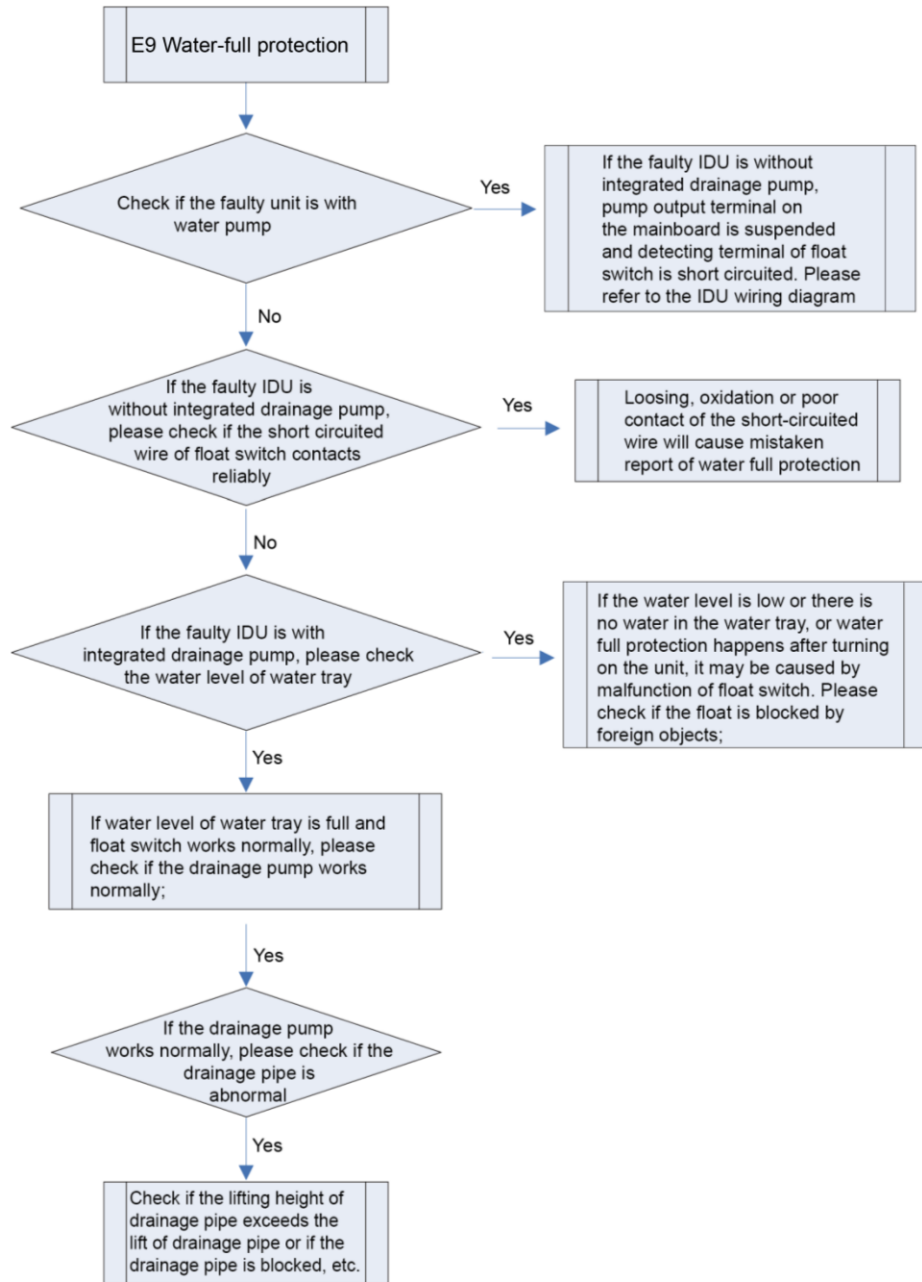

3.4.8 “F0” Indoor Ambient Temperature Sensor Error

Error display: IDU wired control and IDU receiver light board will display **F0**

Error judgment condition and method:

Sample the AD value of temperature sensor through temperature sensor detecting circuit and judge the range of AD value, If the sampling AD value exceeds upper limit and lower limit in 5 seconds continuously, report the error.

Possible reason:

- Poor contact between ambient temperature sensor and terminal in mainboard interface
- Ambient temperature sensor is abnormal
- Detecting circuit is abnormal

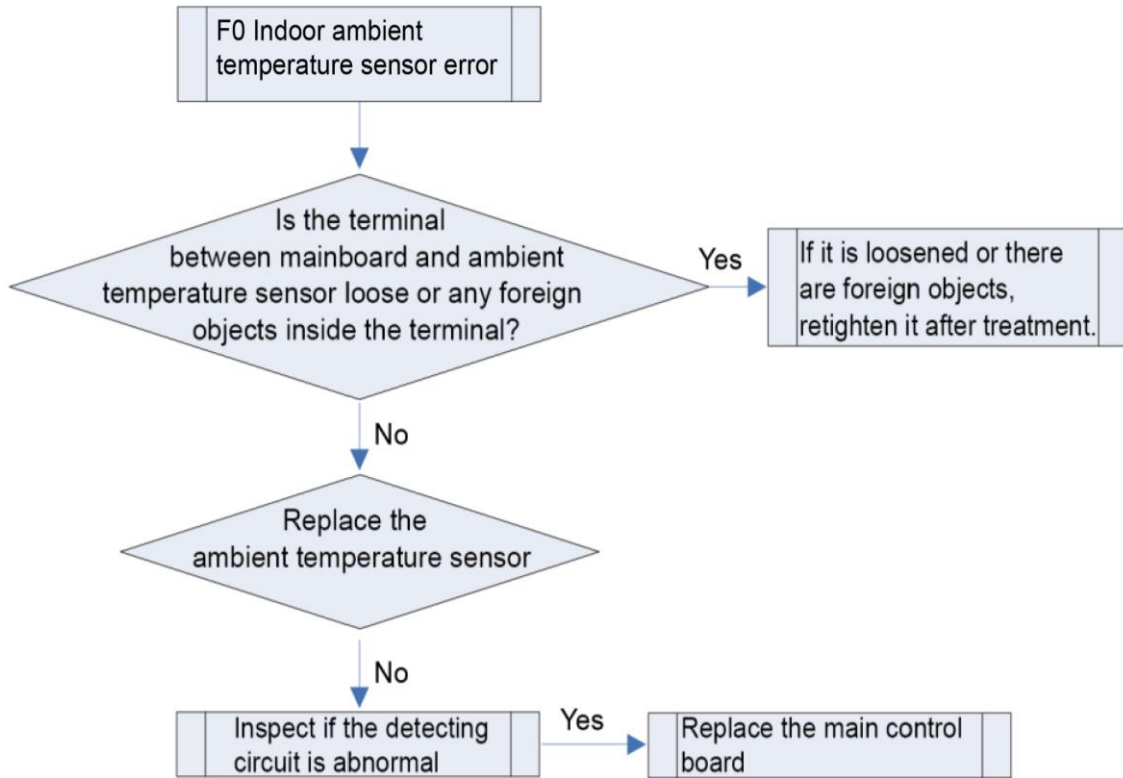
Troubleshooting:

3.4.9 “F1” Evaporator Temperature Sensor Error

Error display: IDU wired control and IDU receiver light board will display **F1**

Error judgment condition and method:

Sample the AD value of temperature sensor through temperature sensor detecting circuit and judge the range of AD value, If the sampling AD value exceeds upper limit and lower limit in 5 seconds continuously, report the error.

Possible reason:

- Poor contact between temperature sensor and terminal in mainboard interface
- Temperature sensor is abnormal
- Detecting circuit is abnormal

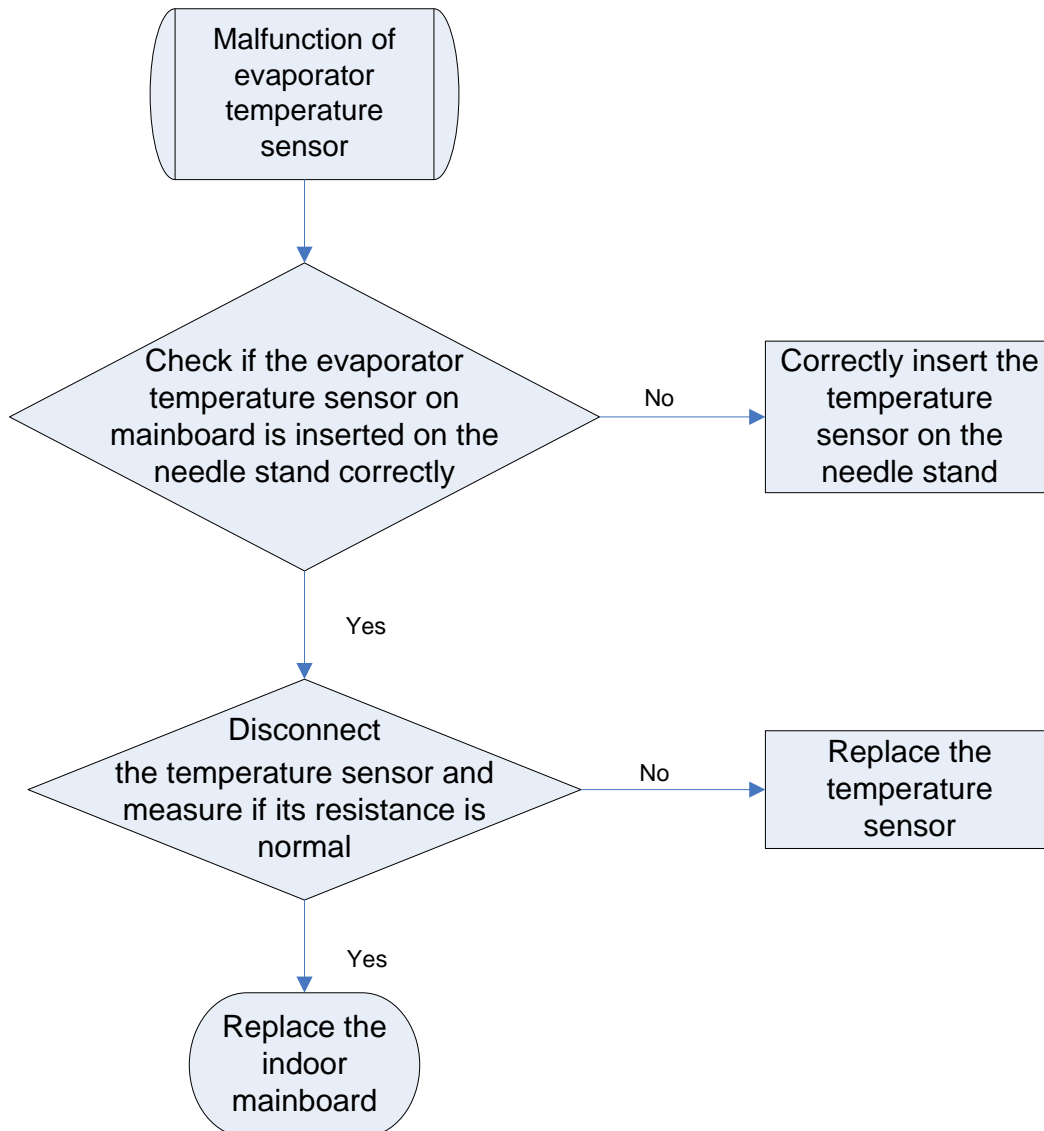
Troubleshooting:

Note: Please refer to Appendix 1 for the relation between temperature and resistance of temperature sensor.

3.4.10 "F2" Condenser Temperature Sensor Error

Error display: ODU mainboard, IDU wired control and IDU receiver light board will display: **F2**

Error judgment condition and method:

Sample the AD value of temperature sensor through temperature sensor detecting circuit and judge the range of AD value, If the sampling AD value exceeds upper limit and lower limit in 5 seconds continuously, report the error.

Possible reason:

- Poor contact between temperature sensor and terminal in mainboard interface
- Temperature sensor is abnormal
- Detecting circuit is abnormal

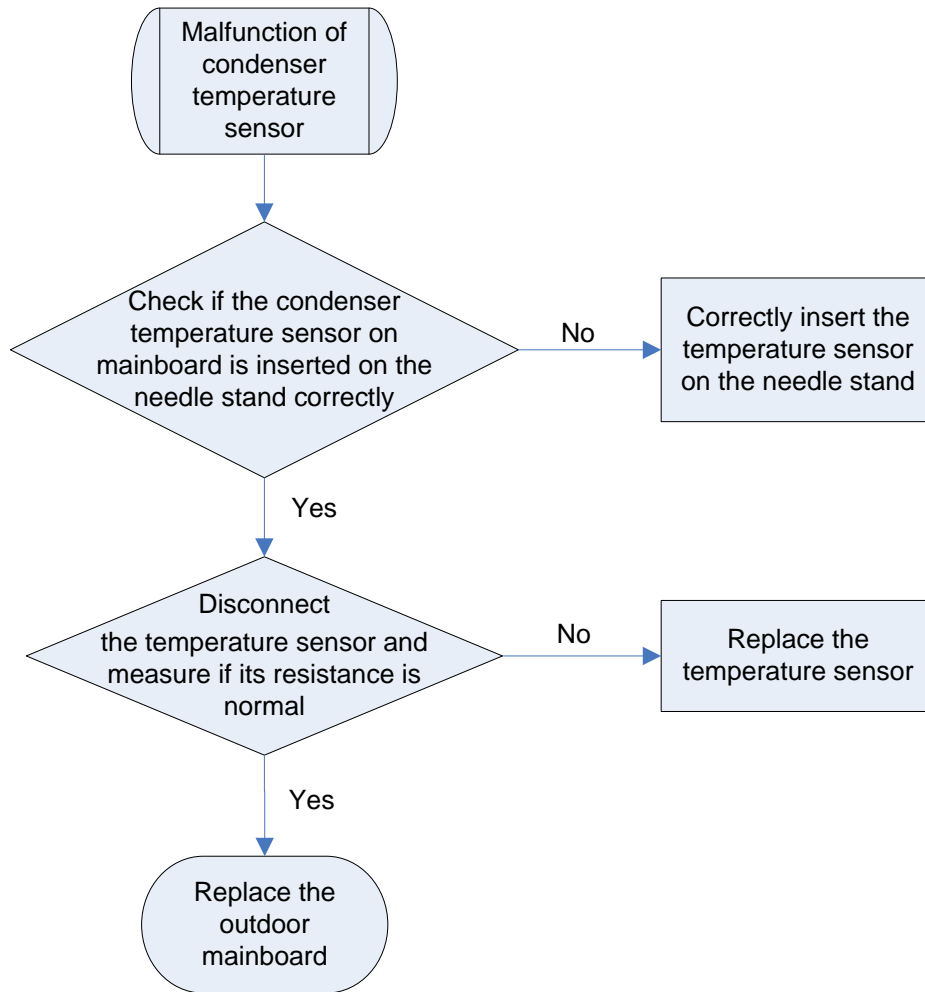
Troubleshooting:

Note: Please refer to Appendix 1 for the relation between temperature and resistance of temperature sensor.

3.4.11 “F3” Outdoor Ambient Temperature Sensor Error

Error display: ODU mainboard, IDU wired control and IDU receiver light board will display: **F3**

Error judgment condition and method:

Sample the AD value of temperature sensor through temperature sensor detecting circuit and judge the range of AD value, If the sampling AD value exceeds upper limit and lower limit in 5 seconds continuously, report the error.

Possible reason:

- Poor contact between ambient temperature sensor and terminal in mainboard interface
- Ambient temperature sensor is abnormal
- Detecting circuit is abnormal

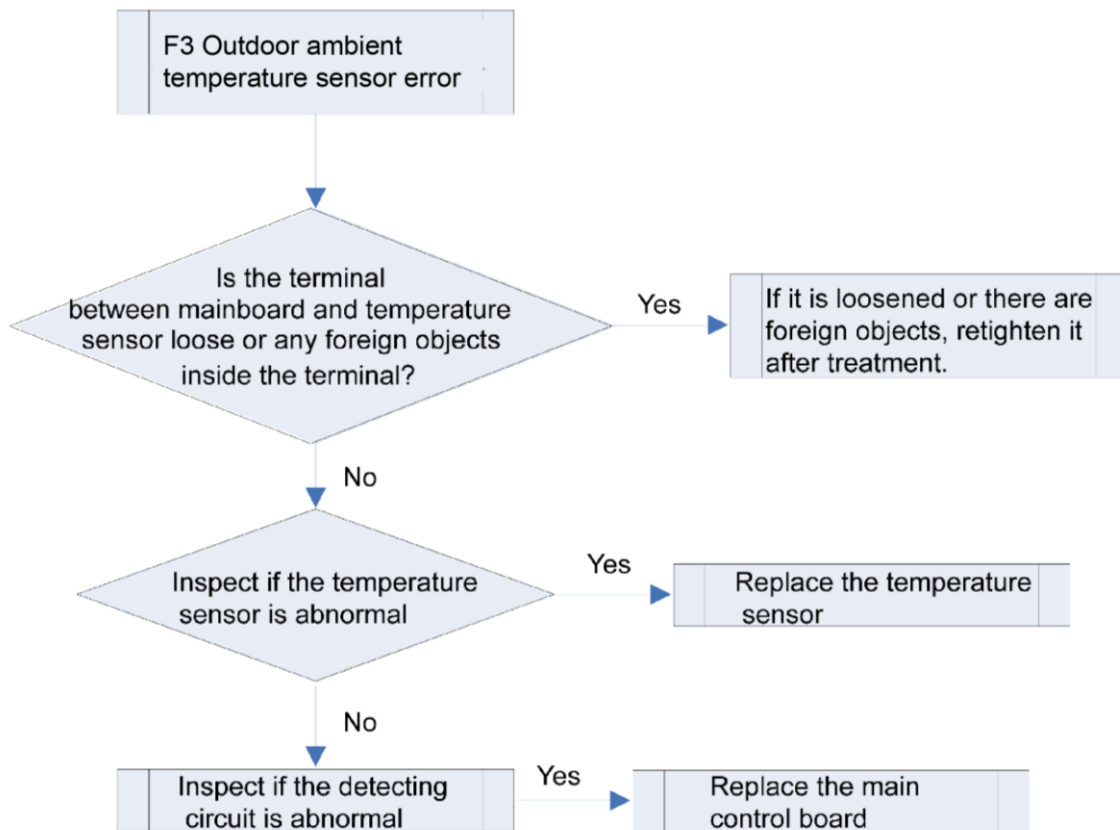
Troubleshooting:

Note: Please refer to Appendix 1 for the relation between temperature and resistance of temperature sensor.

3.4.12 “F4” Discharge Temperature Sensor Error

Error display: ODU mainboard, IDU wired control and IDU receiver light board will display **F4**

Error judgment condition and method:

Sample the AD value of temperature sensor through temperature sensor detecting circuit and judge the range of AD value, If the sampling AD value exceeds upper limit and lower limit in 5 seconds continuously, report the error.

Possible reason:

- Poor contact between temperature sensor and terminal in mainboard interface
- Temperature sensor is abnormal
- Detecting circuit is abnormal

Troubleshooting:

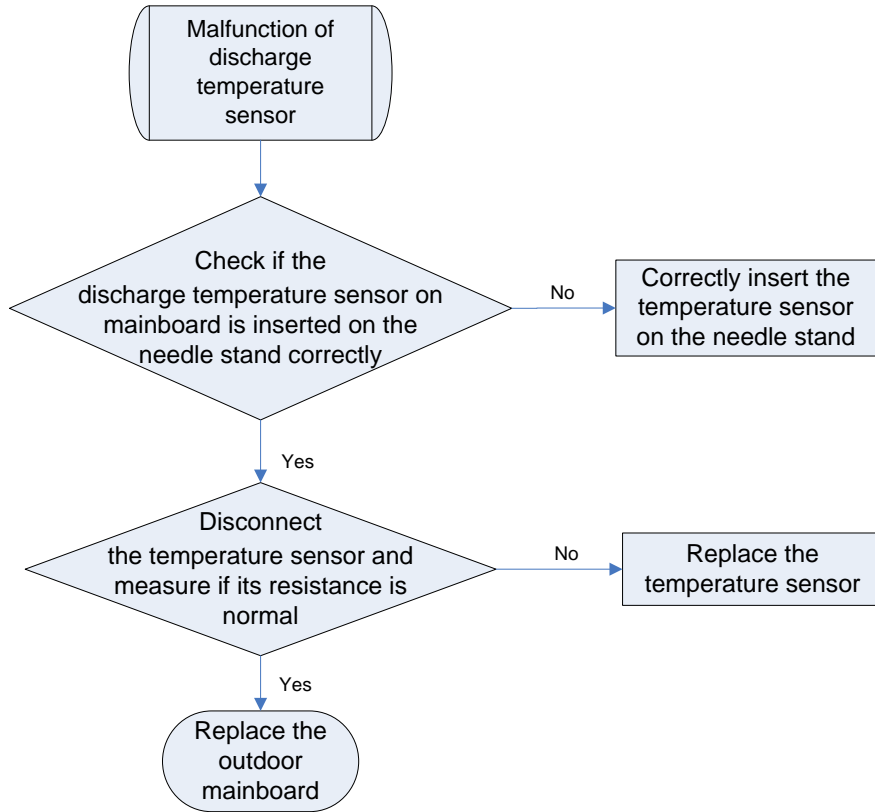

Note: Please refer to Appendix 1 for the relation between temperature and resistance of temperature sensor.

3.4.13 “F5” Wired Control Temperature Sensor Error

Error display: IDU wired control and IDU receiver light board will display **F5**

Error judgment condition and method:

Sample the AD value of temperature sensor through temperature sensor detecting circuit and judge the range of AD value, If the sampling AD value exceeds upper limit and lower limit in 5 seconds continuously, report the error.

Possible reason:

- Poor contact between temperature sensor and terminal in mainboard interface
- Temperature sensor is abnormal
- Detecting circuit is abnormal

Troubleshooting:

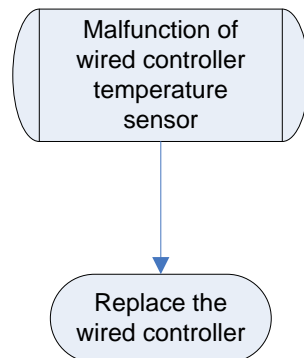

3.4.14 “C5” IDU Jumper Cap Error

Error display: IDU wired control and IDU receiver light board will display **C5**

Error judgment condition and method:

If jumper cap model doesn't match with mainboard, this error will be reported.

Possible reason:

- Jumper cap is not installed.
- Jumper cap model is wrong.
- Detecting circuit is abnormal.

Troubleshooting:

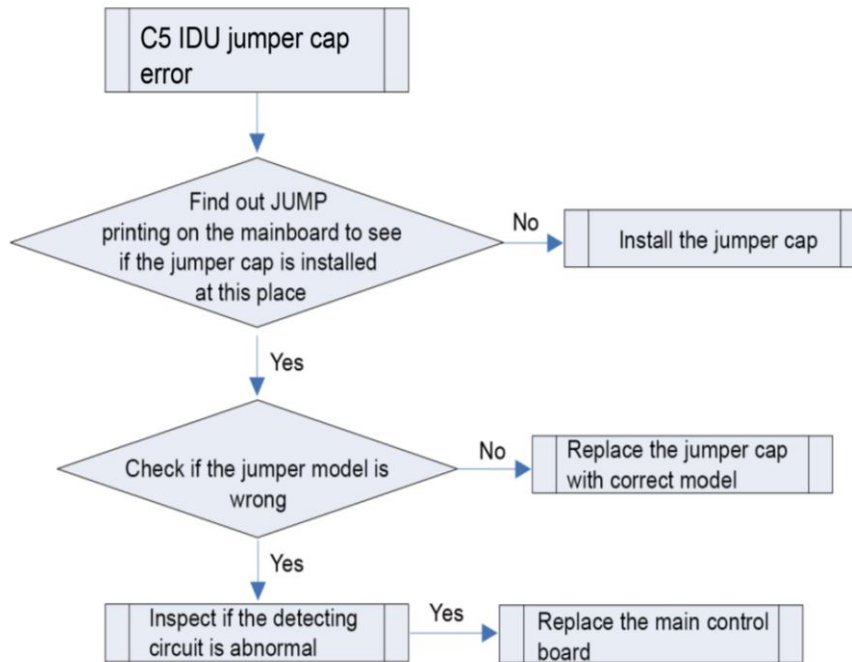

3.4.15 “EE” IDU or ODU Memory Chip Error

Error display: IDU wired control, IDU and ODU receiver light board will display **EE**

Error judgment condition and method:

If ODU mainboard cannot read the memory chip, this error will be reported.

Possible reason:

- Memory chip on the ODU mainboard is damaged.
- Memory chip is weakly welded.
- Memory chip lead is short-circuited.

Troubleshooting:

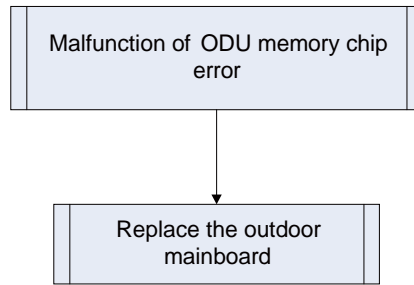

3.4.16 “PF” Electric Box Sensor Error

Error display: ODU mainboard, IDU wired controller **PF**

Error judgment condition and method:

Sample the AD value of temperature sensor through temperature sensor detecting circuit and judge the range of AD value, If the sampling AD value exceeds upper limit and lower limit in 5 seconds continuously, report the error.

Possible reason:

- Poor contact between temperature sensor and terminal in mainboard interface
- Temperature sensor is abnormal
- Detecting circuit is abnormal

Troubleshooting:

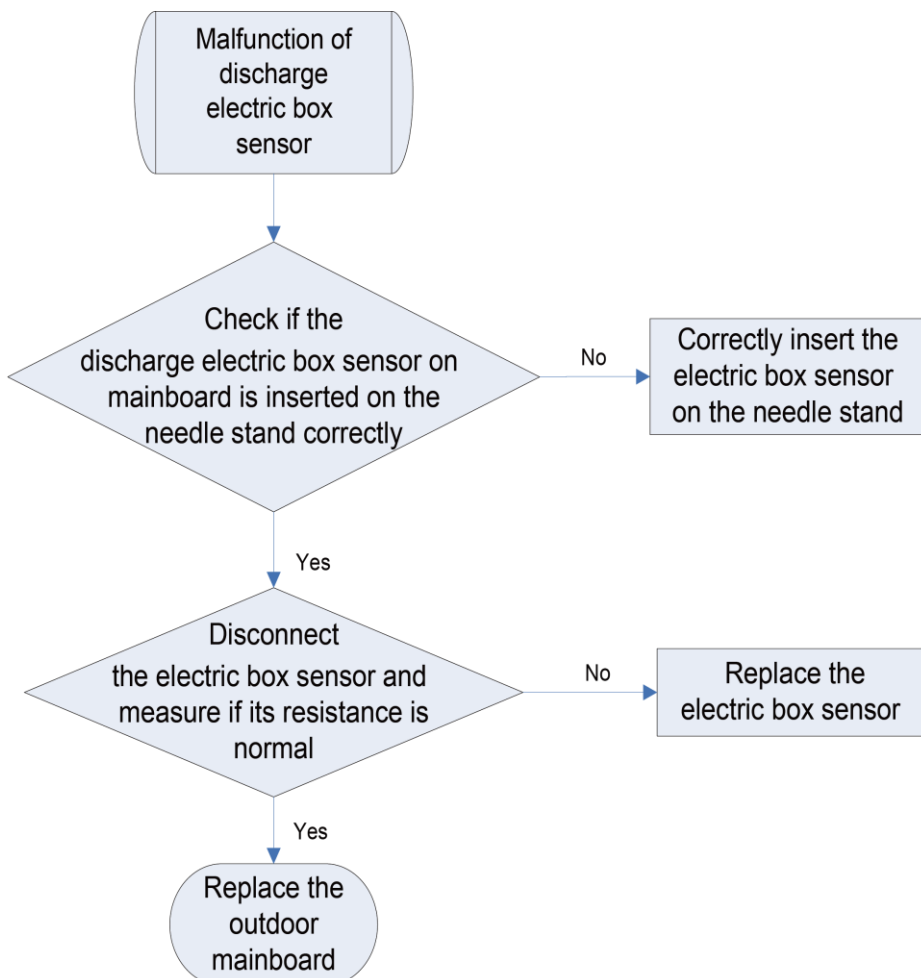

Note: Please refer to Appendix 1 for the relation between temperature and resistance of temperature sensor.

3.4.17 “H3” Compressor Overload Protection

Error display: ODU mainboard, IDU wired control and IDU receiver light board will display **H3**

Error judgment condition and method:

When the mainboard’s interface ovc-comp is broken off for 3s, error H3 will be reported.

Possible reason:

- The interface ovc-comp is not short-circuited.
- ODU mainboard is damaged.

Troubleshooting:

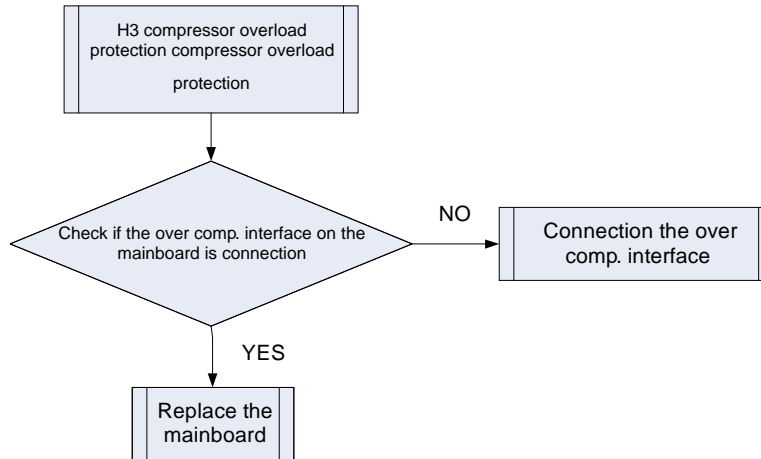

3.4.18 “H4” Overload

Error display: ODU mainboard, IDU wired control and IDU receiver light board will display **H4**

Error judgment condition and method:

When tube temperature is higher than the protection value, system will report overload protection.

Possible reason:

- Cooling ODU heat exchanger is blocked or heat exchange is bad.
- Heating IDU heat exchanger is blocked or heat exchange is bad.
- Operating temperature is too high.
- System charging quantity is too much.

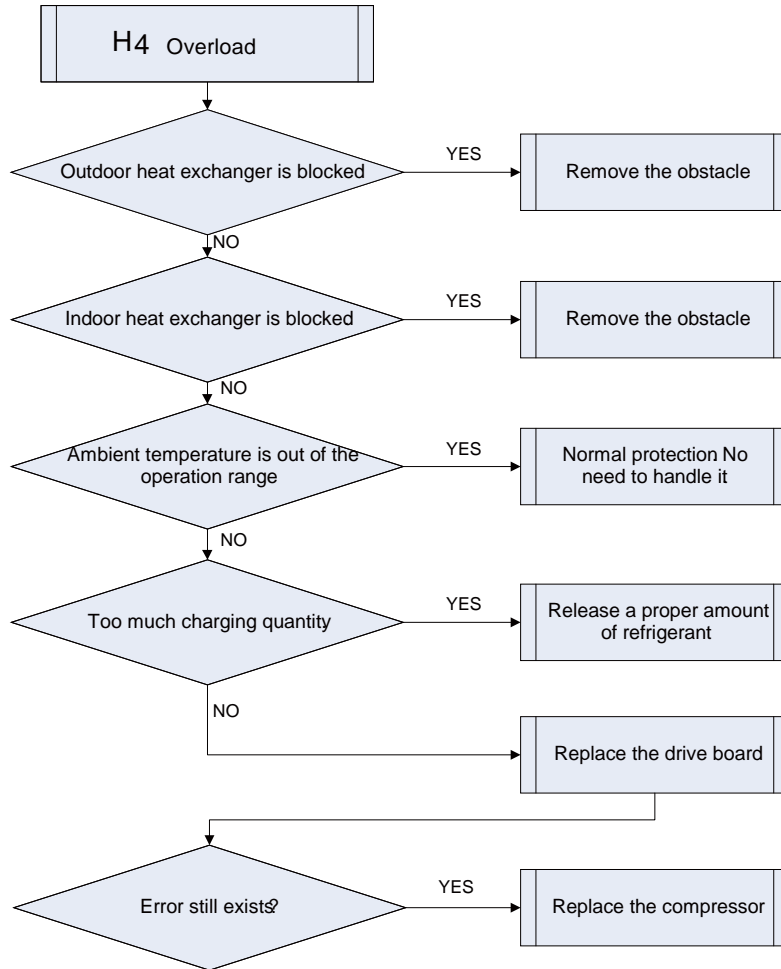
Troubleshooting:

3.4.19 “H5” IPM Protection

Error display: ODU mainboard, IDU wired control and IDU receiver light board will display **H5**

Error judgment condition and method:

When power is connected and drive chip received IPM lead F0 that is of low level, than it is IPM module malfunction. System will shut down for protection.

Possible reason:

- Compressor 3-phase wire connection is lack of phase or phase-reversed.
- System is overloaded and compressor current is too large.
- Drive board IPM module is damaged.
- Drive board IPM module’s 15V power supply is lower than 13.5V.
- Drive board 6-line PWM signal and the corresponding element are abnormal.
- Drive board compressor current sampling circuit element is damaged or drive chip current sampling AD terminal is abnormal.
- Compressor is damaged.

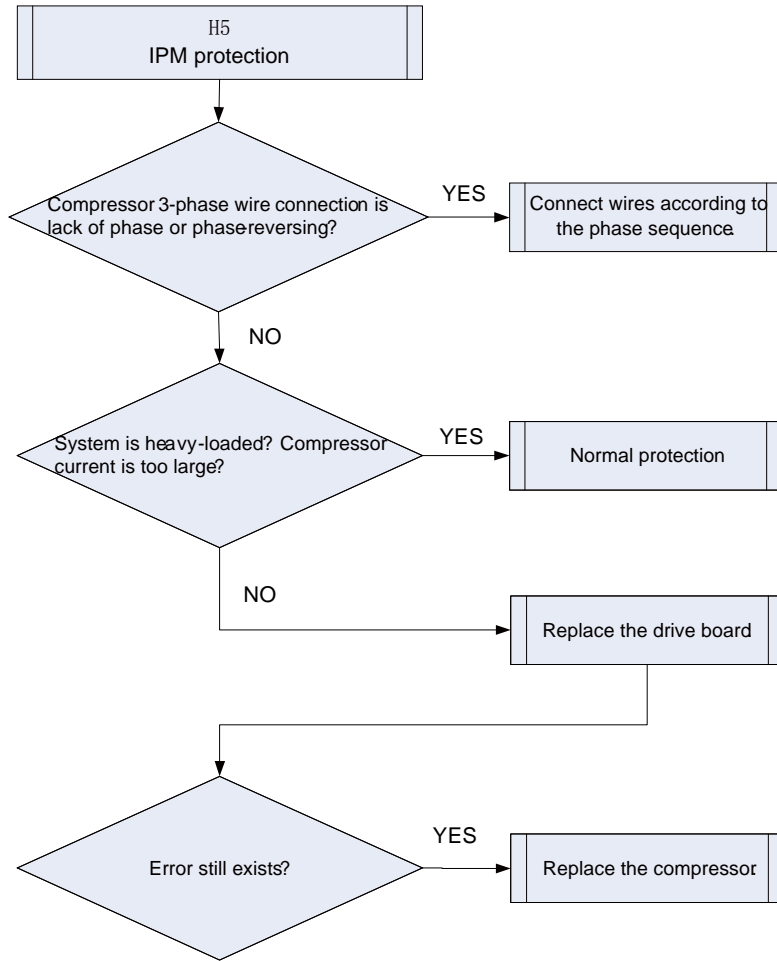
Troubleshooting:

3.4.20 "H6" DC Fan Error

Error display: ODU mainboard, IDU wired control and IDU receiver light board will display **H6**

Error judgment condition and method:

Mainboard doesn't receive the signal of outdoor fan within 30s after the outdoor fan starts up.

Possible reason:

- Outdoor fan wiring terminal is not correctly connected to the mainboard.
- Outdoor fan is damaged.
- If it is a new unit or a new motor has been replaced in the unit and the wire connection is correct, then probably it is the program that goes wrong.

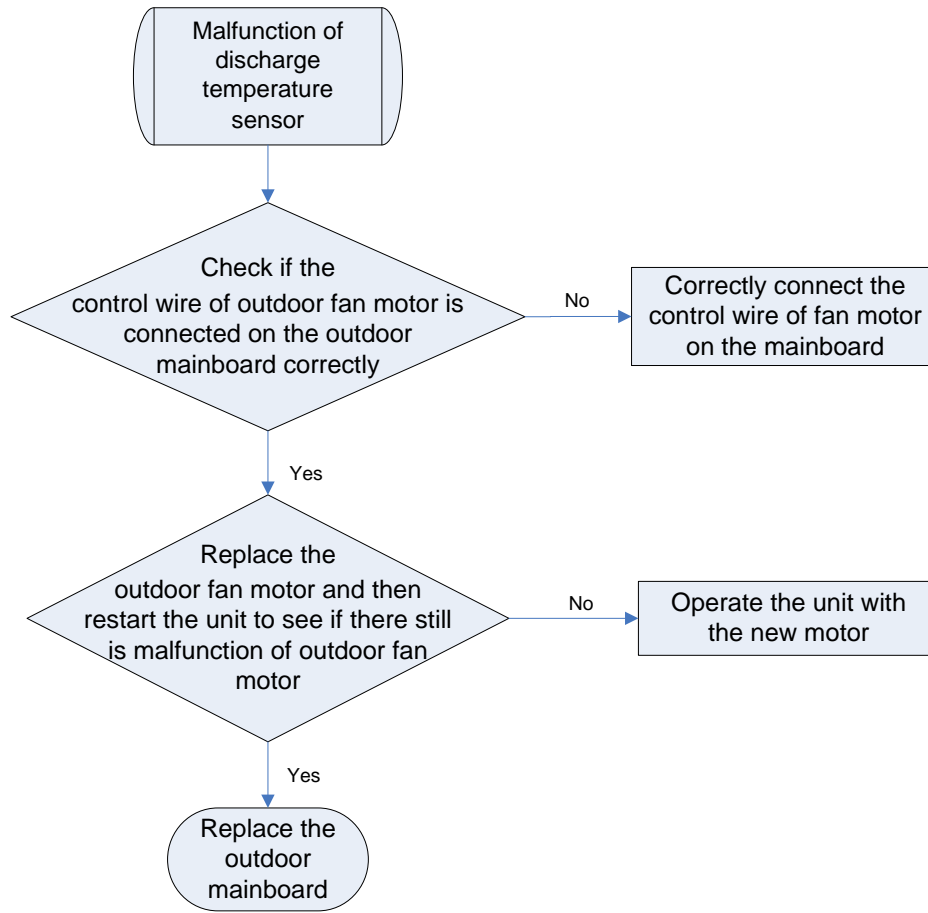
Troubleshooting:

3.4.21 “H7” Driver Out-of-Step Protection

Error display: ODU mainboard, IDU wired control and IDU receiver light board will display **H7**

Error judgment condition and method:

During operation, it can't detect the rotor position and stops output. Or the actual running speed differs too much from the set running speed. In each case, compressor runs out of step and system stops for protection.

Possible reason:

- Compressor 3-phase wire connection is lack of phase or phased-reversed.
- Compressor phase wire connection is bad.
- System is blocked, short of refrigerant or compressor oil.
- Drive board IPM module is damaged.
- Drive board compressor current sampling circuit element is damaged or drive chip current sampling AD terminal is abnormal.
- Compressor is damaged.

Troubleshooting:

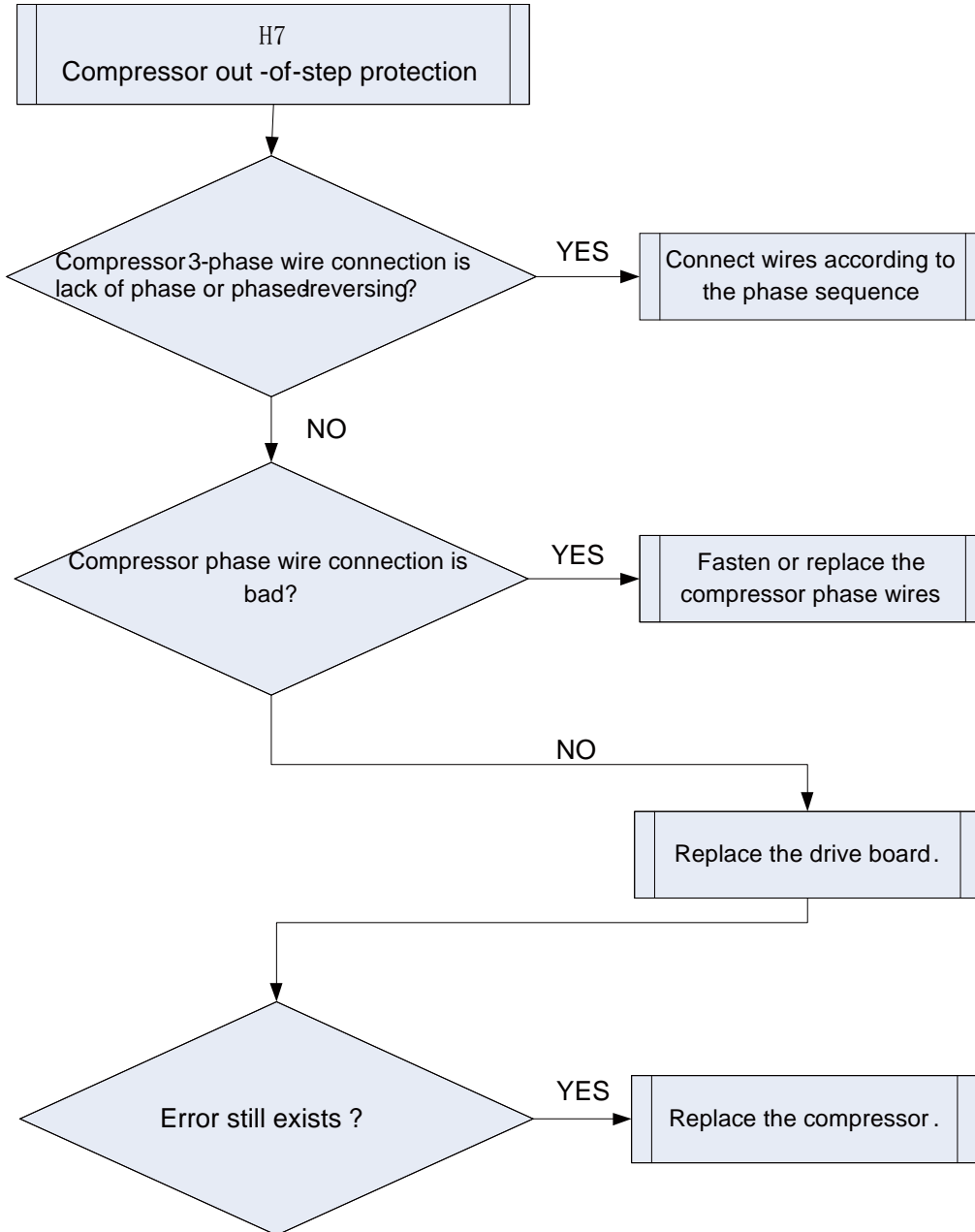

3.4.22 “HC” PFC Protection

Error display: ODU mainboard, IDU wired control and IDU receiver light board will display **HC**

Error judgment condition and method:

After power is connected, and drive chip received IPM lead F0 that is of low level, then it is IPM module malfunction. System will shut down for protection.

Possible reason:

- Power grid voltage is abnormal.
- Drive board PFC module is damaged.
- Drive board IPM module's 15V power supply is lower than 13.5V.
- Drive board PWM signal for PFC and the corresponding element are abnormal.
- Drive board PFC current sampling circuit element is damaged or drive chip current sampling AD terminal is abnormal.

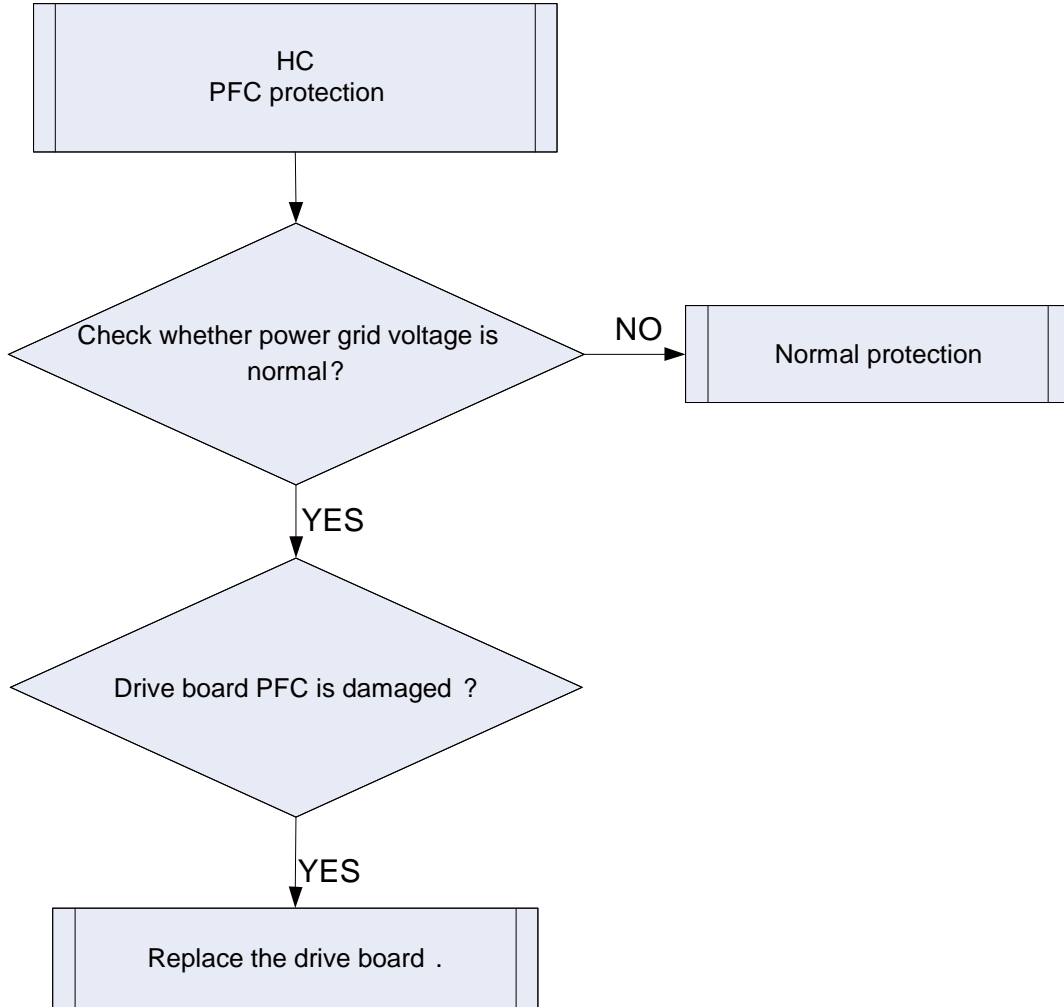
Troubleshooting:

3.4.23 "Lc" Startup Failure

Error display: ODU mainboard, IDU wired controller and IDU receive light board will display **Lc**

Error judgment condition and method:

Check the error code on nixie tube of ODU main control board. If PJ is displayed, it indicates inverter compressor startup failure

Possible reason:

- Poor contact of compressor UVW wire;
- Compressor is broken;
- Compressor drive board is broken;

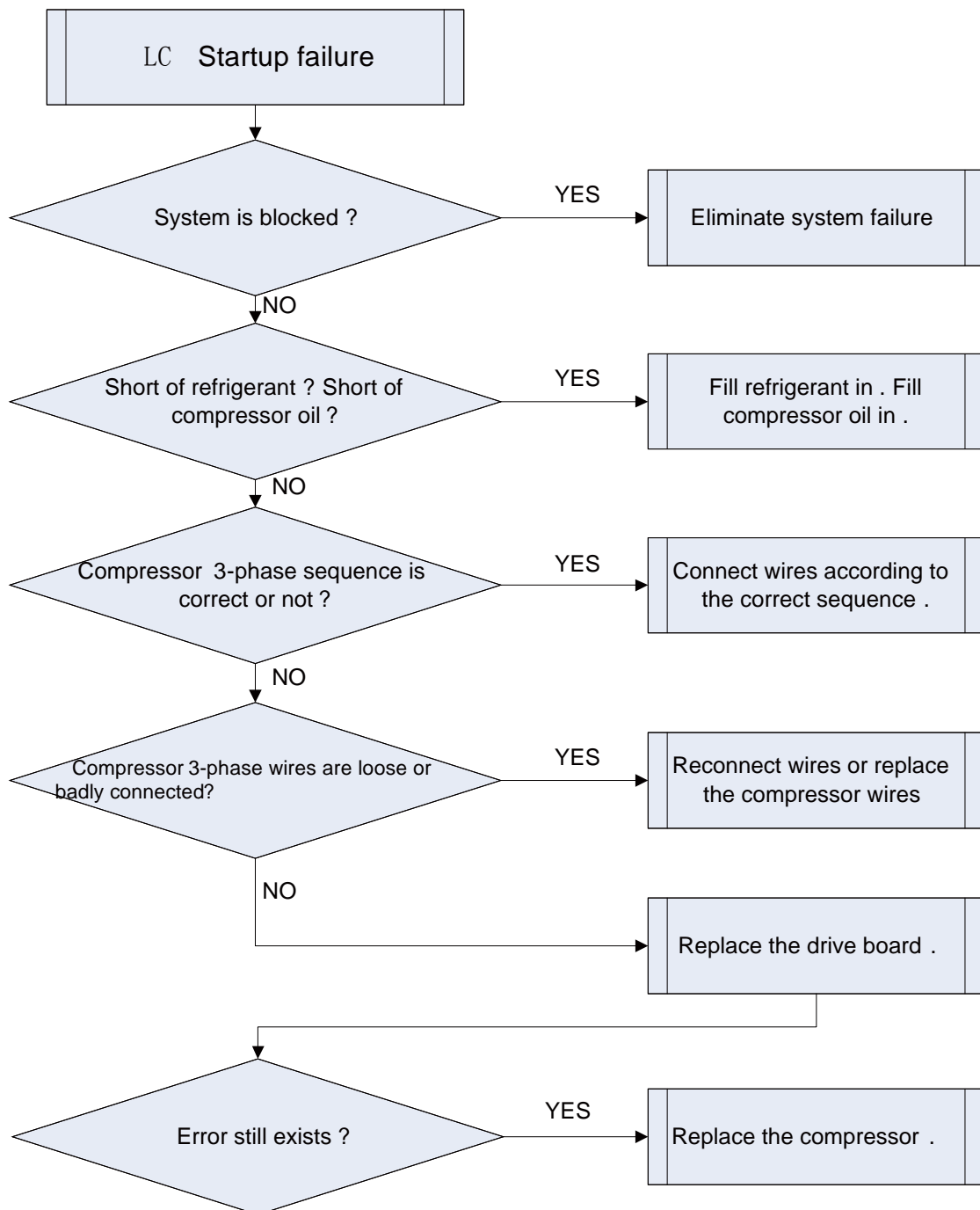
Troubleshooting:

3.4.24 “Lp” IDU and ODU Unmatched

Error display: ODU mainboard, IDU wired control and IDU receiver light board will display **Lp**

Error judgment condition and method: /

Possible reason:

■ Models of indoor unit and outdoor unit do not match with each other

Troubleshooting:

Turn off the unit and replace with a matched indoor or outdoor unit.

3.4.25 “U7” 4–Way Valve Switch-Over Error

Error display: ODU mainboard, IDU wired control and IDU receiver light board will display **U7**

Error judgment condition and method:

Possible reason:

- Voltage is abnormal. For example, low voltage will cause abnormal direction change of the 4-way valve.
- Pilot valve holder hole or the capillary tube is blocked, which has caused small flow or no flow.
- Capillary tube is blocked when connecting to the pilot valve or main valve.
- Coil is not power-connected, or is open-circuited. Voltage is low, or the contact between turns or terminals is bad.
- The stainless steel cover of pilot valve is damaged, or the steel core is stuck, or the spring is not elastic.
- Insert block is bent or not elastic, so the little slide cannot get in place.
- When adding refrigerant, the little slide is over-running and can't spring back.

Troubleshooting:

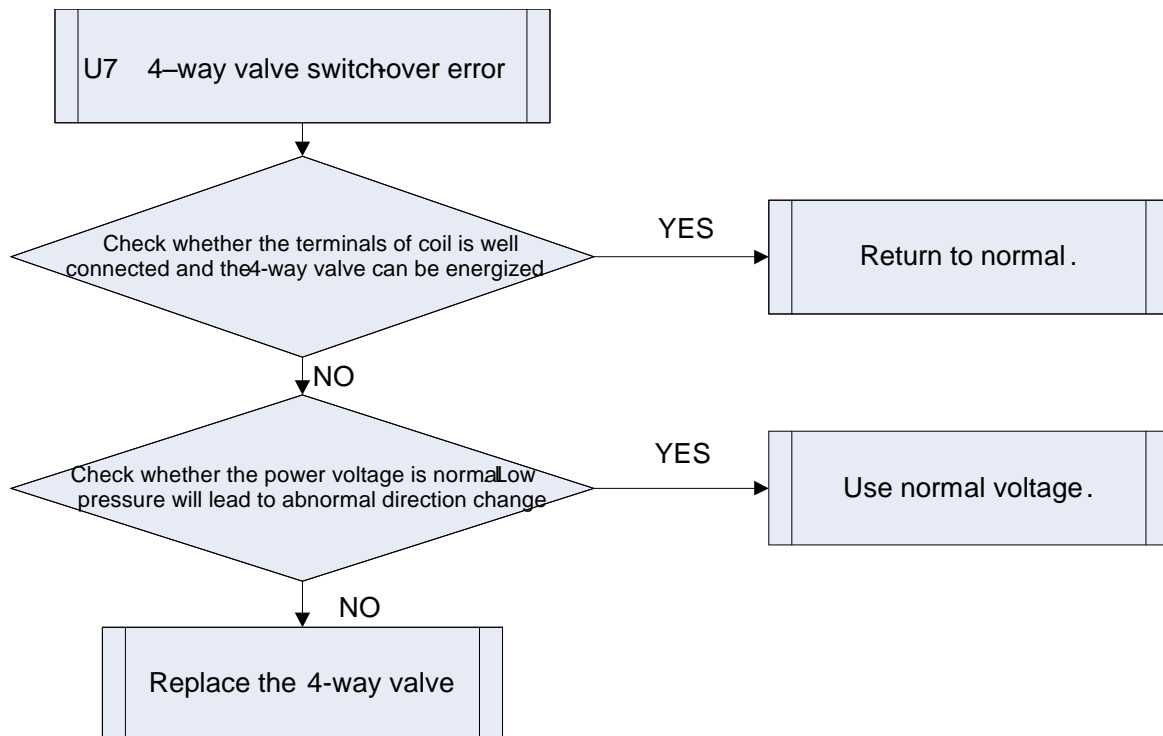

3.4.26 “P0” Driver Reset Protection

Error display: ODU mainboard, IDU wired control and IDU receiver light board will display **P0**

Error judgment condition and method:

Drive board chip resets and starts initialization. After the drive board is energized for 5s, it detects that the chip resets again. In this case, it can be judged as drive chip reset protection.

Possible reason:

- 3.3V drive chip supply voltage drop.
- TRST lead of JTAG programming is interrupted.

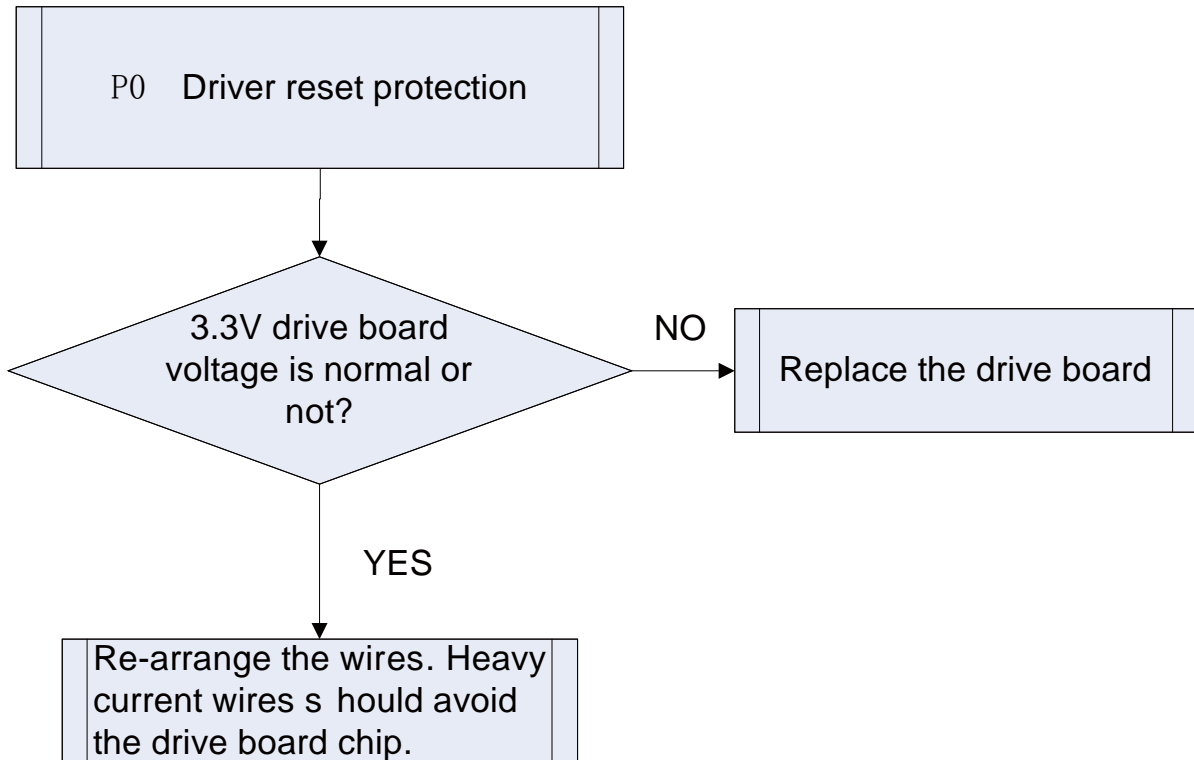
Troubleshooting:

3.4.27 “P5” Over-Current Protection

Error display: ODU mainboard, IDU wired control and IDU receiver light board will display **P5**

Error judgment condition and method:

If compressor’s instant current value is higher than the set current protection value, then it can be judged that compressor over-current occurs and system will shut down for protection.

Possible reason:

- System load is too much and compressor current is too large.
- Compressor 3-phase wire connection is lack of phase or phase-reversed.
- Compressor phase wire is loose or has bad contact.
- Drive board current sampling circuit element is damaged or drive chip current sampling AD terminal is abnormal.
- Compressor is damaged.

Troubleshooting:

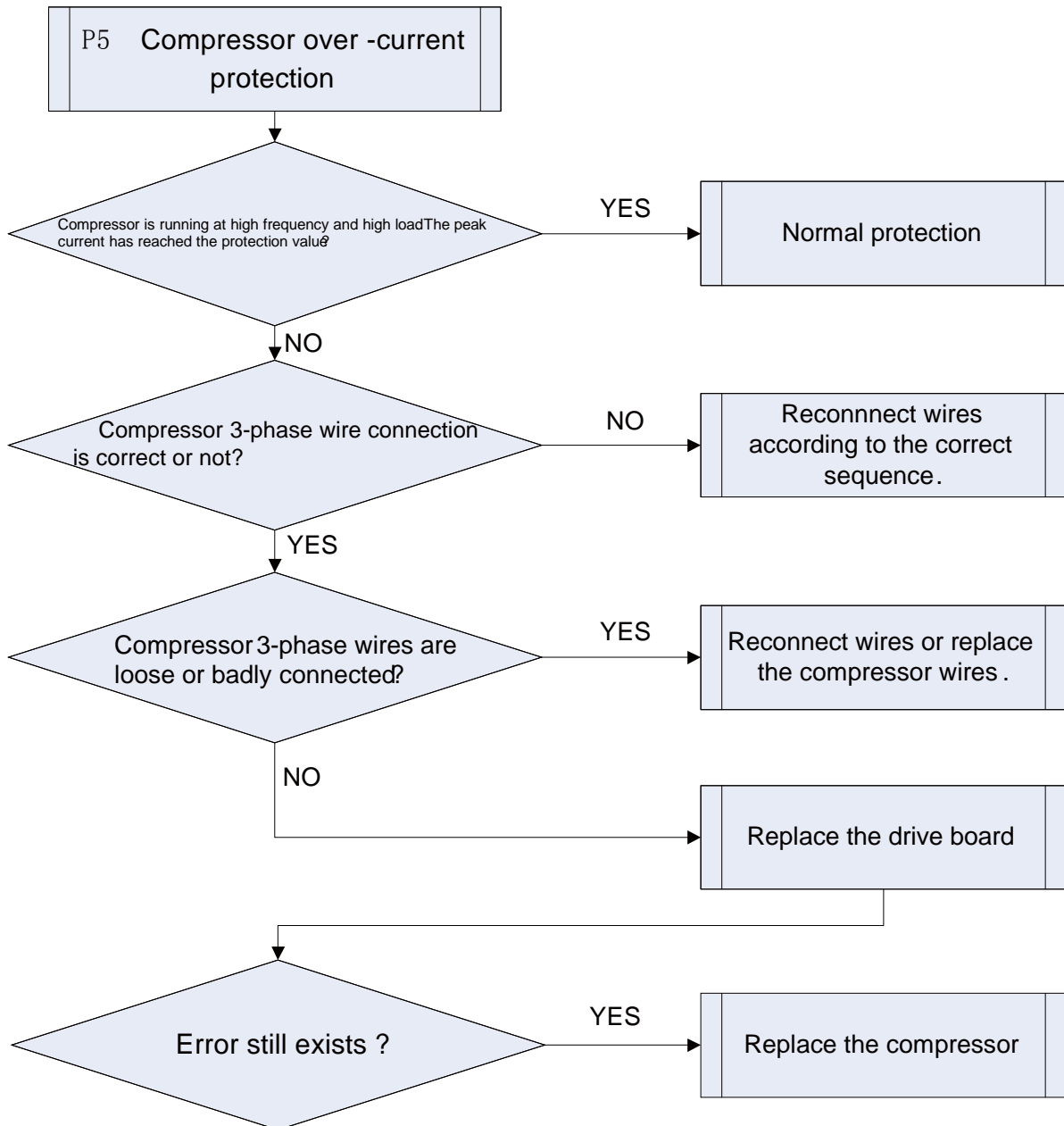

3.4.28 “P6” Master Control and Driver Communication Error

Error display: ODU mainboard, IDU wired control and IDU receiver light board will display **P6**

Error judgment condition and method:

If there is no other malfunction and the communication between master control and driver is cut off for 30s, then it can be judged that the communication between master control and driver is faulted. System will shut down for protection.

Possible reason:

- Communication wire between master control and driver is not well connected, or has bad contact, or is broken.
- The switch power of drive board is abnormal, therefore, the 3.3V power voltage is abnormal.
- Communication circuit of the drive board or the master control board is abnormal.

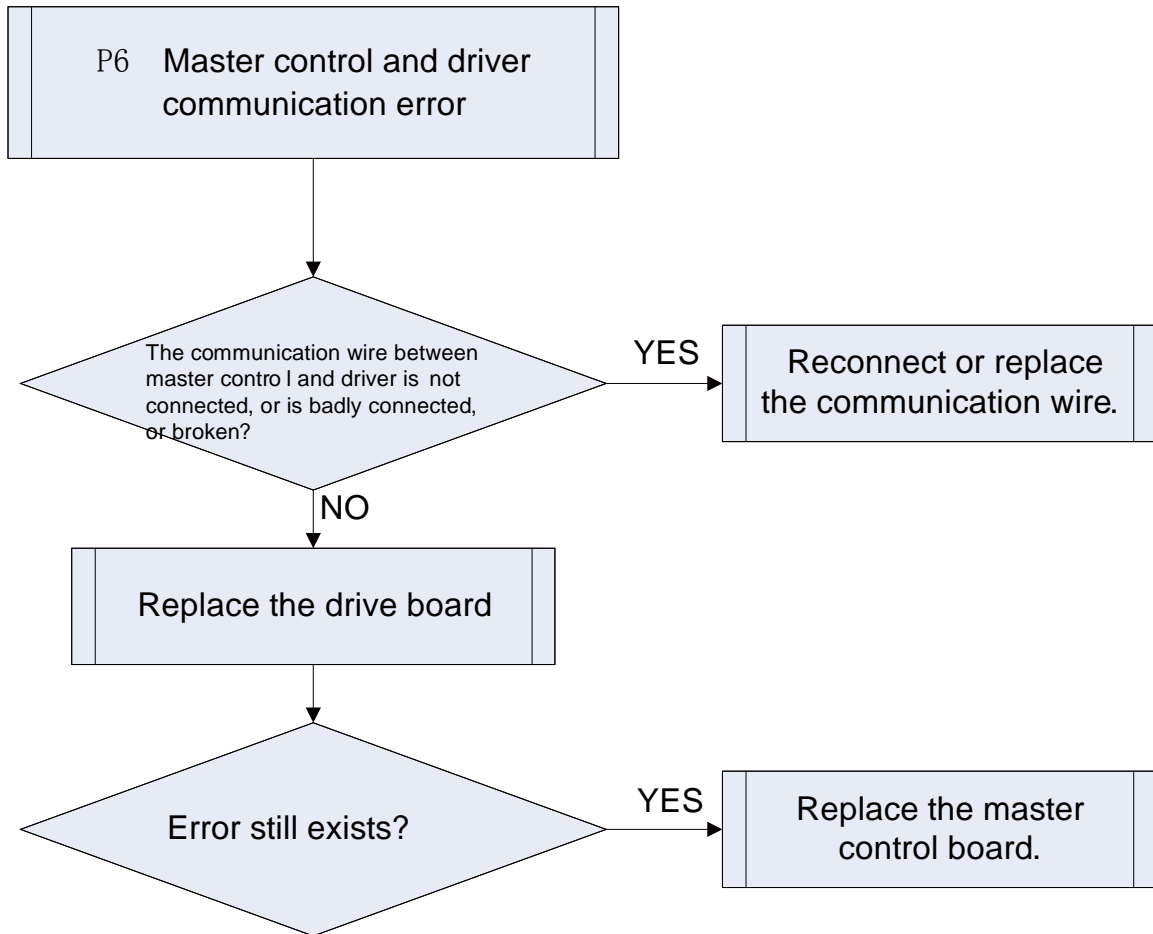
Troubleshooting:

3.4.29 “P7” Driver Module Sensor Error

Error display: ODU mainboard, IDU wired control and IDU receiver light board will display **P7**

Error judgment condition and method:

If IPM or PFC module temperature is lower than the set protection value, then it can be judged that driver module sensor error occurs and system will shut down for protection.

Possible reason:

- Module temperature sensor is short-circuited or broken-circuited.
- Drive board current sampling circuit element is damaged or drive chip current sampling AD terminal is abnormal.

Troubleshooting:

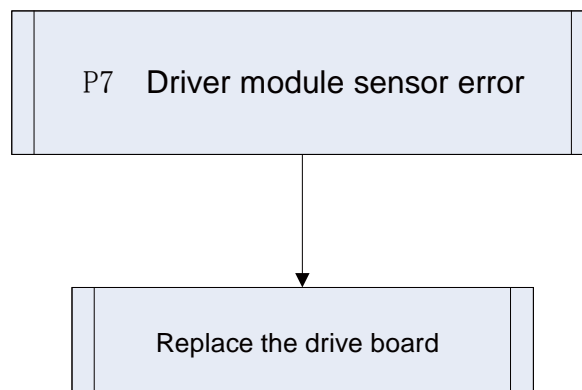

3.4.30 “P8” Driver Module High Temperature Protection

Error display: ODU mainboard, IDU wired control and IDU receiver light board will display **P8**

Error judgment condition and method:

If IPM module temperature or PFC module temperature exceeds the set protection value, then it can be judged that driver module temperature is too high and system will shut down for protection.

Possible reason:

- Thermal grease is not applied or not evenly applied to the module, or there is other substance on the back of the module.
- The module securing screws are not tightened up.
- Drive board temperature sampling circuit element is damaged or drive chip temperature sampling AD terminal is abnormal.

Troubleshooting:

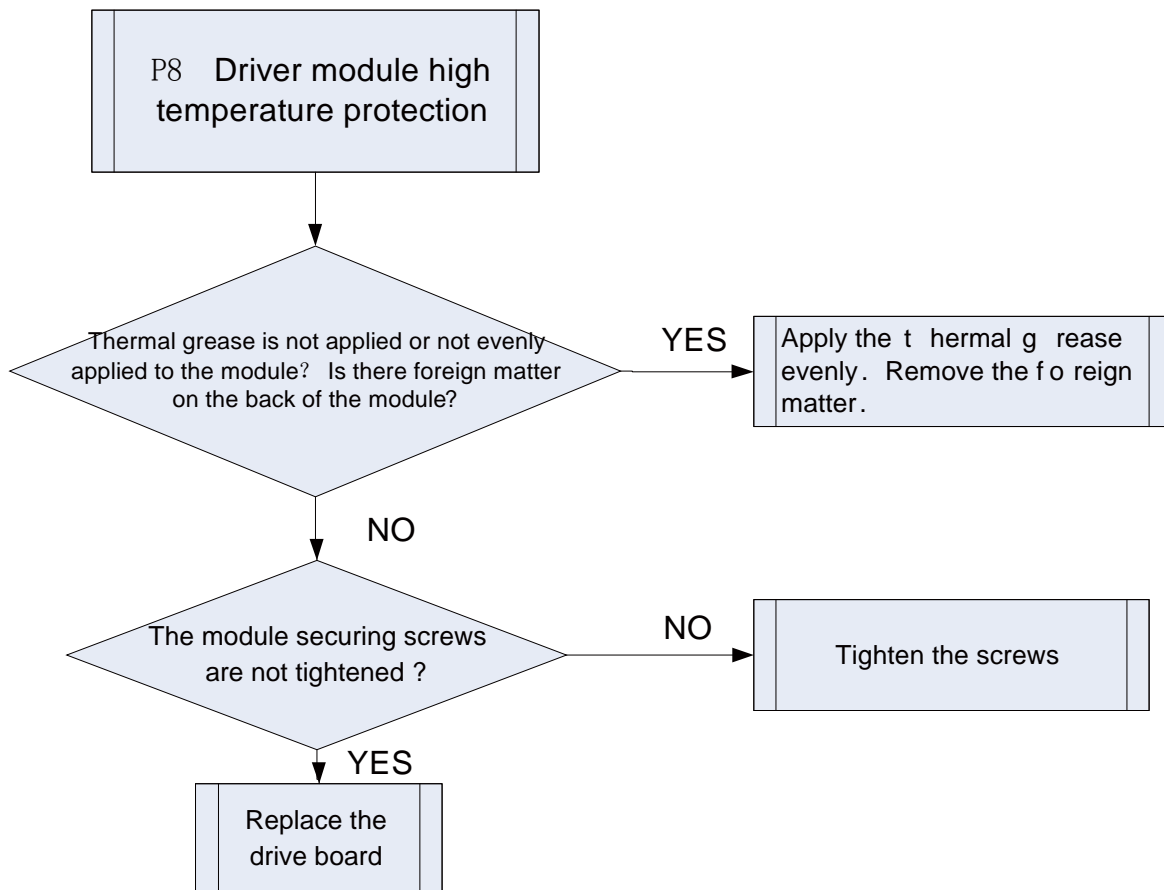

3.4.31 “PA” AC Current Protection

Error display: ODU mainboard, IDU wired control and IDU receiver light board will display **PA**

Error judgment condition and method:

If input current value exceeds the set protection value, then it can be judged that AC current protection occurs and system will shut down for protection.

Possible reason:

- System is heavy-loaded and compressor current is too large.
- Grid voltage is abnormal.

■PFC module is damaged.

■Drive board PFC current sampling circuit element is damaged or drive chip PFC current sampling AD terminal is abnormal.

Troubleshooting:

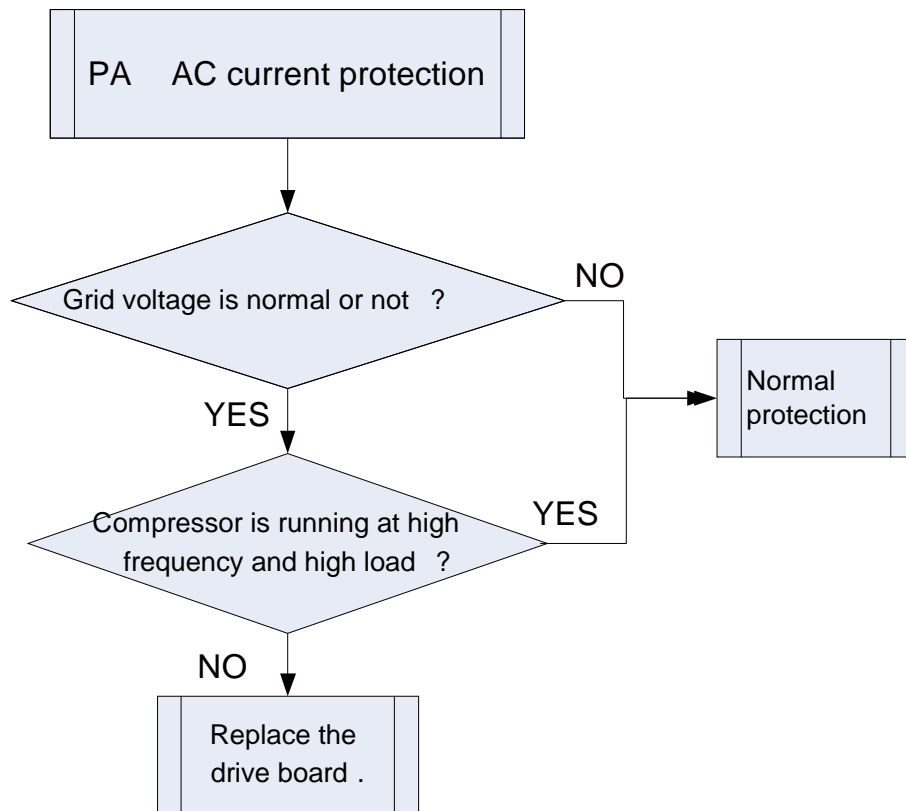

3.4.32 "Pc" Driver Current Error

Error display: ODU mainboard, IDU wired control and IDU receiver light board will display **PC**

Error judgment condition and method:

After power charging, if offset voltage average is detected to exceed 12.5% of 1.65V in 1s, then it can be judged that current detection (or current sensor) circuit is faulted. System will shut down for protection.

Possible reason:

■Current detection (or current sensor) sampling circuit element is abnormal.

■Drive chip compressor current sampling AD terminal is badly welded or short-circuited.

Troubleshooting:

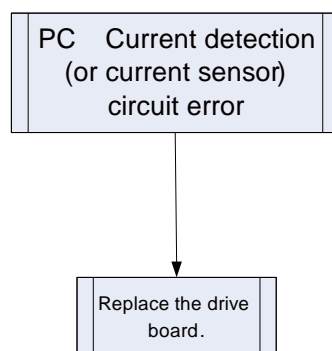

3.4.33 “Pd” Sensor Connection Protection

Error display: ODU mainboard, IDU wired controller and IDU receive light board will display Pd

Error judgment condition and method:

Sample the AD value of sensor through sensor detecting circuit and judge the range of AD value, If the sampling AD value exceeds upper limit and lower limit in 5 seconds continuously, report the error.

Possible reason:

- Poor contact between sensor and terminal in mainboard interface
- sensor is abnormal
- Detecting circuit is abnormal

Troubleshooting:

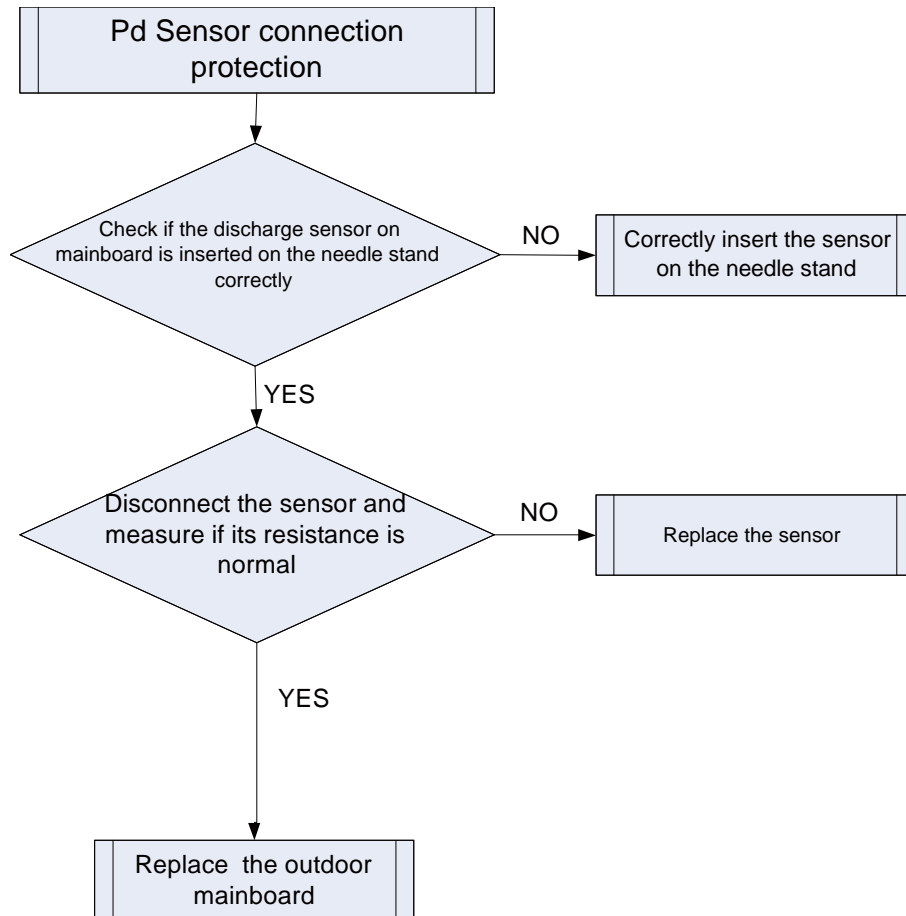

3.4.34 “PL” Bus Low-Voltage Protection

Error display: ODU mainboard, IDU wired control and IDU receiver light board will display PL

Error judgment condition and method:

When compressor is running and there is no other malfunction, if busbar voltage is lower than the set value for low voltage protection, then it can be judged that bus low-voltage protection occurs. System will shut down for protection.

Possible reason:

- Voltage of power grid is abnormal.
- Drive board busbar voltage sampling circuit element is damaged or drive board busbar voltage sampling AD terminal is abnormal.

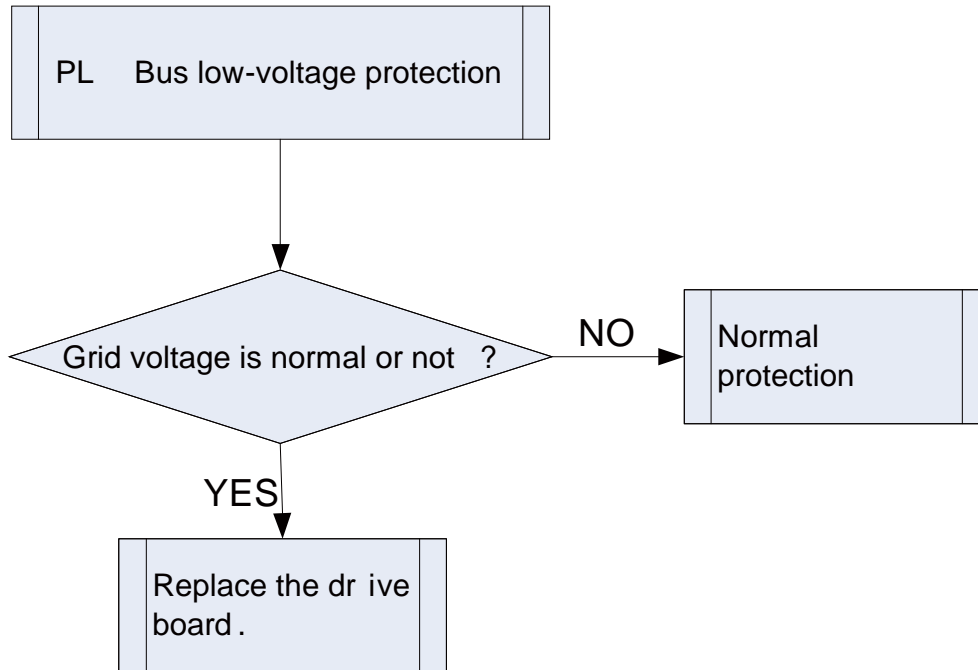
Troubleshooting:

3.4.35 "PH" Bus High-Voltage Protection

Error display: ODU mainboard, IDU wired control and IDU receiver light board will display **PH**

Error judgment condition and method:

If there is no other malfunction and the busbar voltage is higher than the set value for high voltage protection, then it can be judged that bus high-voltage protection occurs. System will shut down for protection.

Possible reason:

- Voltage of power grid is abnormal.
- Drive board busbar voltage sampling circuit element is damaged or drive board busbar voltage sampling AD terminal is abnormal.

Troubleshooting:

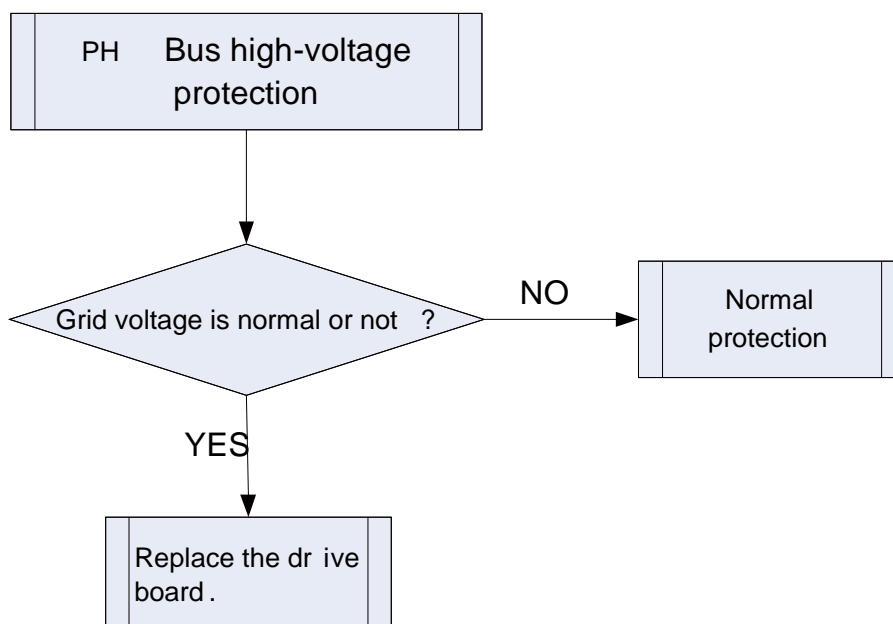

3.4.36 “PU” Charge Loop Error

Error display: ODU mainboard, IDU wired control and IDU receiver light board will display **PU**

Error judgment condition and method:

When the charge loop starts to get charged and the busbar voltage cannot reach the set value in a certain period of time, then it can be judged that charge loop error exists. System will shut down for protection.

Possible reason:

- Voltage of power grid is abnormal. Voltage is too low.
- Drive board charge loop element is abnormal.
- Drive board busbar voltage sampling circuit element is damaged or drive chip busbar voltage sampling AD terminal is abnormal.

Troubleshooting:

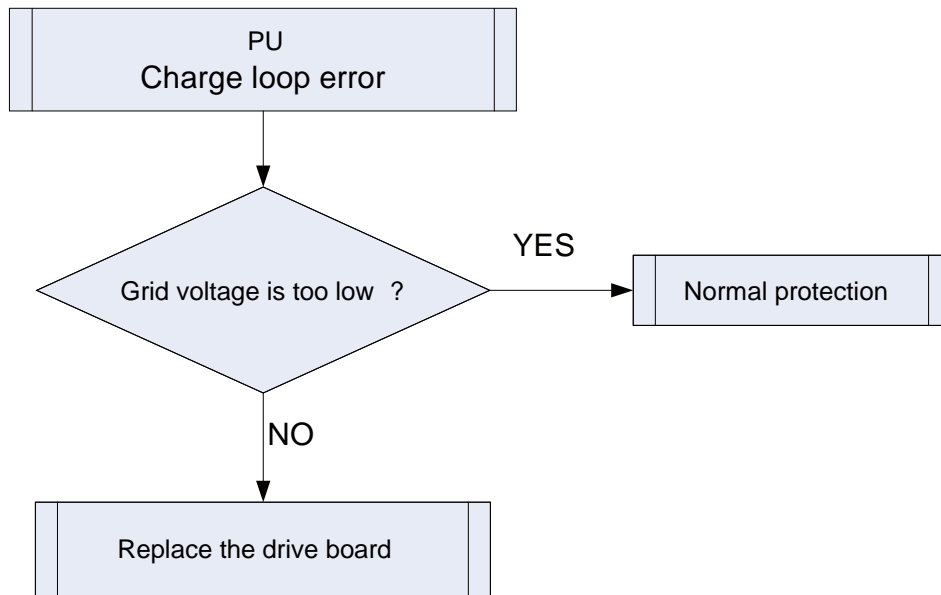

3.4.37 “ee” Drive Memory Chip Error

Error display: ODU mainboard, IDU wired control and IDU receiver light board will display **ee**

Error judgment condition and method:

If power is connected but the drive board with memory chip cannot detect the memory chip or read the memory chip data correctly, then it can be judged that drive memory chip error exists.

Possible reason:

- The drive board that needs memory chip is not installed with the memory chip.
- The lead or connector of memory chip is badly welded or short-circuited.

Troubleshooting

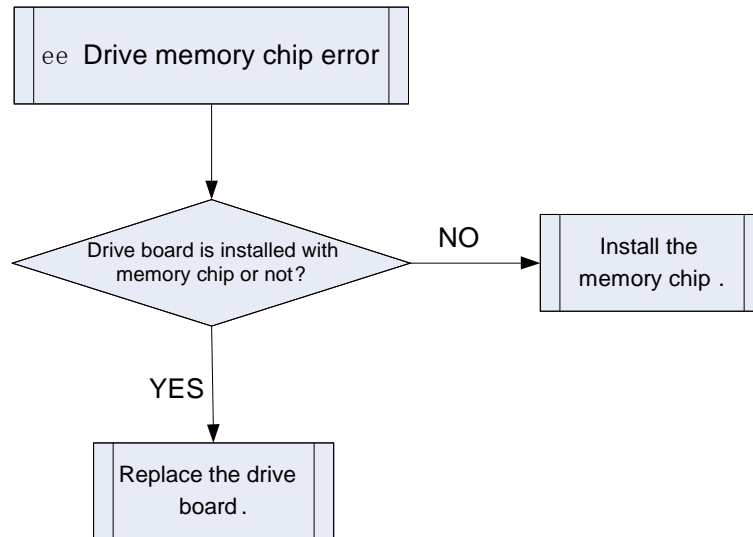

3.4.38 “c4” ODU Jumper Cap Error

Error display: ODU mainboard, IDU wired control and IDU receiver light board will display **c4**

Error judgment condition and method:

If jumper cap model doesn't match with mainboard, report the error

Possible reason:

- Jumper cap is not installed
- Jumper cap model is wrong
- Detecting circuit is abnormal

Troubleshooting:

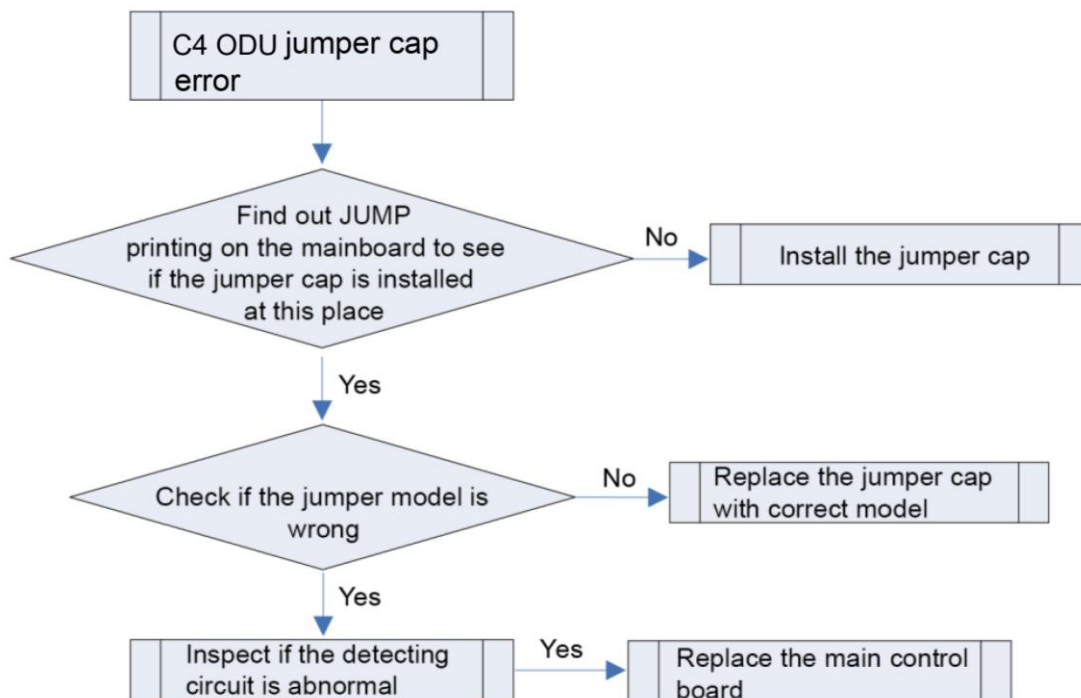

3.4.39 “EL” Emergency Stop (Fire Alarm)

If fire alarm terminal is enabled after the IDU mainboard connects to function expansion panel, error EL will be reported.

3.5 Failures Not Caused by Errors

(1) If your air conditioner fails to function normally, please first check the following items before maintenance:

Problem	Cause	Corrective measure
The air conditioner can't run.	If you turn off the unit and then immediately turn it on, in order to protect the compressor and avoid system overload, compressor will delay running for 3min.	Please wait for a while.
	Wire connection is wrong.	Connect wires according to the wiring diagram.
	Fuse or circuit breaker is broken.	Replace the fuse or switch on the circuit breaker.
	Power failure	Restart after power is resumed.
	Power plug is loose	Re-insert the power plug.
	Remote control has low battery.	Replace the batteries.
Bad cooling or heating effect.	Air inlet and outlet of indoor or outdoor units have been blocked.	Clear the obstacles and keep the room for indoor and outdoor units well ventilated.
	Improper temperature setting	Reset a proper temperature.
	Fan speed is too low.	Reset a proper fan speed.
	Air flow direction is not right.	Change the direction of air louvers.
	Doors or windows are open.	Close them.
	Exposed under direct sunshine	Put on curtains or louvers in front of the windows.
	Too many heat sources in the room.	Remove unnecessary heat sources.
	Filter is blocked or dirty.	Send for a professional to clean the filter.
	Air inlets or outlets of the units are blocked.	Clear away obstacles that are blocking the air inlets and outlets of indoor and outdoor units.

(2) The following situations are not operation failures.

	Time of occurrence	Cause
Mist comes from the air conditioner.	During operation	If the unit is running under high humidity, the wet air in the room will be quickly cooled down.
The air conditioner generates some noise.	System switches to heating mode after defrosting.	Defrosting process will generate some water, which will turn to water vapor.
	The air conditioner is buzzing at the beginning of operation.	Temperature control will be buzzing when it starts working. The noise will become weak 1min later.
Dust comes from the air conditioner.	When the unit is turned on, it purrs.	When the system is just started, the refrigerant is not stable. About 30s later, the purr of the unit becomes low.
	About 20s after the unit first enables the heating mode or there is refrigerant brushing sound when defrosting under heating.	It's the sound of 4-way valve switching direction. The sound will disappear after the valve changes its direction.
	There is hissing sound when the unit is started or stopped and a slight hissing sound during and after operation.	It's the sound of gaseous refrigerant that stops flowing and the sound of drainage system.
	There is a sound of crunching during and after operation.	Because of temperature change, front panel and other components may be swelled up and cause abrasion sound.
	There is a hissing sound when the unit is turned on or suddenly stopped during operation or after defrosting.	Because refrigerant suddenly stops flowing or changes the flow direction.
	The unit starts operation after being unused for a long time.	Dust inside the indoor unit comes out together with the air.
	The air conditioner generates some smell.	During operation



NOTICE:

Check the above items and adopt the corresponding corrective measures. If the air conditioner continues to function poorly, please stop the air conditioner immediately and contact Gree's authorized local service center. Ask our professional service staff to check and repair the unit.

4. Maintenance

4.1 System Diagram

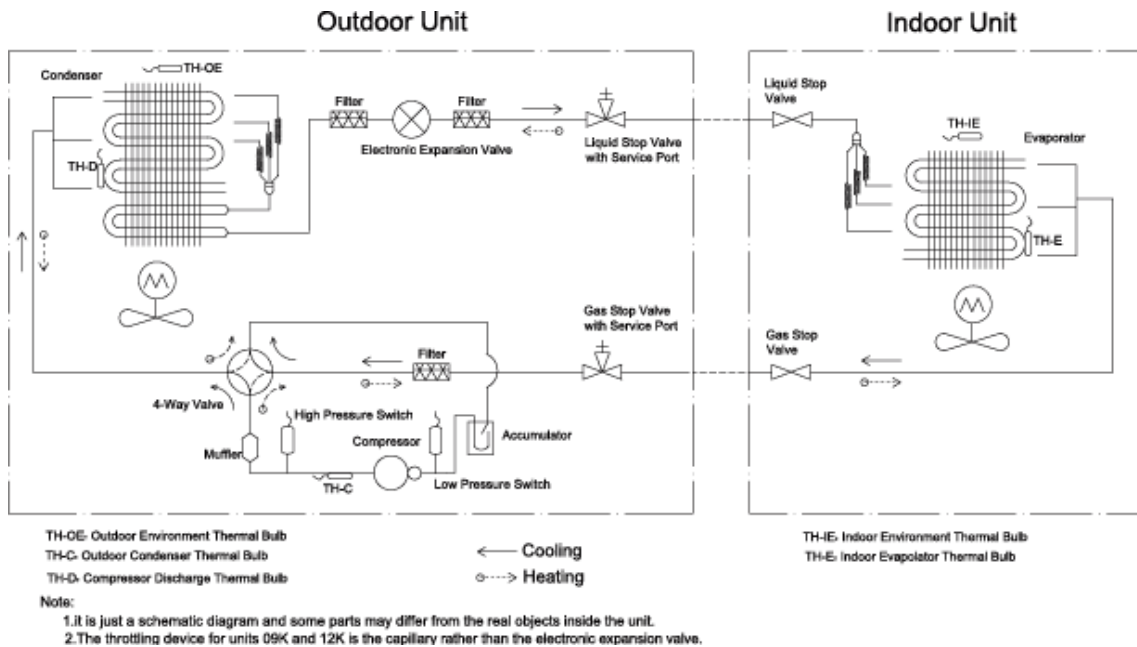

4.2 Connection Pipe Vacuum Pumping



Make sure the outlet of vacuum pump is away from fire source and is well-ventilated.

- (1) Remove the caps of the liquid valve, gas valve and also the service port.
- (2) Connect the hose at the low pressure side of the manifold valve assembly to the service port of the unit's gas valve, and meanwhile the gas and liquid valves should be kept closed in case of refrigerant leak.
- (3) Connect the hose used for evacuation to the vacuum pump.
- (4) Open the switch at the lower pressure side of the manifold valve assembly and start the vacuum pump. Meanwhile, the switch at the high pressure side of the manifold valve assembly should be kept closed, otherwise evacuation would fail.
- (5) The evacuation duration depends on the unit's capacity, generally.

Model	Time(min)
GUD35W/NhA-T	15
GUD50W/NhA-T	20
GUD71W/NhA-T, GUD85W/NhA-T, GUD100W/NhA-T, GUD100W/NhA-X	30
GUD125W/NhA-T, GUD140W/NhA-T, GUD125W/NhA-X, GUD140W/NhA-X, GUD160W/NhA-X	45

And verify if the pressure gauge at the low pressure side of the manifold valve assembly reads -1.0Mp (-75cmHg), if not, it indicates there is leak somewhere. Then, close the switch fully and then stop the vacuum pump.

(6) Wait for 10min to see if the system pressure can remain unchanged. During this time, the reading of the pressure gauge at the low pressure side can not be larger than 0.005Mp (0.38cmHg).

(7) Slightly open the liquid valve and let some refrigerant go to the connection pipe to balance the pressure inside and outside of the connection pipe, so that air will not come into the connection pipe when removing the hose. Notice that the gas and liquid valve can be opened fully only after the manifold valve assembly is removed.

(8) Place back the caps of the liquid valve, gas valve and also the service port.

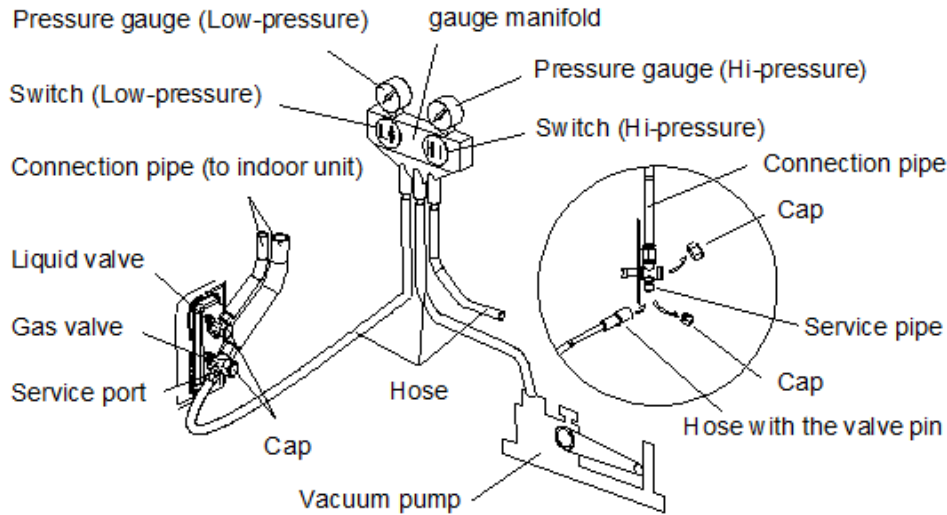

Notice:

For large-size units, there are maintenance ports for liquid valve and gas valve. During evacuation, you may connect the two hoses of the branch valve assembly to the maintenance ports to speed up the evacuation.

Refrigerant should be reclaimed into the appropriate storage tank. System should use oxygen-free nitrogen purging to ensure safety. This process may need to repeat several times. Do not use compressed air or oxygen in this process.

4.3 Refrigerant Charging

Pre-charging

Step 1: Connect the high pressure gauge line to the valve of liquid pipe and connect the low pressure gauge line to the valve of gas pipe. Connect the middle gauge line to the vacuum pump. Power on the vacuum pump and perform vacuum drying.

Step 2: After vacuum drying, close the high and low pressure gauge valves. Then remove the middle gauge line from the connector of vacuum pump. Then connect to the refrigerant tank.

Step 3: Loosen the middle gauge line from the connector of pressure gauge to a proper extent and slightly open the valve of refrigerant tank. Evacuate the middle gauge line. Then tighten up the connector again and completely open the valve of refrigerant tank at the same time.

Step 4: Keep the refrigerant tank erect and put it on an electronic scale. Record the current weight as m1.

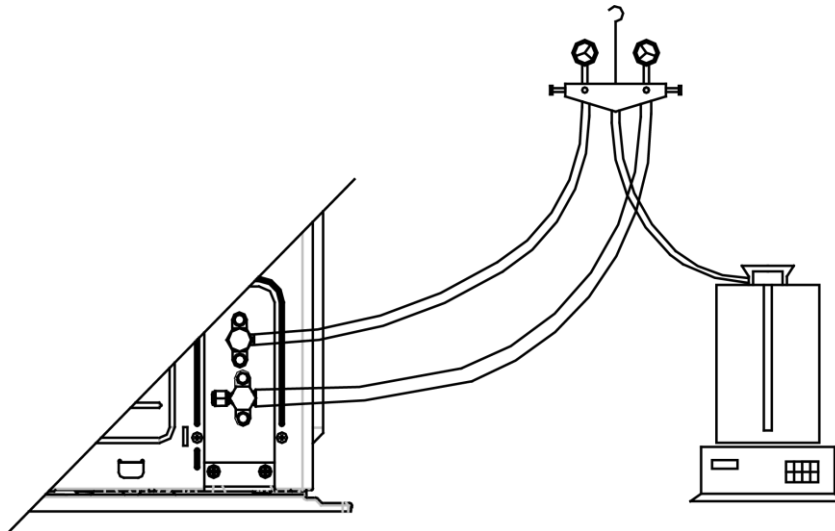

Step 5: Open the high pressure gauge valve (Keep the low pressure gauge valve closed). Then charge refrigerant into the system. Meanwhile, record the weight of refrigerant tank as m_2 .

Step 6: $m_1 - m_2 = m$. If m equals to the required charging quantity M , close the valve of refrigerant tank at once. Then move to step 8.

Step 7: If you can't continue to charge refrigerant into the system and the quantity of charged refrigerant is less than the required charging quantity, then record the current quantity of charged refrigerant:

$$m = m_1 - m_2$$

$$m' = M - m$$

The remaining charging quantity is: $m' = M - m$

Step 8: After charging, remove the pressure gauge.

Refrigerant charging when unit is turned on:

Step 1: Close the valve of refrigerant tank. First remove the pressure gauge lines and connect the outdoor unit to the indoor unit. Then reconnect the pressure gauge lines. Connect the low pressure gauge line to the other joint of gas valve and connect the high pressure gauge line to the liquid valve. Connect the middle gauge line to the vacuum pump. Power on the vacuum pump and perform vacuum drying.

Step 2: After vacuum drying, close the high and low pressure gauge valves. Then remove the middle gauge line from the connector of vacuum pump. Then connect to the refrigerant tank.

Step 3: Loosen the middle gauge line from the connector of pressure gauge to a proper extent and slightly open the valve of refrigerant tank. Evacuate the middle gauge line. Then tighten up the connector again and completely open the valve of refrigerant tank at the same time.

Step 4: Turn on the air conditioner and let it run for a while.

Step 5: Open the low pressure gauge valve (Keep the high pressure gauge valve closed). Then charge in the remaining charging quantity m' .

Step 6: After all required refrigerant is charged in, close the valve of refrigerant tank.

Step 7: Remove the pressure gauge to finish the refrigerant charging work.
Procedure of refrigerant charging

Following is the supplementary requirement for refrigerant charging on the basis of normal procedure:

- 1) Make sure that when charging refrigerant into the system, no other types of refrigerant will be mixed. The pipeline for refrigerant charging should be as short as possible to reduce the amount of refrigerant left in it.
- 2) The refrigerant tank should stand erect.
- 3) Make sure the refrigerating system is already grounded before refrigerant charging.
- 4) When charging is completed (or not yet completed), stick a label on the system.
- 5) Before re-charging refrigerant into the system, use oxygen-free nitrogen to perform pressure test. When charging is completed, perform leak test before trial running. Before leaving the workplace, perform a leak test again.

4.4 Maintenance of Major Components

4.5 Removal of Major Components

4.5.1 Removal of ODU Major Components

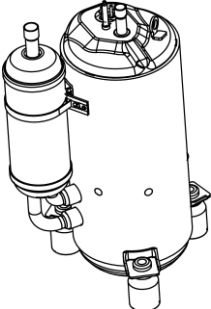
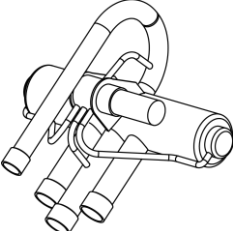
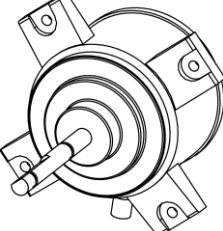
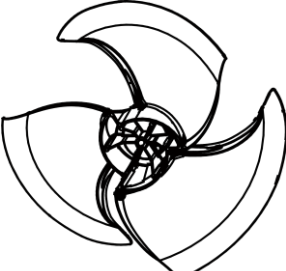
Picture	Name	Function
	Compressor	Through compression, the low pressure refrigerant occupies a less space. As its pressure and temperature both rise, it becomes high pressure and high temperature refrigerant. It is the power drive of the system.
	4-way valve	It is used to change directions, the flow of refrigerant in cooling/heating.
	Motor	The power drive of the fan. It enables the fan to run so as to provide smooth currents of air for forced convection and heat exchange of condenser and evaporator.
	Fan	It is used to provide smooth currents of air for forced convection and heat exchange of condenser and evaporator.

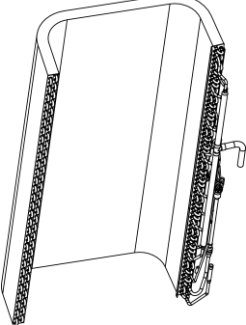
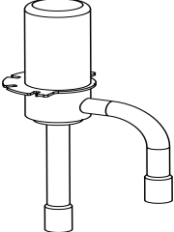
Picture	Name	Function
	<p>Gas liquid separator</p>	<p>Installed at the suction side of compressor, it can separate the liquefied refrigerant from the gaseous refrigerant to make sure that only gaseous refrigerant will be sucked into the compressor. If liquefied refrigerant gets inside the compressor, ineffective compressor or slugging phenomenon will occur.</p>
	<p>Condenser</p>	<p>It is used to transfer partial heat of the hot flow to the cold flow so that the flow temperature can reach the specified index. It is an energy exchanging device.</p>
	<p>Electronic expansion valve</p>	<p>It is used to lower the pressure and temperature of liquefied refrigerant and adjust the flow of refrigerant entering the evaporator.</p>

Model: GUD35W/NhA-T, GUD50W/NhA-T, GUD71W/NhA-T, GUD85W/NhA-T

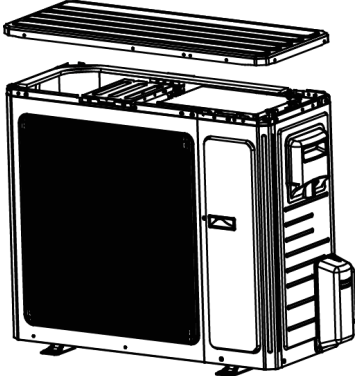
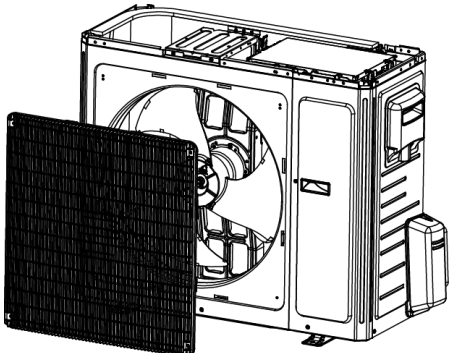
Removal of front panel		
Note: Before removing the front panel, make sure power is cut off.		
Step	Picture	Work instruction
<p>1.Remove the upper cover plate.</p>		<ul style="list-style-type: none"> ●Unscrew the screws of the upper cover plate with a screwdriver.
<p>2. Remove the front grill.</p>		<ul style="list-style-type: none"> ●Unscrew the screws of the front grill with a screwdriver.

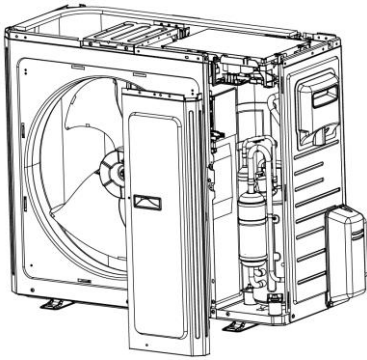
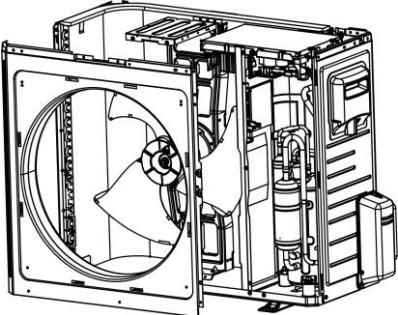
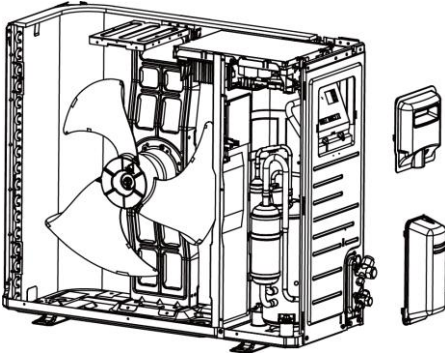
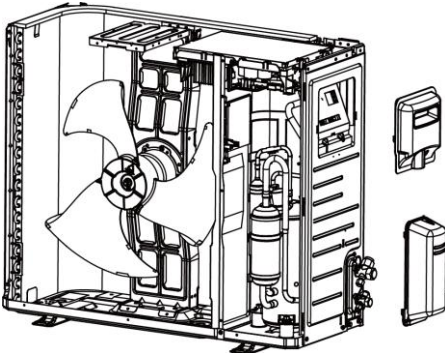
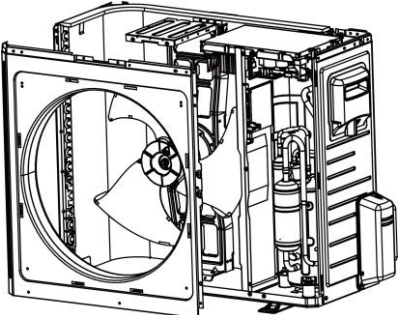
Removal of front panel		
Note: Before removing the front panel, make sure power is cut off.		
Step	Picture	Work instruction
3. Remove the front side plate.		<ul style="list-style-type: none"> ●Unscrew the screws of the front side plate with a screwdriver.
4. Remove the front panel.		<ul style="list-style-type: none"> ●Unscrew the screws that connect the front panel to the middle insulating board and screws around the front panel.
5. Remove the right side plate.		<ul style="list-style-type: none"> ●Unscrew the screws that connect the right side plate to the electric box and the screws around the right side plate.
6. Install the right side plate		<ul style="list-style-type: none"> ●Screw up the screws around the right side plate. Be careful to handle well the clasps at the bottom of the right side plate.
7. Install the front panel.		<ul style="list-style-type: none"> ●Install the front panel by mounting on 6 clasps on its both sides. Please note that there is one screw on the lower right side.

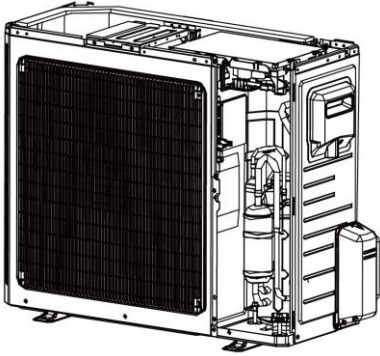
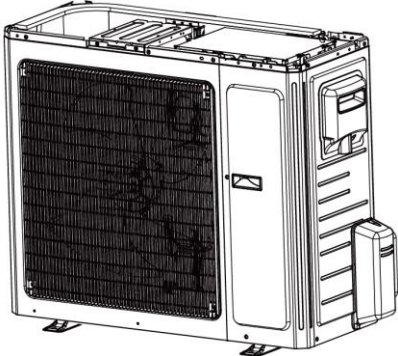
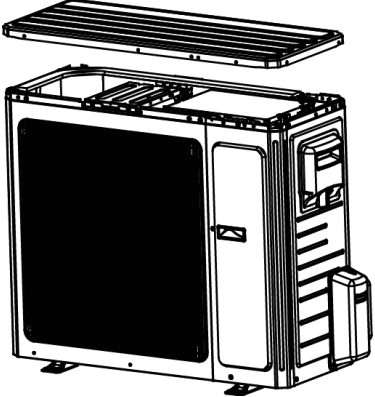
Removal of front panel		
Note: Before removing the front panel, make sure power is cut off.		
Step	Picture	Work instruction
8. Install the grill.		<ul style="list-style-type: none"> ● Attach the grill back in place and tighten up the screws.
9. Install the front side plate.		<ul style="list-style-type: none"> ● Tighten up the screws around the front side plate.
10. Install the upper cover plate.		<ul style="list-style-type: none"> ● Tighten up the screws around the upper cover plate.

Model: GUD35W/NhA-T, GUD50W/NhA-T, GUD71W/NhA-T, GUD85W/NhA-T

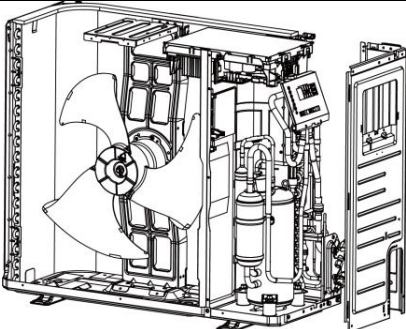
Removal of compressor		
Note: Before removing the compressor, make sure there is no refrigerant in the pipeline and power is cut off.		
Step	Picture	Work instruction
1.Remove wires.		<ul style="list-style-type: none"> ● Loosen the securing screws of the wires with a screwdriver. ● Remove the wires. <p>Note: When removing the wires, mark the wire terminals corresponding to their color so as to avoid misconnection.</p>

Removal of compressor

Note: Before removing the compressor, make sure there is no refrigerant in the pipeline and power is cut off.

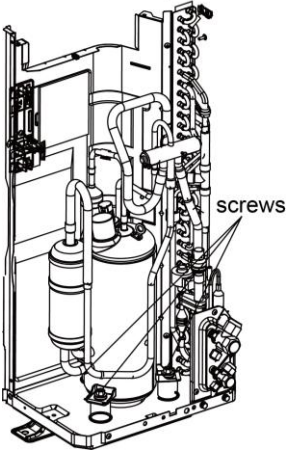
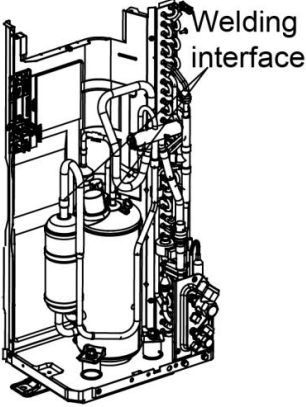
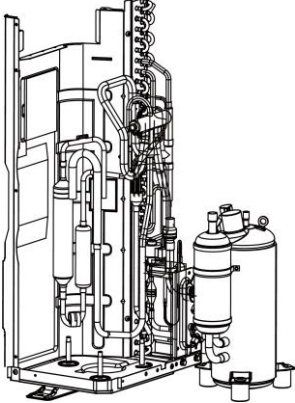
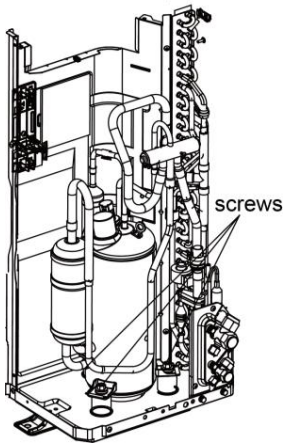
Step	Picture	Work instruction
<p>2. Loosen the securing screws at the foot of compressor.</p>		<ul style="list-style-type: none"> ● Use a wrench to twist off the screws at the foot of compressor.
<p>3. Break off the pipes that connecting to the compressor.</p>		<ul style="list-style-type: none"> ● Weld the pipes that are connected to the compressor. ● Then remove the pipes. <p>Note: When welding the pipes, do not let the flame burn the other components.</p>
<p>4. Remove the compressor from the chassis.</p>		<ul style="list-style-type: none"> ● Take out the compressor and replace it. <p>Note: When replacing the compressor, avoid touching the nearby pipeline and components.</p>
<p>5. Fix the new compressor back onto the chassis.</p>		<ul style="list-style-type: none"> ● After replacing the compressor, tighten up the screws at the foot of compressor.

Removal of compressor

Note: Before removing the compressor, make sure there is no refrigerant in the pipeline and power is cut off.

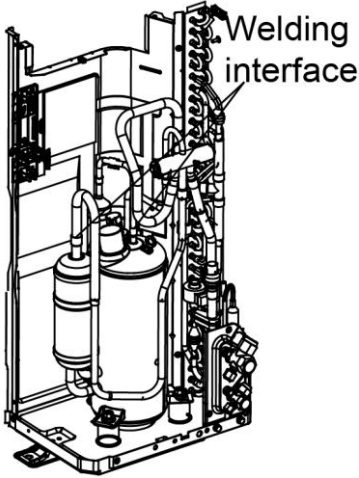
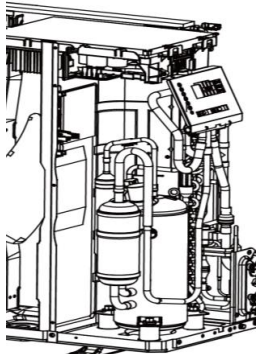
Step	Picture	Work instruction
<p>6. Connect the compressor suction port and exhaust port with the pipes.</p>		<ul style="list-style-type: none"> ●Weld the compressor connection pipes and connect them to the compressor. <p>Note: When replacing the compressor, avoid touching the nearby pipeline and components.</p>
<p>7. Connect the compressor wires.</p>		<ul style="list-style-type: none"> ●Connect the compressor wires to the wire terminals on the top of compressor. <p>Note: When connecting the wires, be sure to match the colors with the corresponding wire terminals.</p>

Model: GUD35W/NhA-T, GUD50W/NhA-T, GUD71W/NhA-T, GUD85W/NhA-T

Removal of 4-way valve

Note: Before removing the 4-way valve, make sure refrigerant is fully discharged from the unit and power is cut off.

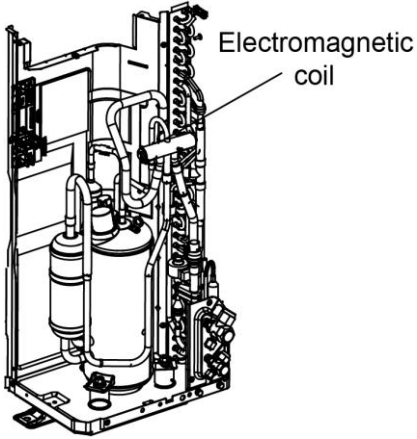
Step	Picture	Work instruction
<p>1. Take off the electromagnetic coil of the 4-way valve.</p>		<ul style="list-style-type: none"> ●Carefully unscrew the screws of electromagnetic coil with a screwdriver.

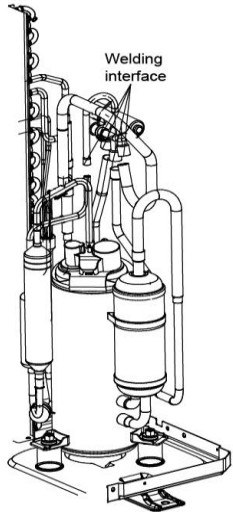
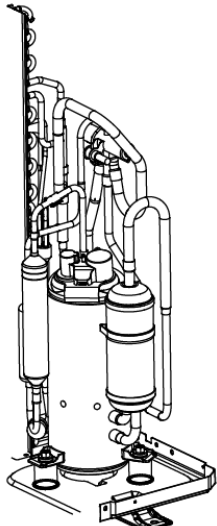
Removal of 4-way valve		
Note: Before removing the 4-way valve, make sure refrigerant is fully discharged from the unit and power is cut off.		
Step	Picture	Work instruction
2. Break off the connection pipes from the 4-way valve.		<ul style="list-style-type: none"> ●Use a soldering gun to loosen the 4 joints on the 4-way valve and then remove the connection pipes. <p>Note: When welding the pipes, the 4-way valve should be wrapped with wet cloth for cooling. Do not let the flame burn the other components.</p>
3. Replace the 4-way valve and connect it to the connection pipes.		<ul style="list-style-type: none"> ●Replace the 4-way valve and then use a soldering gun to weld the 4 joints of the 4-way valve. ●Tighten up the screws of electromagnetic coil with a screwdriver. <p>Note: When welding the pipes, the 4-way valve should be wrapped with wet cloth for cooling. Do not let the flame burn the other components.</p>

Model: GUD35W/NhA-T, GUD50W/NhA-T, GUD71W/NhA-T, GUD85W/NhA-T

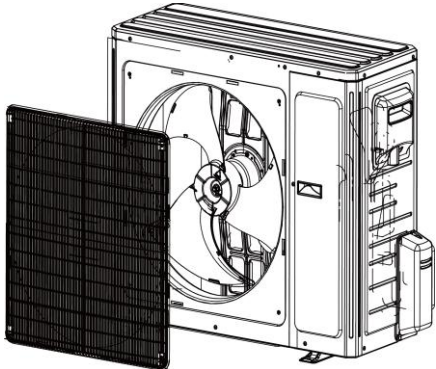
Removal of fan and motor		
Note: Before removing the fan, make sure power is cut off.		
Step	Picture	Work instruction
1. Remove the grill.		<ul style="list-style-type: none"> ●Use a screwdriver to unscrew the two screws on the upper left and lower right corners.

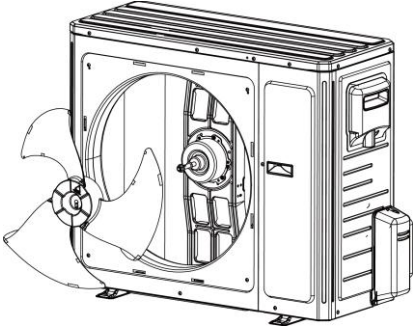
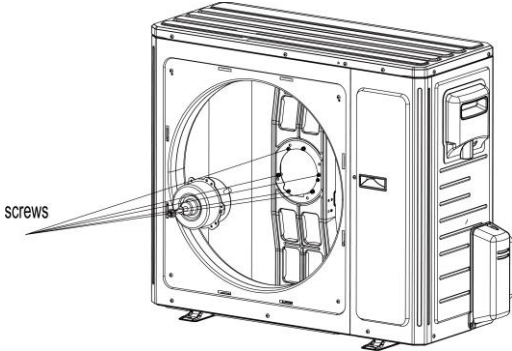
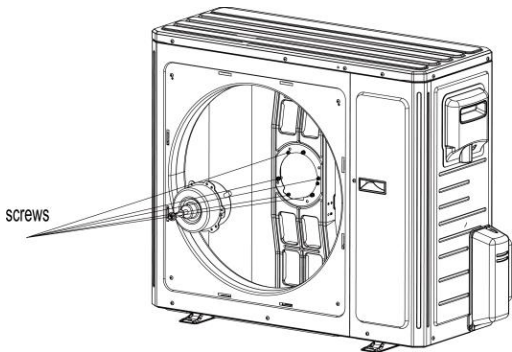
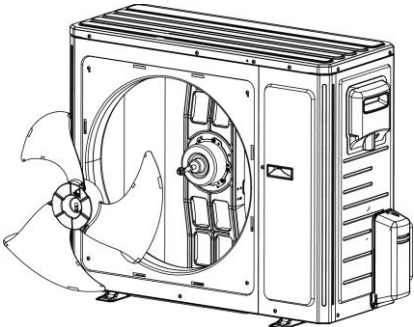
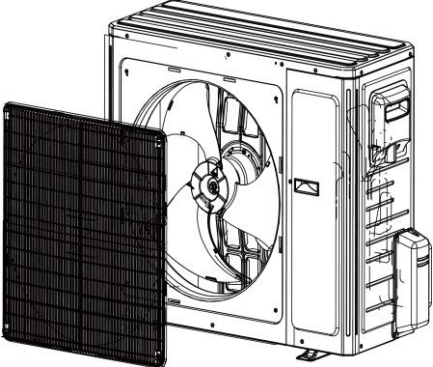
Removal of fan and motor		
Note: Before removing the fan, make sure power is cut off.		
Step	Picture	Work instruction
2. Remove the fan.		<ul style="list-style-type: none"> Use a wrench to remove the specialized nut and gasket of the fan. <p>Note: Please keep the nut and gasket safe after removing them from the fan.</p>
3. Remove motor.		<ul style="list-style-type: none"> Use a screwdriver to unscrew the bolt of motor. <p>Note: Motor wire should be first removed from the electric box.</p>
4. Install the motor.		<ul style="list-style-type: none"> Replace with a new motor. Then tighten up the screw bolt.
5. Install the fan.		<ul style="list-style-type: none"> Install the fan in place. Put on the gasket and use a wrench to secure the screw nut. <p>Note: After installing the fan, turn the fan by hand to see if it can run normally. If not, please check for the reason.</p>
6. Install the grill.		<ul style="list-style-type: none"> After replacing the motor, use a screwdriver to tighten up the screw bolt that secures the motor.

Model: GUD35W/NhA-T, GUD50W/NhA-T, GUD71W/NhA-T, GUD85W/NhA-T

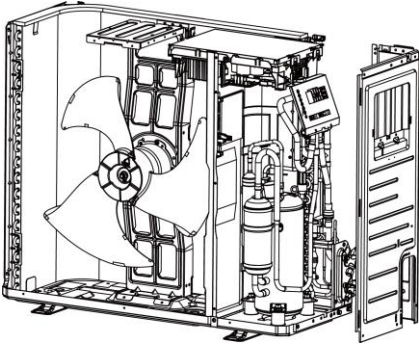
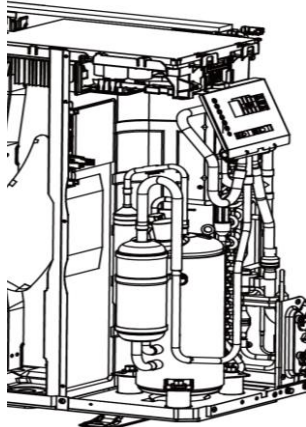
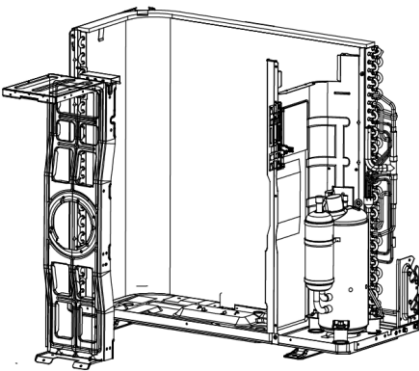
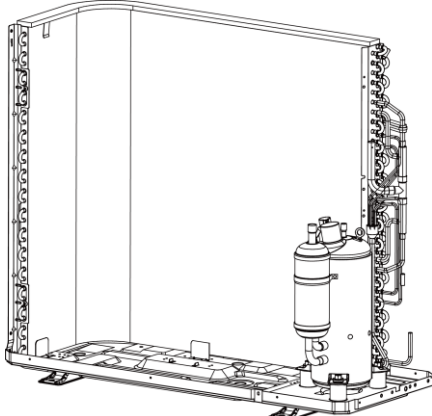
Removal of condenser		
Note: Before removing the condenser, make sure there is no refrigerant in the pipeline and power is cut off.		
Step	Picture	Work instruction
1. Remove the panels.		<ul style="list-style-type: none"> ●Remove the upper, lower and front panels.
2. Remove the electric box.		<ul style="list-style-type: none"> ●Loosen the wire clamp at the bottom of the electric box. ●Unscrew the screws of electric box. ●The connection wires inside and outside the electric box should be removed.
3. Remove motor support.		<ul style="list-style-type: none"> ●When removing the motor support, be careful to protect the components.
4. Remove the condenser.		<ul style="list-style-type: none"> ●Heat up the welding points of connection pipes through gas welding until the pipes break off. <p>Note: When welding the pipes, do not let the flame burn the other components. The welding points of condenser are steel and copper welding points. Be sure to maintain the welding quality.</p>

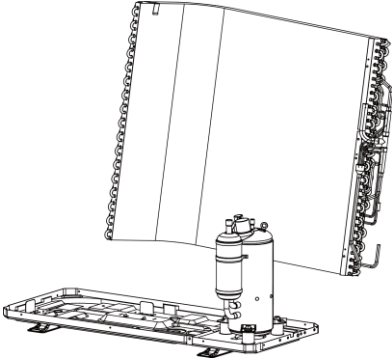
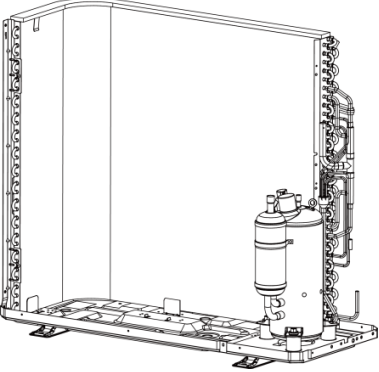
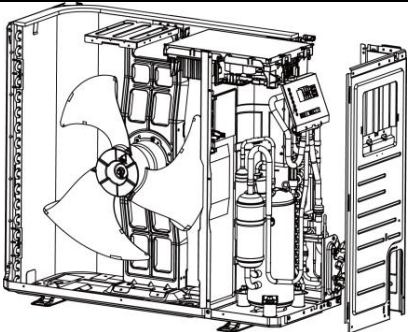
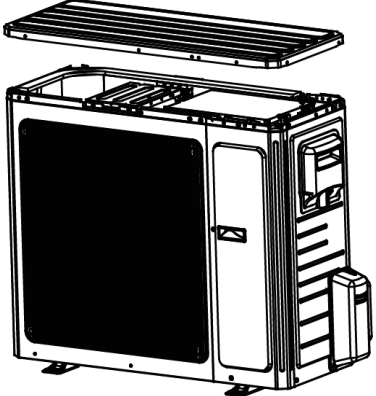
Removal of condenser		
Note: Before removing the condenser, make sure there is no refrigerant in the pipeline and power is cut off.		
Step	Picture	Work instruction
5. Take out the condenser.		<ul style="list-style-type: none"> Loosen the securing screws of condenser support. Take off the plate type heat exchanger and the support as a whole.
6. Install the new condenser.		<ul style="list-style-type: none"> Secure the screws of condenser and support. Then fix them together on the chassis. Install the condenser by referring to the positions of entering and leaving pipes. Weld the connection pipes. Nitrogen welding: the pressure of nitrogen is $0.5 \pm 0.1 \text{ kgf/cm}^2$ (relative pressure). Note: When welding the pipes, do not let the flame burn the other components.
7. Secure the electric box and arrange the wires according to the requirement.		<ul style="list-style-type: none"> Put the electric box in place and tighten up the screws of electric box. Arrange and secure the wires as original.
8. Check and open the upper and side panels.		<ul style="list-style-type: none"> Check whether each component and connection wire is well connected. If everything is OK, place back the upper, left and right side panels.

Model: GUD35W/NhA-T, GUD50W/NhA-T, GUD71W/NhA-T, GUD85W/NhA-T

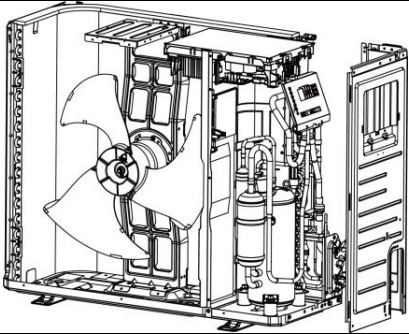
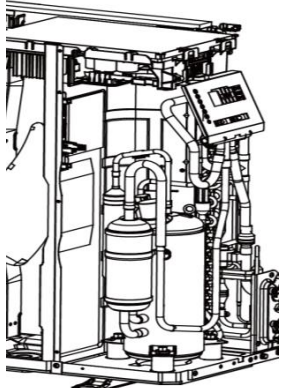
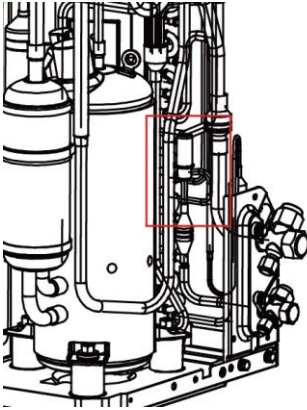
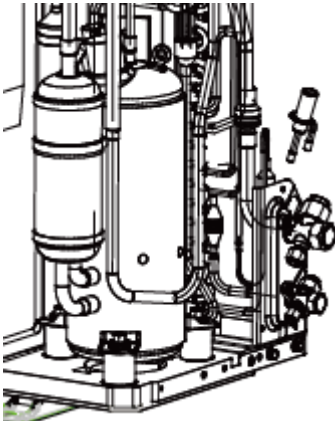
Removal of electronic expansion valve		
Note: Before removing the electronic expansion valve, make sure there is no refrigerant in the pipeline and power is cut off.		
Step	Picture	Work instruction
1. Loosen the wire clamp at the bottom of the electric box and the screws of electric box.		<ul style="list-style-type: none"> Remove the upper, lower and front panels. Loosen the wire clamp at the bottom of the electric box. Unscrew the screws of electric box.
2. Remove the electric box.		<ul style="list-style-type: none"> The connection wires inside and outside the electric box should be removed. When removing the electric box, be careful to protect the components.
3. Remove the electronic expansion valve.		<ul style="list-style-type: none"> Take off the coil of electronic expansion valve. Loosen the connection pipe of electronic expansion valve by welding. Then remove the connection pipe. <p>Note: When welding the pipe, do not let the flame bunt the other components.</p>
4. Take out the electronic expansion valve.		<ul style="list-style-type: none"> Take out the electronic expansion valve

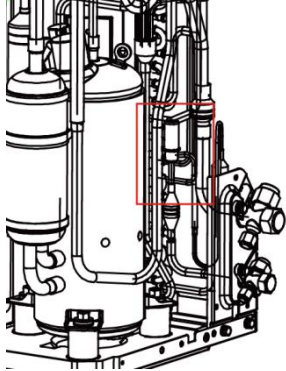
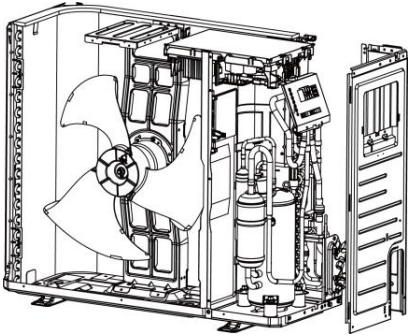
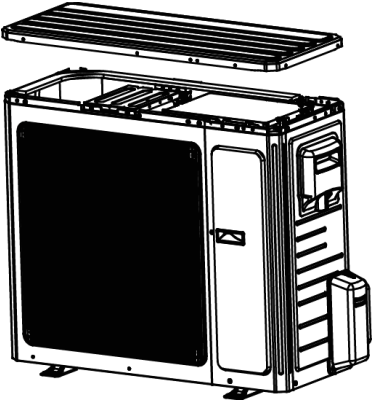
Removal of electronic expansion valve		
Note: Before removing the electronic expansion valve, make sure there is no refrigerant in the pipeline and power is cut off.		
Step	Picture	Work instruction
5. Install the new electronic expansion valve.		<ul style="list-style-type: none"> ●Weld the connection pipe of electronic expansion valve. ●When welding the electronic expansion valve, the valve should be wrapped with wet cloth. ●Nitrogen welding: the pressure of nitrogen is $0.5 \pm 0.1 \text{ kgf/ c m}^2$ (relative pressure). Note: When welding the pipes, do not let the flame burn the other components. ●Install the coil of electronic expansion valve.
6. Secure the electric box and arrange the wires as required.		<ul style="list-style-type: none"> ●Put the electric box back in place and tighten up the screws. ●Arrange the wires as original.
7. Check and install the panels.		<ul style="list-style-type: none"> ●Check whether each component and connection wire is well connected. ●If everything is OK, install the upper, left and right panels. Tighten up the screws.

Model: GUD100W/NhA-T, GUD125W/NhA-T, GUD140W/NhA-T,
 GUD100W/NhA-X, GUD125W/NhA-X, GUD140W/NhA-X

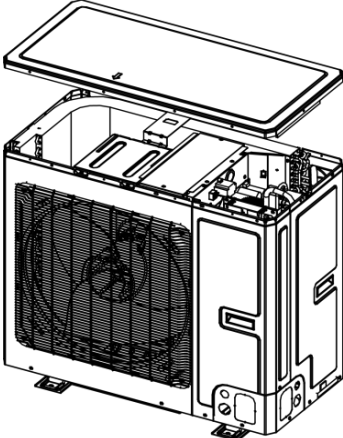
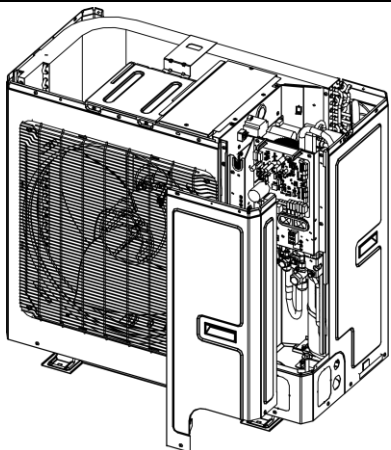
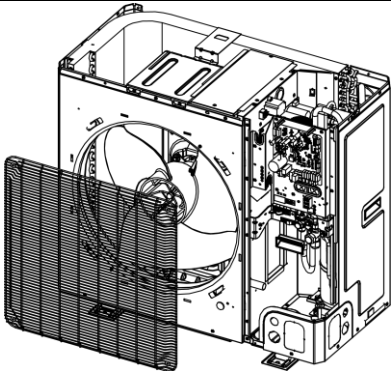
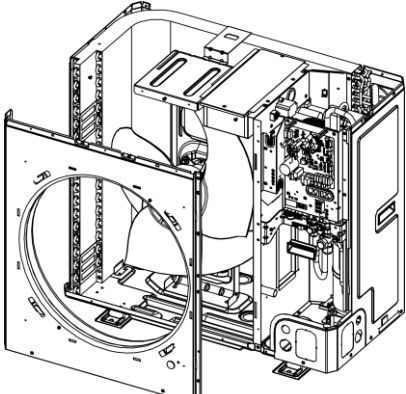
Removal of front panel		
Note: Before removing the front panel, make sure power is cut off.		
Step	Picture	Work instruction
1. Remove the upper cover plate.		<ul style="list-style-type: none"> ● Unscrew the screws of the upper cover plate with a screwdriver.
2. Remove the front side plate.		<ul style="list-style-type: none"> ● Unscrew the screws of the upper and front side plate with a screwdriver.
3. Remove the front grill.		<ul style="list-style-type: none"> ● Unscrew the screws of the front grill with a screwdriver.
4. Remove the front panel.		<ul style="list-style-type: none"> ● Unscrew the screws that connect the front panel to the middle insulating board and screws around the front panel.

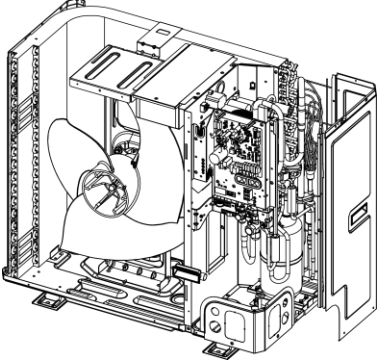
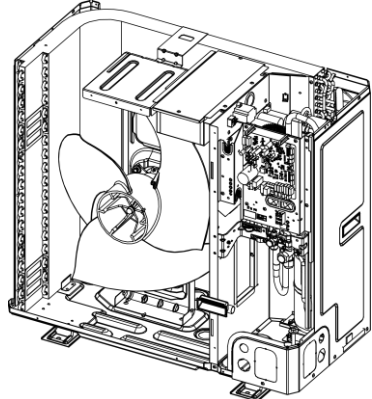
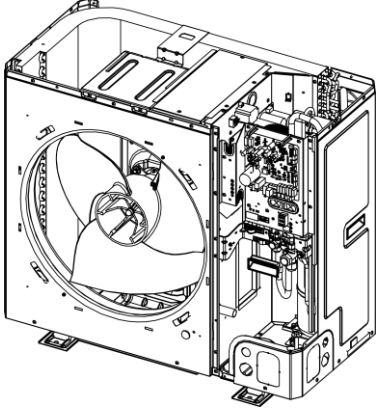
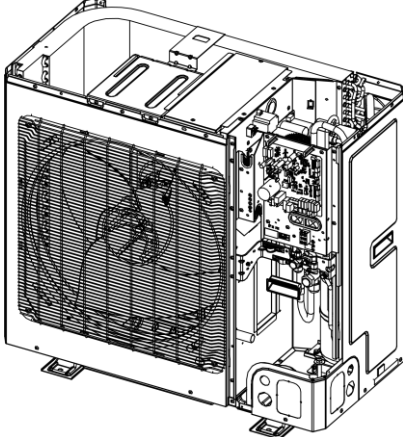
Removal of front panel		
Note: Before removing the front panel, make sure power is cut off.		
Step	Picture	Work instruction
5. Remove the right side plate.		<ul style="list-style-type: none"> ●Unscrew the screws that connect the right side plate to the electric box and the screws around the right side plate.
6. Install the right side plate		<ul style="list-style-type: none"> ●Screw up the screws around the right side plate. Be careful to handle well the clasps at the bottom of the right side plate.
7. Install the front panel.		<ul style="list-style-type: none"> ●Install the front panel by mounting on 6 clasps on its both sides. Please note that there is one screw on the lower right side.
8. Install the grill.		<ul style="list-style-type: none"> ●Attach the grill back in place and tighten up the screws.

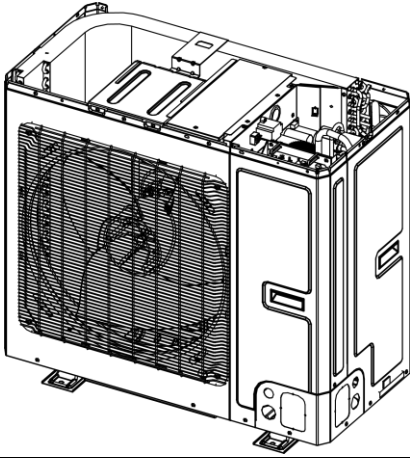
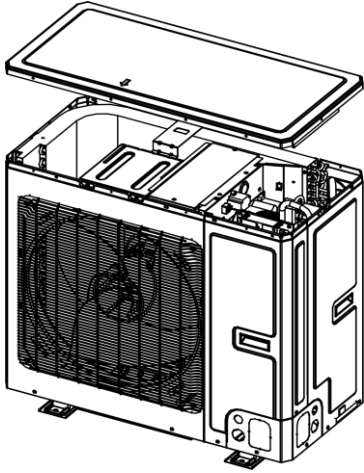
Removal of front panel		
Note: Before removing the front panel, make sure power is cut off.		
Step	Picture	Work instruction
9. Install the front side plate.		<ul style="list-style-type: none"> ●Fix the clasps on both sides of the plate and tighten up the screws.
10. Install the upper cover plate.		<ul style="list-style-type: none"> ●Tighten up the screws around the upper cover plate.

Model: GUD100W/NhA-T, GUD125W/NhA-T, GUD140W/NhA-T,
 GUD100W/NhA-X, GUD125W/NhA-X, GUD140W/NhA-X

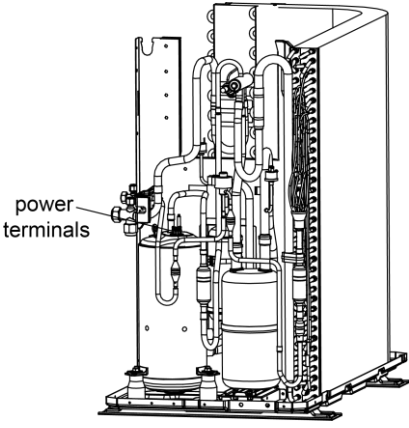
Removal of compressor/gas liquid separator		
Note: Before removing the compressor/gas liquid separator, make sure there is no refrigerant in the pipeline and power is cut off.		
Step	Picture	Work instruction
1. Remove wires.		<ul style="list-style-type: none"> ●Loosen the securing screws of the wires with a screwdriver. ●Remove the wires. <p>Note: When removing the wires, mark the wire terminals corresponding to their color so as to avoid misconnection.</p>

Removal of compressor/gas liquid separator

Note: Before removing the compressor/gas liquid separator, make sure there is no refrigerant in the pipeline and power is cut off.

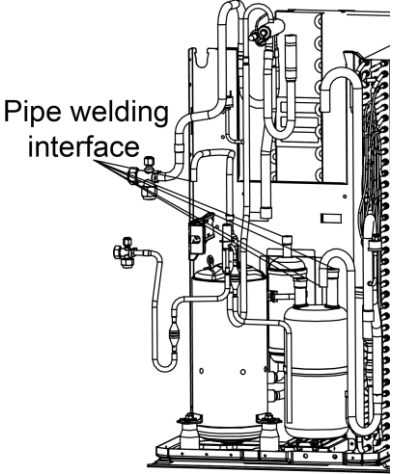
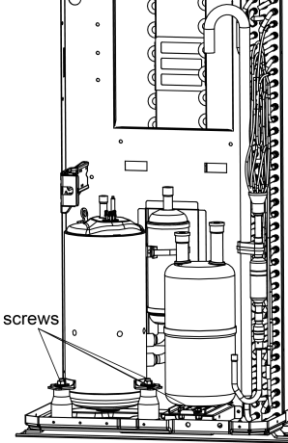
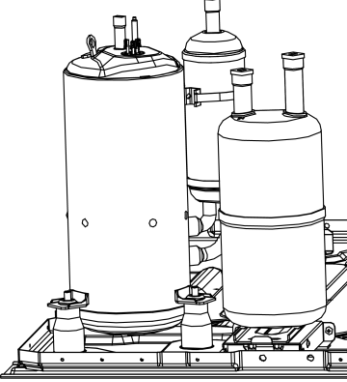
Step	Picture	Work instruction
<p>2 Break off the pipes that connecting to the compressor/gas liquid separator.</p>	 <p>Pipe welding interface</p>	<ul style="list-style-type: none"> ●Weld the pipes that are connected to the compressor/gas liquid separator. ●Then remove the pipes. <p>Note: When welding the pipes, do not let the flame burn the other components.</p>
<p>3. Loosen the compressor's base connectors / gas liquid separator's base nuts.</p>	 <p>screws</p>	<ul style="list-style-type: none"> ●Use a wrench to twist off the compressor/gas liquid separator's base nuts.
<p>4. Remove the compressor/gas liquid separator from the chassis.</p>		<ul style="list-style-type: none"> ●Take away the compressor/gas liquid separator and replace with a new one. <p>Note: When replacing the compressor/gas liquid separator, avoid touching the nearby pipeline and components.</p>

Removal of compressor/gas liquid separator

Note: Before removing the compressor/gas liquid separator, make sure there is no refrigerant in the pipeline and power is cut off.

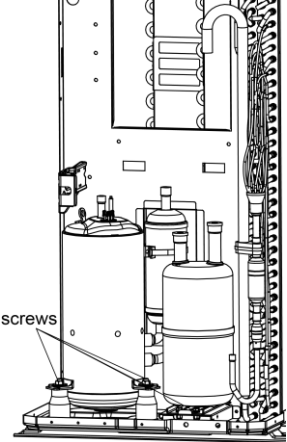
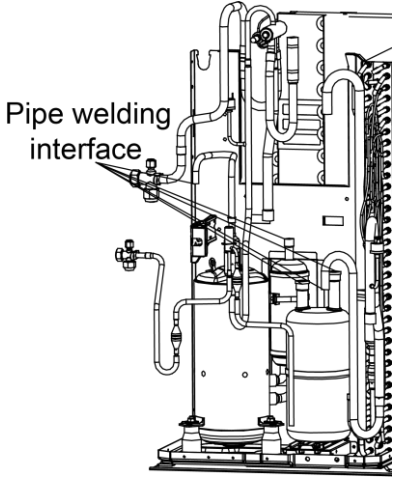
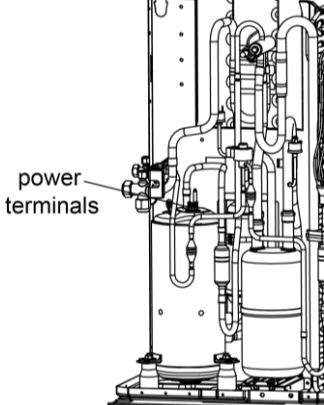
Step	Picture	Work instruction
<p>5. Install the new compressor/gas liquid separator onto the chassis.</p>		<ul style="list-style-type: none"> ●After replacing the compressor/gas liquid separator, tighten up the base screw nuts.
<p>6. Connect the welding interfaces of compressor/gas liquid separator to the pipeline.</p>		<ul style="list-style-type: none"> ●Weld the connection pipes of compressor so as to connect them to the compressor. <p>Note: When replacing the compressor, avoid touching the nearby pipeline and components.</p>
<p>7. Connect the compressor wires.</p>		<ul style="list-style-type: none"> ●Connect the compressor wires to the wire terminals on the top of compressor. <p>Note: When connecting the wires, be sure to match the colors with the corresponding wire terminals.</p>

Model: GUD100W/NhA-T, GUD125W/NhA-T, GUD140W/NhA-T,
 GUD100W/NhA-X, GUD125W/NhA-X, GUD140W/NhA-X

Removal of 4-way valve

Note: Before removing the 4-way valve, make sure refrigerant is fully discharged from the unit and power is cut off.

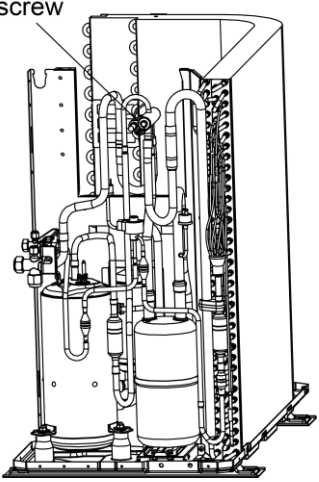
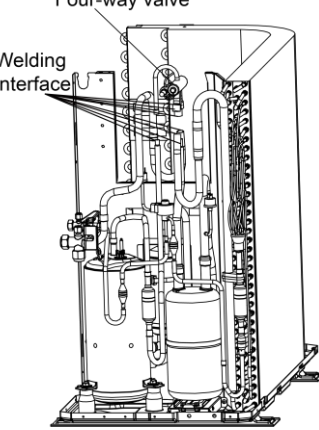
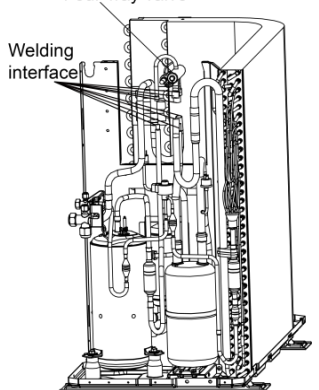
Step	Picture	Work instruction
<p>1. Take off the coil of the 4-way valve.</p>		<ul style="list-style-type: none"> ●Carefully unscrew the screws of electromagnetic coil with a screwdriver.
<p>2. Break off the connection pipes from the 4-way valve.</p>		<ul style="list-style-type: none"> ●Use a soldering gun to loosen the 4 joints on the 4-way valve and then remove the connection pipes. <p>Note: When welding the pipes, the 4-way valve should be wrapped with wet cloth for cooling. Do not let the flame burn the other components.</p>
<p>3. Replace the 4-way valve and connect it to the connection pipes.</p>		<ul style="list-style-type: none"> ●Replace the 4-way valve and then use a soldering gun to weld the 4 joints of the 4-way valve. <p>Note: When welding the pipes, the 4-way valve should be wrapped with wet cloth for cooling. Do not let the flame burn the other components.</p>

Removal of 4-way valve

Note: Before removing the 4-way valve, make sure refrigerant is fully discharged from the unit and power is cut off.

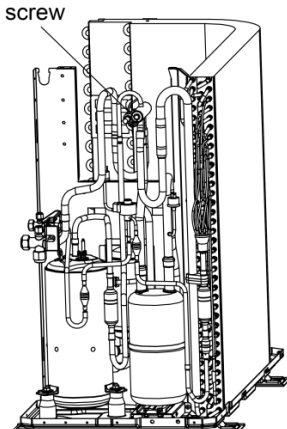
Step	Picture	Work instruction
4. Install the coil of 4-way valve.		<ul style="list-style-type: none"> ●Tighten the screws of the coil of 4-way valve with a screwdriver.

Model: GUD100W/NhA-T, GUD125W/NhA-T, GUD140W/NhA-T,
GUD100W/NhA-X, GUD125W/NhA-X, GUD140W/NhA-X

Removal of fan and motor

Note: Before removing the fan, make sure power is cut off.

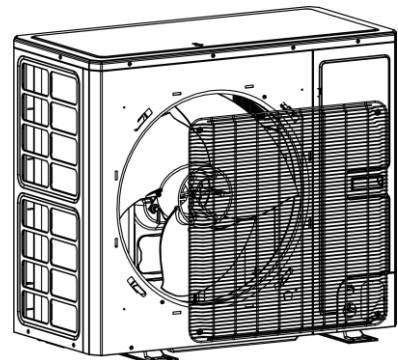
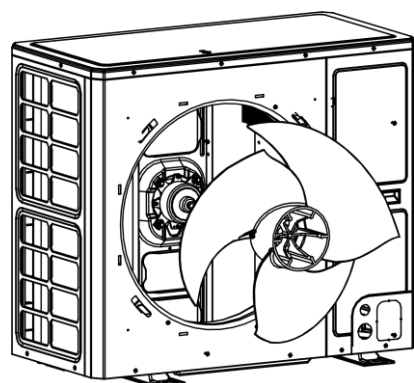
Step	Picture	Work instruction
1. Remove the grill.		<ul style="list-style-type: none"> ●Use a screwdriver to unscrew the two screws on the upper left and lower right corners.
2. Remove the fan.		<ul style="list-style-type: none"> ●Use a wrench to remove the specialized nut and gasket of the fan. <p>Note: Please keep the nut and gasket safe after removing them from the fan.</p>

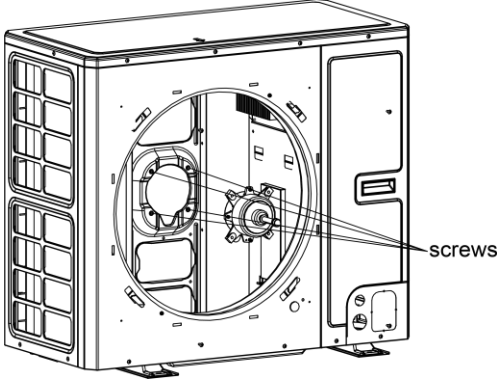
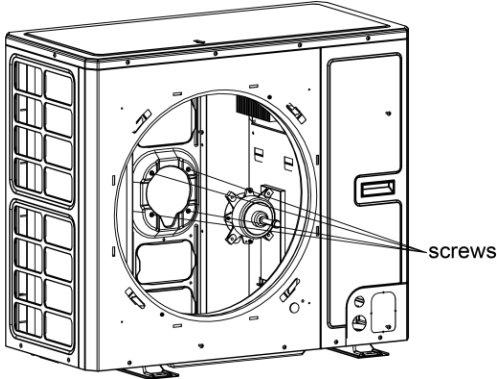
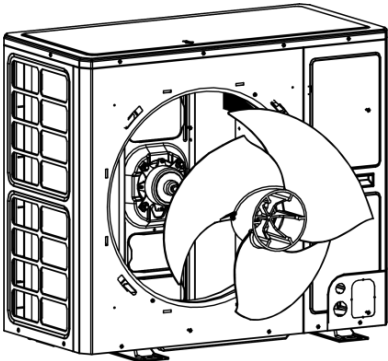
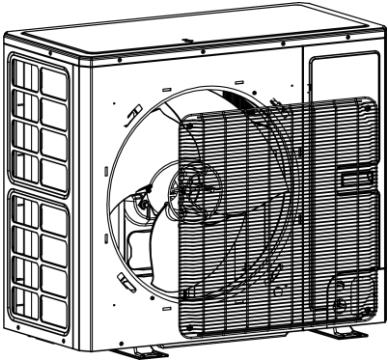
Removal of fan and motor		
Note: Before removing the fan, make sure power is cut off.		
Step	Picture	Work instruction
3. Remove motor.		<ul style="list-style-type: none"> ●Use a screwdriver to unscrew the bolt of motor. <p>Note: Motor wire should be first removed from the electric box.</p>
4. Install the motor.		<ul style="list-style-type: none"> ●Replace with a new motor. Then tighten up the screw bolt.
5. Install the fan.		<ul style="list-style-type: none"> ●Install the fan in place. Put on the gasket and use a wrench to secure the screw nut. <p>Note: After installing the fan, turn the fan by hand to see if it can run normally. If not, please check for the reason.</p>
6. Install the grill.		<ul style="list-style-type: none"> ●After replacing the motor, use a screwdriver to tighten up the screw bolt that secures the motor. Arrange the wires according to the wiring diagram.

Model: GUD100W/NhA-T, GUD125W/NhA-T, GUD140W/NhA-T,
 GUD100W/NhA-X, GUD125W/NhA-X, GUD140W/NhA-X

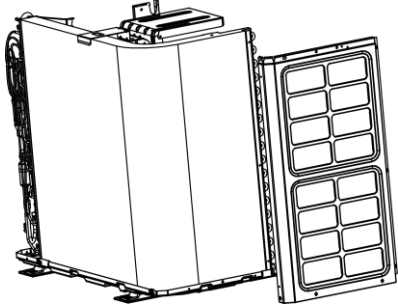
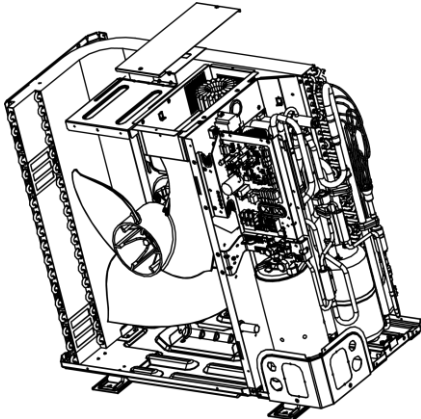
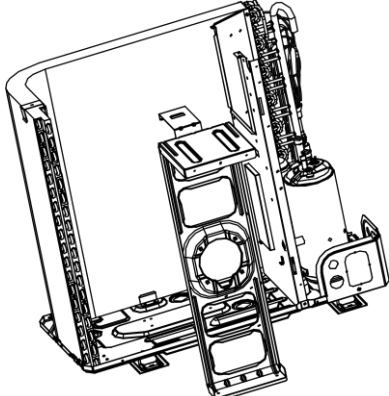
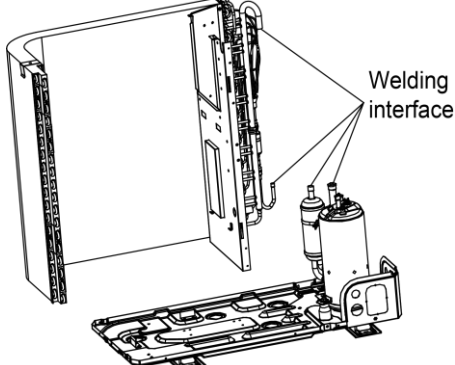
Removal of condenser		
Note: Before removing the condenser, make sure there is no refrigerant in the pipeline and power is cut off.		
Step	Picture	Work instruction
1. Remove the panels.		<ul style="list-style-type: none"> ●Remove the upper, lower and front panels.
2. Remove the electric box.		<ul style="list-style-type: none"> ●Loosen the wire clamp at the bottom of the electric box. ●Unscrew the screws of electric box. ●The connection wires inside and outside the electric box should be removed.
3. Remove motor support.		<ul style="list-style-type: none"> ●When removing the motor support, be careful to protect the components.
4. Remove the condenser.		<ul style="list-style-type: none"> ●Heat up the welding points of connection pipes through gas welding until the pipes break off. <p>Note: When welding the pipes, do not let the flame burn the other components. The welding points of condenser are steel and copper welding points. Be sure to maintain the welding quality.</p>

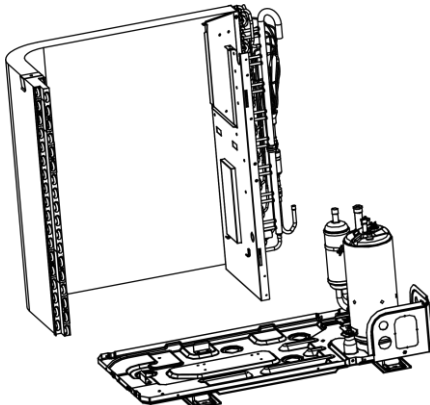
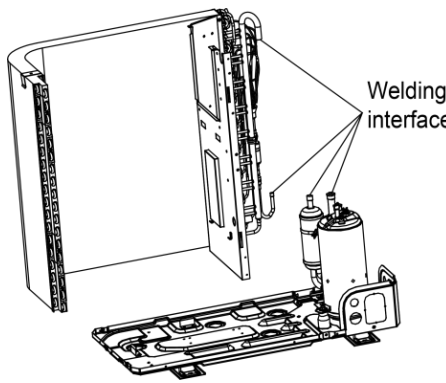
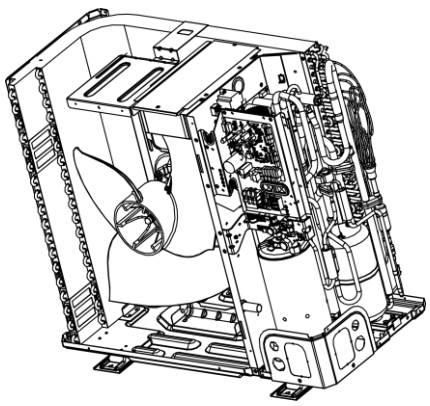
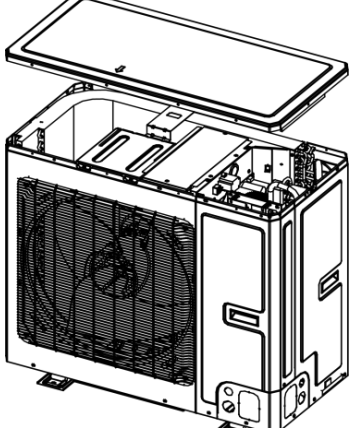
Removal of condenser		
Note: Before removing the condenser, make sure there is no refrigerant in the pipeline and power is cut off.		
Step	Picture	Work instruction
5. Take out the condenser.		<ul style="list-style-type: none"> Loosen the securing screws of condenser support. Take off the plate type heat exchanger and the support as a whole.
6. Install the new condenser.		<ul style="list-style-type: none"> Secure the screws of condenser and support. Then fix them together on the chassis. Install the condenser by referring to the positions of entering and leaving pipes. Weld the connection pipes. Nitrogen welding: the pressure of nitrogen is $0.5 \pm 0.1 \text{ kgf/cm}^2$ (relative pressure). Note: When welding the pipes, do not let the flame burn the other components.
7. Secure the electric box and arrange the wires according to the requirement.		<ul style="list-style-type: none"> Put the electric box in place and tighten up the screws of electric box. Arrange and secure the wires as original.
8. Check and open the upper and side panels.		<ul style="list-style-type: none"> Check whether each component and connection wire is well connected. If everything is OK, place back the upper, left and right side panels.

Model: GUD100W/NhA-T, GUD125W/NhA-T, GUD140W/NhA-T,
 GUD100W/NhA-X, GUD125W/NhA-X, GUD140W/NhA-X

Removal of electronic expansion valve

Note: Before removing the electronic expansion valve, make sure there is no refrigerant in the pipeline and power is cut off.

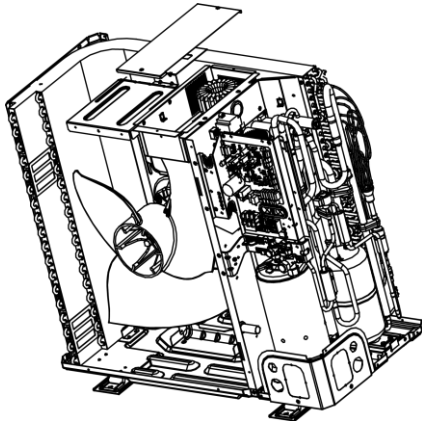
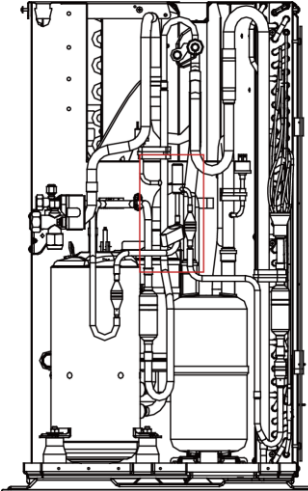
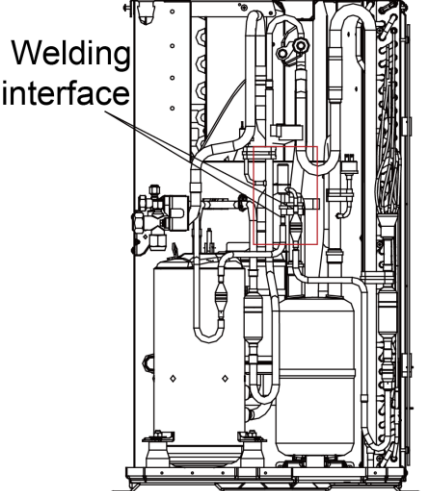
Step	Picture	Work instruction
<p>1. Remove the electric box.</p>		<ul style="list-style-type: none"> ●Remove the upper, lower and front panels. ●Loosen the wire clamp at the bottom of the electric box ●Unscrew the screws of electric box. ●The connection wires inside and outside the electric box should be removed. ●When removing the electric box, be careful to protect the components.
<p>2. Remove the fixed block.</p>		<ul style="list-style-type: none"> ●Remove the fixed block between the electronic expansion valve and the pipe.
<p>3. Remove the electronic expansion valve.</p>		<ul style="list-style-type: none"> ●Take off the coil of electronic expansion valve. ●Loosen the connection pipe of electronic expansion valve by welding. Then remove the connection pipe. <p>Note: When welding the pipe, do not let the flame bunt the other components.</p>

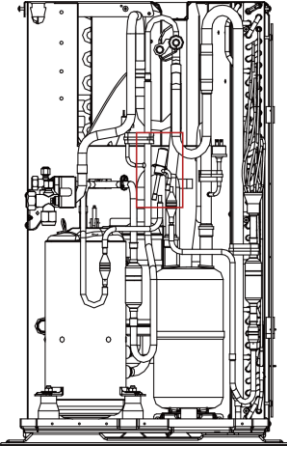
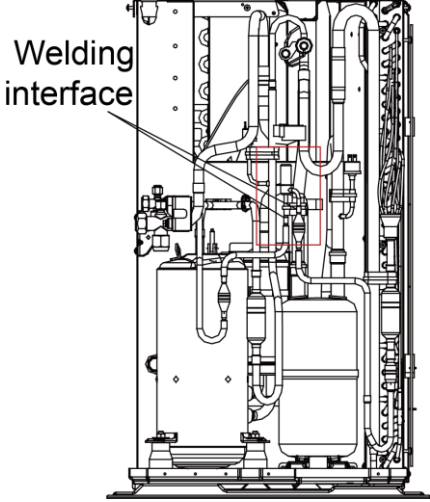
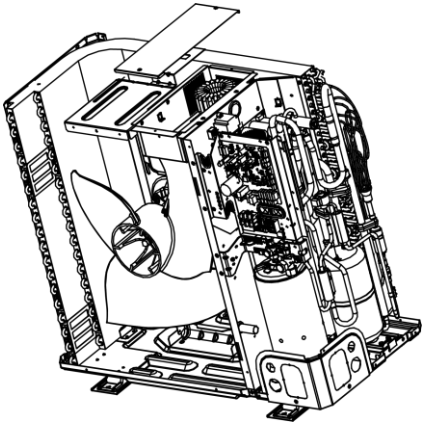
Removal of electronic expansion valve		
Note: Before removing the electronic expansion valve, make sure there is no refrigerant in the pipeline and power is cut off.		
Step	Picture	Work instruction
4. Take out the electronic expansion valve.		<ul style="list-style-type: none"> ● Take out the electronic expansion valve.
5. Install the new electronic expansion valve.		<ul style="list-style-type: none"> ● Weld the connection pipe of electronic expansion valve. ● When welding the electronic expansion valve, the valve should be wrapped with wet cloth. ● Nitrogen welding: the pressure of nitrogen is $0.5 \pm 0.1 \text{ kgf/cm}^2$ (relative pressure). Note: When welding the pipes, do not let the flame burn the other components. ● Install the coil of electronic expansion valve.
6. Secure the electric box and arrange the wires as required.		<ul style="list-style-type: none"> ● Put the electric box back in place and tighten up the screws. ● Arrange the wires as original.

Removal of electronic expansion valve

Note: Before removing the electronic expansion valve, make sure there is no refrigerant in the pipeline and power is cut off.

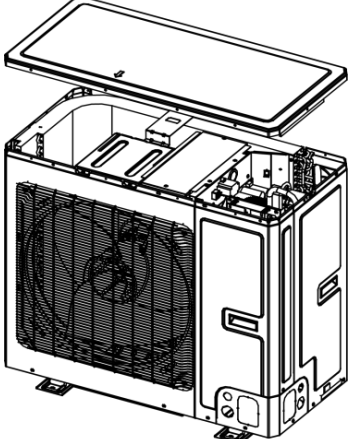
Step	Picture	Work instruction
<p>7. Check and open the upper and front panels.</p>		<ul style="list-style-type: none"> ●Check whether each component and connection wire is well connected. ●If everything is OK, install the upper, left and right panels. Tighten up the screws.

Model: GUD160W/NhA-X

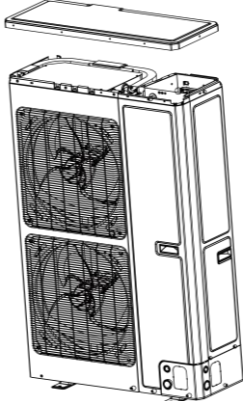
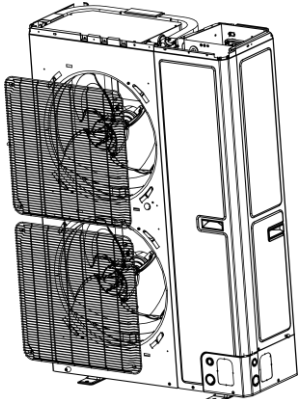

Removal of front panel

Note: Before removing the front panel, make sure power is cut off.

Step	Picture	Work instruction
<p>1. Remove the upper cover plate.</p>		<ul style="list-style-type: none"> ●Unscrew the screws of the upper cover plate with a screwdriver.
<p>2. Remove the front grill.</p>		<ul style="list-style-type: none"> ●Unscrew the screws of the front grill with a screwdriver.

Removal of front panel

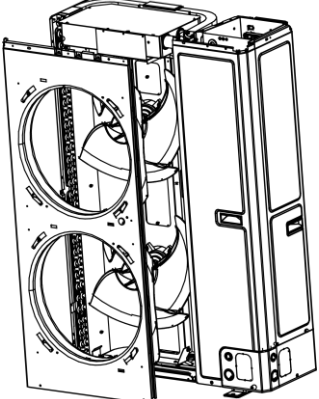
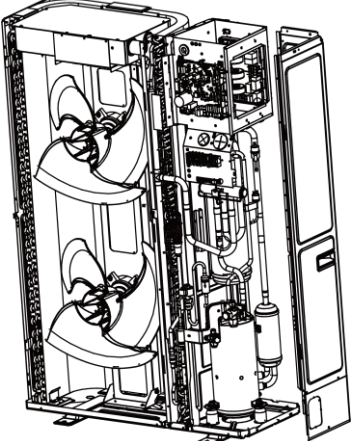
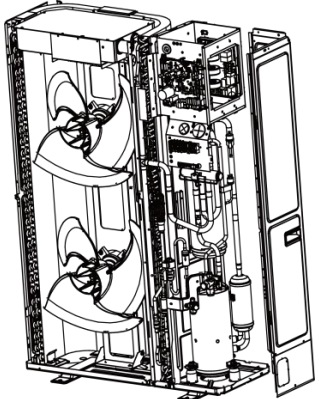
Note: Before removing the front panel, make sure power is cut off.

Step	Picture	Work instruction
3. Remove the front panel.		<ul style="list-style-type: none"> ● Unscrew the screws that connect the front panel to the middle insulating board and screws around the front panel.
4. Remove the right side plate.		<ul style="list-style-type: none"> ● Unscrew the screws that connect the right side plate to the electric box and the screws around the right side plate.
5. Install the right side plate		<ul style="list-style-type: none"> ● Screw up the screws around the right side plate. Be careful to handle well the clasps at the bottom of the right side plate.
6. Install the front panel.		<ul style="list-style-type: none"> ● Install the front panel by mounting on 6 clasps on its both sides. Please note that there is one screw on the lower right side.

Removal of front panel

Note: Before removing the front panel, make sure power is cut off.

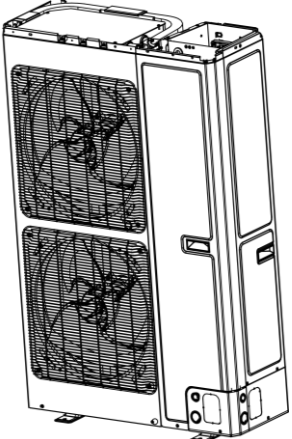
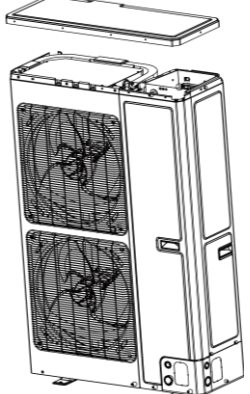
Step	Picture	Work instruction
7. Install the grill.		<ul style="list-style-type: none"> ● Attach the grill back in place and tighten up the screws.
8. Install the upper cover plate.		<ul style="list-style-type: none"> ● Tighten up the screws around the upper cover plate.

Model: GUD160W/NhA-X

Disassembly of compressor

Note: Before removing the compressor, make sure there is no refrigerant in the pipeline and power is cut off.

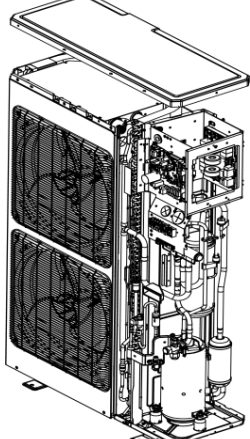
Step	Picture	Work instruction
1.Remove wires.		<ul style="list-style-type: none"> ● Loosen the securing screws of the wires with a screwdriver. ● Remove the wires. <p>Note: When removing the wires, mark the wire terminals corresponding to their color so as to avoid misconnection.</p>

Disassembly of compressor

Note: Before removing the compressor, make sure there is no refrigerant in the pipeline and power is cut off.

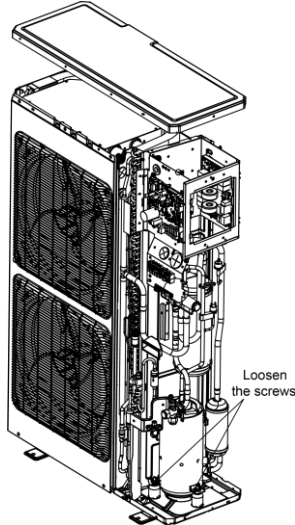
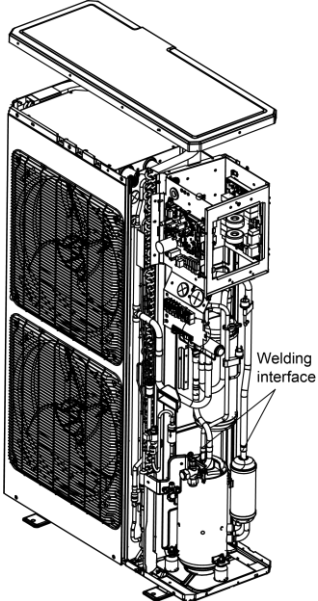
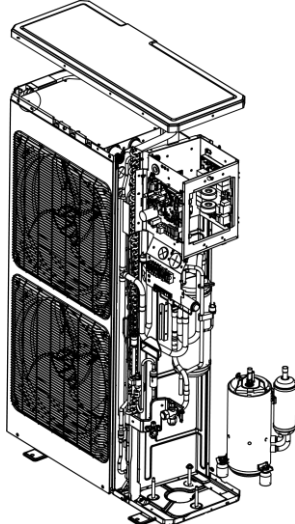
Step	Picture	Work instruction
<p>2. Loosen the securing screws at the foot of compressor.</p>		<ul style="list-style-type: none"> ●Use a wrench to twist off the screw nuts at the foot of compressor.
<p>3. Break off the pipes that connecting to the compressor.</p>		<ul style="list-style-type: none"> ●Weld the pipes that are connected to the compressor. ●Then remove the pipes. <p>Note: When welding the pipes, do not let the flame burn the other components.</p>
<p>4. Remove the compressor from the chassis.</p>		<ul style="list-style-type: none"> ●Take out the compressor and replace it. <p>Note: When replacing the compressor, avoid touching the nearby pipeline and components.</p>

Disassembly of compressor

Note: Before removing the compressor, make sure there is no refrigerant in the pipeline and power is cut off.

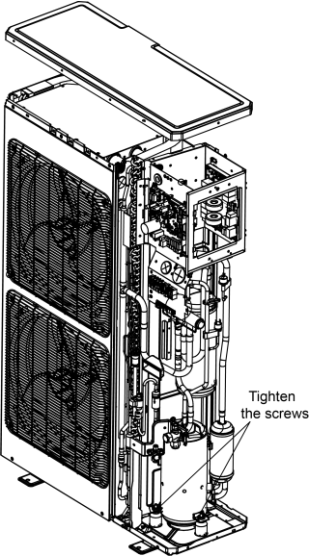
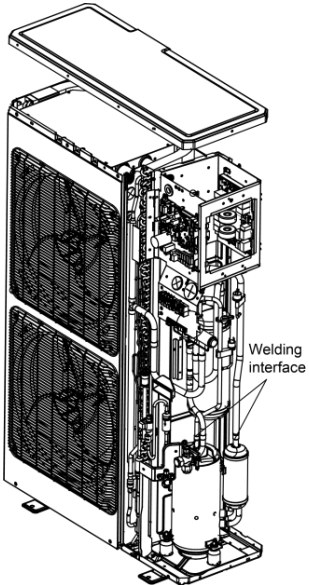
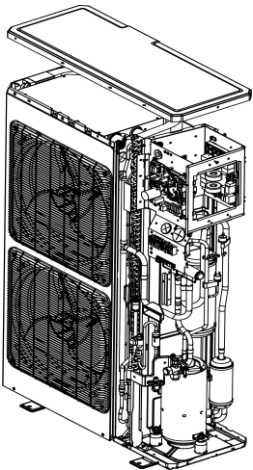
Step	Picture	Work instruction
<p>5. Fix the new compressor back onto the chassis.</p>		<ul style="list-style-type: none"> ● After replacing the compressor, tighten up the screws at the foot of compressor.
<p>6. Connect the compressor suction port and exhaust port with the pipes.</p>		<ul style="list-style-type: none"> ● Weld the compressor connection pipes and connect them to the compressor. <p>Note: When replacing the compressor, avoid touching the nearby pipeline and components.</p>
<p>8. Connect the compressor wires.</p>		<ul style="list-style-type: none"> ● Connect the compressor wires to the wire terminals on the top of compressor. <p>Note: When connecting the wires, be sure to match the colors with the corresponding wire terminals.</p>

Model: GUD160W/NhA-X

Removal of 4-way valve

Note: Before removing the 4-way valve, make sure refrigerant is fully discharged from the unit and power is cut off.

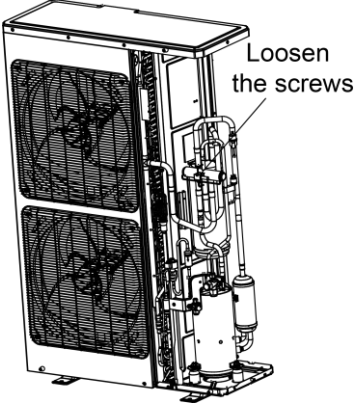
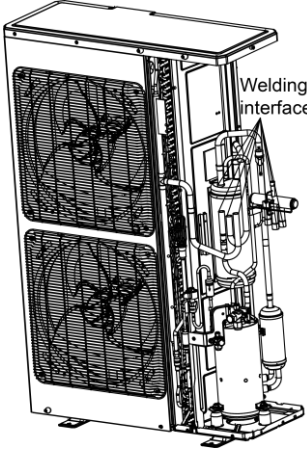
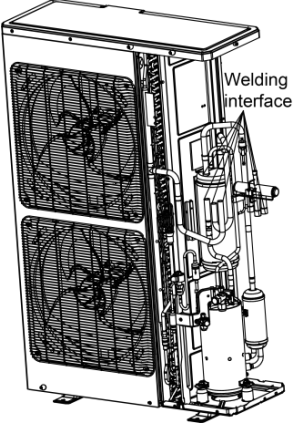
Step	Picture	Work instruction
<p>1. Take off the coil of the 4-way valve.</p>		<ul style="list-style-type: none"> ●Carefully unscrew the screws of electromagnetic coil with a screwdriver.
<p>2. Break off the connection pipes from the 4-way valve.</p>		<ul style="list-style-type: none"> ●Use a soldering gun to loosen the 4 joints on the 4-way valve and then remove the connection pipes. <p>Note: When welding the pipes, the 4-way valve should be wrapped with wet cloth for cooling. Do not let the flame burn the other components.</p>
<p>3. Replace the 4-way valve and connect it to the connection pipes.</p>		<ul style="list-style-type: none"> ●Replace the 4-way valve and then use a soldering gun to weld the 4 joints of the 4-way valve. <p>Note: When welding the pipes, the 4-way valve should be wrapped with wet cloth for cooling. Do not let the flame burn the other components.</p>

Removal of 4-way valve

Note: Before removing the 4-way valve, make sure refrigerant is fully discharged from the unit and power is cut off.

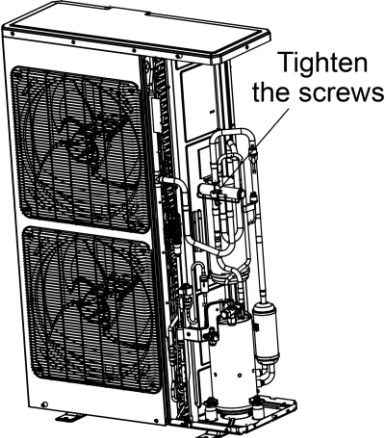
Step	Picture	Work instruction
4. Install the coil of 4-way valve.		<ul style="list-style-type: none"> ●Tighten the screws of the coil of 4-way valve with a screwdriver.

Model: GUD160W/NhA-X

Removal of fan and motor

Note: Before removing the fan, make sure power is cut off.

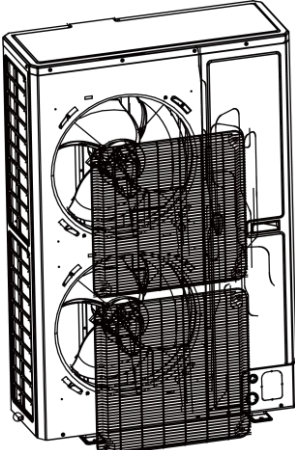
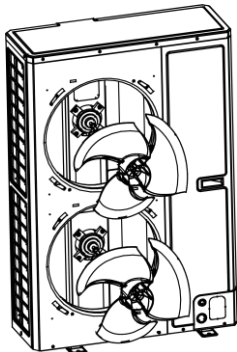
Step	Picture	Work instruction
1. Remove the grill.		<ul style="list-style-type: none"> ●Use a screwdriver to unscrew the two screws on the upper left and lower right corners.
2. Remove the fan.		<ul style="list-style-type: none"> ●Use a wrench to remove the specialized nut and gasket of the fan. <p>Note: Please keep the nut and gasket safe after removing them from the fan.</p>

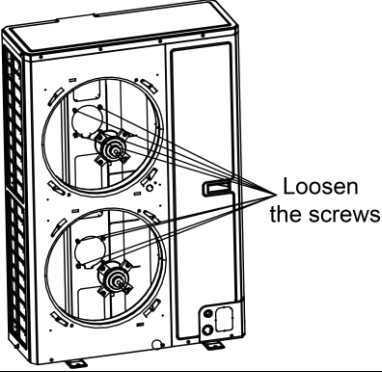
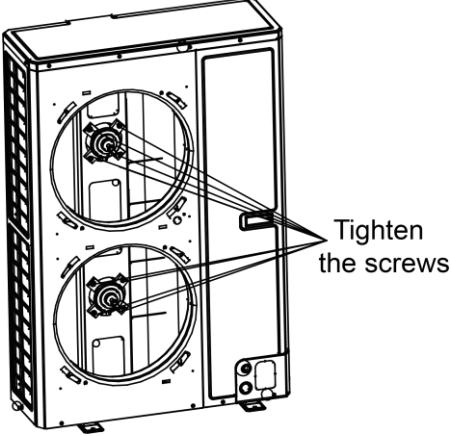
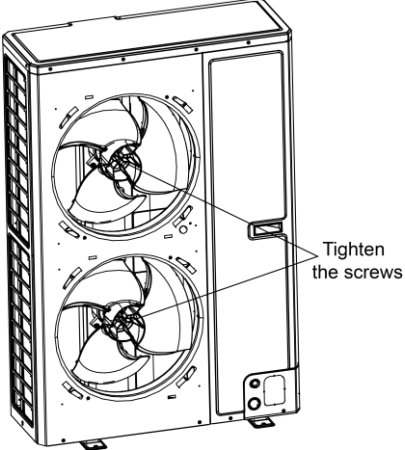
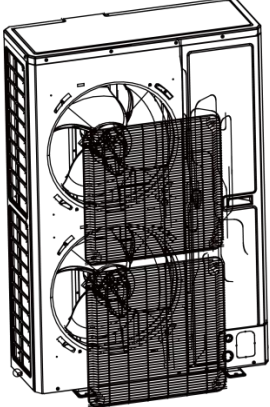
Removal of fan and motor		
Note: Before removing the fan, make sure power is cut off.		
Step	Picture	Work instruction
3. Remove motor.		<ul style="list-style-type: none"> ●Use a screwdriver to unscrew the bolt of motor. <p>Note: Motor wire should be first removed from the electric box.</p>
4. Install the motor.		<ul style="list-style-type: none"> ●Replace with a new motor. Then tighten up the screw bolt.
5. Install the fan.		<ul style="list-style-type: none"> ●Install the fan in place. Put on the gasket and use a wrench to secure the screw nut. <p>Note: After installing the fan, turn the fan by hand to see if it can run normally. If not, please check for the reason.</p>
6. Install the grill.		<ul style="list-style-type: none"> ●After replacing the motor, use a screwdriver to tighten up the screw bolt that secures the motor.

Model: GUD160W/NhA-X

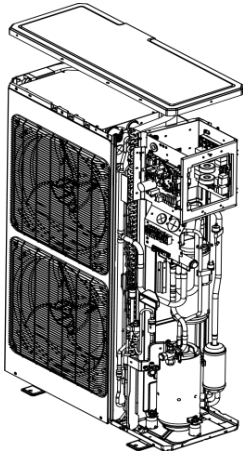
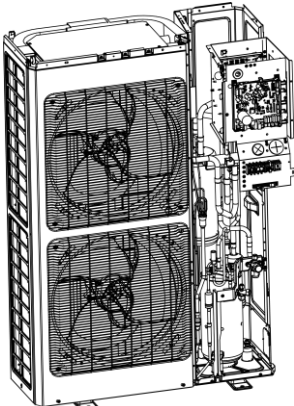
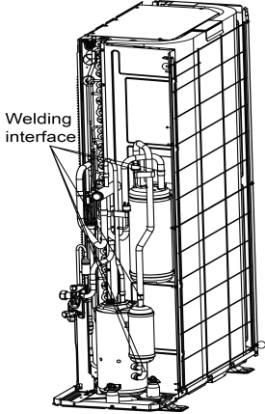
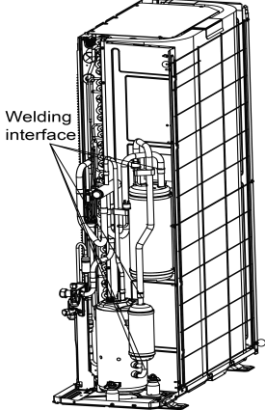
Removal of gas liquid separator		
Note: Before removing the gas liquid separator, make sure there is no refrigerant in the pipeline and power is cut off.		
Step	Picture	Work instruction
1. Loosen the wire clamp at the bottom of the electric box and the screws of electric box.		<ul style="list-style-type: none"> Remove the upper, lower and front panels. Loosen the wire clamp at the bottom of the electric box. Unscrew the screws of electric box.
2. Remove the electric box.		<ul style="list-style-type: none"> The connection wires inside and outside the electric box should be removed. When removing the electric box, be careful to protect the components.
3. Remove the compressor/gas liquid separator from the chassis.		<ul style="list-style-type: none"> Take away the compressor/gas liquid separator and replace with a new one. <p>Note: When replacing the compressor/gas liquid separator, avoid touching the nearby pipeline and components.</p>
4. Install the new gas liquid separator		<ul style="list-style-type: none"> Install the gas liquid separator by referring to the positions of entering and leaving pipes. Weld the 2 welding interfaces. Nitrogen welding: the pressure of nitrogen is $0.5 \pm 0.1 \text{ kgf/ c m}^2$ (relative pressure). Note: When welding the pipes, do not let the flame burn the other components. Tighten the screws of gas liquid separator.

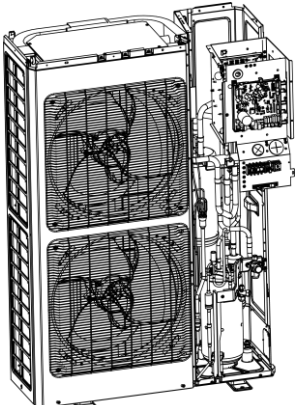
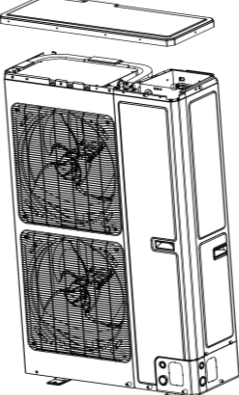
Removal of gas liquid separator		
Note: Before removing the gas liquid separator, make sure there is no refrigerant in the pipeline and power is cut off.		
Step	Picture	Work instruction
5. Secure the electric box and arrange the wires as required.		<ul style="list-style-type: none"> ●Put the electric box back in place and tighten up the screws. ●Arrange the wires as original.
6. Check and open the upper and side panels.		<ul style="list-style-type: none"> ●Check whether each component and connection wire is well connected. ●If everything is OK, install the upper, left and right panels. Tighten up the screws.

Model: GUD160W/NhA-X

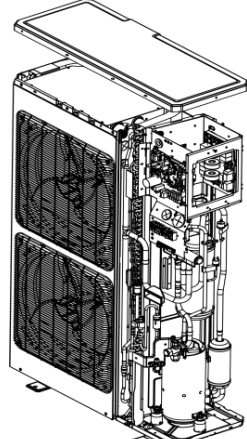
Removal of electronic expansion valve		
Note: Before removing the electronic expansion valve, make sure there is no refrigerant in the pipeline and power is cut off.		
Step	Picture	Work instruction
1. Loosen the wire clamp at the bottom of the electric box and the screws of electric box.		<ul style="list-style-type: none"> ●Remove the upper, lower and front panels. ●Loosen the wire clamp at the bottom of the electric box. ●Unscrew the screws of electric box.

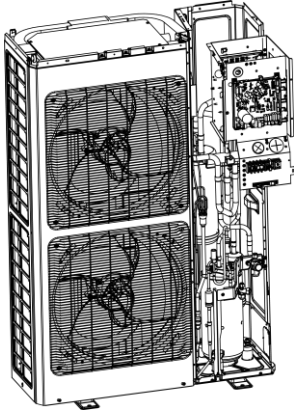
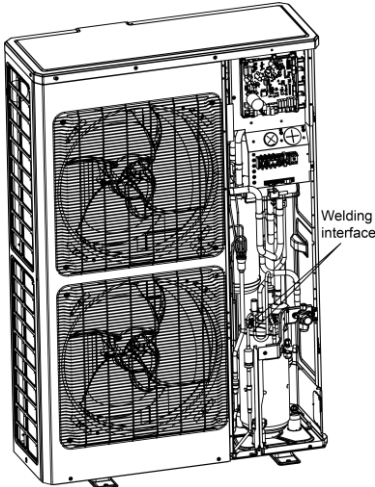
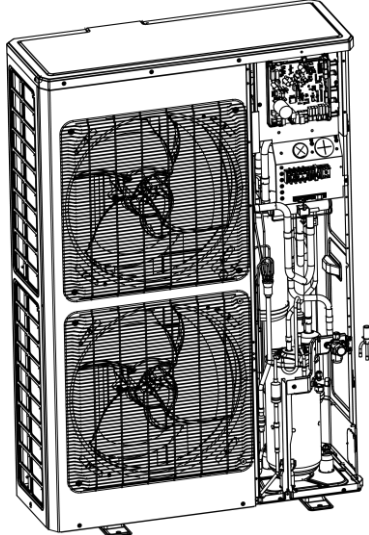
Removal of electronic expansion valve		
Note: Before removing the electronic expansion valve, make sure there is no refrigerant in the pipeline and power is cut off.		
Step	Picture	Work instruction
2. Remove the electric box.		<ul style="list-style-type: none"> •The connection wires inside and outside the electric box should be removed. •When removing the electric box, be careful to protect the components.
3. Remove the electronic expansion valve.		<ul style="list-style-type: none"> •Take off the coil of electronic expansion valve. •Loosen the connection pipe of electronic expansion valve by welding. Then remove the connection pipe. <p>Note: When welding the pipe, do not let the flame bunt the other components.</p>
4. Take out the electronic expansion valve.		<ul style="list-style-type: none"> •Take out the electronic expansion valve.

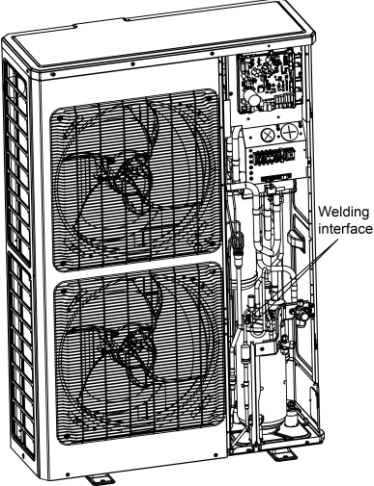
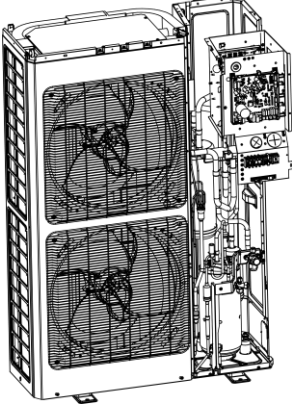
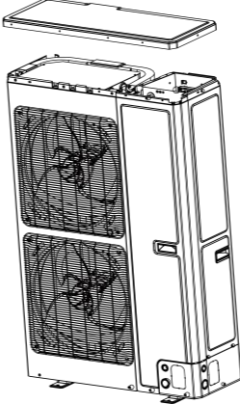
Removal of electronic expansion valve		
Note: Before removing the electronic expansion valve, make sure there is no refrigerant in the pipeline and power is cut off.		
Step	Picture	Work instruction
5. Install the new electronic expansion valve.		<ul style="list-style-type: none"> ●Weld the connection pipe of electronic expansion valve. ●When welding the electronic expansion valve, the valve should be wrapped with wet cloth. ●Nitrogen welding: the pressure of nitrogen is $0.5\pm 0.1\text{kgf/cm}^2$ (relative pressure). Note: When welding the pipes, do not let the flame burn the other components. ●Install the coil of electronic expansion valve.
6. Secure the electric box and arrange the wires as required.		<ul style="list-style-type: none"> ●Put the electric box back in place and tighten up the screws. ●Arrange the wires as original.
7. Check and open the upper and side panels.		<ul style="list-style-type: none"> ●Check whether each component and connection wire is well connected. ●If everything is OK, install the upper, left and right panels. Tighten up the screws.

4.5.2 Removal of IDU Major Components

4.5.2.1 Cassette Type Unit

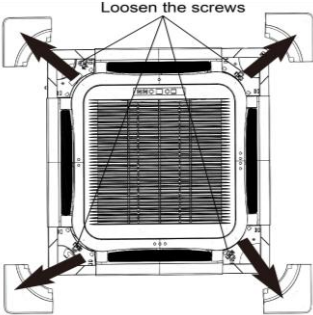
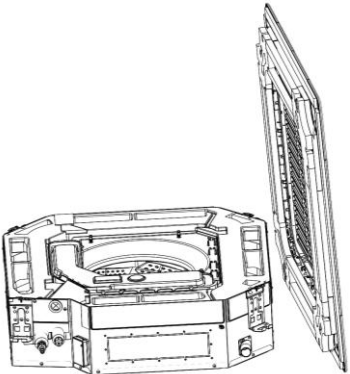
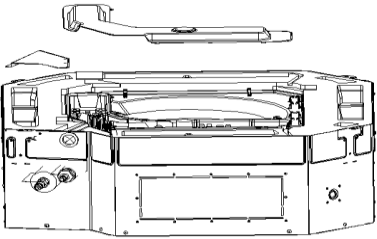
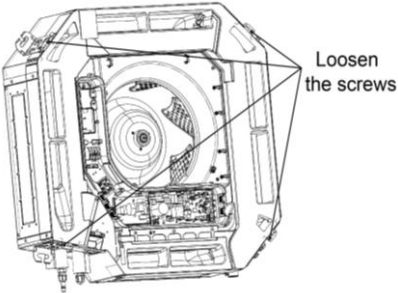
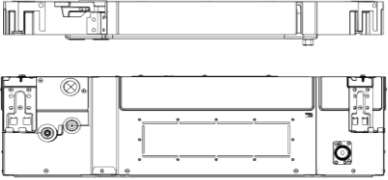
Removal of fan and motor		
Note: Before removing the motor, power must be cut off.		
Step	Picture	Work instruction
1. Remove the front panel.		<ul style="list-style-type: none"> ● Turn off the power supply of indoor unit. ● Push the 4 corner plates in the directions shown by the arrows. ● Loosen the screws and remove the front panel.
		
2. Remove the cover of electric box and the clamp of power cord.		<ul style="list-style-type: none"> ● Remove the motor wire and water pump of the electric box.
4. Remove the water tray.		<ul style="list-style-type: none"> ● Loosen the screws in the 4 corners and then remove the water tray.
		

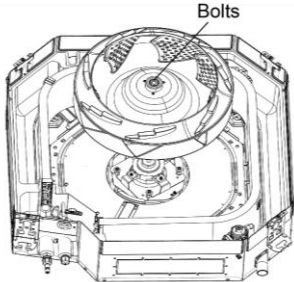
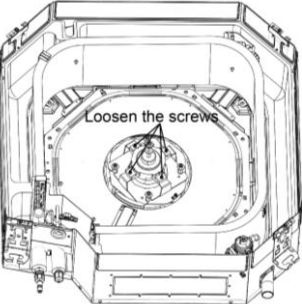
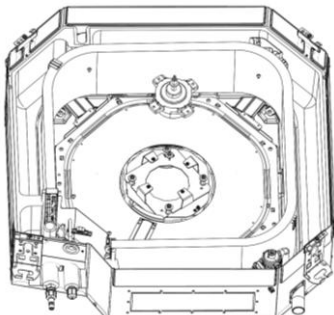
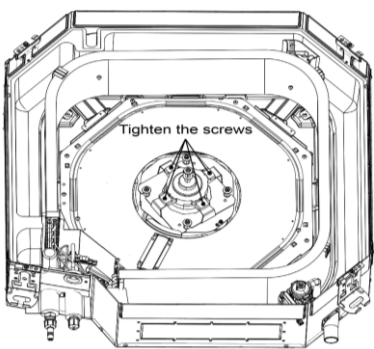
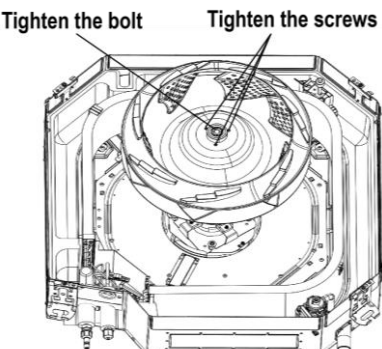
Removal of fan and motor		
Note: Before removing the motor, power must be cut off.		
Step	Picture	Work instruction
5. Remove the fan.		<ul style="list-style-type: none"> ●Use a screwdriver to remove the clamping band of motor. Then remove the fan.
6. Remove motor.		<ul style="list-style-type: none"> ●Use a screwdriver to unscrew the 4 screws of motor. Then remove the motor.
		
7. Replace and install the motor.		<ul style="list-style-type: none"> ●Remove the motor from motor support and then replace with a new motor. ●Tighten the 4 screws of motor with a screwdriver.
8. Install the fan.		<ul style="list-style-type: none"> ●Direct the hole of fan to the motor shaft and then mount on the fan. ●Tighten the clamping band of motor with a wrench.

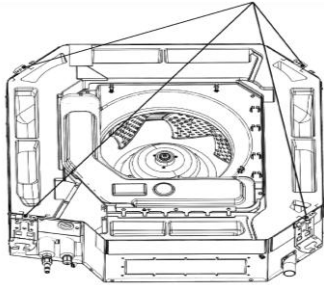
Removal of fan and motor		
Note: Before removing the motor, power must be cut off.		
Step	Picture	Work instruction
9. Install the water tray.	<p>Tighten the screws</p> 	<ul style="list-style-type: none"> ●Direct the 4 corners of water tray to the 4 corners of the unit and then press them. Use a screwdriver to tighten the screws in the 4 corners. ●Connect the power cord and water pump wire. ●Place back the cover of electric box and the clamp of power cord. Then tighten the screws with a screwdriver.

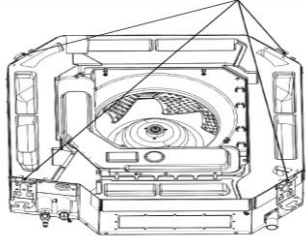
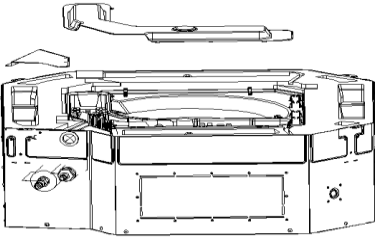
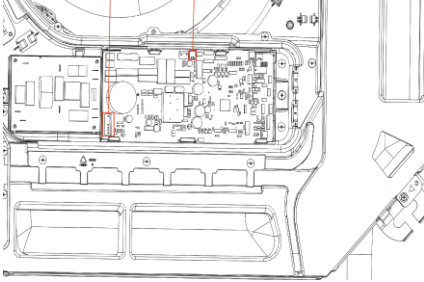
Removal and installation of drain pump		
Step	Picture	Work instruction
1. After removing the front panel as instructed above, loosen the screws of the water tray.	<p>Loosen the screws</p> 	<ul style="list-style-type: none"> ●Use a screwdriver to loosen the screws of water tray.
2. Remove the cover of electric box and the clamp of power cord.		<ul style="list-style-type: none"> ●Twist off the screws and open the cover of electric box and the clamp of power cord.
3. Remove the motor wire and water pump wire.	<p>Motor wiring port Pump wiring port</p> 	<ul style="list-style-type: none"> ●Remove the motor wire and water pump wire in the electric box.

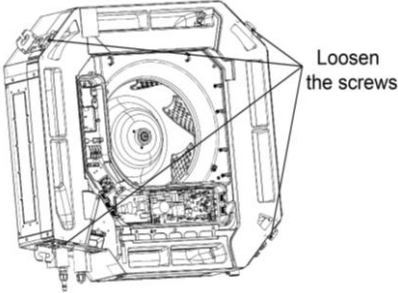
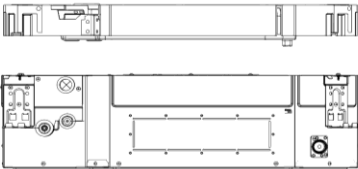
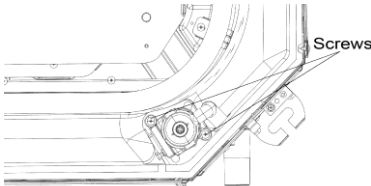
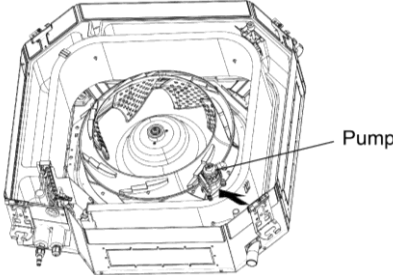
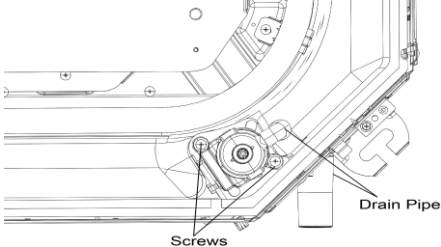
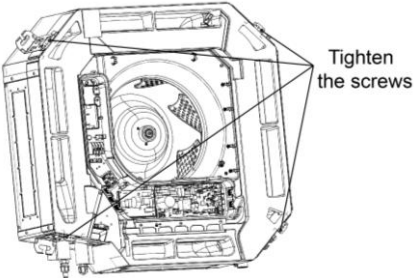
Removal and installation of drain pump		
Step	Picture	Work instruction
2. Remove the water tray.		<ul style="list-style-type: none"> ●Loosen the screws in the 4 corners and then remove the water tray.
		
3. Remove the drain pipe and loosen the screws of water pump.		<ul style="list-style-type: none"> ●Take out the drain pipe and use a screwdriver to loosen the screws of water pump.
4. Remove and replace the pump.		<ul style="list-style-type: none"> ●Remove the pump and replace with a new one.
5. Connect the drain pipe and tighten the screws of water pump.		<ul style="list-style-type: none"> ●Connect the drain pipe and tighten the screws of water pump.
6. Install the water tray and tighten the screws.		<ul style="list-style-type: none"> ●Direct the 4 corners of the water tray to the 4 corners of the unit and press them. Then use a screwdriver to tighten the screws.

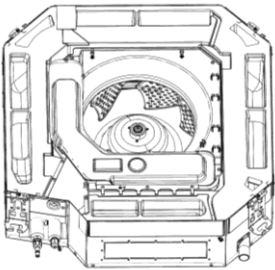
Removal and installation of drain pump		
Step	Picture	Work instruction
7. Connect the water pump wire and power cord, and then put back the cover of electric box and the clamp of power cord.		<ul style="list-style-type: none"> ●Connect the water pump wire and motor wire according to the wiring diagram. ●Put back the cover of electric box and the clamp of power cord. Then tighten the screws.

4.5.2.2 Duct Type Unit

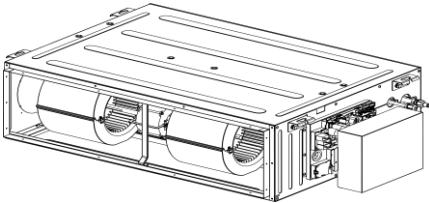
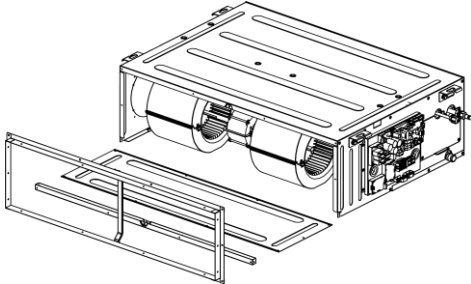
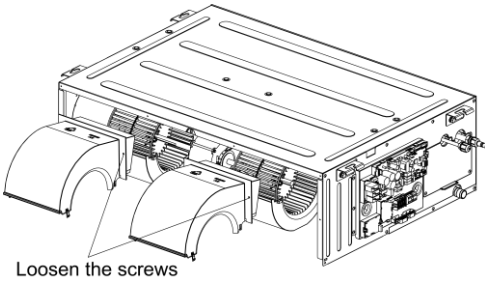
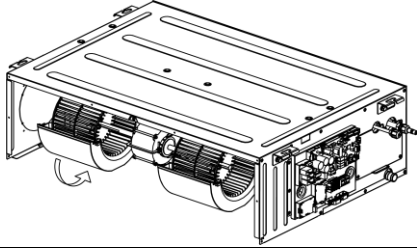
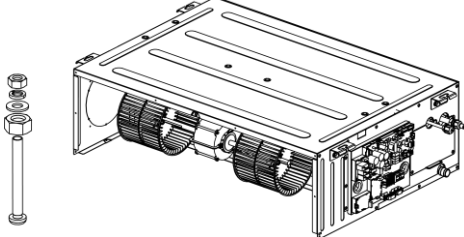
Removal of fan and motor		
Note: Before removing the motor, make sure power is cut off.		
Step	Picture	Work instruction
1. Remove the cover of electric box.		<ul style="list-style-type: none"> ●Turn off the power supply of indoor unit. Use a screwdriver to remove the cover of electric box. Disconnect the motor wire inside the electric box.
2. Remove air return plate, the longitudinal component and air return frame.		<ul style="list-style-type: none"> ●Use a hex wrench to loosen the screws of fan. ●Order of removal: air return plate, air return frame, longitudinal component, cross beam
3. Remove the upper volute.		<ul style="list-style-type: none"> ●Loosen the screws of upper volute and then pull out the upper volute.
4. Remove the lower volute.		<ul style="list-style-type: none"> ●Loosen the screws of lower volute and then rotate in the direction shown by the arrow.
5. Remove the motor and fan.		<ul style="list-style-type: none"> ●Use a screwdriver to remove the clamping band of motor. Then remove the motor and fan as a whole.

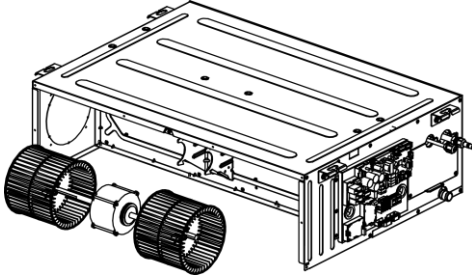
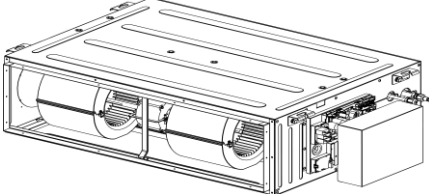
Removal of fan and motor		
Note: Before removing the motor, make sure power is cut off.		
Step	Picture	Work instruction
6. Replace the motor.		<ul style="list-style-type: none"> ●Remove the motor from the motor support. ●Use a hex wrench to loosen the screws of fan. ●Remove the fan from the motor. ●Replace with a new motor.
7. Re-install the device in a reverse order of the removal procedure.		<ul style="list-style-type: none"> ●Re-install the device in a reverse order of the removal procedure. Then connect power and test it.

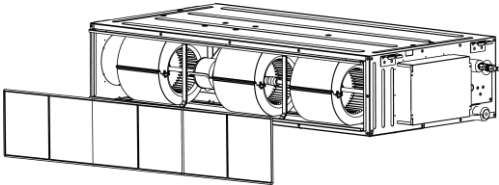
Removal of air return filter		
Note: Before removal, make sure power is cut off. During the removal procedure, take good care of all the components. Do not place the filter near any heat source.		
Step	Picture	Work instruction
Remove air return filter.		<ul style="list-style-type: none"> ●Press the air return filters on the guide way sponge. There are 2 or 3 air return filters.

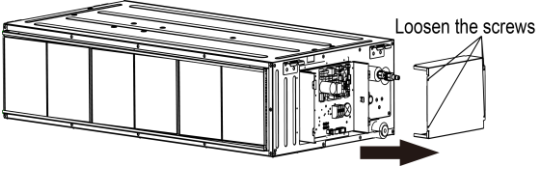
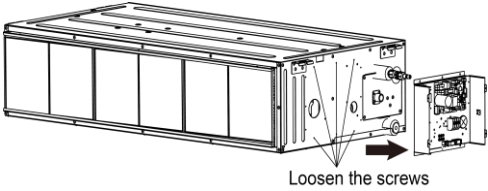
Removal of the cover of electric box and the electric box		
Note: Before removal, make sure power is cut off. During the removal procedure, take good care of all the components, especially the electric components. Do not hit or beat.		
Step	Picture	Work instruction
1. Remove the cover of electric box.		<ul style="list-style-type: none"> ●Loosen the screws as shown by the circle and the box. Remove the box in the direction shown by the arrow.
2. Remove the electric box.		<ul style="list-style-type: none"> ●Loosen the securing screws and remove the electric box.

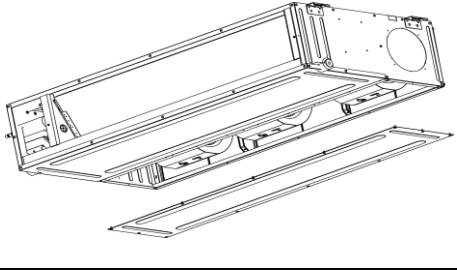
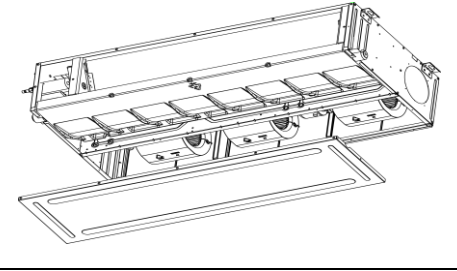
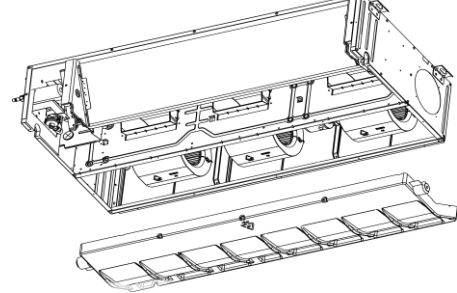
Removal of water tray		
Note: Before removal, make sure power is cut off. During the removal procedure, take good care of all the components.		
Step	Picture	Work instruction
1.Remove the cover plate.		<ul style="list-style-type: none"> ●Loosen the screws of cover plate and then remove the cover plate. (As shown in the picture, the circle indicates 6 screws of the cover plate.)
		
2. Remove the water tray.		<ul style="list-style-type: none"> ●Loosen the screws of water trap. Pull it up and remove it. The removed water tray is as shown in the picture.

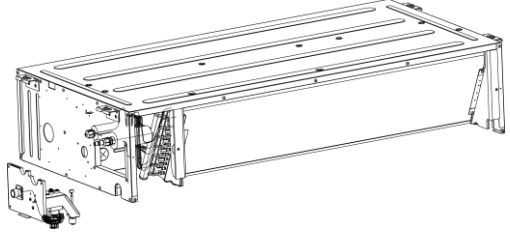
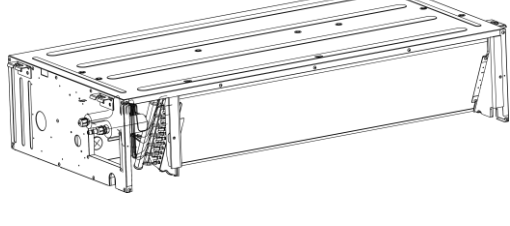
Removal of evaporator		
Note: Make sure power is cut off. Take good care of the copper pipe and aluminum fins. If the removal takes a long time, please put the copper pipe under pressure.		
Step	Picture	Work instruction
1. Remove the screws on the side plate of evaporator.		<ul style="list-style-type: none"> ●Remove the screws of evaporator and the screws that connect the upper cover plate to the left and right side plates.
2. Remove the sealing plate the connects to the evaporator valve and the screws that connect to the flange.		<ul style="list-style-type: none"> ●Remove the screws of the sealing plate of valve. Then remove the sealing plate of valve. Remove the screws that connect the evaporator to the flange.

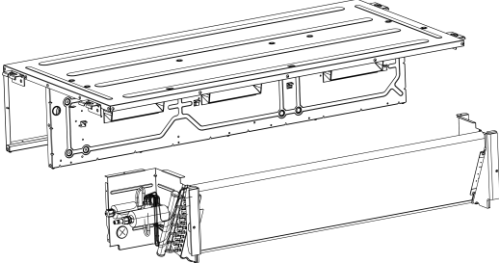
Removal of evaporator		
<p>Note: Make sure power is cut off. Take good care of the copper pipe and aluminum fins. If the removal takes a long time, please put the copper pipe under pressure.</p>		
Step	Picture	Work instruction
<p>3. Remove the evaporator.</p>		<ul style="list-style-type: none"> Take off the evaporator. The removed evaporator is as shown in the picture.

4.5.2.3 Floor Ceiling Unit

Take model GUD160ZD/A-T as an example.

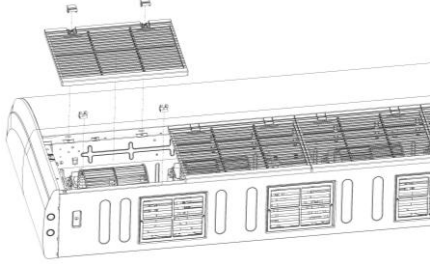
Removal of front grill		
<p>Note: Before removal, make sure power is cut off. During the removal procedure, take good care of all the components. Do not place the filter near any heat source.</p>		
Step	Picture	Work instruction
<p>Remove the sub-assembly of front grill.</p>		<ul style="list-style-type: none"> Twist off the 2 hooks of the grill and the screws of the hooks. Open the grill and remove 2 lower clamps. Then remove the grill.

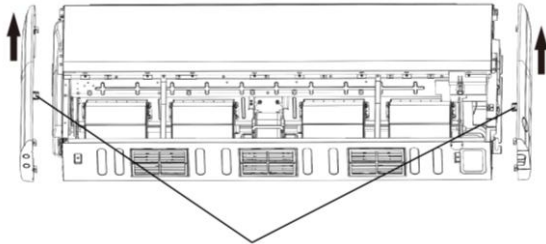
Remove the right and left decorative boards		
<p>Note: Before removal, make sure power is cut off. During the removal procedure, take good care of all the components. Do not scratch the appearance components.</p>		
Step	Picture	Work instruction
<p>Remove the left and right panels.</p>		<ul style="list-style-type: none"> Use a screwdriver to loosen the screws, as shown in the picture. Then pull the right and left panels upward. (Lines in the picture indicate the positions of screws.)

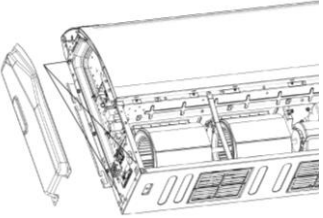
Removal of electric box assembly		
<p>Note: Before removal, make sure power is cut off. During the removal procedure, take good care of all the components, especially the components in electric box. Protect it from water and collision.</p>		
Step	Picture	Work instruction
Remove the electric box.		<ul style="list-style-type: none"> •Unscrew 34 screws as shown in the left picture and then remove the electric box.

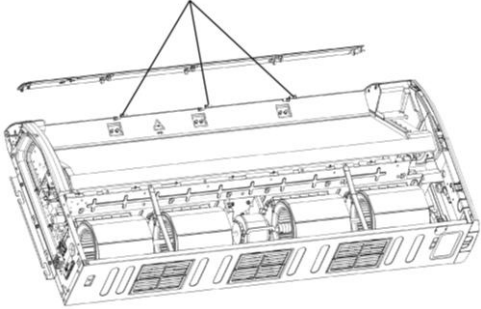
Removal of air guide louver		
<p>Note: Before removal, make sure power is cut off. During the removal procedure, take good care of all the components, especially the connectors of air guide louver.</p>		
Step	Picture	Work instruction
Remove the air guide louver assembly.		<ul style="list-style-type: none"> •Remove the air guide louver from its supporting assembly. Then take off the connectors from the swing motor. (As shown in the picture, the lines indicate the supporting assembly.)

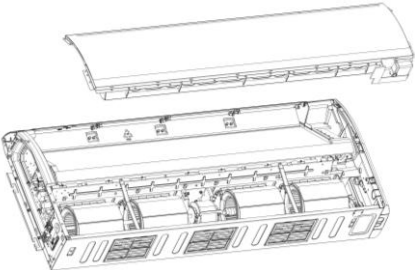
Removal of water tray		
<p>Note: Before removal, make sure power is cut off. During the removal procedure, take good care of all the components.</p>		
Step	Picture	Work instruction
Remove the water tray.		<ul style="list-style-type: none"> •Remove the water tray.

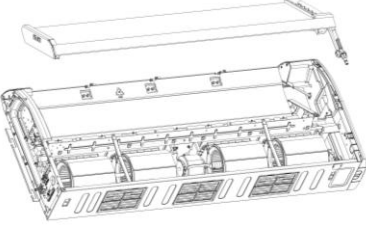
Removal of evaporator		
<p>Note: Make sure power is cut off. Take good care of the copper pipe and aluminum fins. If the removal takes a long time, seal the copper pipe.</p>		
Step	Picture	Work instruction
<p>Remove the evaporator assembly.</p>		<ul style="list-style-type: none"> • Twist off the 6 screws of the evaporator, 3 screws of the plate board of water releasing flume, and 2 screws of the water tray. Then remove the evaporator.

Removal of display panel and fan assembly		
<p>Note: Before removal, make sure power is cut off. During the removal procedure, take good care of all the components.</p>		
Step	Picture	Work instruction
<p>Remove the display panel and fan assembly.</p>		<ul style="list-style-type: none"> • First remove the display panel, next the bracket and then the swing motor mounting plate.

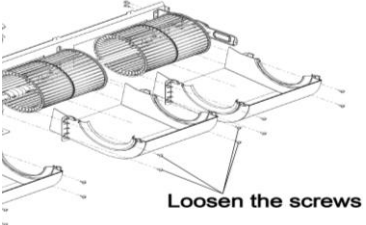
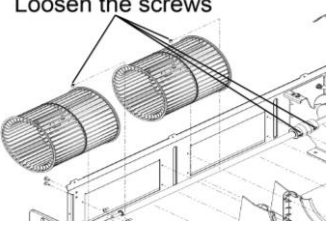
Removal of fan and motor		
<p>Note: Before removal, make sure power is cut off. During the removal procedure, take good care of all the components, especially the screws of fan.</p>		
Step	Picture	Work instruction
<p>1. Remove the volutes.</p>		<ul style="list-style-type: none"> • Press the retaining ring at the joint of front and rear volutes. Then pull up the front volute. Then loosen the screws of the rear volute. Lift up the retaining ring of the rear volute and take it off. (As shown in the picture, the lines indicate the screws on both sides of the volutes.)
<p>2. Remove the fan.</p>		<ul style="list-style-type: none"> • Loosen the 2 screws of the coupler. Take out the shaft and axial flow fan. Loosen the screws of axial flow fan and remove the axial flow fan.

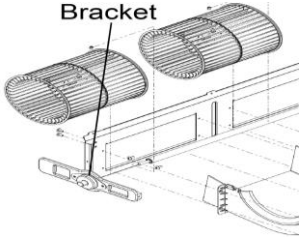
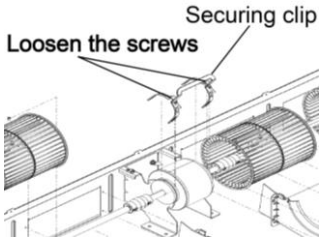
Removal of fan and motor		
Note: Before removal, make sure power is cut off. During the removal procedure, take good care of all the components, especially the screws of fan.		
Step	Picture	Work instruction
3. Remove the bearing fixed plate.		<ul style="list-style-type: none"> ● Twist off the screws and nuts of bracket. Then remove the bracket.
4. Remove the motor		<ul style="list-style-type: none"> ● Loosen the 2 screws of the motor securing clip. Remove the motor securing clip and its assembly.

4.6 Explosive View and Lists of Parts

4.6.1 ODU Explosive View and Lists of Parts

GUD35W/NhA-T(Product Code: CF090W1310)

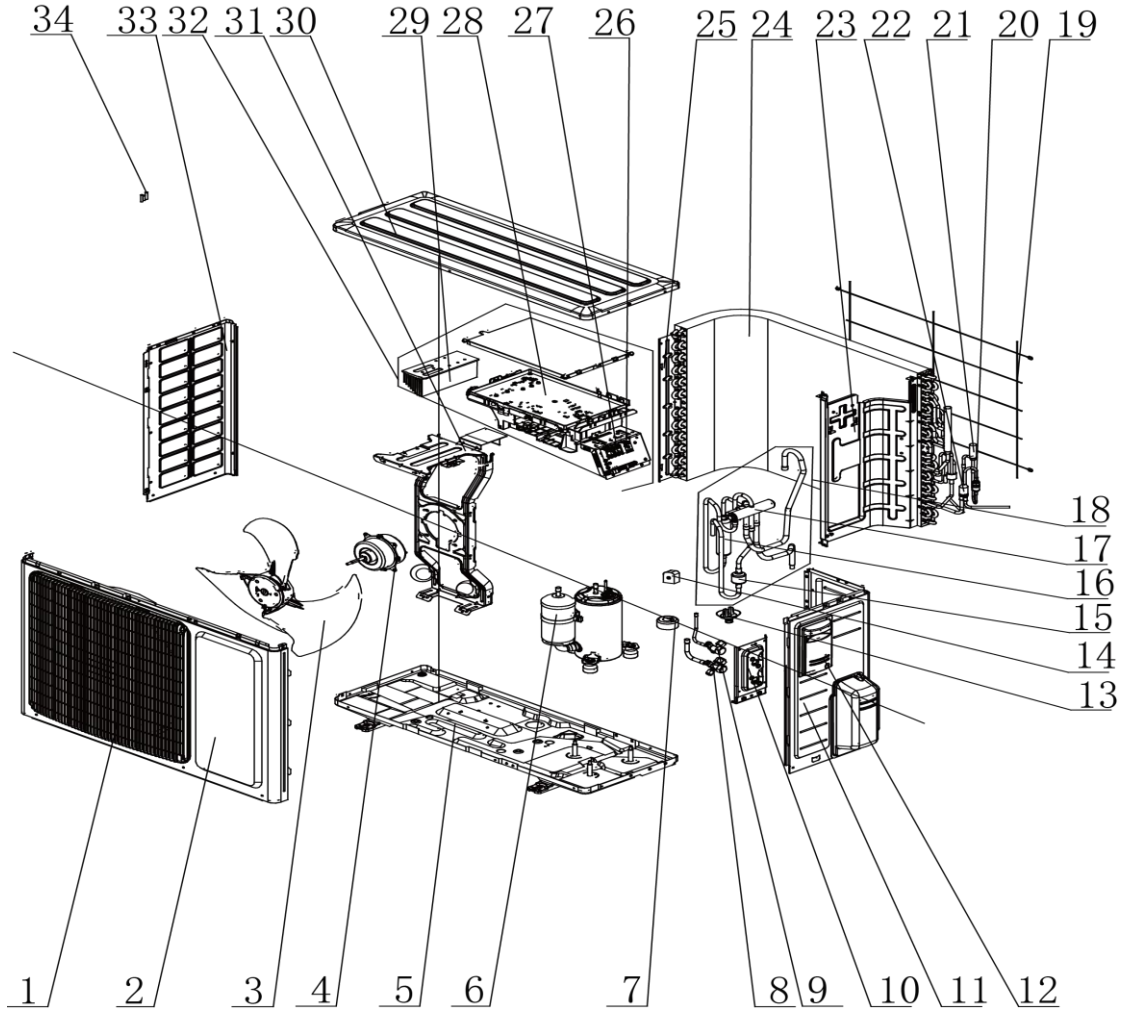

No.	Material name	Finished Product Code	Quantity
1	Front Grill	22413046	1
2	Cabinet	01433034P	1
3	Axial Flow Fan	10333011	1
4	Fan Motor	1501308511	1
5	Base Plate Sub-assay	17000060107	1
6	Compressor and Fittings	9001060093	1
7	Electric Expand Valve Fitting	4300034401	1
8	Cut off Valve	71302395	1
9	Cut off Valve	7130239	1
10	Valve Support Sub-assay	01713115P	1
11	Right Side Plate	0130324403P	1
12	Big Handle	2623343106	1
13	Drainage Joint	26113009	1
14	4 Way Valve Coil	4300040087	1
15	Silencer	7245013	1
16	Silencer 1	7243050	1
17	4-way Valve	430004032	1
18	4-way Valve Assay	30152060099	1
19	Rear Grill	1473060	1
20	Strainer	7225088	1
21	Electronic Expansion Valve	7133821	1
22	Strainer	721302608	1
23	Clapboard Sub-assay	1233168	1
24	Condenser Assay	11002060290	1
25	Condenser Support Plate	1795028	1
26	Terminal Board	42200000000701	1
27	Terminal Board	42200000002402	1
28	Main Board	300027060151	1
29	Radiator	49013060	1
30	Coping	012049000006P	1
31	Motor Support Sub-Assay	1703180	1
32	Electric Box Assay	100002061298	1
33	Left Side Plate	01303169P	1
34	Temperature Sensor	3900028020G	1

GUD50W/NhA-T(Product Code: CF090W1210)

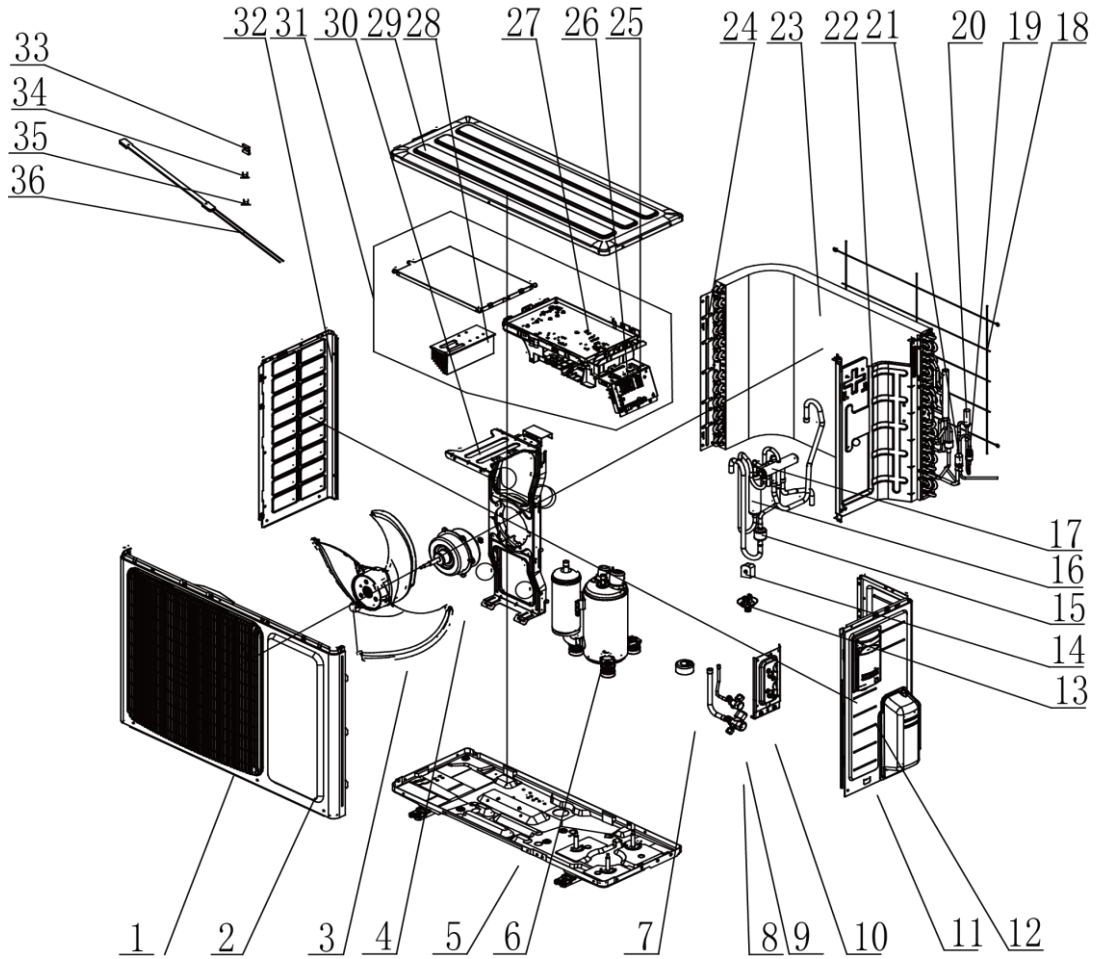

No.	Material name	Finished Product Code	Quantity
1	Front Grill	22413046	1
2	Cabinet	01433034	1
3	Axial Flow Fan	10333014	1
4	Fan Motor	1501371701	1
5	Base Plate Sub-assy	017000060100	1
6	Compressor and Fittings	009001060006	1
7	Electric Expand Valve Fitting	4300034401	1
8	Cut off Valve	071302392	1
9	Cut off Valve	07130239	1
10	Valve Support Sub-assy	01713115	1
11	Right Side Plate	0130324403	1
12	Big Handle	2623343106	1
13	Drainage Joint	26113009	1
14	4 Way Valve Coil	4300040087	1
15	Silencer	07245013	1
16	Silencer 1	07243050	1
17	4-way Valve	430004032	1
18	Rear Grill	01473060	1
19	Strainer	07225088	1

No.	Material name	Finished Product Code	Quantity
20	Electronic Expansion Valve	07133821	1
21	Strainer	0721302608	1
22	Clapboard Sub-assay	01233168	1
23	Condenser Assy	011002060290	1
24	Condenser Support Plate	01795028	1
25	Terminal Board	422000000007	1
26	Terminal Board	42200000002402	1
27	Main Board	300027060151	1
28	Radiator	49013060	1
29	Coping	012049000006	1
30	Motor Support Sub-assay	0170339802	1
31	Electric Box Assy	100002061297	1
32	Left Side Plate	01303169	1 </td
33	Temperature Sensor	3900007201	1
34	Compressor Overload Protector(External)	00183051	1
35	Compressor Overload Protector(External)	00183032	1

GUD71W/NhA-T (Product Code: CF090W1220)

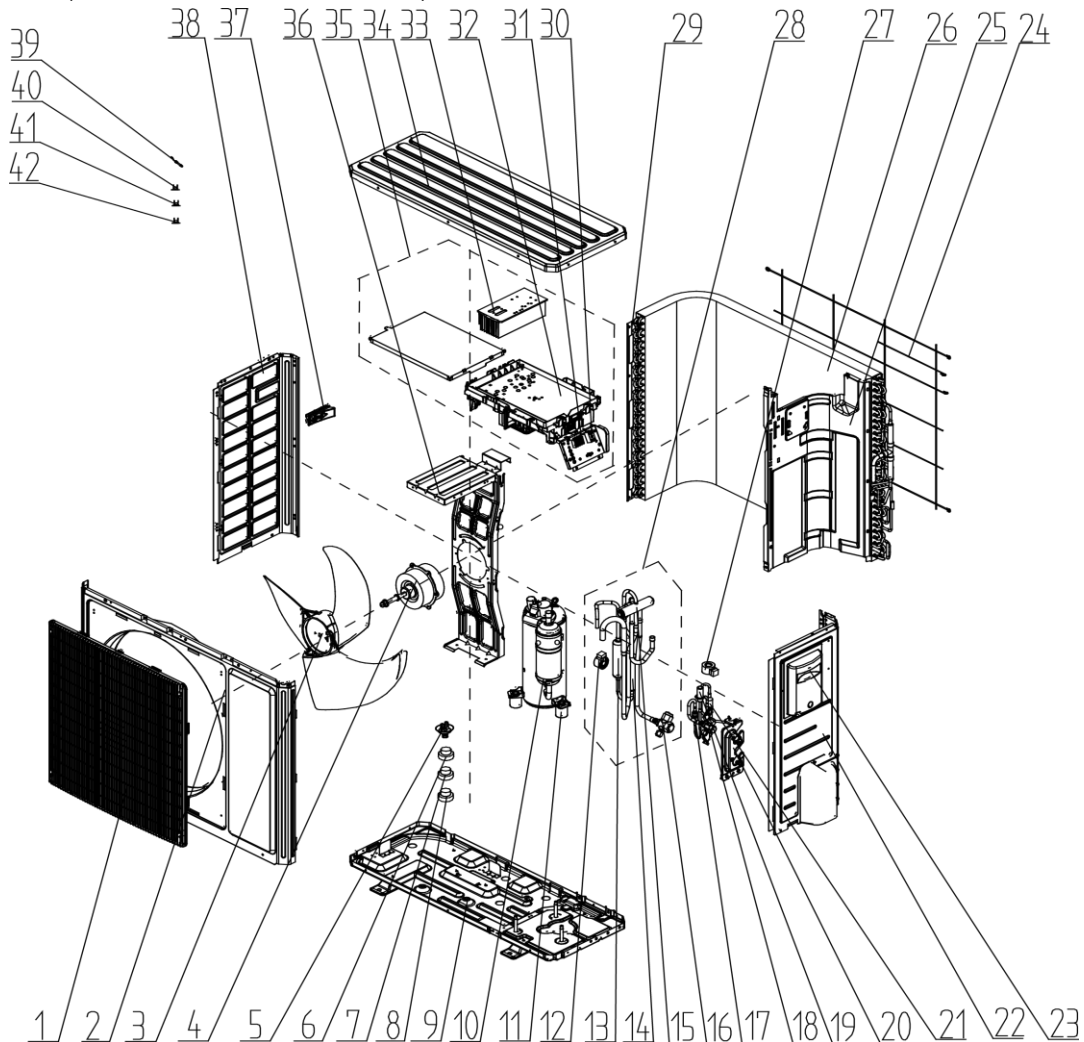

No.	Material name	Finished Product Code	Quantity
1	Front Grill	22415010	1
2	Front Panel	01535013	1
3	Axial Flow Fan	10335008	1
4	Fan Motor	1501506402	1
5	Drainage Joint	06123401	1
6	Drainage hole Cap	76713033	1
7	Drainage hole Cap	76713068	1
8	Drainage hole Cap	06813401	1
9	Base Plate Sub-assay	01205816	1
10	Compressor and Fittings	00900100019501	1
11	Compressor Gasket	009012000004	3
12	4 Way Valve Coil	4300040087	1
13	Silencer1	07243050	1
14	Silencer2	07243049	1
15	4-way Valve	430004032	1
16	Cut off Valve	07133844	1
17	Strainer	0721302608	1
18	Cut off Valve	071302391	1
19	Electronic Expansion Valve	072009000004	1
20	Valve Support Sub-assay	01705046	1
21	Strainer	07225088	1
22	Right Side Plate	0130509001	1
23	Handle	2623525404	1
24	Rear Grill	01475020	1
25	Clapboard Sub-assay	01235081	1
26	Condenser Assay	011002000177	1
27	Electric Expand Valve Fitting	43000344	1
28	4-way Valve Assay	030152060086	1
29	Condenser Support Plate	01795031	1
30	Terminal Board	422000000007	1
31	Terminal Board	42200000002402	1
32	Main Board	300027060157	1
33	Radiator	4901521502	1
34	Top Cover Sub-assay	000051000017	1
35	Electric Box Assay	100002061278	1
36	Motor Support Sub-assay	01705067	1
37	Handle	26233053	1
38	Left Side Plate	01305093	1
39	Temperature Sensor	3900007201	1
40	Compressor Overload Protector(External)	00180030	1
41	Compressor Overload Protector(External)	00183032	1
42	Compressor Overload Protector(External)	00183031	1

GUD85W/NhA-T(Product Code: CF090W1230)

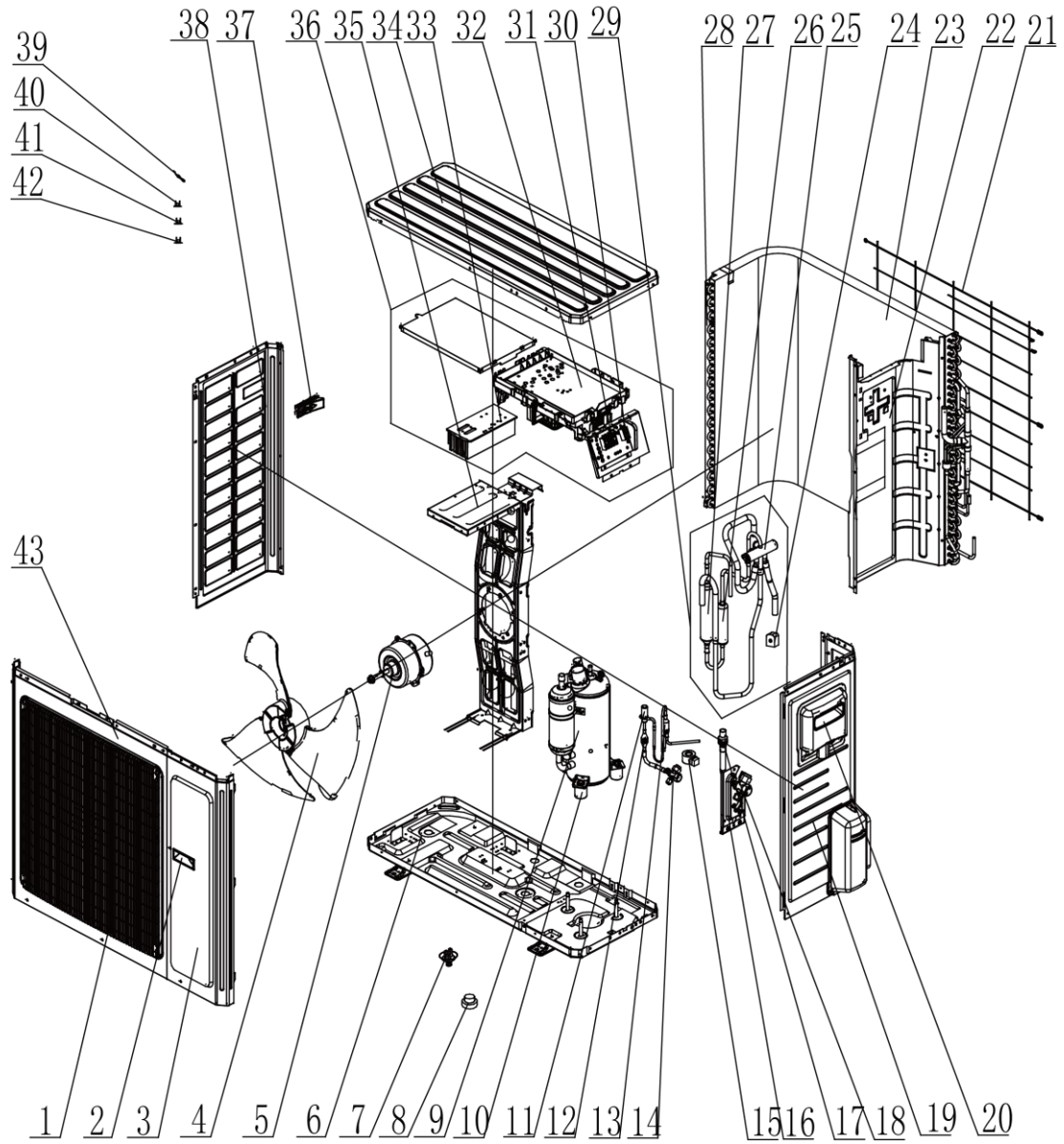

No.	Material name	Finished Product Code	Quantity
1	Front Grill	22415011	1
2	Left Handle	26235401	1
3	Front Side Plate	01305086	1
4	Axial Flow Fan	10335014	1
5	Fan Motor	15010400000102	1
6	Base Plate Sub-assay	0280319601	1
7	Drainage Joint	06123401	1
8	Drainage hole Cap	06813401	3
9	Compressor and Fittings	00900100019501	1
10	Compressor Gasket	009012000004	3
11	Electronic Expansion Valve	072009000004	1
12	Strainer	07215201	1
13	Strainer	07225088	1
14	Cut off Valve	071302391	1
15	Electric Expand Valve Fitting	43000344	1
16	Valve Support Sub-assay	0171501201	1
17	Strainer	0721304401	1
18	Cut off Valve	07133157	1
19	Right Side Plate	0130504401	1
20	Big Handle	26235001	1
21	Rear Grill	01475013	1
22	Clapboard Sub-assay	01235091	1
23	Condenser Assay	01100200162	1
24	Magnet Coil	4300040045	1
25	4-way Valve	4300008201	1
26	Silencer1	07243050	1
27	Silencer	07245101	1
28	Condenser Support Plate	01175092	1
29	4-way Valve Assay	030152000329	1
30	Terminal Board	422000000007	1
31	Terminal Board	42200000002402	1
32	Main Board	300027060157	1
33	Radiator	4901521502	1
34	Coping	01255020	1
35	Electric Box Assay	100002061294	1
36	Motor Support Sub-assay	017012000017	1
37	Handle	26233053	1
38	Left Side Plate	01305043	1
39	Temperature Sensor	3900007201	1
40	Compressor Overload Protector(External)	00183031	1
41	Compressor Overload Protector(External)	00183032	1
42	Compressor Overload Protector(External)	00180030	1
43	Cabinet	01435004	1

GUD100W/NhA-T(Product Code: CF090W1240)

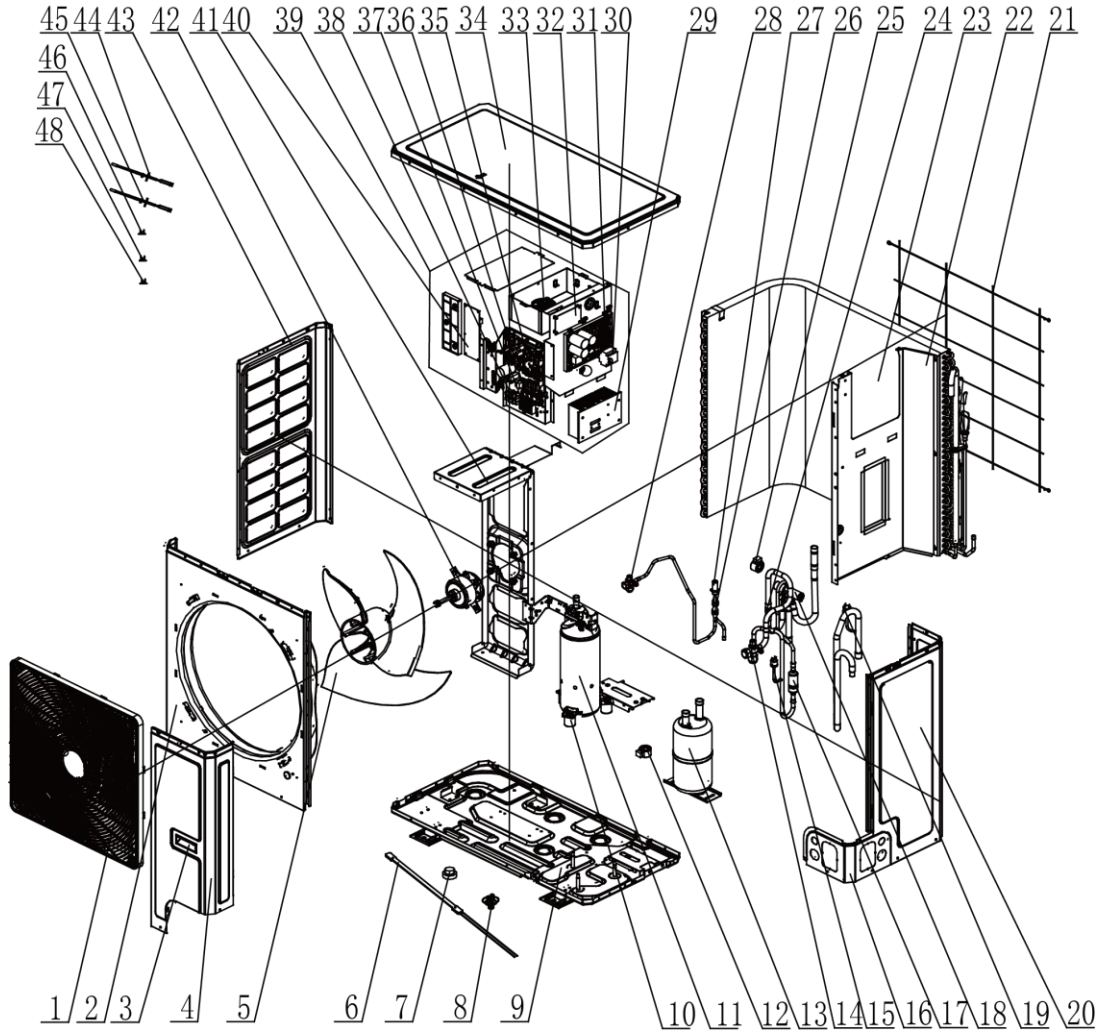

No.	Material name	Finished Product Code	Quantity
1	Front Grill	01572800003	1
2	Cabinet	012022000003	1
3	Handle	26904100016	2
4	Front Side Plate	012050000007	1
5	Axial Flow Fan	1043410000801	1
6	Electric Heater (Compressor)	7651873215	1
7	Drainage hole Cap	76715005	3
8	Drainage Joint	26113009	1
9	Base Plate Sub-assay	017000060073	1
10	Filter Board	300020000004	1
10	Compressor and Fittings	009001000231	1
11	Compressor Gasket	009012000004	1
12	Electric Expand Valve Fitting	43000344	1
13	Gas-liquid Separator	07423902	1
14	Cut off Valve	07334100016	1
15	Pressure Protect Switch	4602000603	1
16	Connection Board	01344100070	1
17	Silencer	07245012	1

No.	Material name	Finished Product Code	Quantity
18	4-way Valve	4300008201	1
19	Pressure Protect Switch	46020007	1
20	Rear Side Plate	012076000021	1
21	Rear Grill	01574100014	1
22	Clapboard Sub-assay	017021060074	1
23	Condenser Assay	011002060190	1
24	Filter	07224803	1
25	4-way Valve Coil	4300040087	1
26	Strainer	0721304401	2
27	Electronic Expansion Valve	072009000018	1
28	Cut off Valve	071302391	1
29	Radiator	430034000048	1
30	Inductance	43128000014	1
31	Main Board	30221000024	1
32	Power Switch	300012060010	1
33	PFC Inductance	43120011	1
34	Coping	01264100052	1
35	Main Board	300027060156	1
36	Terminal Board	422000000007	1
37	Terminal Board	42000100000101	1
38	Terminal Board	42200000001501	1
39	Electric Box Assay	100002061299	1
41	Motor Support	012048000023	1
42	Fan Motor	150104060013	1
43	Left Side Plate	012055000007	1
44	Temperature Sensor	3900007201	1
45	Temperature Sensor	39008000049G	1
46	Compressor Overload Protector(External)	00183032	1
47	Compressor Overload Protector(External)	00183031	1
48	Compressor Overload Protector(External)	00180030	1

GUD125W/NhA-T(Product Code: CF090W1260)

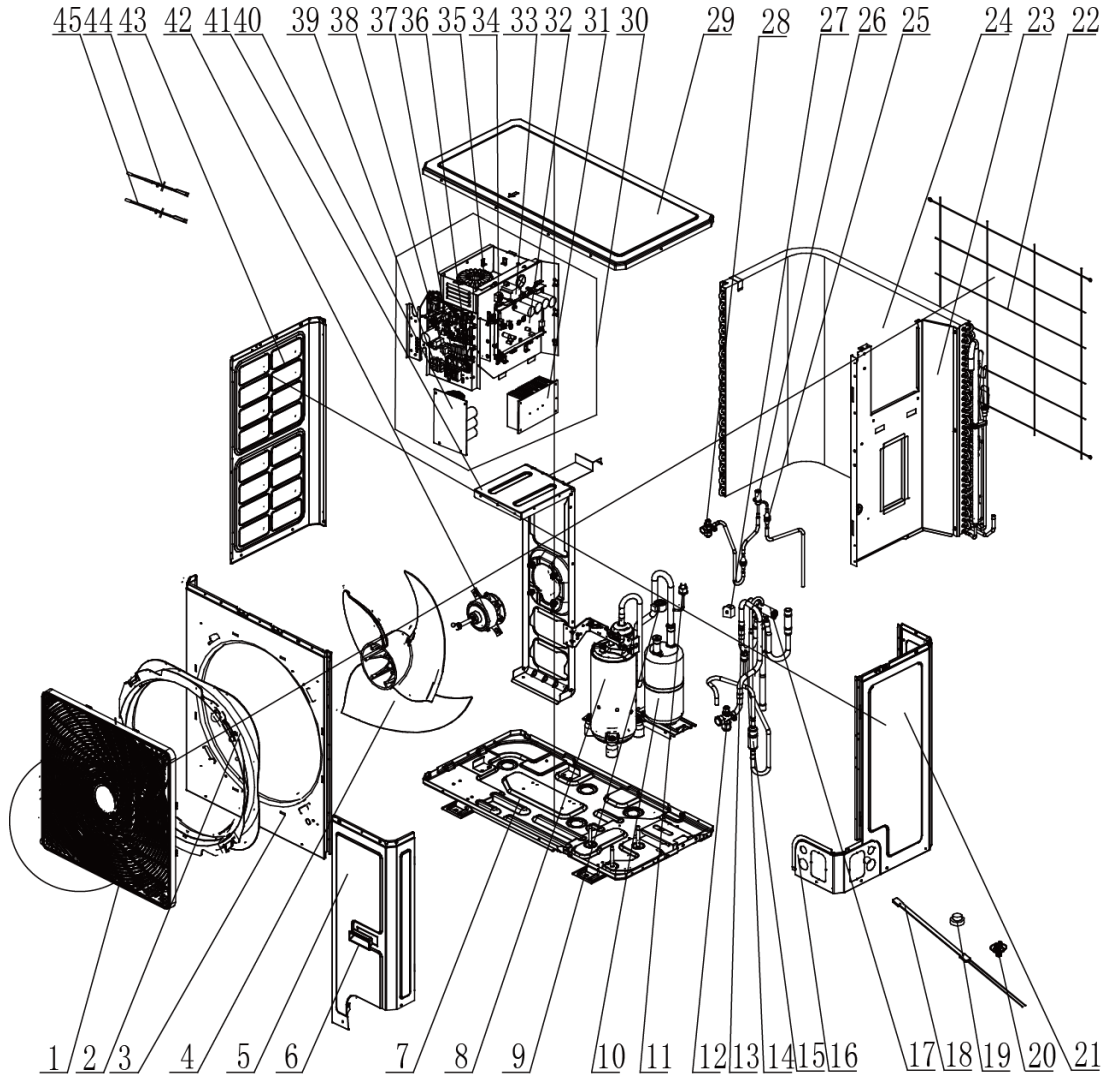

No.	Material name	Finished Product Code	Quantity
1	Front Grill	01572800003	1
2	Diversion Circle	10474100003	1
3	Cabinet	012022000003	1
4	Axial Flow Fan	1043410000801	1
5	Front Side Plate	012050000007	1
6	Handle	26904100016	2
7	Base Plate Sub-assay	01700006008901	1
8	Compressor and Fittings	009001060077	1
9	Electric Expand Valve Fitting	43000344	1
10	Gas-liquid Separator	07423902	1
11	Pressure Protect Switch	46020007	1
12	Cut off Valve	07334100016	1
13	Filter	07224803	1
14	Pressure Protect Switch	4602000603	1
15	Silencer	07245012	1
16	Connection Board	01344100070	1
17	4-way Valve	4300008201	1

No.	Material name	Finished Product Code	Quantity
18	Electric Heater (Compressor)	7651521238	1
19	Drainage hole Cap	76715005	3
20	Drainage Joint	26113009	1
21	Rear Side Plate	012076000021	1
22	Rear Grill	01574100014	1
23	Clapboard Sub-assay	017021060074	1
24	Condenser Assay	011002060190	1
25	Strainer	0721304401	2
26	Electronic Expansion Valve	43005017	1
27	Magnet Coil	4300040045	1
28	Cut off Valve	071302391	1
29	Coping	01264100052	1
30	Electric Box Assay	100002061303	1
31	Radiator	49018000013	1
32	Main Board	300027060292	1
33	Inductance	4312800001401	1
34	Terminal Board	42011147	1
35	PFC Inductance	43120122	1
36	Main Board	300027060156	1
37	Terminal Board	422000000007	1
38	Terminal Board	42000100000101	1
39	Terminal Board	42200000001501	1
40	Filter Board	300020000003	1
41	Motor Support	012048000023	1
42	Fan Motor	150104060013	1
43	Left Side Plate	012055000007	1
44	Temperature Sensor	3900007201	1
45	Temperature Sensor	39008000049G	1

GUD140W/NhA-T (Product Code: CF090W1280)

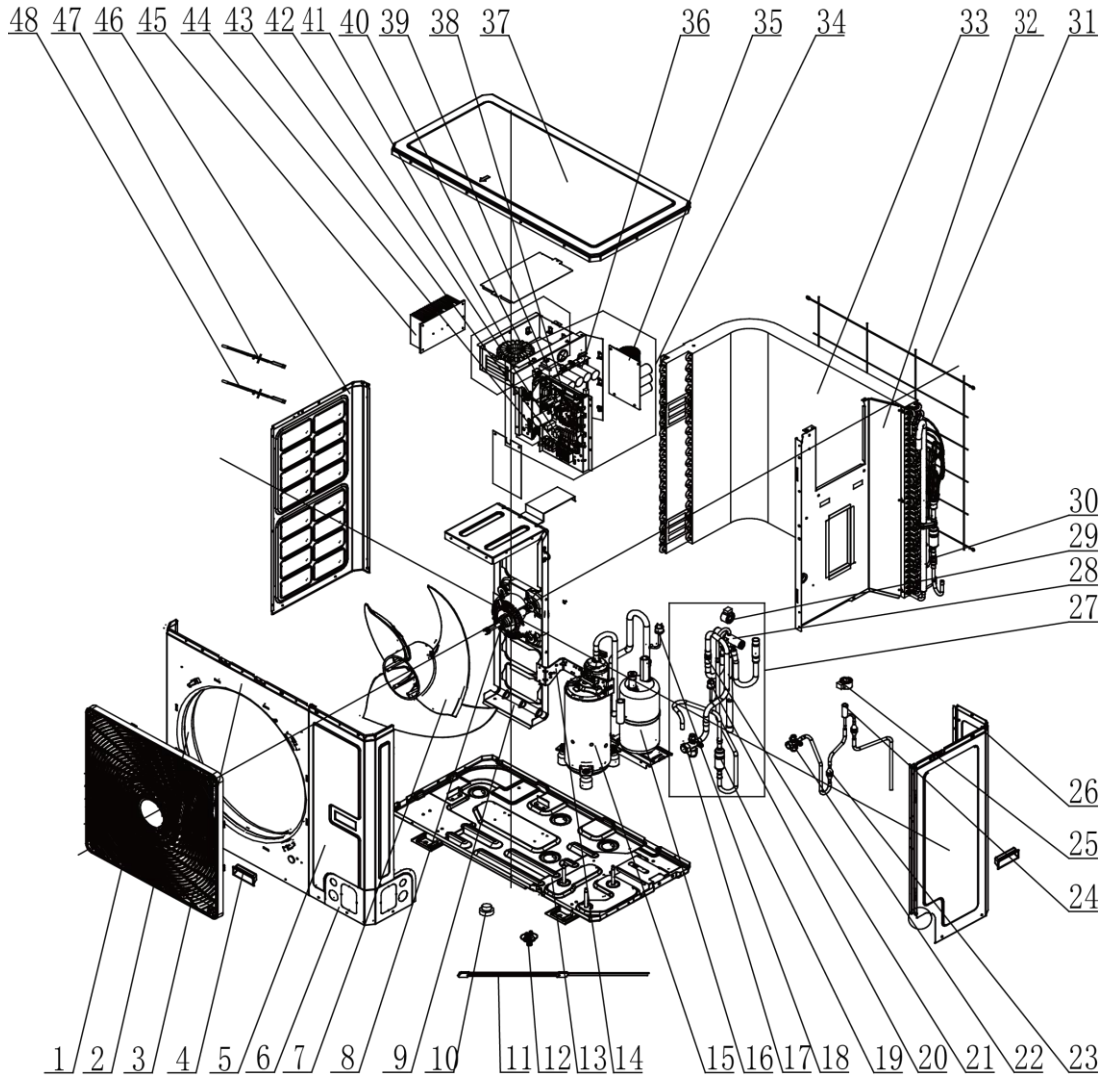

No.	Material name	Finished Product Code	Quantity
1	Front Grill	01572800003	1
2	Diversion Circle	10474100003	1
3	Cabinet	012022000003P	1
4	Handle	26904100016	1
5	Front Side Plate	012050000007	1
6	Connection Board	01344100070P	1
7	Axial Flow Fan	1043410000801	1
8	Fan Motor	150104060013	1
9	Motor Support Sub-assay	017012060039	1
10	Drainage hole Cap	76715005	1
11	Electrical Heater(Compressor)	7651521238	1
12	Drainage Joint	26113009	1
13	Base Plate Sub-assay	017000060089	1
14	Valve Support Sub-assay	017104000008	1
15	Compressor and Fittings	009001060077	1
16	Gas-liquid Separator	07423902	1
17	Cut off Valve	07334100016	1

No.	Material name	Finished Product Code	Quantity
18	Pressure Protect Switch	46020007	1
19	Silencer	07245012	1
20	Pressure Protect Switch	4602000603	1
21	Filter	07224803	1
22	Cut off Valve	071302391	1
23	Strainer	0721304401	2
24	Electronic Expansion Valve	43005017	1
25	Electric Expand Valve Fitting	43000344	1
26	Rear Side Plate	012076000021	1
27	4-way Valve Assay	030152060078	1
28	4-way Valve	4300008201	1
29	Magnet Coil	4300040045	1
30	Strainer	0721212101	1
31	Rear Grill	01574100014	1
32	Clapboard Sub-assay	017021060074	1
33	Condenser Assay	01100200031501	1
34	Electric Box Assay	100002061303	1
35	Filter Board	300020000003	1
36	Main Board	300027060292	1
37	Coping	01264100052	1
38	Main Board	300027060156	1
39	Inductance	4312800001401	1
40	Terminal Board	42011147	1
41	Inductance	43120122	1
42	Terminal board	42000100000101	1
43	Terminal Board	422000000007	1
44	Terminal Board	42200000001501	1
45	Radiator	49018000013	1
46	Left Side Plate	012055000007P	1
47	Temperature Sensor	39008000049G	1
48	Temperature Sensor	3900007201	1

GUD100W/NhA-X(Product Code: CF090W1250)

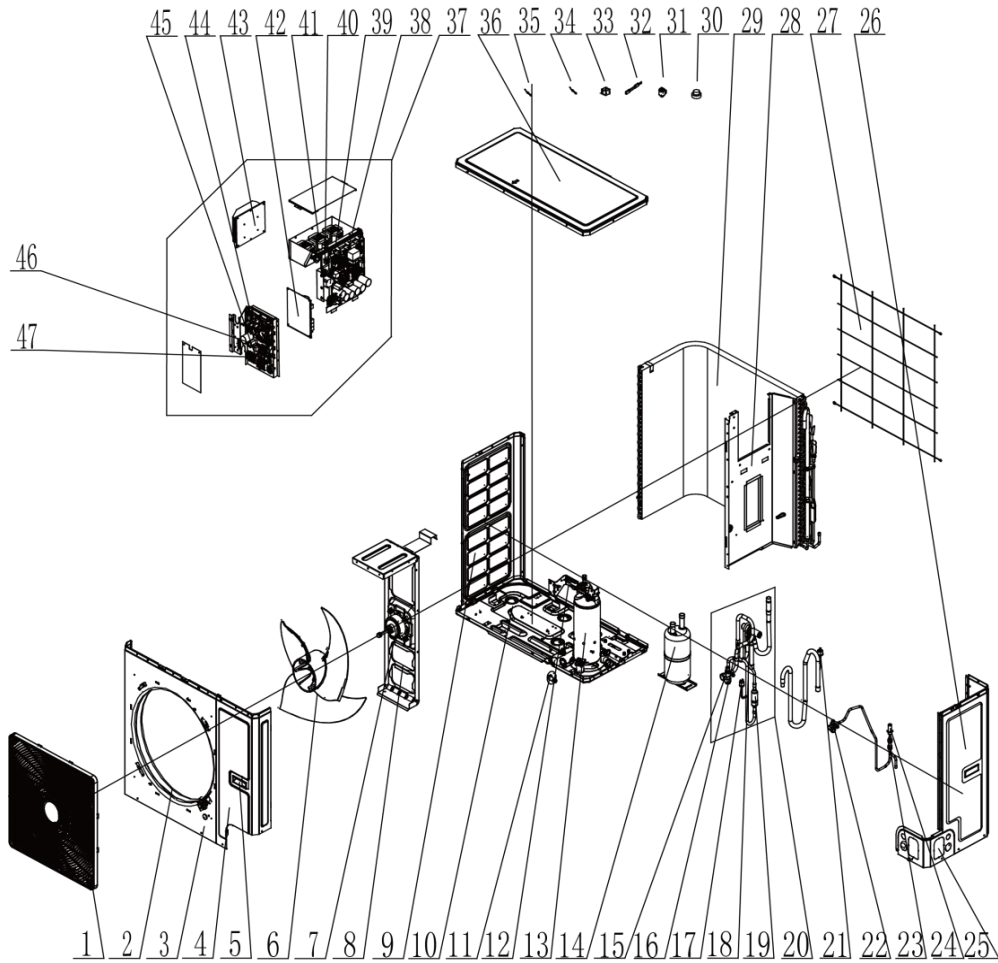

No.	Material name	Finished Product Code	Quantity
1	Front Grill	1572800003	1
2	Diversion Circle	10474100003	1
3	Cabinet	012022000003	1
4	Front Side Plate	012050000007	1
5	Handle	26904100016	1
6	Axial Flow Fan	1043410000801	1
7	Fan Motor	150104060013	1
8	Motor Support Sub-assay	01701206003901	1
9	Left Side Plate	012055000007	1
10	Base Plate Sub-assay	017000060073	1
11	Drainage Joint	26113009	1
12	Valve Support Sub-assay	017104000008	1
13	Compressor and Fittings	009001060078	1
14	Gas-liquid Separator	07423902	1
15	Cut off Valve	07334100016	1
16	Strainer	0721304401	1
17	Pressure Protect Switch	4602000603	1
18	4-way Valve	4300008201	1

No.	Material name	Finished Product Code	Quantity
19	Silencer	07245012	1
20	4-way Valve Assay	030152060080	1
21	Pressure Protect Switch	46020007	1
22	Cut off Valve	071302391	1
23	Strainer	0721304401	1
24	Electronic Expansion Valve	072009000018	1
25	Connection Board	01344100070	1
26	Rear Side Plate	012076000021	1
27	Rear Grill	01574100014	1
28	Clapboard Sub-assay	017021060074	1
29	Condenser Assay	011002060190	1
30	Drainage hole Cap	76715005	1
31	Electric Expand Valve Fitting	43000344	1
32	Electrical Heater(Compressor)	7651873215	1
33	4-way Valve Coil	4300040087	1
34	Temperature Sensor	39008000049G	1
35	Temperature Sensor	3900007201	1
36	Coping	01264100052	1
37	Electric Box Assay	100002061296	1
38	Main Board	300027060156	1
39	Inductance	43128000014	1
40	Terminal Board	42011147	1
41	Reactor	43130192	1
42	Filter Board	30223000044	1
43	Radiator	49018000087	1
44	Terminal board	42000100000101	1
45	Terminal Board	422000000007	1
46	Main Board	300027000436	1
47	Terminal Board	422000060009	1

GUD125W/NhA-X(Product Code: CF090W1270)

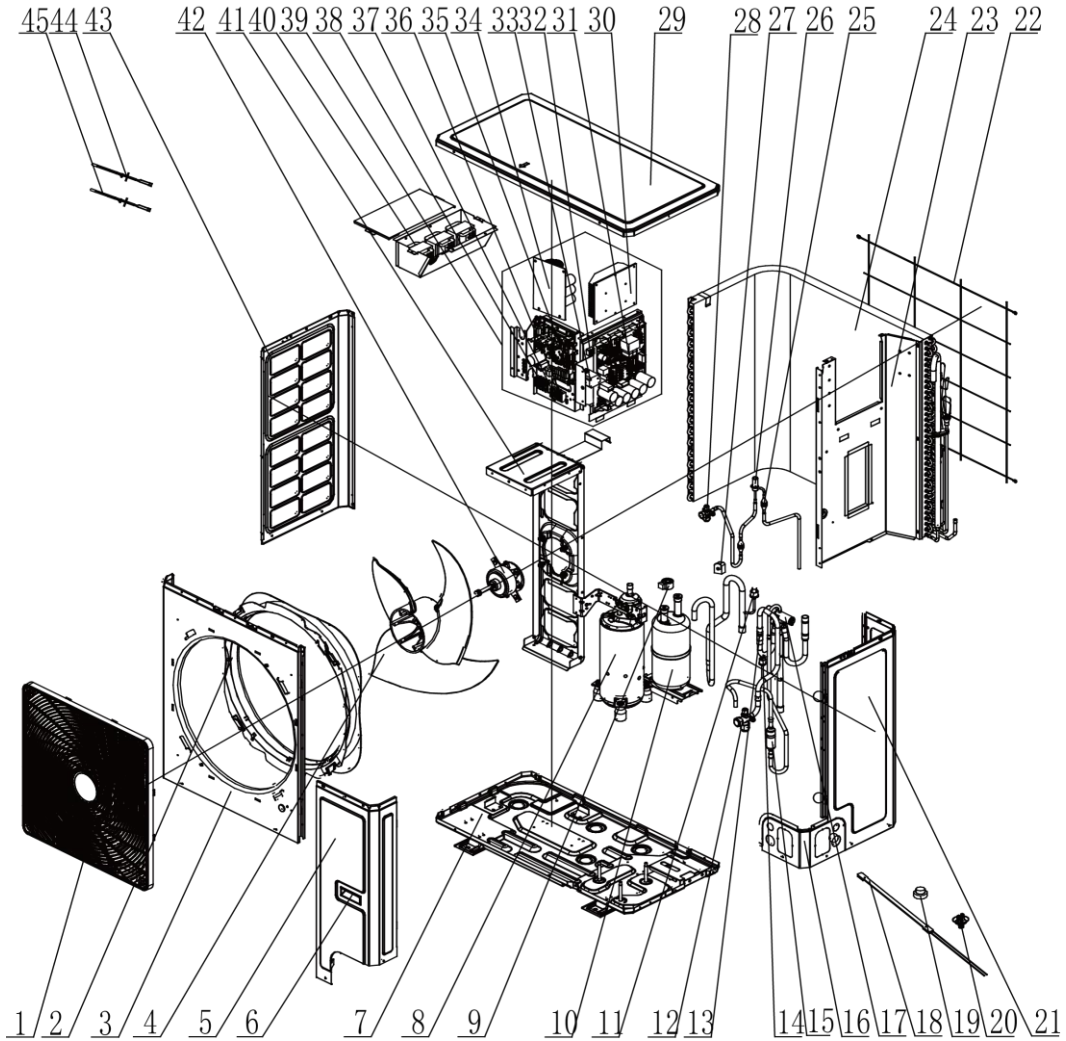

No.	Material name	Finished Product Code	Quantity
1	Front Grill	01572800003	1
2	Diversion Circle	10474100003	1
3	Cabinet	012022000003	1
4	Axial Flow Fan	1043410000801	1
5	Front Side Plate	012050000007	1
6	Handle	26904100016	1
7	Base Plate Sub-assay	01700006008901	1
8	Compressor and Fittings	009001060059	1
9	Electric Expand Valve Fitting	43000344	1
10	Gas-liquid Separator	07423902	1
11	Pressure Protect Switch	46020007	1
12	Cut off Valve	07334100016	1
13	Strainer	0721304401	1
14	Pressure Protect Switch	4602000603	1
15	Silencer	07245012	1
16	Connection Board	01344100070	1
17	4-way Valve	4300008201	1

No.	Material name	Finished Product Code	Quantity
18	Electrical Heater(Compressor)	7651521238	1
19	Drainage hole Cap	76715005	1
20	Drainage Joint	26113009	1
21	Rear Side Plate	012076000021	1
22	Rear Grill	01574100014	1
23	Clapboard Sub-assay	017021060074	1
24	Condenser Assay	011002060190	1
25	Strainer	721304401	2
26	Electronic Expansion Valve	43005017	1
27	Electric Expand Valve Fitting	43000344	1
28	Cut off Valve	71302391	1
29	Coping	01264100052	1
30	Radiator	49018000087	1
31	Main Board	300027000644	1
32	Terminal board	42011147	1
33	Inductance	43128000014	1
34	Filter Board	30223000044	1
35	Main Board	300027060156	1
36	Terminal Board	422000000007	1
37	Terminal Board	42000100000101	1
38	Terminal Board	422000060009	1
39	Electric Box Assay	100002061295	1
40	Reactor	43130192	1
41	Motor Support	012048000023	1
42	Fan Motor	150104060013	1
43	Left Side Plate	012055000007	1
44	Temperature Sensor	39008000049G	1
45	Temperature Sensor	3900007201	1

GUD140W/NhA-X(Product Code: CF090W1290)

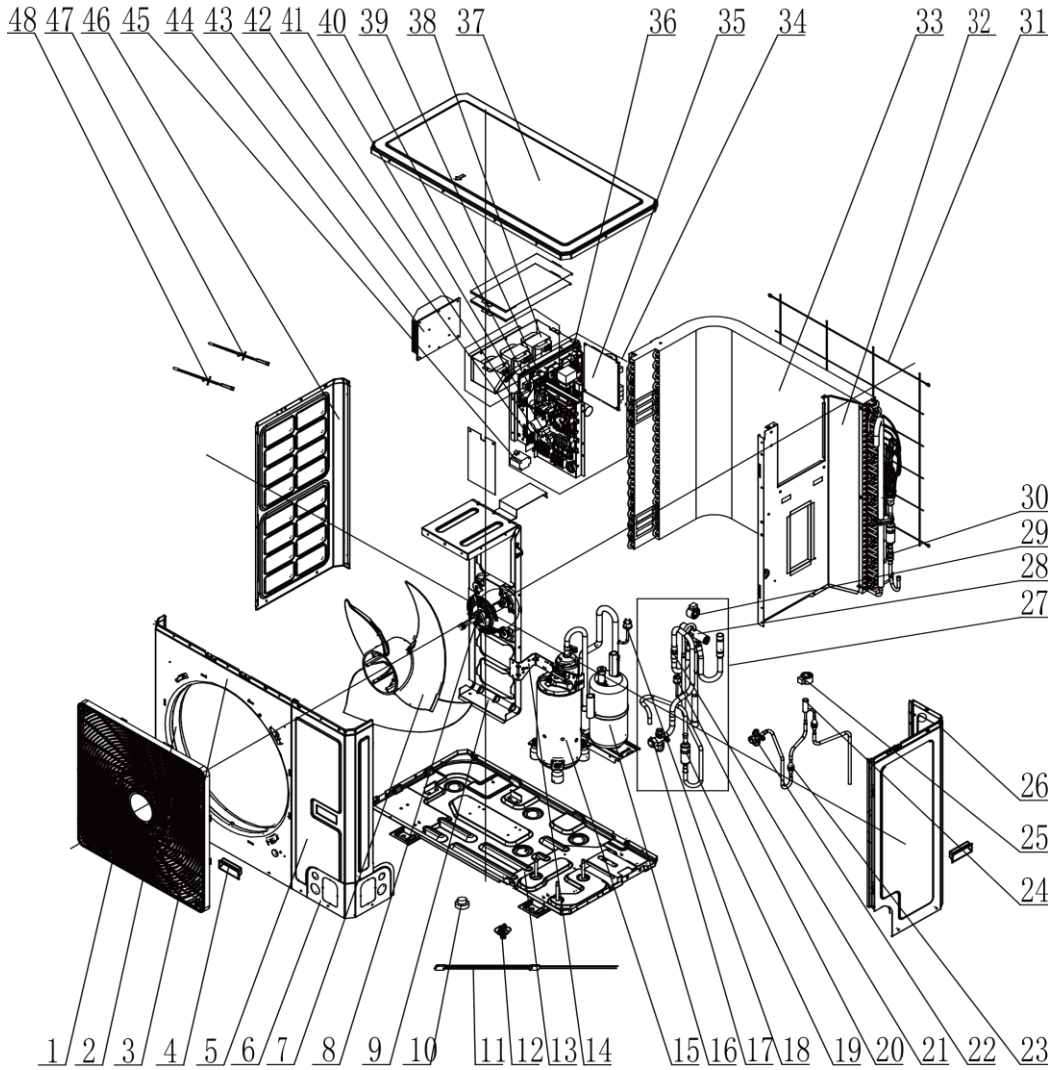

No.	Material name	Finished Product Code	Quantity
1	Front Grill	01572800003	1
2	Diversion Circle	10474100003	1
3	Cabinet	012022000003	1
4	Handle	26904100016	1
5	Front Side Plate	012050000007	1
6	Connection Board	01344100070	1
7	Axial Flow Fan	1043410000801	1
8	Fan Motor	150104060013	1
9	Motor Support Sub-assay	017012060039	1
10	Drainage Hole Cap	76715005	3
11	Electrical Heater(Compressor)	7651521238	1
12	Drainage Joint	26113009	1
13	Base Plate Sub-assay	017000060089	1
14	Valve Support Sub-assay	017104000008	1
15	Compressor and Fittings	009001060059	1
16	Gas-liquid Separator	07423902	1
17	Cut off Valve	07334100016	1

No.	Material name	Finished Product Code	Quantity
18	Pressure Protect Switch	46020007	1
19	Silencer	07245012	1
20	Pressure Protect Switch	4602000603	1
21	Filter	07224803	1
22	Cut off Valve	071302391	1
23	Strainer	0721304401	2
24	Electronic Expansion Valve	43005017	1
25	Electric Expand Valve Fitting	43000344	1
26	Rear Side Plate	012076000021	1
27	4-way Valve Assay	030152060078	1
28	4-way Valve	4300008201	1
29	Magnet Coil	4300040045	1
30	Strainer	0721212101	1
31	Rear Grill	01574100014	1
32	Clapboard Sub-assay	017021060074	1
33	Condenser Assay	01100200031501	1
34	Electric Box Assay	100002061295	1
35	Filter Board	30223000044	1
36	Main Board	300027060156	1
37	Coping	01264100052	1
38	Reactor	43130192	1
39	Main Board	300027000644	1
40	Terminal Board	42011147	1
41	Terminal Board	422000000007	1
42	Terminal Board	42000100000101	1
43	Terminal Board	422000060009	1
44	Radiator	49018000087	1
45	Inductance	43128000014	1
46	Left Side Plate	012055000007	1
47	Temperature Sensor	39008000049G	1
48	Temperature Sensor	3900007201	1

GUD160W/NhA-X(Product Code: CF090W1300)

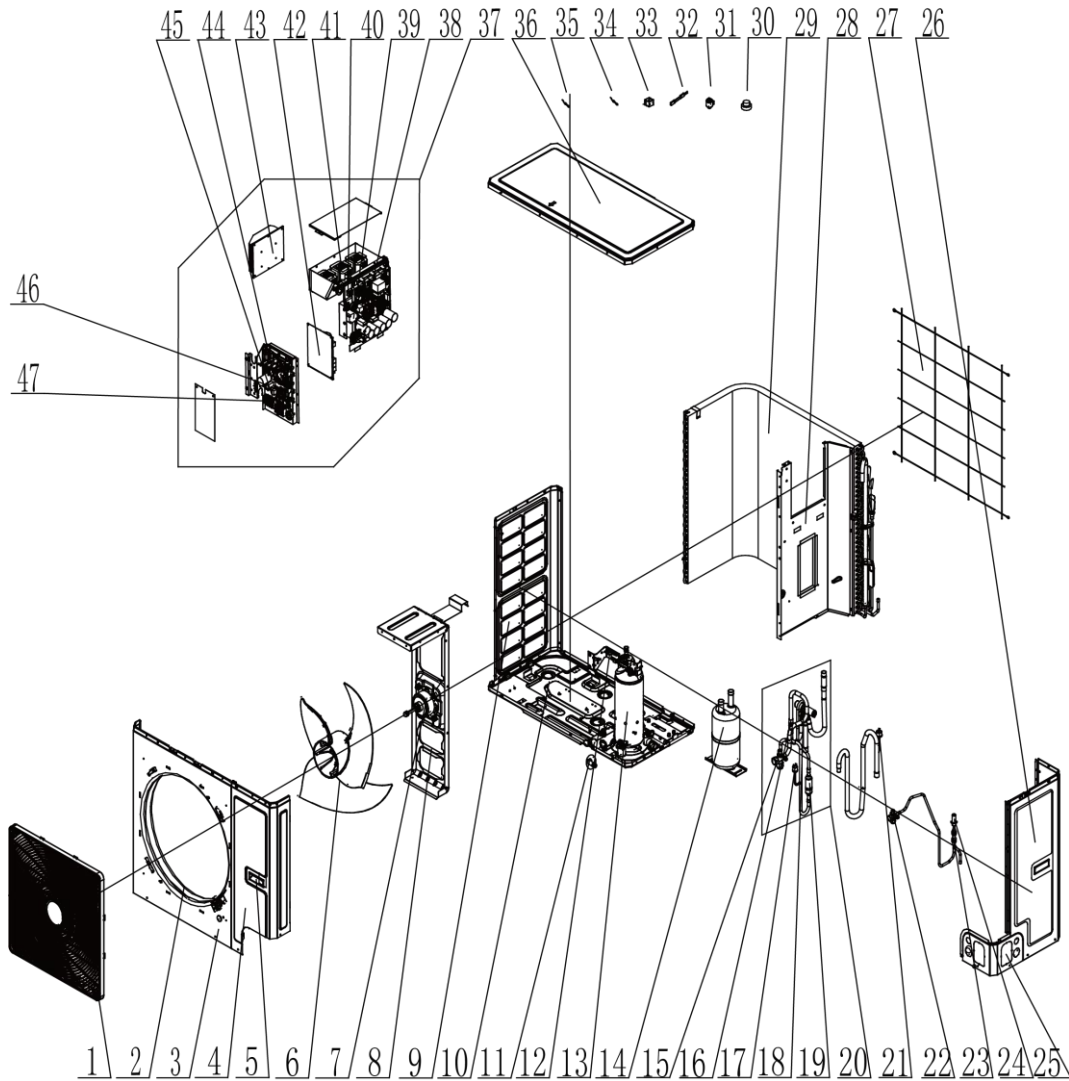

No.	Material name	Finished Product Code	Quantity
1	Front Grill	01575200002	2
2	Cabinet	01514100002	1
3	Diversion Circle	10474100001	2
4	Axial Flow Fan	1043410000301	1
5	Handle	26235253	1
6	Front Side Plate	01314100012	1
7	Brushless DC Motor	1570410001305	1
8	Brushless DC Motor	1570410001306	1
9	Electric Expand Valve Fitting	43000344	
10	Electronic Expansion Valve	43005017	1
11	Strainer	0741410000601	2
12	Base Plate Sub-assy	017000000342	1
13	Cut off Valve	07330000002	1
14	Compressor and Fittings	009001060059	1
15	Magnet Coil	4300040045	1
16	Cut off Valve	07334100016	1

No.	Material name	Finished Product Code	Quantity
17	Filter	07224803	1
18	4-way Valve	43000338	1
19	Pressure Protect Switch	4602000603	1
20	4-way Valve Assay	030152060082	1
21	Rear Side Plate Sub-assay	017051000057	1
22	Rear Grill	01574100004	1
23	Clapboard Sub-assay	017021060075	1
24	Strainer	0721212101	1
25	Condenser Assay	000100060046	1
26	Pressure Protect Switch	46020007	1
27	Gas-liquid Separator	0722501603	1
28	Electric Box Assay	100002062084	1
29	Inductance	43128000014	1
30	Filter Board	30223000044	1
31	Terminal Board	42011147	1
32	Terminal Board	422000000007	1
33	Main Board	300027060156	1
34	Terminal Board	42000100000101	1
35	Terminal Board	422000060009	1
36	Coping	01264100008	1
37	Radiator	49018000127	1
38	Main Board	300027000644	1
39	Reactor	43130192	1
40	Electric Box Assay	100002061300	1
41	Motor Support Sub-assay	017012000126	1
42	Left Side Plate	01314100013	1
43	Electrical Heater(Compressor)	765152128	1
44	Drainage Joint	06123401	1
45	Drainage Hole Cap	06813401	3
46	Temperature Sensor	3900007201	1
47	Temperature Sensor	3900028025G	1

4.6.2 IDU Explosive View and Lists of Parts

GUD35T/A-T(Product Code:), GUD50T/A-T(Product Code: ET010N1540)

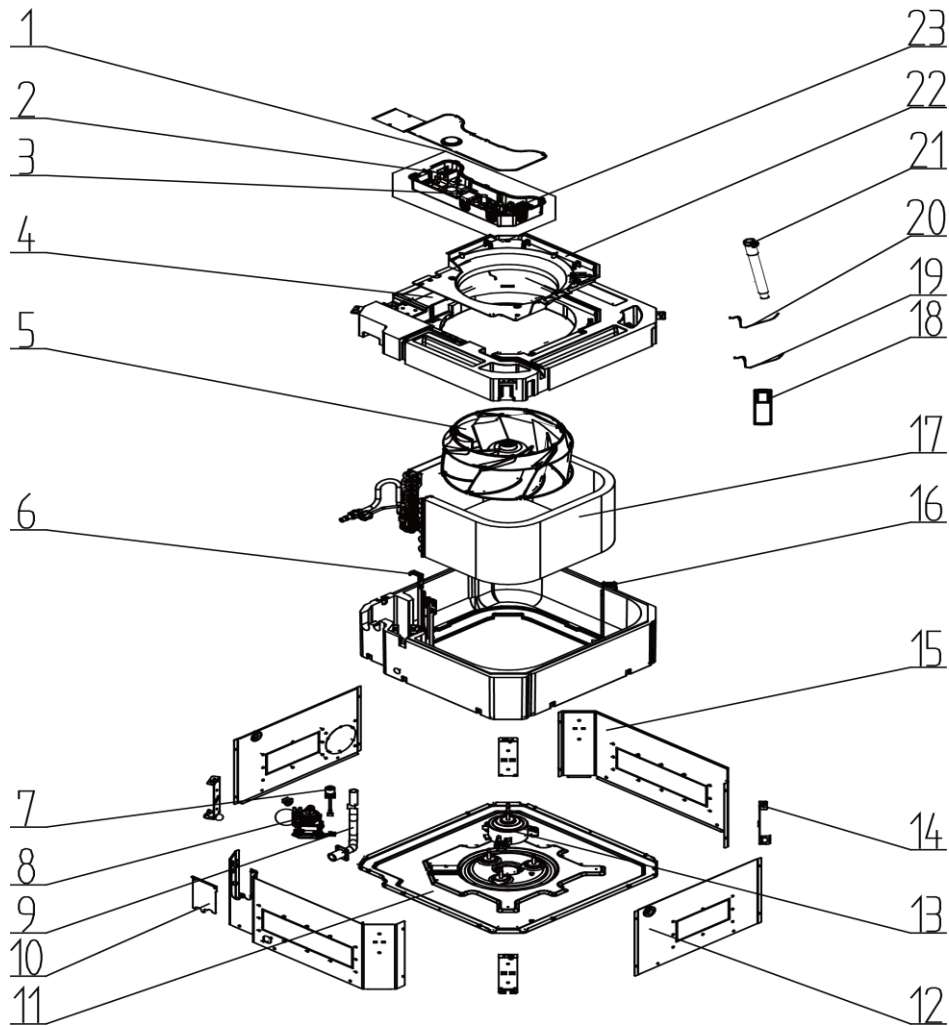

No.	Material name	Finished Product Code	Quantity
1	Electric Box Assy	100002003276	1
2	Terminal Board	42011106	1
3	Main Board	300002060226	1
4	Water Tray Assy	000069060065	1
5	Centifugal Fan	103003060008	1
6	Connection Sheet Sub-Assy	017025060047	1
7	Water Level Switch	43002400000502	1
8	Water Pump	43138000058	1
9	Drain Pipe	200070060005	1
10	Sealplate	012034060119	1
11	Seat Board Sub-Assy	017080060023	1
12	Side Plate	012010060177	1
13	Brushless DC Motor	150104060012	1

No.	Material name	Finished Product Code	Quantity
14	Mounting Rack Sub-Assy	017044060011	4
15	Side Plate	012010060175	1
16	Support	012060061048	1
17	Evaporator Assy	011001060299	1
18	Remote Control	305001060024	1
19	Room Sensor	39000191	1
20	Temperature Sensor	3900005911	1
21	Drain Hose Sub-Assy	05232702	1
22	Flow Guide Loop	200150060003	1
23	Terminal Board	42018000551	1

GUD71T/A-T(Product Code: ET010N1420), **GUD85T/A-T**(Product Code: ET010N1430)

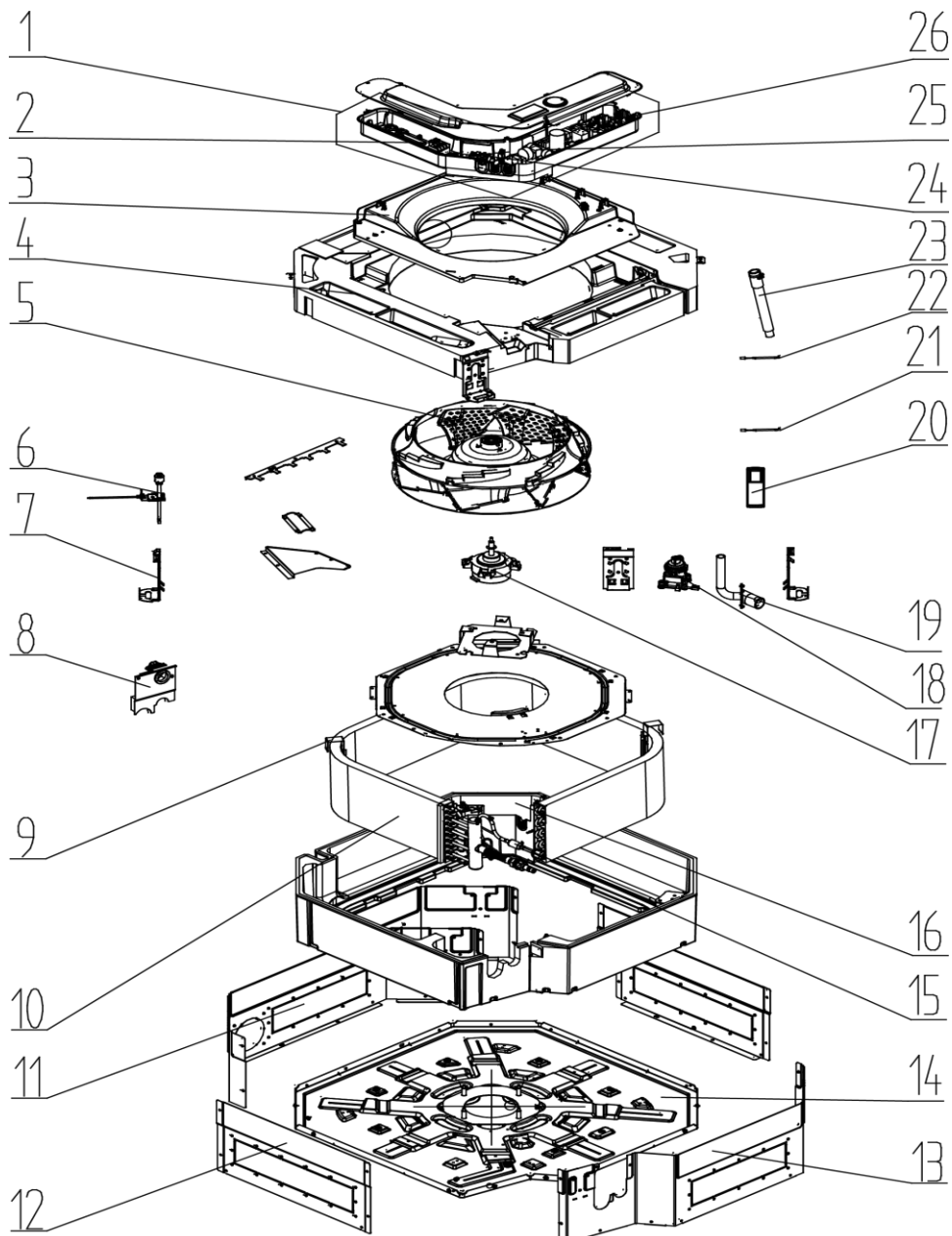

No.	Material name	Finished Product Code	Quantity
1	Electric Box Assay	100002061280	1
2	Terminal Board	42018000551	1
3	Diversion Circle	26909400067	1
4	Water Tray Assay	000069060008	1
5	Centrifugal Fan	10429400004	1
6	Liquid Level Switch	4502021601	1
7	Body Installing Plate	01332701	4
8	Seal Plate Assay	01499400003	1
9	Fixed Mount1	01849400020	3
10	Evaporator Assay	01100100025401	1
11	Side Plate 1	01319400049	1
12	Side Plate 3	01319400051	2
13	Side Plate 2	01319400050	1
14	Seat Board Sub-assay	02229400011	1
15	Strainer	07213050	1
16	Support	01809400052	1
17	Brushless DC Motor	1570410000701	1
18	Water Pump	43138000058	1
19	Drainage Pipe Sub-assay	26909400055	1
20	Remote Controller	305001060024	1
21	Temperature Sensor	390000453	1
22	Temperature Sensor	39000286	1
23	Drain Hose Sub-assay	05232702	1
24	Terminal board	42000100000202	1
25	Filter Board	30221000021	1
26	Main Board	300002060224	1

GUD100T/A-T(Product Code: ET010N1440)

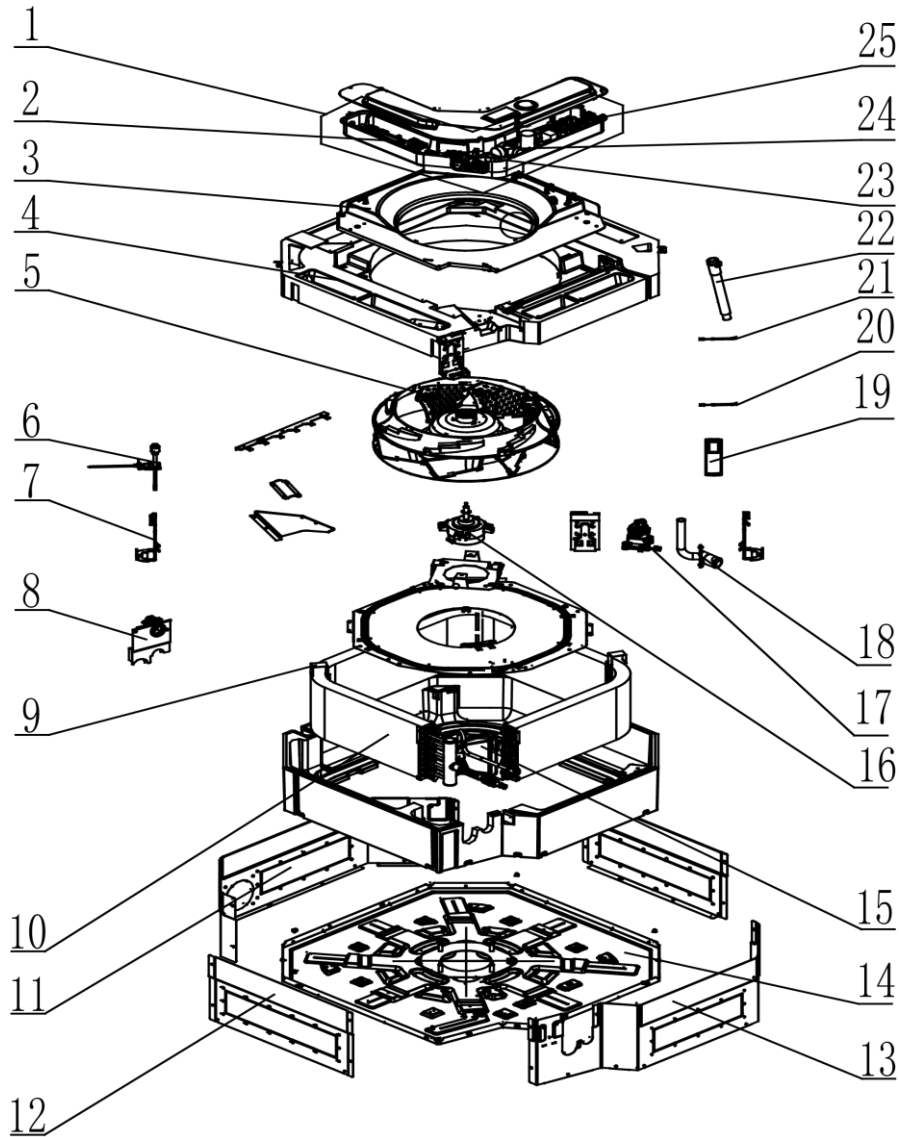

No.	Material name	Finished Product Code	Quantity
1	Electric Box Assay	100002061280	1
2	Terminal Board	42018000551	1
3	Diversion Circle	26909400067	1
4	Water Tray Assay	000069060008	1
5	Centrifugal Fan	10429400004	1
6	Liquid Level Switch	4502021601	1
7	Body Installing Plate	01332701	4
8	Seal Plate Assay	01499400003	1
9	Fixed Mount1	012078060022	3
10	Evaporator Assay	011001060201	1
11	Side Plate 1	01319400049	1
12	Side Plate 3	01319400051	2
13	Side Plate 2	01319400050	1
14	Seat Board Sub-assay	02229400011	1
15	Support	012060060787	1

No.	Material name	Finished Product Code	Quantity
16	Brushless DC Motor	1570410000701	1
17	Water Pump	43138000058	1
18	Drainage Pipe Sub-assay	26909400055	1
19	Remote Controller	305001060024	1
20	Temperature Sensor	390000453	1
21	Temperature Sensor	39000286	1
22	Drain Hose Sub-assay	05232702	1
23	Terminal board	42000100000202	1
24	Filter Board	30221000021	1
25	Main Board	300002060224	1

GUD125T/A-T(Product Code: ET010N1450)

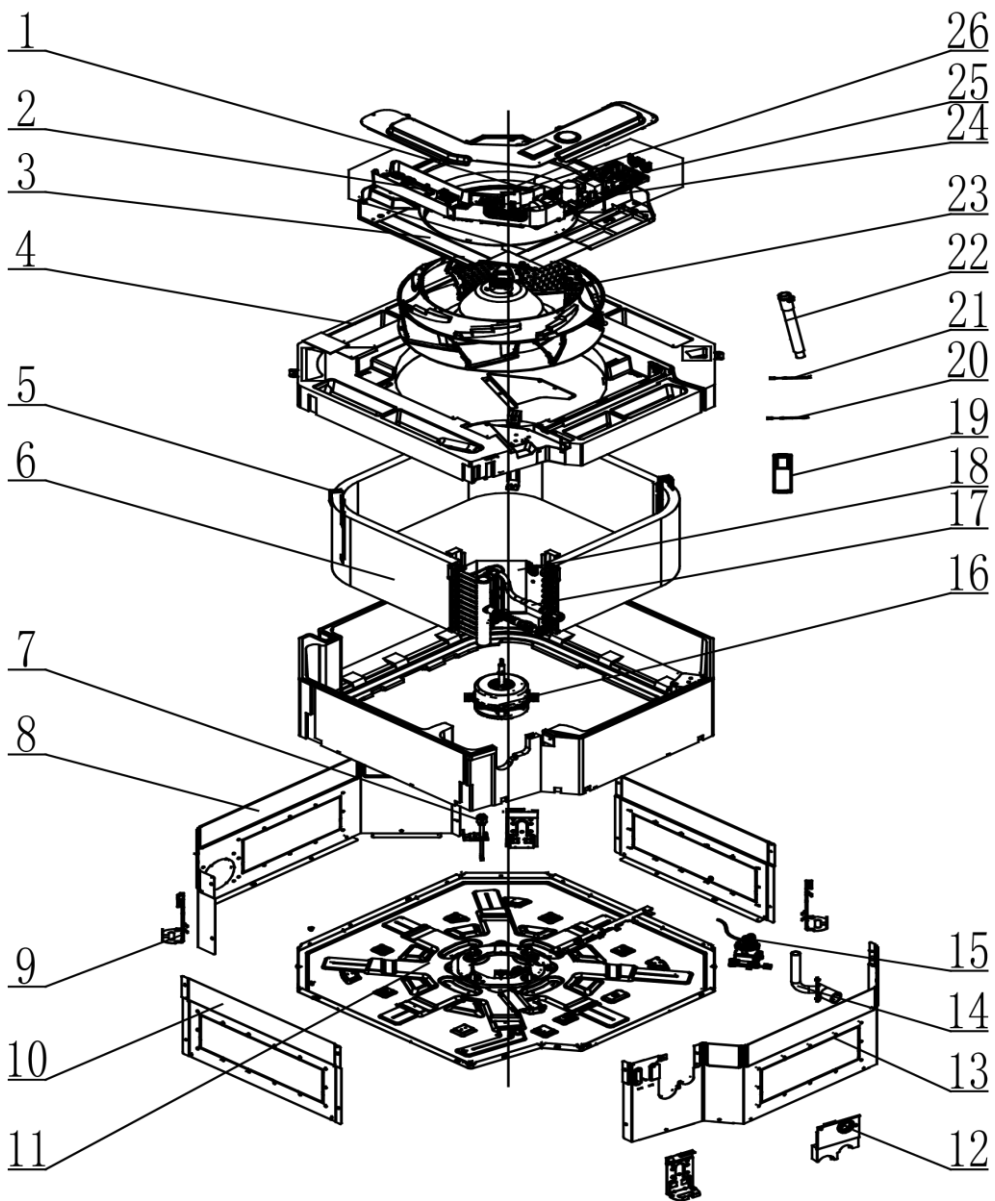

No.	Material name	Finished Product Code	Quantity
1	Electric Box Assay	100002061280	1
2	Terminal Board	42018000551	1
3	Diversion Circle	10479400002	1
4	Water Tray Assay	000069060008	1
5	Fixed Mount1	01849400007	3
6	Evaporator Assay	011001000225	1
7	Liquid Level Switch	4502021601	1
8	Side Plate 1	01319400025	1
9	Body Installing Plate	01332701	4
10	Side Plate 3	01319400036	2
11	Seat Board Sub-assay	02229400011	1
12	Seal Plate Assay	01499400001	1
13	Side Plate 2	01319400026	1
14	Drainage Pipe Sub-assay	26909400055	1
15	Water Pump	43138000058	1
16	Brushless DC Motor	15709400009	1
17	Strainer	07415210	1
18	Connection Sheet Assay	01349400025	1
19	Remote Controller	305001060024	1
20	Temperature Sensor	390000453	1
21	Temperature Sensor	39000286	1
22	Drain Hose Sub-assay	05339400001	1
23	Centrifugal Fan	10429400003	1
24	Filter Board	30221000021	1
25	Main Board	300002060224	1
26	Terminal board	42000100000202	1

GUD140T/A-T(Product Code: ET010N1460)

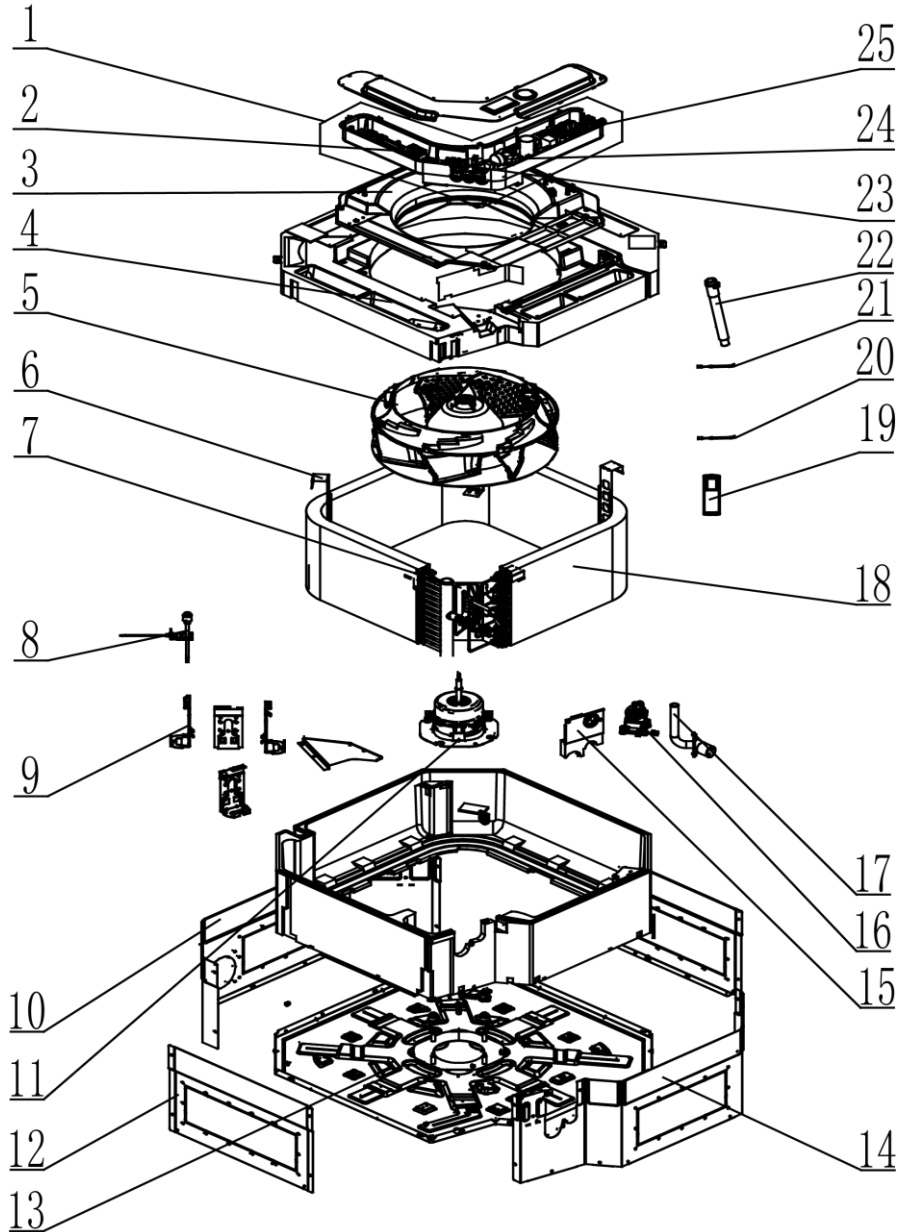

No.	Material name	Finished Product Code	Quantity
1	Electric Box Assy	10002061280	1
2	Terminal Board	42018000551	1
3	Diversion Circle	10479400002	1
4	Water Tray Assy	000069060008	1
5	Centrifugal	10429400003	1
6	Evaporator Support	1849406	3
7	Connection Sheet Assy	01249400012	1
8	Liquid Level Switch	4502021601	1
9	Body Installing Plate	01332701	4
10	Side Plate 1	01319400025	1
11	Brushless DC Motor	15709400009	1
12	Side Plate 3	01319400036	2

No.	Material name	Finished Product Code	Quantity
13	Seat Board Sub-assay	02229400011	1
14	Side Plate 2	01319400026	1
15	Seal Plate Assay	01499400001	1
16	Water Pump	43138000058	1
17	Drainage Pipe Sub-assay	26909400055	1
18	Evaporator Assay	011001060193	1
19	Remote Controller	305001060024	1
20	Temperature Sensor	390000453	1
21	Temperature Sensor	39000286	1
22	Drain Hose Sub-assay	05339400001	1
23	Terminal board	42000100000202	1
24	Filter Board	30221000021	1
25	Main Board	300002060224	1

GUD160T/A-T(Product Code: ET010N1470)

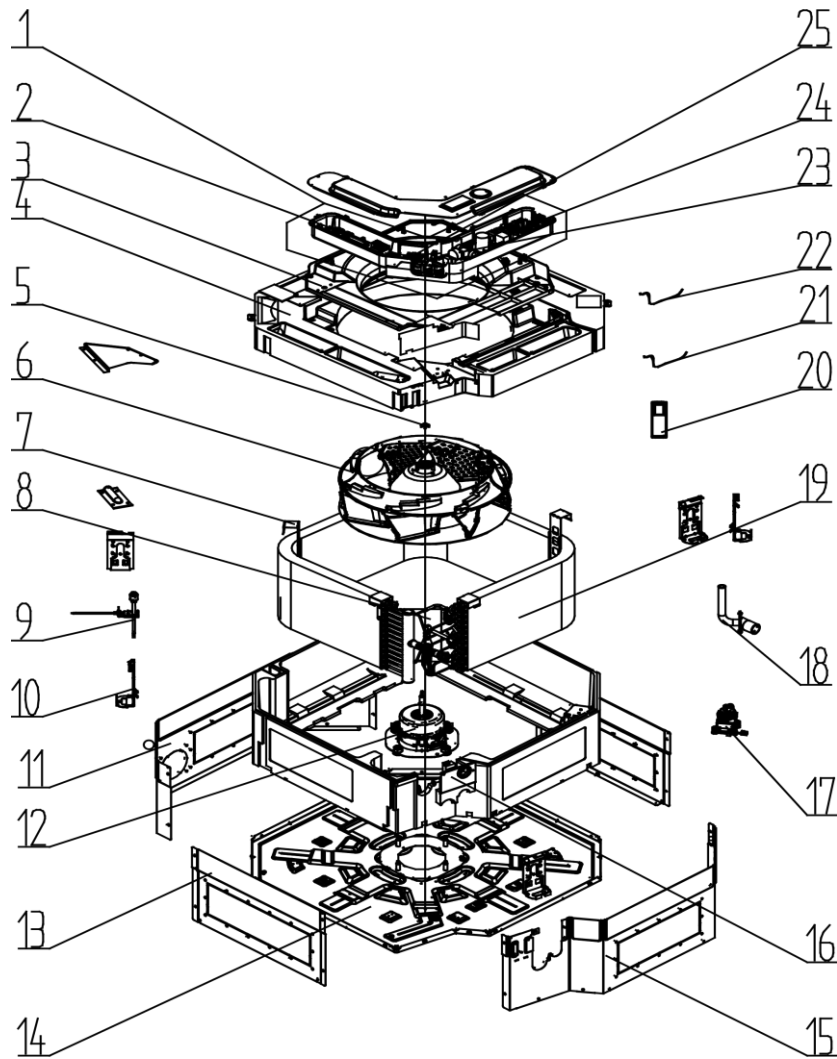

No.	Material name	Finished Product Code	Quantity
1	Electric Box Assay	100002061280	1
2	Terminal Board	4201800002601	1
3	Diversion Circle	10479400002	1
4	Water Tray Assay	01289400026	1
5	Fan Fixer	10312701	1
6	Centrifugal Fan	10429400003	1
7	Evaporator Support	01849406	1
8	Connected Board Assay of Evaporator	01249400012	1
9	Water Level Switch	4502021601	1
10	Body Installing Plate	01332701	1
11	Side Plate 1	01319400025	1
12	Brushless DC Motor	15709400009	1
13	Side Plate 3	01319400036	2
14	Base Plate Assay	02229400021	1
15	Side Plate 2	01319400026	1
16	Seal plate Assay	01499400001	1
17	Water Pump	43138000058	1
18	Drainage Pipe Sub-assay	26909400055	1
19	Evaporator Assay	011001060200	1
20	Remote Controller	305001060024	1
21	Temperature Sensor	39000286	1
22	Temperature Sensor	390000453	1
23	Filter Board	30221000021	1
24	Main Board	300002060224	1
25	Terminal Board	4200010000202	1

GUD35P/A-T(Product Code: CF022N1650)

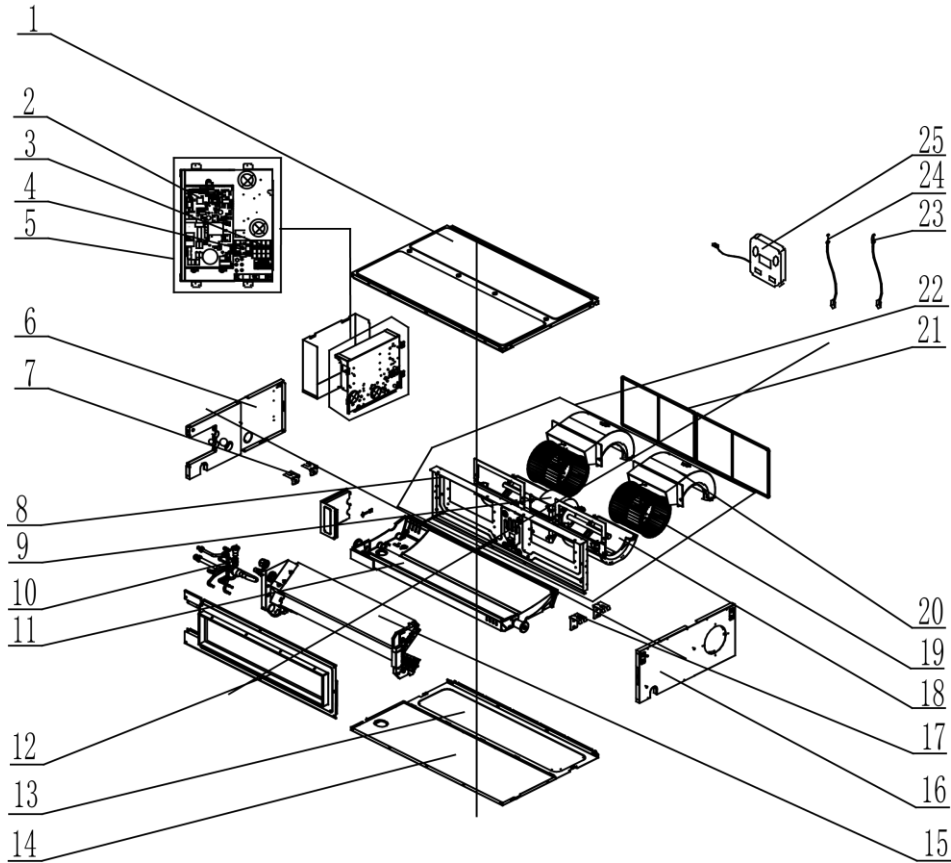

No.	Material name	Finished Product Code	Quantity
1	Top Cover Board Assy	000132000019	1
2	Main Board	300002060223	1
3	Terminal Board	42018000551	1
4	Terminal Board	420111106	1
5	Electric Box Assy	100002002911	1
6	Left Side Plate Assy	01314100076	1
7	Hook 2	01344100034	2
8	Blower Mounting Plate Sub-assy	01325200034	1
9	Brushless DC Motor	1570410000102	1
10	Strainer	0721200102	1
11	Water Tray Assy	01285200020	1
12	Air Outlet Frame Assy	01374100057	1
13	Cover Plate (Air return)	01265200057	1
14	Bottom Cover Plate Assy	01264100102	1
15	Evaporator Assy	011001000473	1
16	Right Side Plate Assy	01315200053	1
17	Hook	02112446	2
18	Propeller Housing (Lower)	26905200019	2
19	Centrifugal Fan	10425200003	2
20	Propeller Housing (Upper)	26905200018	2
21	Filter Sub-assy	111001000082	2

No.	Material name	Finished Product Code	Quantity
22	Centrifugal Fan Assy	15404100031	1
23	Temperature Sensor	390000597	1
24	Ambient Temperature Sensor	39000191	1
25	Display Board	300001000204	1

GUD50P/A-T(Product Code: CF022N1630)

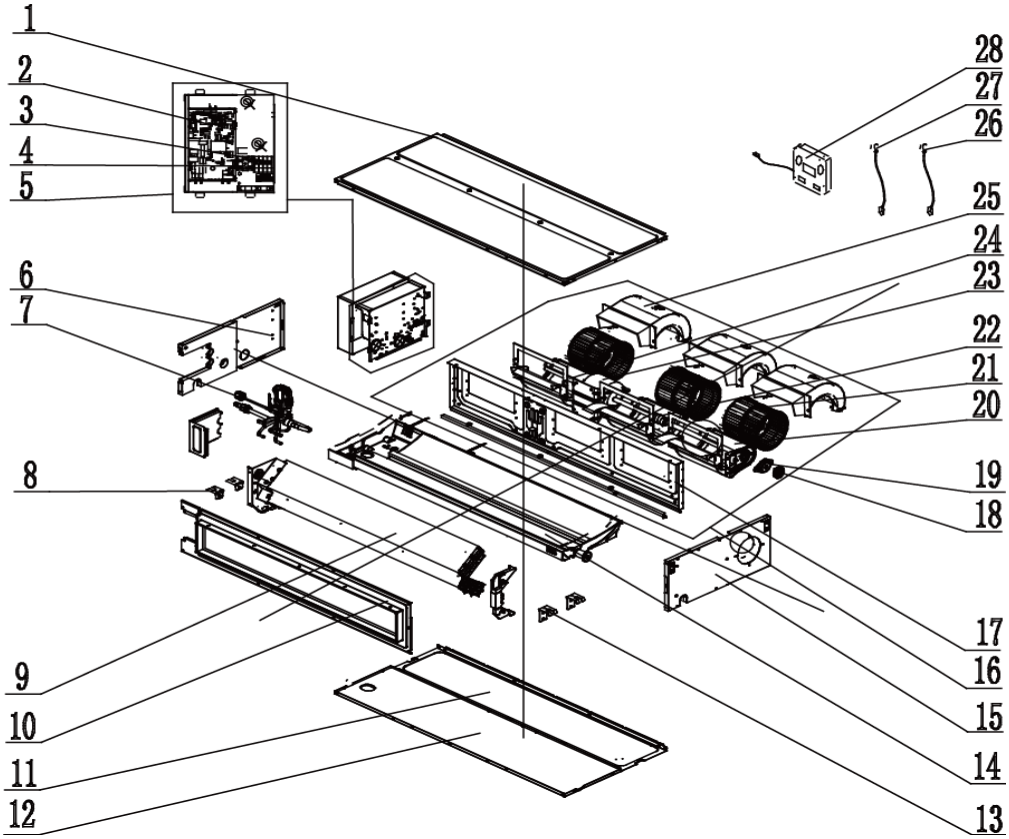

No.	Material name	Finished Product Code	Quantity
1	Top Cover Board Assy	000132000020	1
2	Main Board	300002060223	1
3	Terminal Board	42018000551	1
4	Terminal Board	42011106	1
5	Electric Box Assy	100002002911	1
6	Left Side Plate Assy	01314100076	1
7	Strainer	0721200102	1
8	Hook 2	01344100034	2
9	Evaporator Assy	011001060229	1
10	Air Outlet Frame Assy	01374100058	1
11	Cover Of Air-in	01265200073	1
12	Bottom Cover Plate Assy	01264100103	1
13	Hook	02112446	2
14	Water Tray Assy	01285200022	1
15	Right Side Plate Assy	01315200053	1

No.	Material name	Finished Product Code	Quantity
16	Centrifugal Fan Assy	15404100032	1
17	Blower Mounting Plate Sub-assy	01325200035	1
18	Bearing Holder Sub-assy	26151139	1
19	Support Of Motor Bearing	02285200001	1
20	Propeller Housing (Lower)	26905200019	3
21	Centrifugal Fan	15404100032	1
22	Joint Slack	73018731	1
23	Brushless DC Motor	1570410000102	1
24	Rotary Axis Sub-assy	73018761	1
25	Propeller Housing (Upper)	26905200018	3
26	Temperature Sensor	390000597	1
27	Room Sensor	39000191	1
28	Display Board	300001000204	1

GUD71P/A-T(Product Code: CF022N1620), GUD85P/A-T(Product Code: CF022N1610)

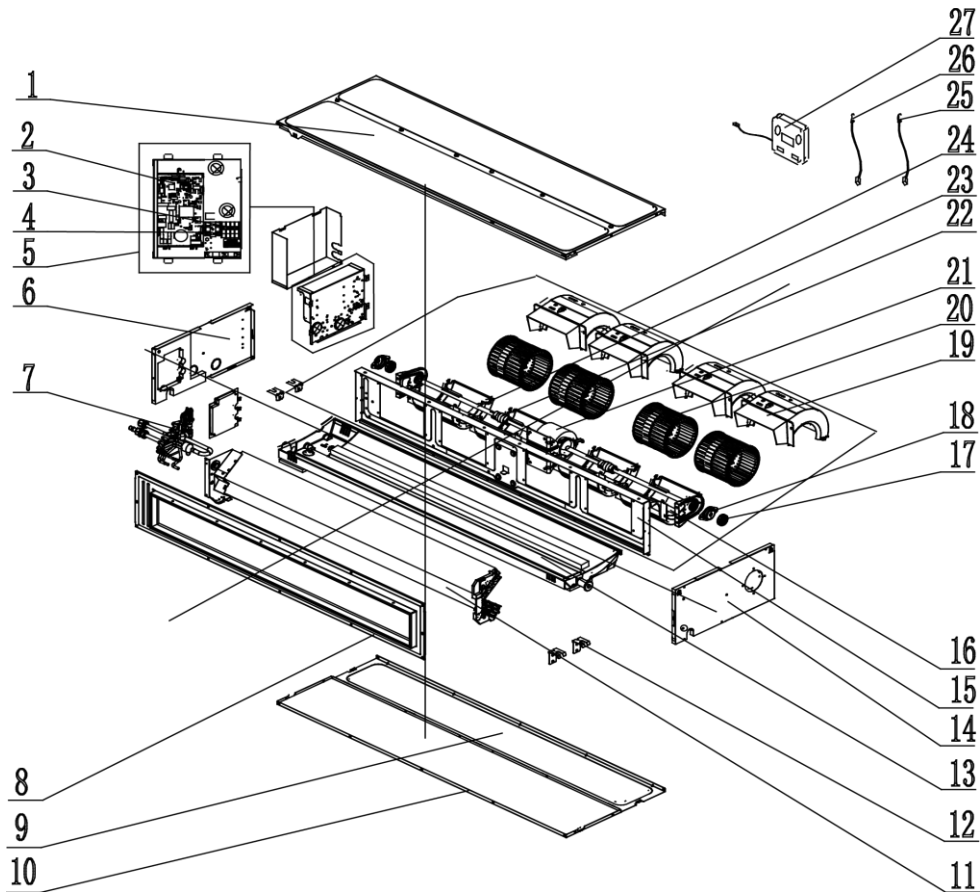

No.	Material name	Finished Product Code	Quantity
1	Top Cover Board Assay	0126520015101	1
2	Main Board	300002060223	1
3	Terminal Board	42018000551	1
4	Terminal Board	42011106	1
5	Electric Box Assay	100002002911	1
6	Left Side Plate Assay	01315200170	1
7	Strainer	0721200102	1
8	Air Outlet Frame Assay	000141000021	1
9	Cover Of Air-in	01265200158	1
10	Bottom Cover Plate Assay	01265200152	1
11	Evaporator Assay	011001060080	1
12	Hook 2	01344100034	4
13	Water Tray Assay	000069000103	1
14	Right Side Plate Assay	01315200169	1
15	Blower Mounting Plate Sub-assay	01325200095	1
16	Propeller Housing (Lower)	26905200123	4
17	Bearing Holder Sub-assay	26151139	1
18	Support Of Motor Bearing	02285200001	1
19	Propeller Housing (Upper)	26905200122	4
20	Centrifugal Fan	000052060004	1
21	Brushless DC Motor	15704100001	1
22	Joint Slack	73018731	2
23	Rotary Axis Sub-assay	73018761	2
24	Centrifugal Fan Assay	000052060004	1
25	Temperature Sensor	390000597	1
26	Ambient Temperature Sensor	39000191	1
27	Display Board	300001000204	1

GUD100PH/A-T(Product Code: CF022N1590)

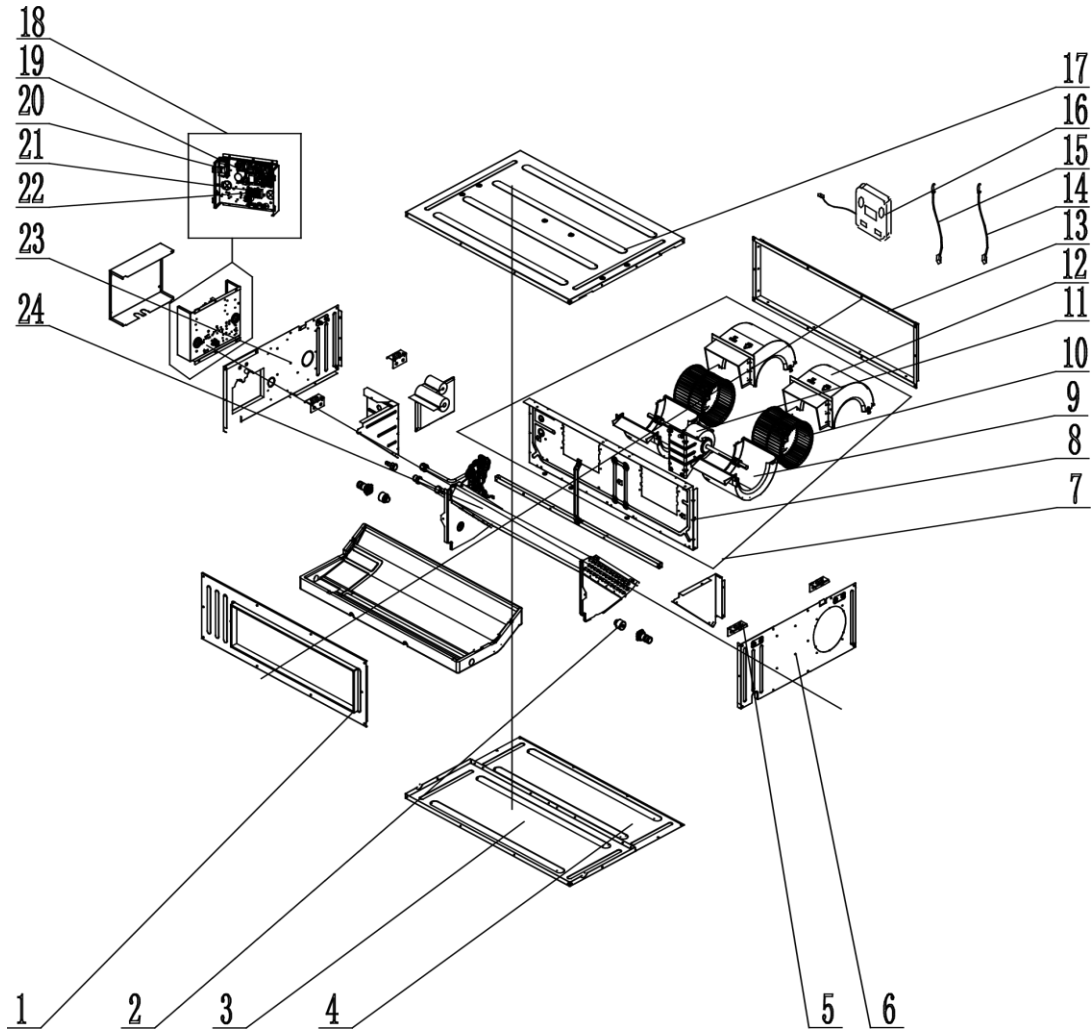

No.	Material name	Finished Product Code	Quantity
1	Air Outlet Frame Assy	01375200026	1
2	Choke Plug of Drain Pipe	76815214	1
3	Bottom Cover Plate	01265200131	1
4	Cover Of Air-in	01265200132	1
5	Hook	02112466	4
6	Right Side Plate Assy	01315200124	1
7	Centrifugal Fan Assy	000052060069	1
8	Blower Mounting Plate Sub-assy	01325200079	1
9	Propeller Housing (Lower)	26905200079	2
10	Centrifugal Fan	000052060069	1
11	Brushless DC Motor	15705200016	1
12	Propeller Housing (Upper)	26905200078	2
13	Air Outlet Frame Assy	01375200026	1
14	Temperature Sensor	390001921	1
15	Ambient Temperature Sensor	3900012123	1
16	Display Board	300001000204	1
17	Top Cover Board Assy	01265200130	1
18	Electric Box Assy	100002061152	1

No.	Material name	Finished Product Code	Quantity
19	Main Board	300002060227	1
20	Filter Board	300020000017	1
21	Terminal Board	42018000551	1
22	Terminal Board	42000100000101	1
23	Left Side Plate Assay	01315200147	1
24	Evaporator Assay	011001060100	1

GUD125PH/A-T(Product Code: CF022N1570),
 GUD140PH/A-T(Product Code: CF022N1550)

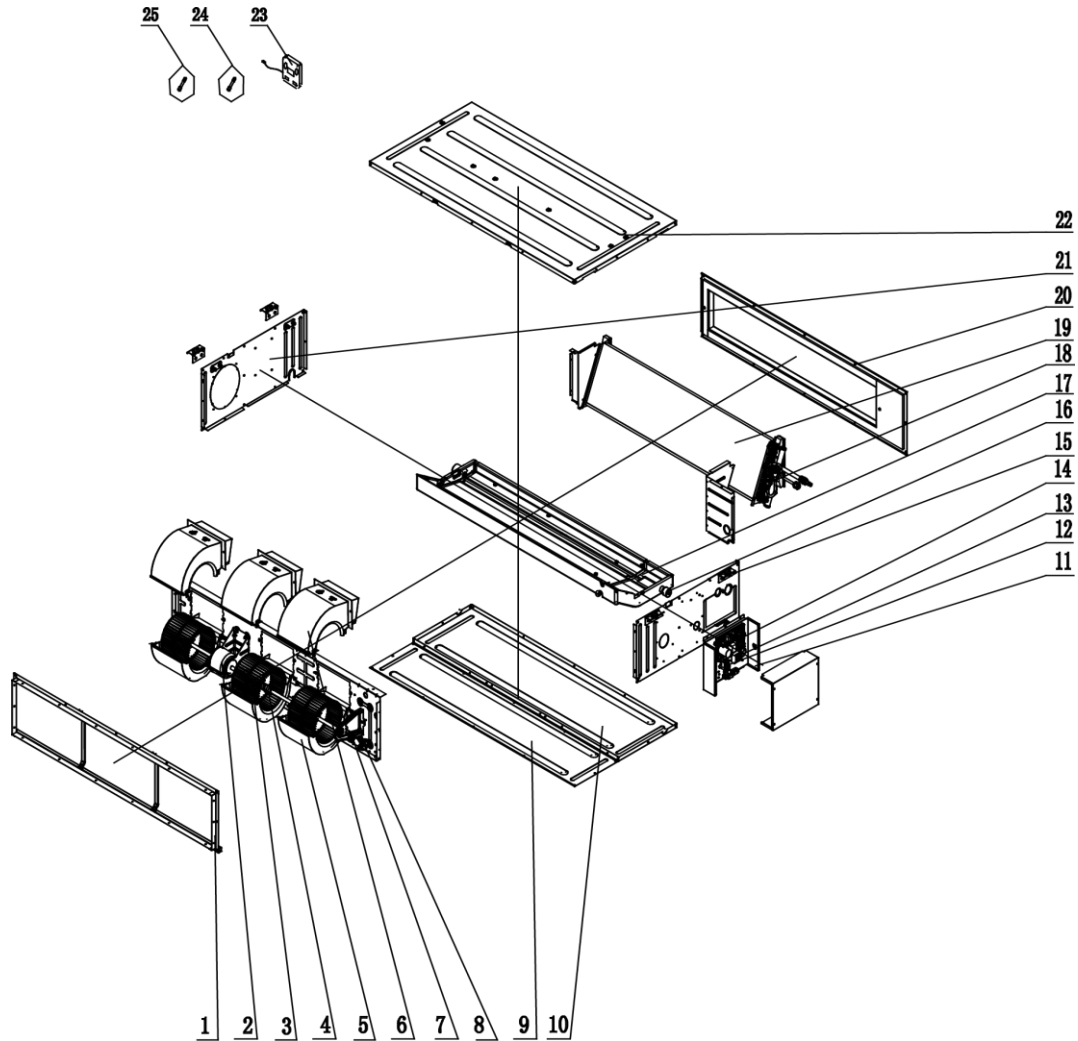

No.	Material name	Finished Product Code	Quantity
1	Return Air Frame Sub-assay	017026000003	1
2	Brushless DC Motor	1570940000603	1
3	Centrifugal Fan	10455200003	3
4	Joint Slack	73018731	1
5	Propeller Housing	26905200079	3
6	Propeller Housing	26905200078	3
7	Bearing Holder Sub-assay	26151139	1
8	Support Of Motor Bearing	02285200001	1
9	Cover Plate(Air return)	01265200123	1

No.	Material name	Finished Product Code	Quantity
10	Bottom Cover Plate	01265200125	1
11	Electric Box Assay	100002061152	1
12	Terminal Board	42000100000101	1
13	Terminal Board	42018000551	1
14	Main Board	300002060227	1
15	Hook	02112466	4
16	Choke Plug of Drain Pipe	76815214	1
17	Foam Sub-assay	12505200021	
18	Strainer	0741520000201	1
19	Evaporator Assay	011001060191	1
20	Air Outlet Frame Assay	01375200023	1
21	Right Side Plate Assay	01315200124	1
22	Top Cover Board Assay	01265200122	1
23	Display Board	300001000204	1
24	Temperature Sensor	390001921	1
25	Ambient Temperature Sensor	3900012123	1

GUD160PH/A-T(Product Code: CF022N1530)

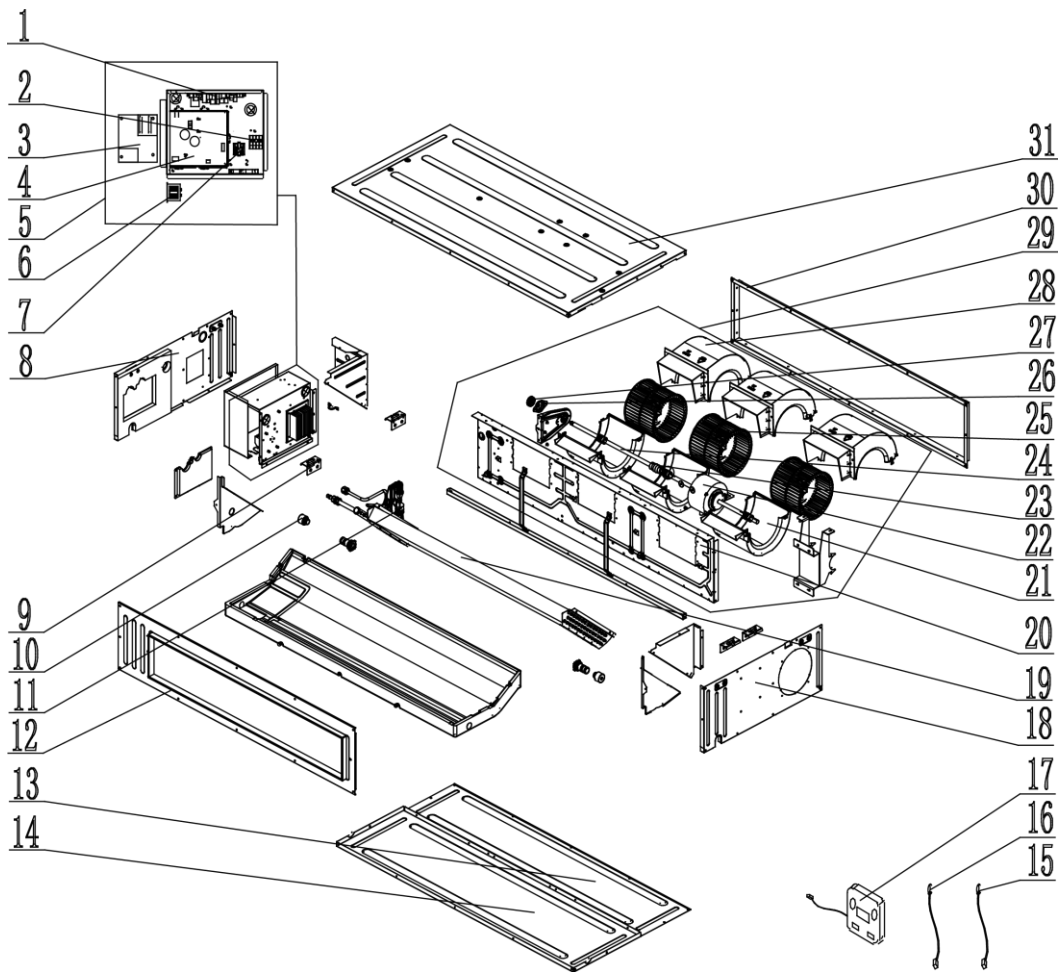

No.	Material name	Finished Product Code	Quantity
1	Main Board	300002060223	1
2	Terminal Board	4201800002601	1
3	Radiator	49018000068	1
4	Main Board	30221000033	1
5	Electric Box Assay	100002061236	1
6	Reactor	43138000047	1
7	Terminal Board	42000100000101	1
8	Left Side Plate Assay	01314100118	1
9	Hook	02112466	4
10	Choke Plug of Drain Pipe	76815214	1
11	Strainer	07415210	1
12	Air Outlet Frame Assay	01375200023	1
13	Cover Plate(Air return)	01265200123	1
14	Bottom Cover Plate	01265200125	1
15	Temperature Sensor	390001921	1
16	Ambient Temperature Sensor	3900012123	1
17	Display Board	300001000204	1
18	Right Side Plate Assay	01315200148	1
19	Evaporator Assay	011001060187	1
20	Blower Mounting Plate Sub-assay	01325200076	1
21	Propeller Housing(Lower)	26905200079	3
22	Brushless DC Motor	1570940000801	1
23	Joint Slack	73018731	1
24	Rotary Axis Sub-assay	73018000117	1
25	Centrifugal Fan	10455200003	3
26	Support Of Motor Bearing	02285200001	1
27	Bearing Holder Sub-assay	26151139	1
28	Propeller Housing(Upper)	26905200078	3
29	Centrifugal Fan Assay	000052000029	1
30	Return Air Frame Sub-assay	01375200029	1
31	Top Cover Board Assay	01264100105	1

GUD35PS/A-T(Product Code: CF022N1640)

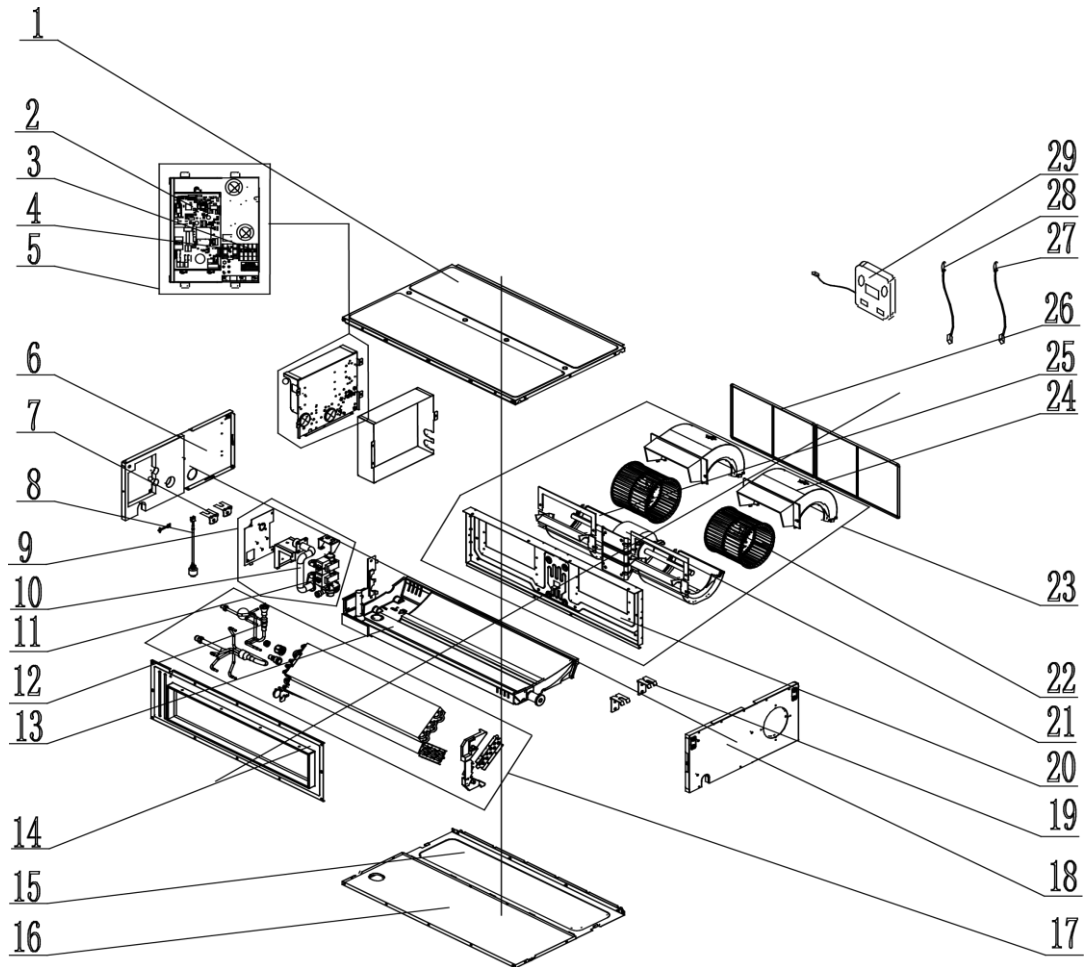

No.	Material name	Finished Product Code	Quantity
1	Top Cover Board Assy	000132000019	1
2	Main Board	300002060223	1
3	Terminal Board	42018000551	1
4	Terminal Board	42011106	1
5	Electric Box Assy	100002002911	1
6	Left Side Plate Assy	000080000022	1
7	Hook 2	01344100034	2
8	Liquid Level Switch	430024000005	1
9	Water Pump Assy	000104060009	1
10	Drainage Pipe (Rubber)	760022000001	1
11	Water Pump	812007060016	1
12	Strainer	0721200102	1
13	Water Tray Assy	012852000020	1
14	Air Outlet Frame Assy	01374100057	1
15	Cover Plate (Air return)	01265200057	1
16	Bottom Cover Plate Assy	01264100102	1
17	Evaporator Assy	011001000473	1
18	Right Side Plate Assy	01315200053	1
19	Hook	02112446	2

No.	Material name	Finished Product Code	Quantity
20	Blower Mounting Plate Sub-assay	01325200034	1
21	Brushless DC Motor	1570410000102	1
22	Centrifugal Fan	10425200003	2
23	Centrifugal Fan Assay	15404100031	1
24	Propeller Housing (Upper)	26905200018	2
25	Propeller Housing (Lower)	26905200019	2
26	Filter Sub-assay	111001000082	2
27	Temperature Sensor	390000597	1
28	Ambient Temperature Sensor	39000191	1
29	Display Board	300001000204	1

GUD50PS/A-T(Product Code: CF022N1620)

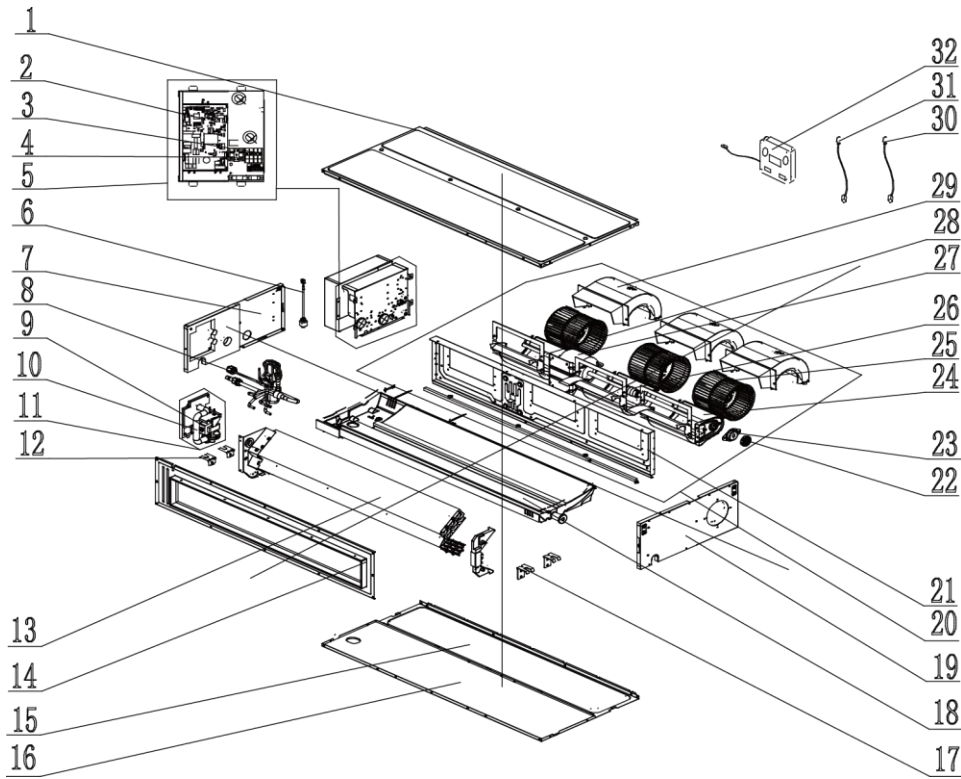

No.	Material name	Finished Product Code	Quantity
1	Top Cover Board Assay	000132000020	1
2	Main Board	300002060223	1
3	Terminal Board	42018000551	1
4	Terminal Board	42011106	1
5	Electric Box Assay	100002002911	1
6	Liquid Level Switch	430024000005	1
7	Left Side Plate Assay	000080000022	1
8	Strainer	0721200102	1
9	Water Pump	812007060016	1
10	Drainage Pipe (Rubber)	760022000001	1
11	Water Pump Assay	000104060009	1

No.	Material name	Finished Product Code	Quantity
12	Hook 2	01344100034	2
13	Evaporator Assay	011001060229	1
14	Air Outlet Frame Assay	01374100058	1
15	Cover Of Air-in	01265200073	1
16	Bottom Cover Plate Assay	01264100103	1
17	Hook	02112446	2
18	Water Tray Assay	01285200022	1
19	Right Side Plate Assay	01315200053	1
20	Centrifugal Fan Assay	15404100032	1
21	Blower Mounting Plate Sub-assay	01325200035	1
22	Bearing Holder Sub-assay	26151139	1
23	Support Of Motor Bearing	02285200001	1
24	Propeller Housing (Lower)	26905200019	3
25	Centrifugal Fan	15404100032	1
26	Joint Slack	73018731	1
27	Brushless DC Motor	1570410000102	1
28	Rotary Axis Sub-assay	73018761	1
29	Propeller Housing (Upper)	26905200018	3
30	Temperature Sensor	390000597	1
31	Room Sensor	39000191	1
32	Display Board	300001000204	1

GUD71PS/A-T(Product Code: CF022N1660),GUD85PS/A-T(Product Code: CF022N1600)

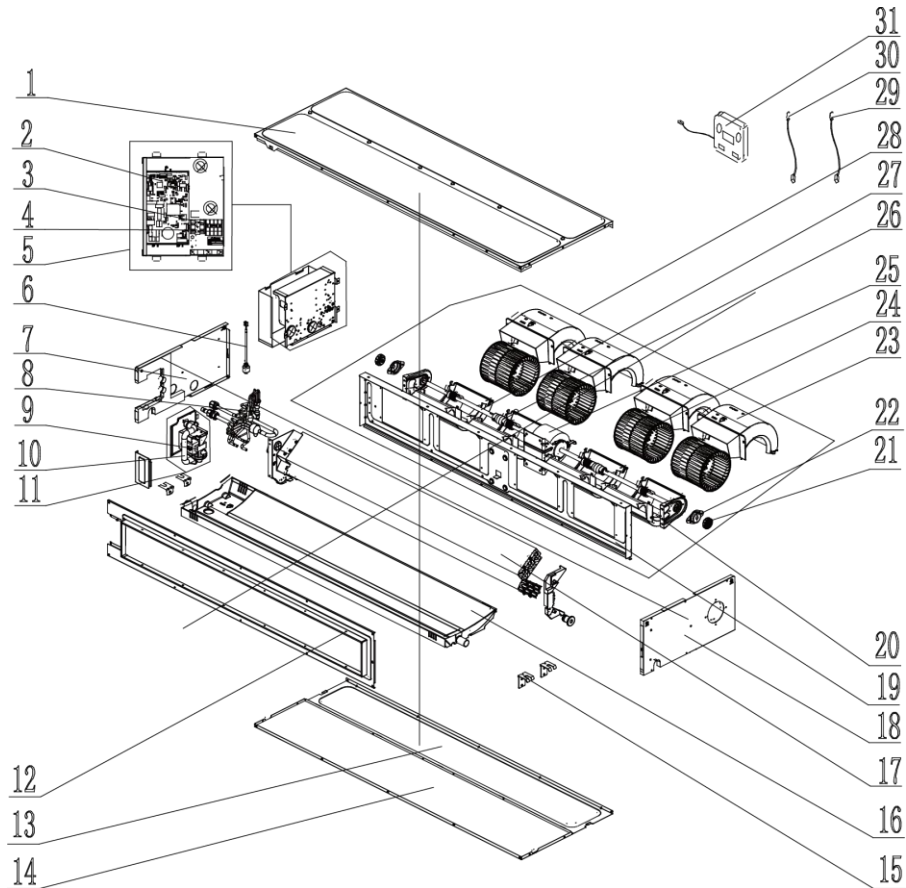

No.	Material name	Finished Product Code	Quantity
1	Top Cover Board Assay	0126520015101	1
2	Main Board	300002060223	1
3	Terminal Board	42018000551	1
4	Terminal Board	42011106	1
5	Electric Box Assay	100002002911	1
6	Liquid Level Switch	430024000005	1
7	Left Side Plate Assay	000080000025	1
8	Strainer	0721200102	1
9	Water Pump	812007060016	1
10	Drainage Pipe (Rubber)	760022000001	1
11	Water Pump Assay	000104060009	1
12	Air Outlet Frame Assay	000141000021	1
13	Cover Of Air-in	01265200158	1
14	Bottom Cover Plate Assay	01265200152	1
15	Hook 2	01344100034	4
16	Water Tray Assay	000069000103	1
17	Evaporator Assay	011001060080	1
18	Right Side Plate Assay	01315200169	1
19	Blower Mounting Plate Sub-assay	01325200095	1
20	Propeller Housing (Lower)	26905200123	4
21	Bearing Holder Sub-assay	26151139	1
22	Support Of Motor Bearing	02285200001	1
23	Propeller Housing (Upper)	26905200122	4
24	Centrifugal Fan	000052060004	1
25	Brushless DC Motor	15704100001	1
26	Joint Slack	7301873173018731	2
27	Rotary Axis Sub-assay	73018761	2
28	Centrifugal Fan Assay	000052060004	1
29	Temperature Sensor	390000597	1
30	Ambient Temperature Sensor	39000191	1
31	Display Board	300001000204	1

GUD100PHS/A-T(Product Code: CF022N1580)

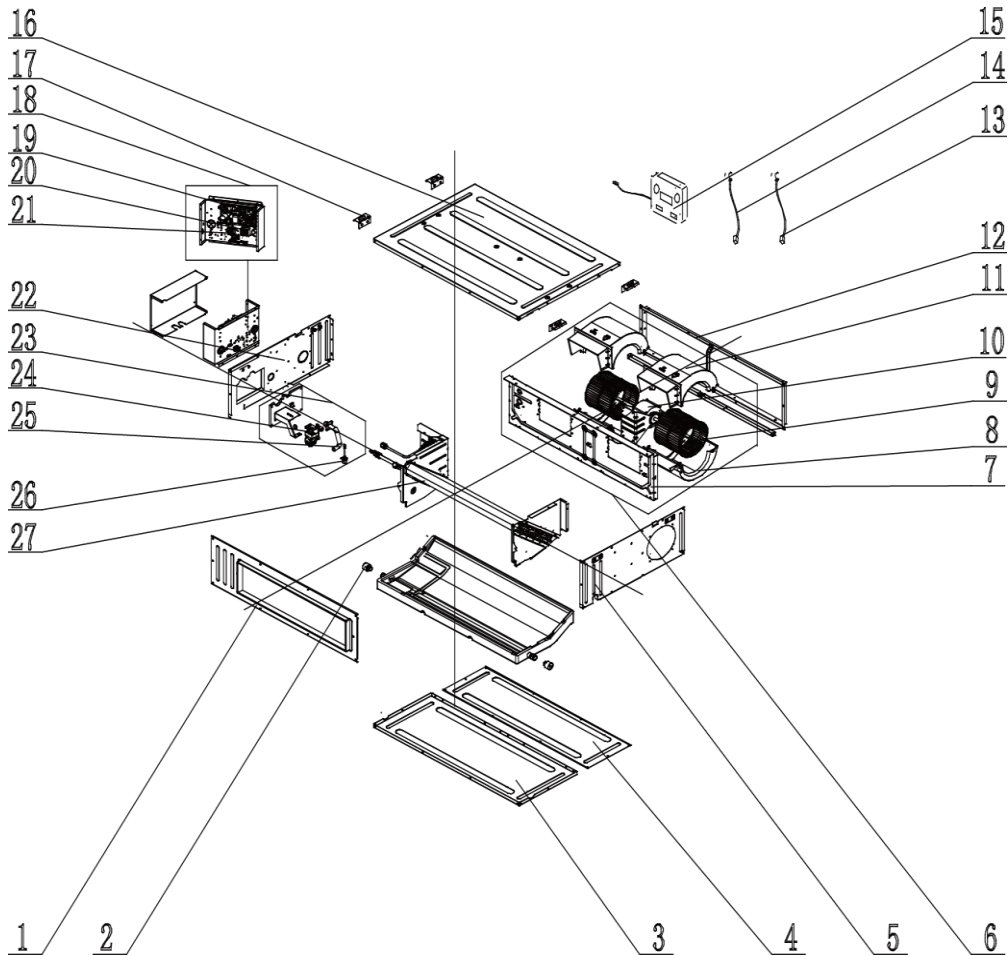

No.	Material name	Finished Product Code	Quantity
1	Air Outlet Frame Assy	01375200026	1
2	Choke Plug of Drain Pipe	76815214	2
3	Bottom Cover Plate	01265200131	1
4	Cover Of Air-in	01265200132	1
5	Right Side Plate Assy	01315200124	1
6	Centrifugal Fan Assy	000052060069	1
7	Blower Mounting Plate Sub-assy	01325200079	1
8	Propeller Housing(Lower)	26905200079	2
9	Centrifugal Fan	000052060069	1
10	Brushless DC Motor	15705200016	1
11	Propeller Housing(Upper)	26905200078	2
12	Return Air Frame Sub-assy	017026000002	1
13	Ambient Temperature Sensor	390001921	1
14	Temperature Sensor	3900012123	1
15	Display Board	300001000204	1
16	Top Cover Board Assy	01265200130	1
17	Hook	02112466	4
18	Electric Box Assy	100002061152	1
19	Main Board	300002060227	1
20	Terminal Board	42018000551	1

No.	Material name	Finished Product Code	Quantity
21	Terminal Board	42000100000101	1
22	Left Side Plate Assay	01315200147	1
23	Water Pump Assay	000104060007	1
24	Water Pump	81200706001601	1
25	Pump Drainpipe	200070060004	1
26	Liquid Level Switch	430024000005	1
27	Evaporator Assay	011001060100	1

GUD125PHS/A-T(Product Code: CF022N1560),

GUD140PHS/A-T(Product Code: CF022N1540)

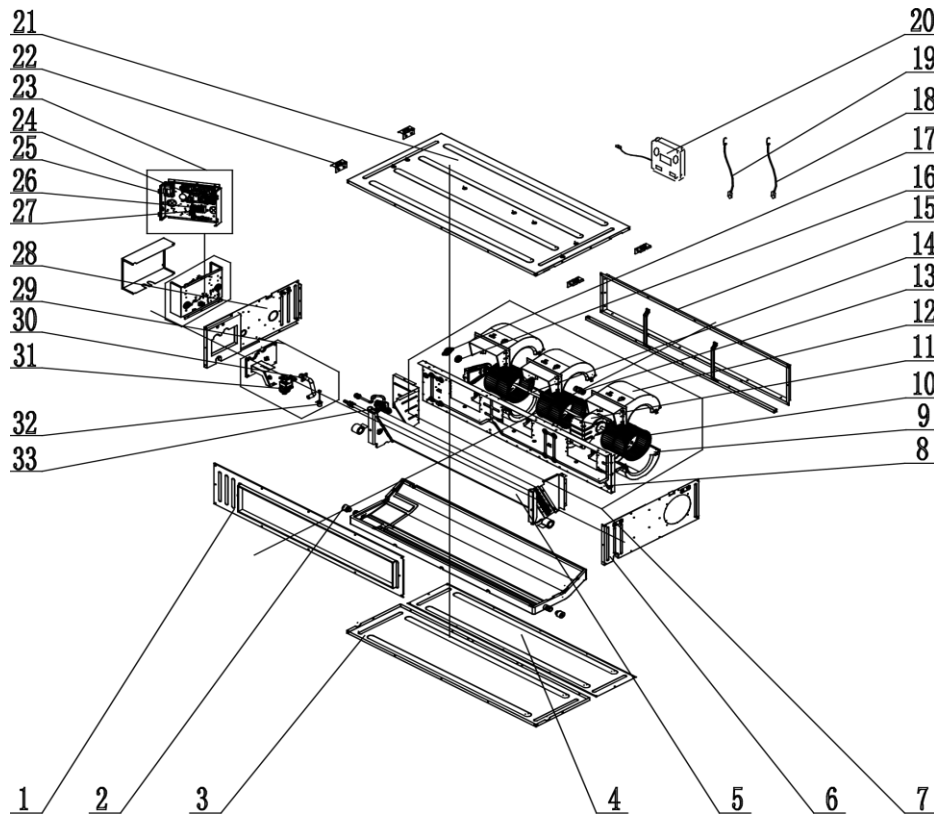

No.	Material name	Finished Product Code	Quantity
1	Air Outlet Frame Assay	01375200023	1
2	Choke Plug of Drain Pipe	76815214	2
3	Bottom Cover Plate	01265200125	1
4	Cover Plate(Air return)	01265200123	1
5	Evaporator Assay	011001060191	1
6	Right Side Plate Assay	01315200124	1
7	Centrifugal Fan Assay	000052060096	1
8	Blower Mounting Plate Sub-assay	01325200076	1
9	Propeller Housing(Lower)	26905200079	3
10	Centrifugal Fan	10455200003	3
11	Brushless DC Motor	1570940000603	1
12	Propeller Housing(Upper)	26905200078	3

No.	Material name	Finished Product Code	Quantity
13	Joint Slack	73018731	1
14	Rotary Axis Sub-assay	73018000117	1
15	Return Air Frame Sub-assay	017026000003	1
16	Bearing Holder Sub-assay	26151139	1
17	Support Of Motor Bearing	02285200001	1
18	Temperature Sensor	390001921	1
19	Ambient Temperature Sensor	3900012123	1
20	Display Board	300001000204	1
21	Top Cover Board Assay	01265200122	1
22	Hook	02112466	4
23	Electric Box Assay	100002061152	1
24	Main Board	300002060227	1
25	Filter Board	300020000017	1
26	Terminal Board	42000100000101	1
27	Terminal Board	42018000551	1
28	Left Side Plate Assay	01315200125	1
29	Water Pump Assay	000104060007	1
30	Pump Drainpipe	200070060004	1
31	Water Pump	81200706001601	1
32	Liquid Level Switch	430024000005	1
33	Strainer	0741520000201	1

GUD160PHS/A-T(Product Code: CF022N1520)

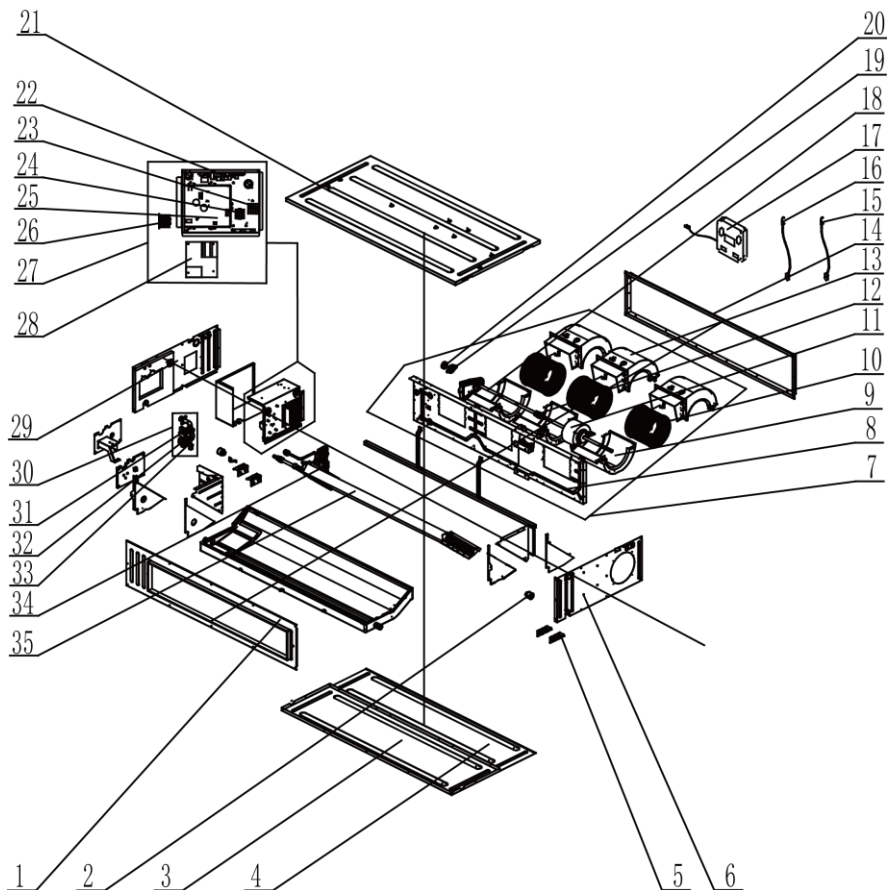

No.	Material name	Finished Product Code	Quantity
1	Air Outlet Frame Assay	01375200023	1
2	Choke Plug of Drain Pipe	76815214	2
3	Bottom Cover Plate	01265200125	1
4	Cover Plate(Air return)	01265200123	1
5	Hook	02112466	4
6	Right Side Plate Assay	01315200148	1
7	Centrifugal Fan Assay	000052000029	1
8	Blower Mounting Plate Sub-assay	01325200076	1
9	Propeller Housing(Lower)	26905200079	3
10	Centrifugal Fan	10455200003	3
11	Brushless DC Motor	1570940000801	1
12	Joint Slack	73018731	1
13	Propeller Housing(Upper)	26905200078	3
14	Return Air Frame Sub-assay	01375200029	1
15	Temperature Sensor	390001921	1
16	Ambient Temperature Sensor	3900012123	1
17	Display Board	300001000204	1
18	Rotary Axis Sub-assay	73018000117	1
19	Support Of Motor Bearing	02285200001	1
20	Bearing Holder Sub-assay	26151139	1
21	Top Cover Board Assay	01264100105	1
22	Main Board	300002060223	1
23	Terminal Board	4201800002601	1
24	Terminal Board	42000100000101	1
25	Main Board	30221000033	1
26	Reactor	43138000047	1
27	Electric Box Assay	100002061236	1
28	Radiator	49018000068	1
29	Left Side Plate Assay	01314100118	1
30	Water Pump Assay	000104060001	1
31	Pump Drainpipe	200070060004	1
32	Water Pump	4313822001	1
33	Liquid Level Switch	430024000005	1
34	Strainer	07415210	1
35	Evaporator Assay	011001060187	1

GUD35ZD/A-T(Product Code: ED020N1720)

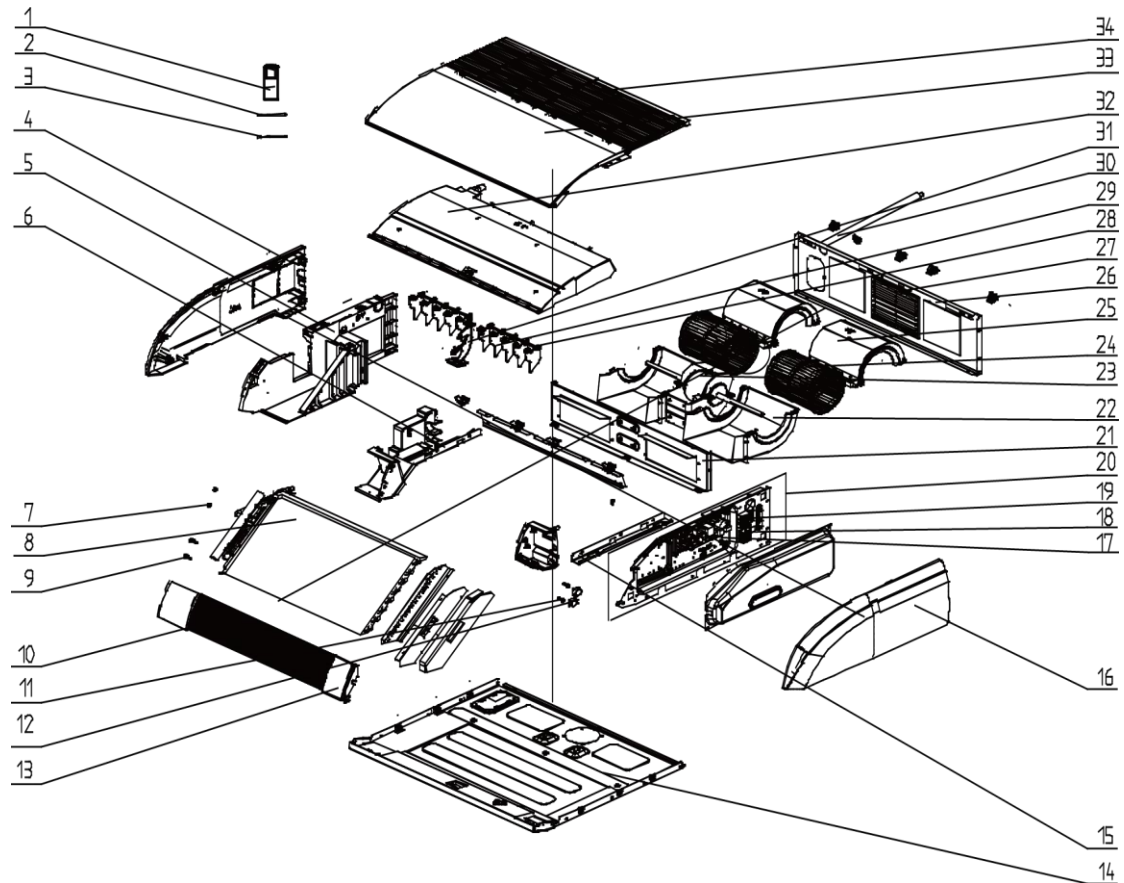

No.	Material name	Finished Product Code	Quantity
1	Remote Controller	305001060024	1
2	Ambient Temperature Sensor	3900012123	1
3	Temperature Sensor	390001923	1
4	Right Cover Plate	26909400071	1
5	Right Side Plate	26909400074	1
6	Installation Supporting Frame(right)	01809402	1
7	Axial Bush	10542704	2
8	Evaporator Assy	011001060235	1
9	Rotating Shaft 3	26909430	2
10	Guide Louver	200004000046	2
11	Crankshaft	200023000001	2
12	Stepping Motor	1521240215	2
13	Display Board	302940000009	1
14	Base Plate Assy	011007000032	1
15	Installation Supporting Frame(Left)	01809401	1
16	Left Cover Plate	26909400070	1
17	Main Board	300002060226	1
18	Terminal Board	42018000551	1
19	Terminal Board	42000100000202	1
20	Electric Box Assy	100002003030	1
21	Clapboard Sub-assy	017021000088	1

No.	Material name	Finished Product Code	Quantity
22	Propeller Housing(Lower)	200230000001	2
23	Brushless DC Motor	15706000037	1
24	Centrifugal Fan	103003000001	2
25	Propeller Housing(Upper)	200230000002	2
26	Rear Side Plate Sub-assay	017051000046	1
27	Filter Sub-assay	111001000001	1
28	Swing Lever	10582009	2
29	Air Louver	200007000001	10
30	Drainage Pipe Sub-assay	05235434	1
31	Supporter(Guide Louver)	26909400076	1
32	Water Tray	200063000024	1
33	Top Cover	012148000046	1
34	Front Grill Sub-assay	200226000004	2

GUD50ZD/A-T(Product Code: ED020N1730)

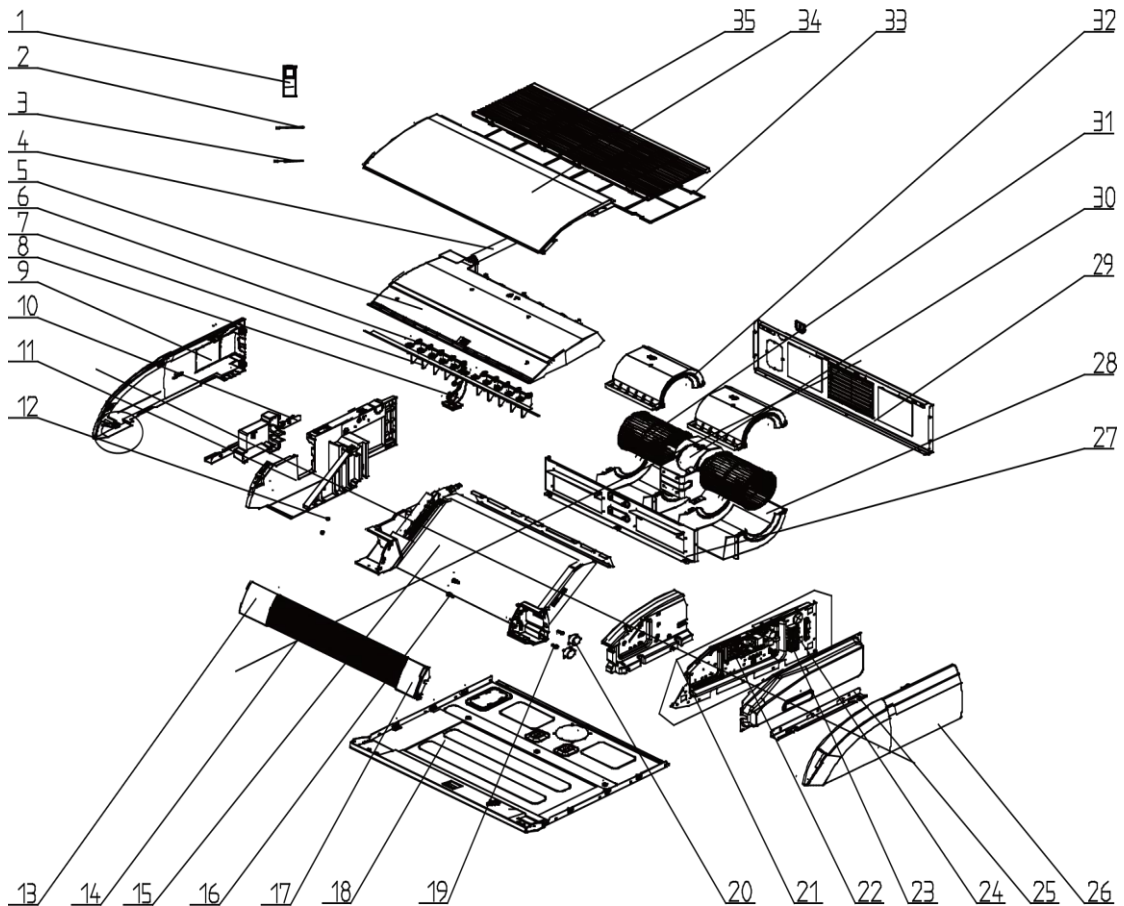

No.	Material name	Finished Product Code	Quantity
1	Remote Controller	305001060024	1
2	Temperature Sensor	390001923	1
3	Ambient Temperature Sensor	3900012123	1
4	Drainage Pipe Sub-assay	05235434	1
5	Water Tray	200063000024	1

No.	Material name	Finished Product Code	Quantity
6	Swing Lever	10582009	2
7	Air Louver	200007000001	10
8	Supporter(Guide Louver)	26909400076	1
9	Right Cover Plate	26909400071	1
10	Installation Supporting Frame(Right)	01809402	1
11	Right Side Plate	26909400074	1
12	Axial Bush	10542704	2
13	Front Panel	200003000001	1
14	Guide Louver	200004000046	2
15	Evaporator Assay	011001000487	1
16	Rotating Shaft 3	26909430	2
17	Display Board	30294000009	1
18	Base Plate Assay	011007000032	1
19	Crankshaft	200023000001	2
20	Stepping Motor	1521240215	2
21	Electric Box Assay	100002003030	1
22	Main Board	300002060226	1
23	Terminal Board	42018000551	1
24	Terminal Board	42000100000202	1
25	Installation Supporting Frame(Left)	01809401	1
26	Left Cover Plate	26909400070	1
27	Clapboard Sub-assay	017021000088	1
28	Propeller Housing(Lower)	200230000001	2
29	Rear Side Plate Sub-assay	017051000046	1
30	Brushless DC Motor	15706000037	1
31	Centrifugal Fan	103003000001	2
32	Propeller Housing(Upper)	200230000002	2
33	Filter Sub-assay	111001000001	1
34	Top Cover	012148000046	1
35	Front Grill	200226000004	2

GUD71ZD/A-T(Product Code: ED020N1740), GUD85ZD/A-T(Product Code: ED020N1750)

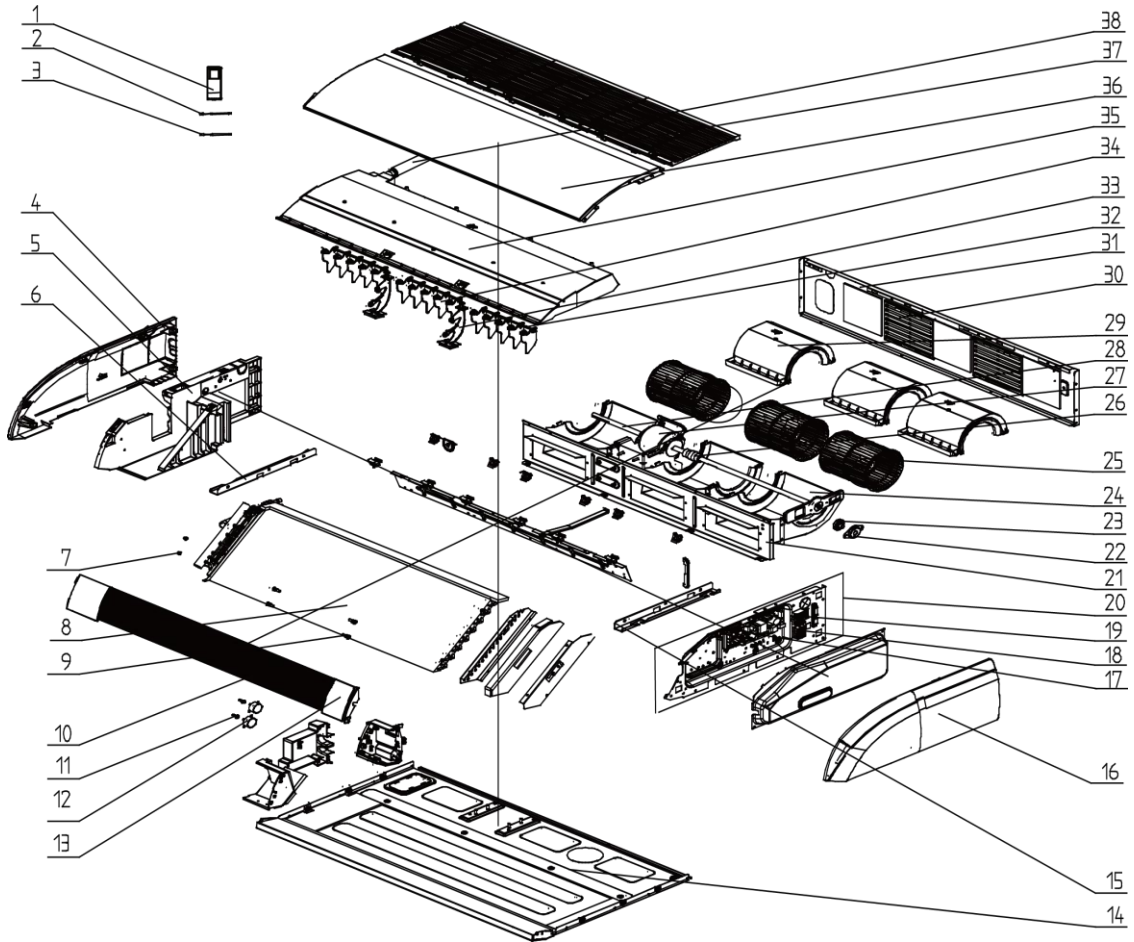

No.	Material name	Finished Product Code	Remarks
1	Remote Controller	305001060024	1
2	Ambient Temperature Sensor	3900012123	1
3	Temperature Sensor	390001923	1
4	Right Cover Plate	26909400071	1
5	Right Side Plate	26909400074	1
6	Installation Supporting Frame(right)	01809402	1
7	Axial Bush	10542704	2
8	Evaporator Assy	011001000202	1
9	Rotating Shaft 3	26909430	4
10	Guide Louver	200004500422	2
11	Crankshaft	200023000001	2
12	Stepping Motor	1521240215	2
13	Display Board	30294000009	1
14	Base Plate Assy	011007000038	1
15	Installation Supporting Frame(Left)	01809401	1
16	Left Cover Plate	26909400070	1
17	Main Board	300002060226	1
18	Terminal Board	42018000551	1
19	Terminal board	42018000551	1

No.	Material name	Finished Product Code	Remarks
20	Electric Box Assay	100002003030	1
21	Clapboard Sub-Assay	01249400018	1
22	Support Of Motor Bearing	01792408	1
23	O-Gasket of Bearing	76512404	1
24	Propeller Housing(Lower)	200230000001	3
25	Centrifugal Fan	103003000001	3
26	Joint Slack	73018731	1
27	Brushless DC Motor	1570520000501	1
28	Roller Wheel	700004500433	1
29	Propeller Housing(Upper)	200230000002	3
30	Filter Sub-Assay	111001000001	2
31	Rear Side Plate Sub-Assay	017051000005	1
32	Swing Lever	10582009	3
33	Supporter(Guide Louver)	26909400076	2
34	Air Louver	200007000001	15
35	Water Tray	200063000003	1
36	Top Cover	01269400012	1
37	Front Grill	26909400072	1
38	Drainage Pipe Sub-Assay	05235434	1

GUD100ZD/A-T(Product Code: ED020N1680)

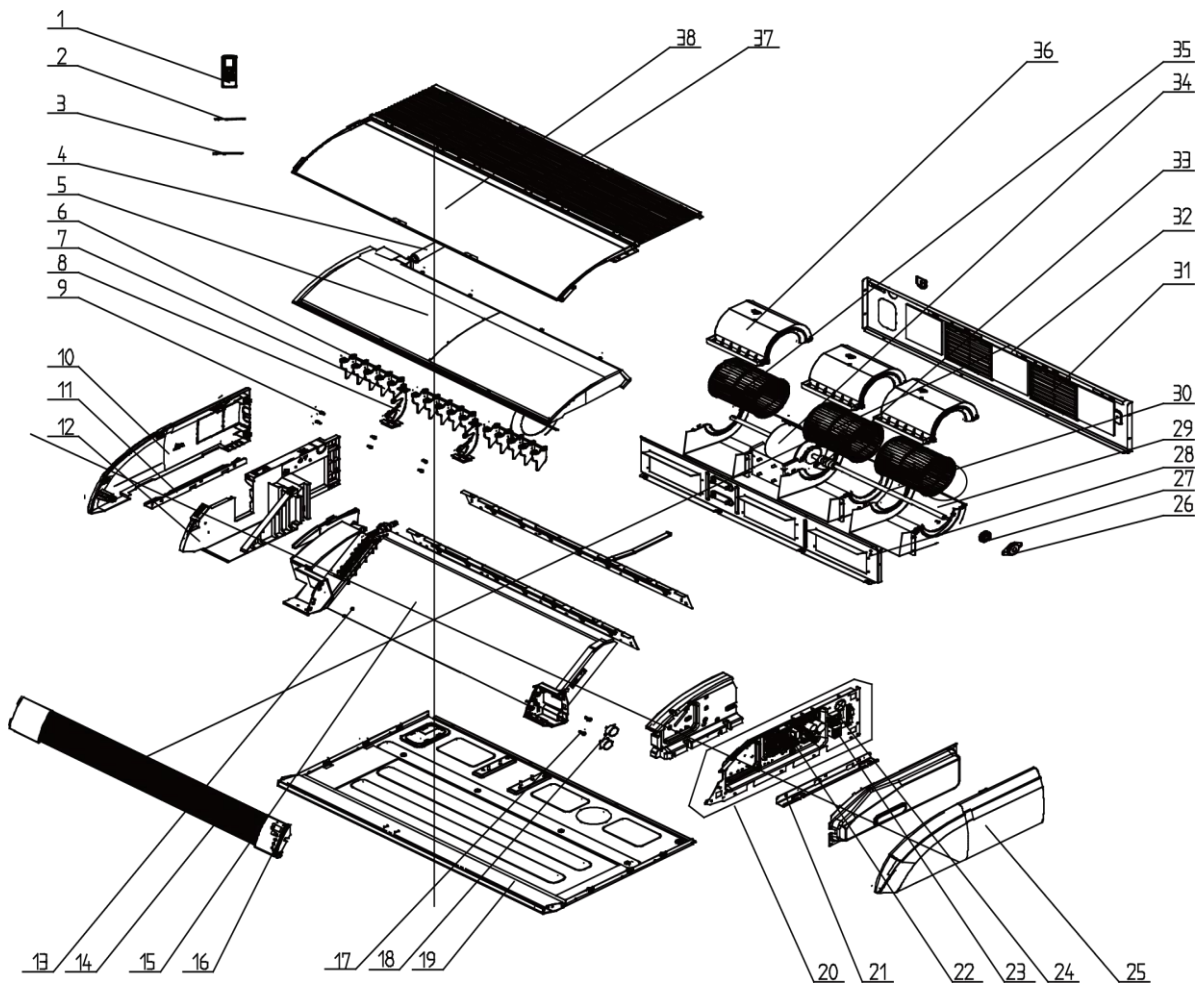

No.	Material name	Finished Product Code	Quantity
1	Remote Controller	305001060024	1
2	Temperature Sensor	390001921	1
3	Ambient Temperature Sensor	3900012123	1
4	Drainage Pipe Sub-Assay	05235434	1
5	Water Tray	200063000003	1
6	Swing Lever	10582009	3
7	Air Louver	200007000001	15
8	Supporter	26909400076	2
9	Rotating Shaft 3	26909430	4
10	Right Cover Plate	26909400071	1
11	Installation Supporting Frame(Right)	01809402	1
12	Right Side Plate	26909400074	1
13	Axial Bush	10542704	2
14	Guide Louver	200004500422	2
15	Evaporator Assay	011001000136	1
16	Display Board	30294000009	1
17	Crankshaft	200023000001	2
18	Stepping Motor	1521240206	2
19	Base Plate Assay	011007000038	1
20	Electric Box Assay	100002003030	1
21	Installation Supporting Frame(Left)	01809401	1
22	Main Board	300002060226	1
23	Terminal Board	42018000551	1
24	Terminal Board	42000100000202	1
25	Left Cover Plate	26909400070	1
26	Support Of Motor Bearing	01792408	1
27	O-Gasket of Bearing	76512404	1
28	Clapboard Assay	000075000040	1
29	Propeller Housing(Lower)	200230000001	3
30	Rotary Axis	700004500433	1
31	Filter Sub-Assay(Rear Side Plate)	111001000001	2
32	Rear Side Plate Sub-Assay	017051000005	1
33	Joint Slack	73018731	1
34	Fan Motor	1570520000501	1
35	Centrifugal Fan	103003000001	3
36	Propeller Housing(Upper)	200230000002	3
37	Front Grill Sub-Assay	26909400066	3
38	Top Cover	01269400012	1

GUD125ZD/A-T(Product Code: ED020N1690)

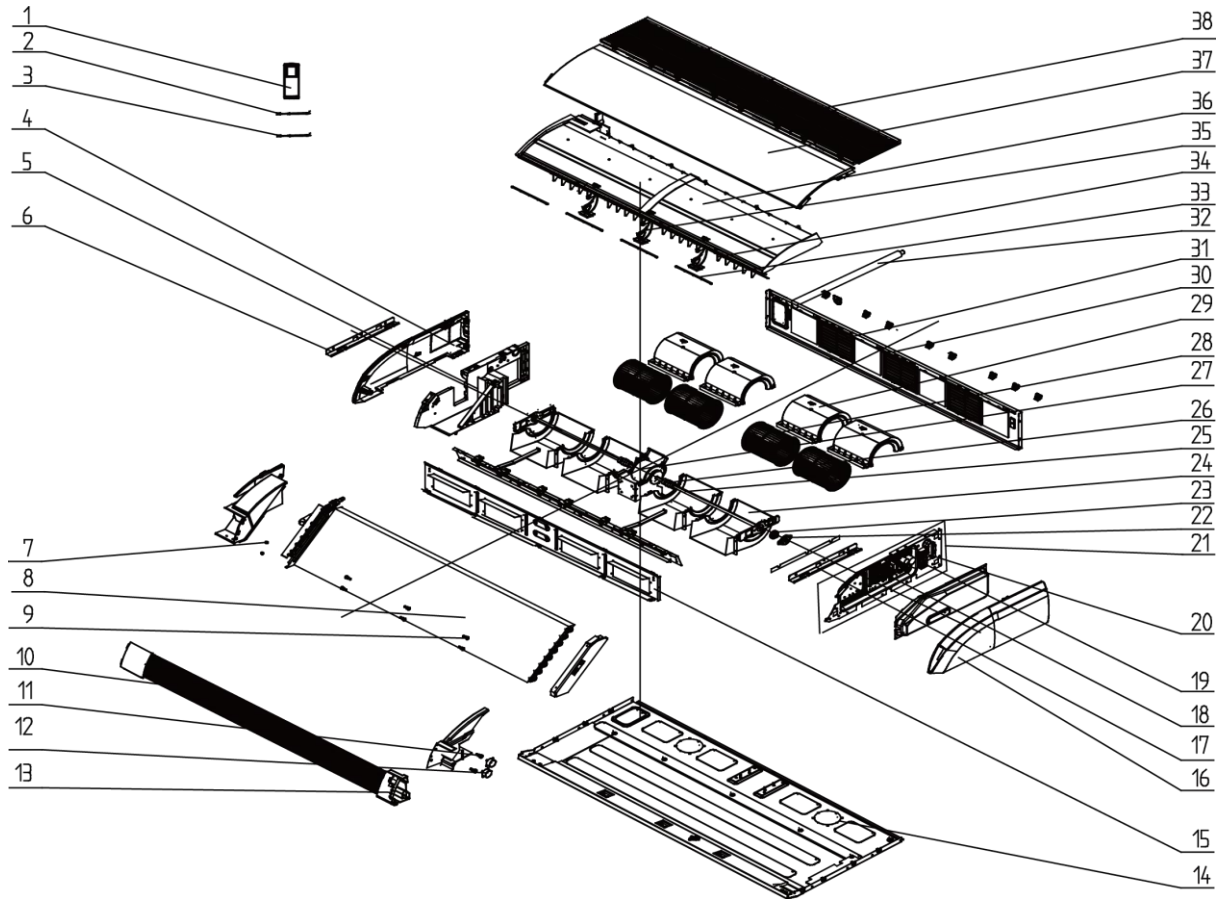

No.	Material name	Finished Product Code	Quantity
1	Remote Controller	305001060024	1
2	Ambient Temperature Sensor	3900012123	1
3	Tube Sensor	3900020720G	1
4	Right Cover Plate	26909400071	11
5	Right Side Plate	26909400074	1
6	Installation Supporting Frame(right)	01809402	1
7	Axial Bush	10542704	2
8	Evaporator Assay	011001060178	1
9	Rotating Shaft 3	26909430	6
10	Guide Louver	200004500426	2
11	Crankshaft	200023000001	2
12	Stepping Motor	1521240206	2
13	Display Board	30294000009	1
14	Base Plate Assay	011007060032	1
15	Clapboard Sub-Assay	01249400019	1
16	Left Cover Plate	26909400070	1
17	Installation Supporting Frame(Left)	01809401	1
18	Main Board	300002060226	1
19	Terminal Board	42018000551	1
20	Terminal Board	4200010000202	1

No.	Material name	Finished Product Code	Quantity
21	Electric Box Assay	100002003030	1
22	Support Of Motor Bearing	01792408	2
23	O-Gasket of Bearing	76512404	1
24	Propeller Housing(Lower)	200230000001	4
25	Roller Wheel	700004000001	2
26	Joint Slack	73018731	2
27	Brushless DC Motor	15709400005	1
28	Centrifugal Fan	103003000001	4
29	Propeller Housing(Upper)	200230000002	4
30	Rear Side Plate Sub-Assay	017051000006	1
31	Filter Sub-Assay	111001000001	3
32	Drainage Pipe Sub-Assay	05235434	1
33	Swing Lever	10582009	4
34	Air Louver	200007000001	20
35	Supporter(Guide Louver)	26909400076	3
36	Water Tray	200063000002	1
37	Top Cover	01269400013P	1
38	Front Grill Sub-assay	26909400066	4

GUD140ZD/A-T(Product Code: ED020N1700),
 GUD160ZD/A-T(Product Code: ED020N1710)

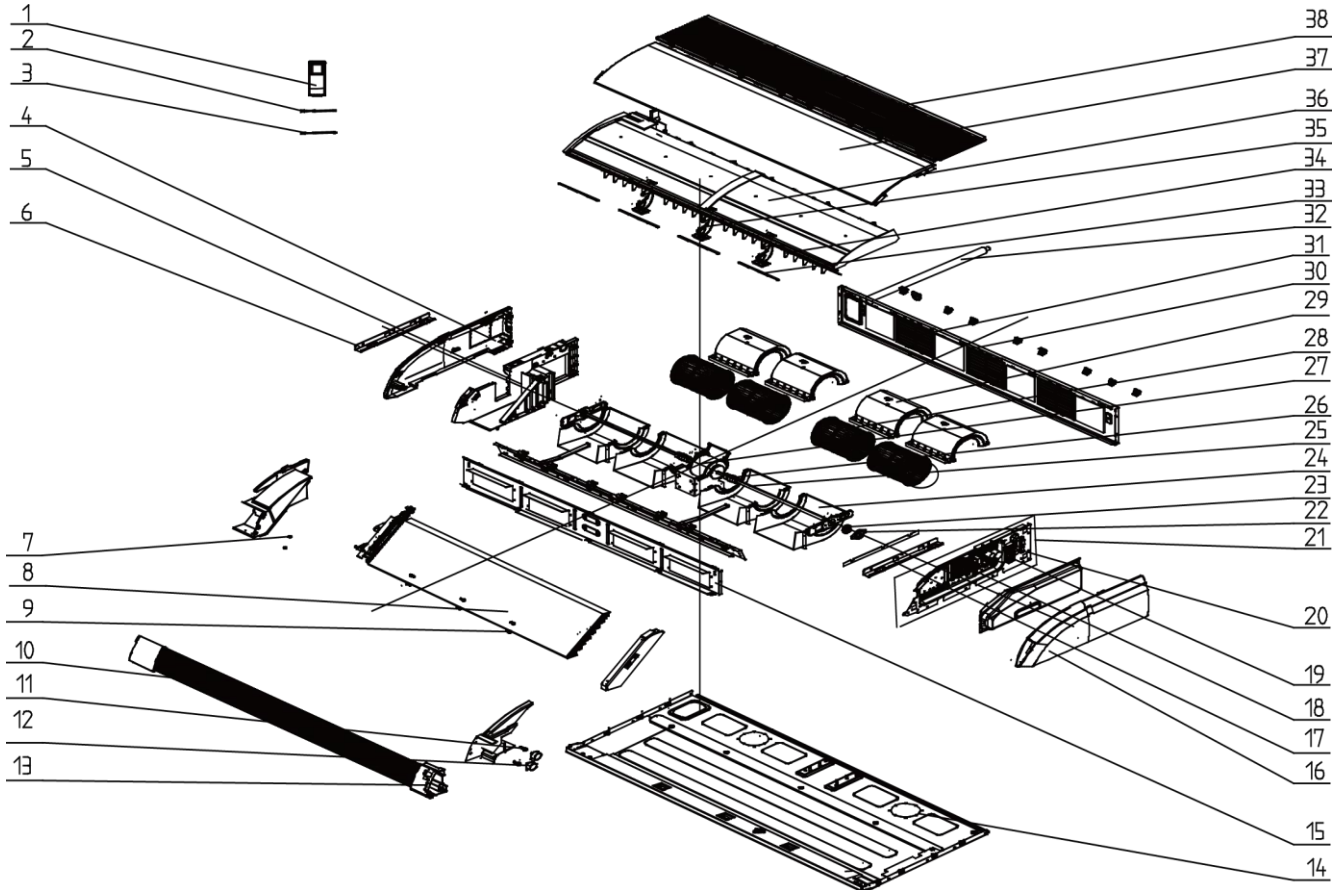

No.	Material name	Finished Product Code	Remarks
1	Remote Controller	305001060024	1
2	Ambient Temperature Sensor	3900012123	1
3	Tube Sensor	3900020720G	1
4	Right Cover Plate	26909400071	1
5	Right Side Plate	26909400074	1
6	Installation Supporting Frame(right)	01809402	1
7	Axial Bush	10542704	2
8	Evaporator Assay	011001060183	1
9	Rotating Shaft 3	26909430	6
10	Guide Louver	200004500426	2
11	Crankshaft	200023000001	2
12	Stepping Motor	1521240206	2
13	Display Board	30294000009	1
14	Base Plate Assay	011007060032	1
15	Clapboard Sub-Assay	01249400019	1
16	Left Cover Plate	26909400070	1
17	Installation Supporting Frame(Left)	01809401	1
18	Main Board	300002060226	1
19	Terminal Board	42018000551	1
20	Terminal Board	42000100000202	1
21	Electric Box Assay	100002003030	1
22	Support Of Motor Bearing	01792408	2
23	O-Gasket of Bearing	76512404	1
24	Propeller Housing(Lower)	200230000001	4
25	Roller Wheel	700004000001	2
26	Joint Slack	73018731	2
27	Brushless DC Motor	15709400005	1
28	Centrifugal Fan	103003000001	4
29	Propeller Housing(Upper)	200230000002	4
30	Rear Side Plate Sub-Assay	017051000006	1
31	Filter Sub-Assay	111001000001	3
32	Drainage Pipe Sub-Assay	05235434	1
33	Swing Lever	10582009	4
34	Air Louver	200007000001	20
35	Supporter(Guide Louver)	26909400076	3
36	Water Tray	200063000002	1
37	Top Cover	01269400013P	1
38	Front Grill Sub-assay	26909400066	4

Appendices

1 Resistance/temperature lists of temperature sensors

1.1 Voltage list of 15 kΩ temperature sensors (including ODU and IDU temperature sensors)

Temperature (°C)	Resistance (kΩ)	Voltage (V)	Temperature (°C)	Resistance (kΩ)	Voltage (V)
-20	144	0.311	71	2.523	2.825
-19	138.1	0.323	72	2.439	2.838
-18	128.6	0.345	73	2.358	2.852
-17	121.6	0.362	74	2.28	2.865
-16	115	0.381	75	2.205	2.877
-15	108.7	0.4	76	2.133	2.889
-14	102.9	0.42	77	2.064	2.901
-13	97.4	0.44	78	1.997	2.912
-12	92.22	0.462	79	1.933	2.923
-11	87.35	0.484	80	1.871	2.934
-10	82.75	0.506	81	1.811	2.945
-9	78.43	0.53	82	1.754	2.955
-8	74.35	0.554	83	1.699	2.964
-7	70.5	0.579	84	1.645	2.974
-6	66.88	0.605	85	1.594	2.983
-5	63.46	0.631	86	1.544	2.992
-4	60.23	0.658	87	1.497	3.001
-3	57.18	0.686	88	1.451	3.009
-2	54.31	0.714	89	1.408	3.017
-1	51.59	0.743	90	1.363	3.025
0	49.02	0.773	91	1.322	3.033
1	46.8	0.801	92	1.282	3.04
2	44.31	0.835	93	1.244	3.047
3	42.14	0.866	94	1.207	3.054
4	40.09	0.899	95	1.171	3.061
5	38.15	0.931	96	1.136	3.068
6	36.32	0.965	97	1.103	3.074
7	34.58	0.998	98	1.071	3.08
8	32.94	1.033	99	1.039	3.086
9	31.38	1.067	100	1.009	3.092
10	29.9	1.102	101	0.98	3.098
11	28.51	1.138	102	0.952	3.103

Temperature (°C)	Resistance (kΩ)	Voltage (V)	Temperature (°C)	Resistance (kΩ)	Voltage (V)
12	27.18	1.174	103	0.925	3.108
13	25.92	1.21	104	0.898	3.114
14	24.73	1.246	105	0.873	3.119
15	23.6	1.282	106	0.848	3.123
16	22.53	1.319	107	0.825	3.128
17	21.51	1.356	108	0.802	3.133
18	20.54	1.393	109	0.779	3.137
19	19.63	1.429	110	0.758	3.141
20	18.75	1.467	111	0.737	3.145
21	17.93	1.503	112	0.717	3.15
22	17.14	1.54	113	0.697	3.153
23	16.39	1.577	114	0.678	3.157
24	15.68	1.613	115	0.66	3.161
25	15	1.65	116	0.642	3.165
26	14.36	1.686	117	0.625	3.168
27	13.74	1.722	118	0.608	3.171
28	13.16	1.758	119	0.592	3.175
29	12.6	1.793	120	0.577	3.178
30	12.07	1.829	121	0.561	3.181
31	11.57	1.863	122	0.547	3.184
32	11.09	1.897	123	0.532	3.187
33	10.63	1.931	124	0.519	3.19
34	10.2	1.964	125	0.505	3.192
35	9.779	1.998	126	0.492	3.195
36	9.382	2.03	127	0.48	3.198
37	9.003	2.062	128	0.467	3.2
38	8.642	2.094	129	0.456	3.203
39	5.997	2.125	130	0.444	3.205
41	7.653	2.185	131	0.433	3.207
42	7.352	2.215	132	0.422	3.21
43	7.065	2.243	133	0.412	3.212
44	6.791	2.272	134	0.401	3.214
45	6.529	2.299	135	0.391	3.216
46	6.278	2.326	136	0.382	3.218
47	6.038	2.353	137	0.372	3.22
48	5.809	2.379	138	0.363	3.222
49	5.589	2.404	139	0.355	3.224
50	5.379	2.429	140	0.346	3.226
51	5.179	2.453	141	0.338	3.227
52	4.986	2.477	142	0.33	3.229
53	4.802	2.5	143	0.322	3.231
54	4.625	2.522	144	0.314	3.232
55	4.456	2.544	145	0.307	3.234

Temperature (°C)	Resistance (kΩ)	Voltage (V)	Temperature (°C)	Resistance (kΩ)	Voltage (V)
56	4.294	2.566	146	0.299	3.235
57	4.139	2.586	147	0.292	3.237
58	3.99	2.607	148	0.286	3.238
59	3.848	2.626	149	0.279	3.24
60	3.711	2.646	150	0.273	3.241
61	3.579	2.664	151	0.266	3.242
62	3.454	2.682	152	0.261	3.244
63	3.333	2.7	153	0.254	3.245
64	3.217	2.717	154	0.248	3.246
65	3.105	2.734	155	0.243	3.247
66	2.998	2.75	156	0.237	3.249
67	2.898	2.766	157	0.232	3.25
68	2.797	2.781	158	0.227	3.251
69	2.702	2.796	159	0.222	3.252
70	2.611	2.811	160	0.217	3.253

1.2 Voltage list of 20 kΩ pipeline temperature sensors (including temperature sensors for defroster, IDU and ODU pipes)

Temperature (°C)	Resistance (kΩ)	Voltage (V)	Temperature (°C)	Resistance (kΩ)	Voltage (V)
-30	361.8	0.173	66	3.998	2.75
-29	339.8	0.183	67	3.861	2.766
-28	319.2	0.195	68	3.729	2.781
-27	300	0.206	69	3.603	2.796
-26	282.2	0.218	70	3.481	2.811
-25	265.5	0.231	71	3.364	2.825
-24	249.9	0.245	72	3.252	2.838
-23	235.3	0.259	73	3.144	2.852
-22	221.6	0.273	74	3.04	2.865
-21	208.9	0.288	75	2.94	2.877
-20	196.9	0.304	76	2.844	2.889
-19	181.4	0.328	77	2.752	2.901
-18	171.4	0.345	78	2.663	2.912
-17	162.1	0.362	79	2.577	2.923
-16	153.3	0.381	80	2.495	2.934
-15	145	0.4	81	2.415	2.944
-14	137.2	0.42	82	2.339	2.954
-13	129.9	0.44	83	2.265	2.964
-12	123	0.462	84	2.194	2.974
-11	116.5	0.484	85	2.125	2.983

Temperature (°C)	Resistance (kΩ)	Voltage (V)	Temperature (°C)	Resistance (kΩ)	Voltage (V)
-10	110.3	0.507	86	2.059	2.992
-9	104.6	0.53	87	1.996	3.001
-8	99.13	0.554	88	1.934	3.009
-7	94	0.579	89	1.875	3.017
-6	89.17	0.605	90	1.818	3.025
-5	84.61	0.631	91	1.763	3.033
-4	80.31	0.658	92	1.71	3.04
-3	76.24	0.686	93	1.658	3.047
-2	72.41	0.714	94	1.609	3.054
-1	68.79	0.743	95	1.561	3.061
0	65.37	0.773	96	1.515	3.068
1	62.13	0.804	97	1.47	3.074
2	59.08	0.835	98	1.427	3.08
3	56.19	0.866	99	1.386	3.086
4	53.46	0.898	100	1.346	3.092
5	50.87	0.931	101	1.307	3.098
6	48.42	0.965	102	1.269	3.103
7	46.11	0.998	103	1.233	3.108
8	43.92	1.033	104	1.198	3.114
9	41.84	1.067	105	1.164	3.119
10	39.87	1.102	106	1.131	3.123
11	38.01	1.138	107	1.099	3.128
12	36.24	1.174	108	1.069	3.133
13	34.57	1.209	109	1.039	3.137
14	32.98	1.246	110	1.01	3.141
15	31.47	1.282	111	0.9825	3.145
16	30.04	1.319	112	0.9556	3.15
17	28.68	1.356	113	0.9295	3.153
18	27.39	1.393	114	0.9043	3.157
19	26.17	1.429	115	0.8799	3.161
20	25.01	1.466	116	0.8562	3.165
21	23.9	1.503	117	0.8333	3.168
22	22.85	1.54	118	0.8111	3.171
23	21.85	1.577	119	0.7895	3.175
24	20.9	1.614	120	0.7687	3.178
25	20	1.65	121	0.7485	3.181
26	19.14	1.686	122	0.7289	3.184
27	18.32	1.722	123	0.7099	3.187
28	17.55	1.758	124	0.6915	3.19
29	16.8	1.793	125	0.6736	3.192
30	16.1	1.828	126	0.6563	3.195
31	15.43	1.863	127	0.6395	3.198
32	14.79	1.897	128	0.6232	3.2

Temperature (°C)	Resistance (kΩ)	Voltage (V)	Temperature (°C)	Resistance (kΩ)	Voltage (V)
33	14.18	1.931	129	0.6074	3.203
34	13.59	1.965	130	0.5921	3.205
35	13.04	1.998	131	0.5772	3.207
36	12.51	2.03	132	0.5627	3.21
37	12	2.063	133	0.5487	3.212
38	11.52	2.094	134	0.5351	3.214
39	11.06	2.125	135	0.5219	3.216
40	10.62	2.155	136	0.509	3.218
41	10.2	2.185	137	0.4966	3.22
42	9.803	2.215	138	0.4845	3.222
43	9.42	2.243	139	0.4727	3.224
44	9.054	2.272	140	0.4613	3.226
45	8.705	2.299	141	0.4502	3.227
46	8.37	2.326	142	0.4394	3.229
47	8.051	2.353	143	0.4289	3.231
48	7.745	2.379	144	0.4187	3.232
49	7.453	2.404	145	0.4088	3.234
50	7.173	2.429	146	0.3992	3.235
51	6.905	2.453	147	0.3899	3.237
52	6.648	2.477	148	0.3808	3.238
53	6.403	2.5	149	0.3719	3.24
54	6.167	2.522	150	0.3633	3.241
55	5.942	2.544	151	0.3549	3.242
56	5.726	2.565	152	0.3468	3.244
57	5.519	2.586	153	0.3389	3.245
58	5.32	2.607	154	0.3312	3.246
59	5.13	2.626	155	0.3237	3.247
60	4.948	2.646	156	0.3164	3.249
61	4.773	2.664	157	0.3093	3.25
62	4.605	2.682	158	0.3024	3.251
63	4.443	2.7	159	0.2956	3.252
64	4.289	2.717	160	0.2891	3.253
65	4.14	2.734			

1.3 Voltage list of 50 kΩ discharge temperature sensors (including discharge air temperature sensor)

Temperature (°C)	Resistance (kΩ)	Voltage (V)	Temperature (°C)	Resistance (kΩ)	Voltage (V)
-30	911.56	0.036	61	11.736	1.518
-29	853.66	0.038	62	11.322	1.548
-28	799.98	0.041	63	10.925	1.577
-27	750.18	0.043	64	10.544	1.606
-26	703.92	0.046	65	10.178	1.635
-25	660.93	0.049	66	9.8269	1.664
-24	620.94	0.052	67	9.4896	1.693
-23	583.72	0.056	68	9.1655	1.722
-22	549.04	0.059	69	8.9542	1.741
-21	516.71	0.063	70	8.5551	1.778
-20	486.55	0.066	71	5.9676	1.806
-19	458.4	0.07	72	7.9913	1.834
-18	432.1	0.075	73	7.7257	1.862
-17	407.51	0.079	74	7.4702	1.889
-16	384.51	0.084	75	7.2245	1.916
-15	362.99	0.088	76	6.9882	1.943
-14	342.83	0.094	77	6.7608	1.969
-13	323.94	0.099	78	6.542	1.995
-12	306.23	0.104	79	6.3315	2.021
-11	289.61	0.11	80	6.1288	2.046
-10	274.02	0.116	81	5.9336	2.071
-9	259.37	0.123	82	5.7457	2.096
-8	245.61	0.129	83	5.5647	2.12
-7	232.67	0.136	84	5.3903	2.144
-6	220.5	0.143	85	5.2223	2.168
-5	209.05	0.151	86	5.0605	2.191
-4	195.97	0.158	87	4.9044	2.214
-3	188.12	0.167	88	4.7541	2.237
-2	178.65	0.175	89	4.6091	2.259
-1	169.68	0.184	90	4.4693	2.281
0	161.02	0.193	91	4.3345	2.302
1	153	0.202	92	4.2044	2.323
2	145.42	0.212	93	4.0789	2.344
3	135.96	0.223	94	3.9579	2.364
4	131.5	0.233	95	3.841	2.384
5	126.17	0.242	96	3.7283	2.404
6	119.08	0.256	97	3.6194	2.423

Temperature (°C)	Resistance (kΩ)	Voltage (V)	Temperature (°C)	Resistance (kΩ)	Voltage (V)
7	113.37	0.267	98	3.5143	2.442
8	107.96	0.28	99	3.4128	2.46
9	102.85	0.292	100	3.3147	2.478
10	98.006	0.306	101	3.22	2.496
11	93.42	0.319	102	3.1285	2.514
12	89.075	0.333	103	3.0401	2.531
13	84.956	0.348	104	2.9547	2.547
14	81.052	0.362	105	2.8721	2.564
15	77.349	0.378	106	2.7922	2.58
16	73.896	0.393	107	2.715	2.595
17	70.503	0.41	108	2.6404	2.611
18	67.338	0.427	109	2.5682	2.626
19	64.333	0.444	110	2.4983	2.64
20	61.478	0.462	111	2.4308	2.655
21	58.766	0.48	112	2.3654	2.669
22	56.189	0.499	113	2.3021	2.682
23	53.738	0.518	114	2.2409	2.696
24	51.408	0.537	115	2.1816	2.709
25	49.191	0.558	116	2.1242	2.722
26	47.082	0.578	117	2.0686	2.734
27	45.074	0.599	118	2.0148	2.747
28	43.163	0.621	119	1.9626	2.759
29	41.313	0.643	120	1.9123	2.77
30	39.61	0.665	121	1.8652	2.781
31	37.958	0.688	122	1.8158	2.793
32	36.384	0.711	123	1.7698	2.804
33	34.883	0.735	124	1.7253	2.814
34	33.453	0.759	125	1.6821	2.825
35	32.088	0.784	126	1.6402	2.835
36	30.787	0.809	127	1.5996	2.845
37	29.544	0.835	128	1.5602	2.855
38	28.359	0.86	129	1.522	2.864
39	27.227	0.886	130	1.485	2.873
40	26.147	0.913	131	1.449	2.882
41	25.114	0.94	132	1.4141	2.891
42	24.128	0.967	133	1.3803	2.9
43	23.186	0.994	134	1.3474	2.908
44	22.286	1.022	135	1.3155	2.916
45	21.425	1.05	136	1.2846	2.924
46	20.601	1.078	137	1.2545	2.932
47	19.814	1.107	138	1.2233	2.94
48	19.061	1.136	139	1.1969	2.947
49	18.34	1.164	140	1.1694	2.955

Temperature (°C)	Resistance (kΩ)	Voltage (V)	Temperature (°C)	Resistance (kΩ)	Voltage (V)
50	17.651	1.193	141	1.1476	2.96
51	16.99	1.223	142	1.1166	2.969
52	16.358	1.252	143	1.0913	2.975
53	15.753	1.281	144	1.0667	2.982
54	15.173	1.311	145	1.0429	2.988
55	14.618	1.34	146	1.0197	2.995
56	14.085	1.37	147	0.9971	3.001
57	13.575	1.4	148	0.9752	3.007
58	13.086	1.429	149	0.9538	3.013
59	12.617	1.459	150	0.9331	3.018
60	12.368	1.475			

2. Temperature/Pressure List of Refrigerant

R32							
Pressure	Temperature		Pressure	Temperature		Pressure	Temperature
Kpa	°C		Kpa	°C		Kpa	°C
100	-51.909		1250	14.153		2400	38.688
150	-43.635		1300	15.52		2450	39.529
200	-37.323		1350	16.847		2500	40.358
250	-32.15		1400	18.138		2550	41.173
300	-27.731		1450	19.395		2600	41.977
350	-23.85		1500	20.619		2650	42.769
400	-20.378		1550	21.813		2700	43.55
450	-17.225		1600	22.978		2750	44.32
500	-14.331		1650	24.116		2800	45.079
550	-11.65		1700	25.229		2850	45.828
600	-9.1503		1750	26.317		2900	46.567
650	-6.8046		1800	27.382		2950	47.296
700	-4.5925		1850	28.425		3000	48.015
750	-2.4975		1900	29.447		3050	48.726
800	-0.50613		1950	30.448		3100	49.428
850	1.393		2000	31.431		3150	50.121
900	3.2092		2050	32.395		3200	50.806
950	4.9506		2100	33.341		3250	51.482
1000	6.624		2150	34.271		3300	52.15
1050	8.2352		2200	35.184		3350	52.811
1100	9.7896		2250	36.082		3400	53.464
1150	11.291		2300	36.965		3450	54.11
1200	12.745		2350	37.834		3500	54.748

3. Refrigerant Notice/Concentration

This air conditioner uses R32 refrigerant. The construction area for installation, operation and storage of the air conditioner must be larger than the minimum construction area. The minimum area for installation is determined by:

1、Refrigerant charging quantity for the entire system (ex-factory charging quantity + additional charging quantity);

2、Checking out in the applicable tables:

(1) For indoor unit, confirm the model of indoor unit and check the corresponding table.

(2) For outdoor unit that is installed or placed indoors, select the corresponding table according to the height of the room

Height of the room	Select the applicable table
<1.8m	Floor standing type
≥1.8m	Wall mounted type

3、Refer to the following table to check out the minimum construction area

Ceiling type		Wall mounted type		Floor standing type	
Weight (kg)	Area (m ²)	Weight (kg)	Area (m ²)	Weight (kg)	Area (m ²)
<1.224	—	<1.224	—	<1.224	—
1.224	0.956	1.224	1.43	1.224	12.9
1.4	1.25	1.4	1.87	1.4	16.8
1.6	1.63	1.6	2.44	1.6	22.0
1.8	2.07	1.8	3.09	1.8	27.8
2.0	2.55	2.0	3.81	2.0	34.3
2.2	3.09	2.2	4.61	2.2	41.5
2.4	3.68	2.4	5.49	2.4	49.4
2.6	4.31	2.6	6.44	2.6	58.0
2.8	5.00	2.8	7.47	2.8	67.3
3.0	5.74	3.0	8.58	3.0	77.2
3.2	6.54	3.2	9.76	3.2	87.9
3.4	7.38	3.4	11.0	3.4	99.2
3.6	8.27	3.6	12.4	3.6	111
3.8	9.22	3.8	13.8	3.8	124
4.0	10.2	4.0	15.3	4.0	137
4.2	11.3	4.2	16.8	4.2	151
4.4	12.4	4.4	18.5	4.4	166
4.6	13.5	4.6	20.2	4.6	182
4.8	14.7	4.8	22.0	4.8	198
5.0	16.0	5.0	23.8	5.0	215
5.2	17.3	5.2	25.8	5.2	232

5.4	18.6		5.4	27.8		5.4	250
5.6	20.0		5.6	29.9		5.6	269
5.8	21.5		5.8	32.1		5.8	289
6.0	23.0		6.0	34.3		6.0	309
6.2	24.5		6.2	36.6		6.2	330
6.4	26.1		6.4	39.1		6.4	351
6.6	27.8		6.6	41.5		6.6	374
6.8	29.5		6.8	44.1		6.8	397
7.0	31.3		7.0	46.7		7.0	420
7.2	33.1		7.2	49.4		7.2	445
7.4	34.9		7.4	52.2		7.4	470
7.6	36.9		7.6	55.1		7.6	496
7.8	38.8		7.8	58.0		7.8	522
8.0	10.8		8.0	61.0		8.0	549

4. Operation Tools

The following tools will be used: 1) Liquid-level gauge; 2) Screwdriver; 3) Electric driven rotary hammer; 4) Drill; 5) Pipe expander; 6) Torque wrench; 7) Open-end wrench; 8) Pipe cutter; 9) Leak detector; 10) Vacuum pump; 11) Pressure gauge; 12) Universal meter; 13) Hexagon wrench; 14) Tapeline.



JF00303775



GREE ELECTRIC APPLIANCES, INC. OF ZHUHAI 519070

Add: West Jinji Rd, Qianshan Zhuhai, Guangdong, China

Tel: (+86-756)8522218

Fax: (+86-756)8669426

E-mail: gree@gree.com.cn www.gree.com