



Service Manual

MODEL: GWHD(14)NK3BO
GWHD(18)NK3DO
GWHD(24)NK3DO
GWHD(24)NK3EO
GWHD(28)NK3BO
GWHD(36)NK3AO
GWHD(42)NK3AO
(Refrigerant R410A)

Table of Contents

Summary and Features	1
1. Safety Precautions	2
2. Specifications	3
3. Construction Views	7
4. Refrigerant System Diagram	9
5. Schematic Diagram	11
5.1 Electrical Data.....	11
5.2 Electrical Wiring.....	11
5.3 Printed Circuit Board.....	16
6. Description of Each Control Operation	20
7. Installation Manual	26
7.1 Electrical Connections.....	26
7.2 Installing the Outdoor Unit.....	29
7.3 Installation Dimension Diagram.....	30
7.4 Check after Installation.....	31
7.5 Models:36K and 42K.....	32
8. Exploded Views and Parts List	41
9. Troubleshooting	61
9.1 Malfunction Indicator.....	61
9.2 Malfunction Checking and Elimination.....	62
9.3 Models:36k and 42K.....	73
10. Removal Procedure	85

Summary and Features

GWHD(14)NK3BO
GWHD(18)NK3DO

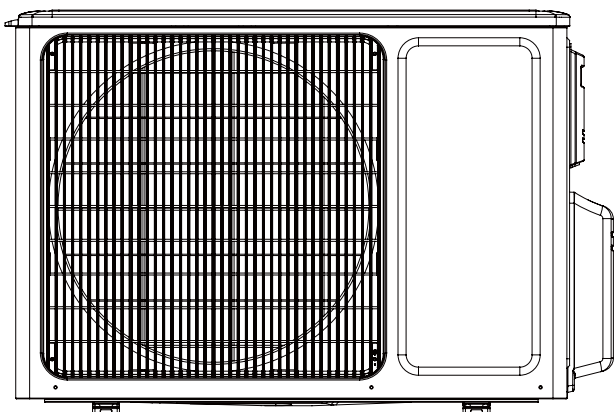

GWHD(24)NK3DO
GWHD(24)NK3EO
GWHD(28)NK3BO

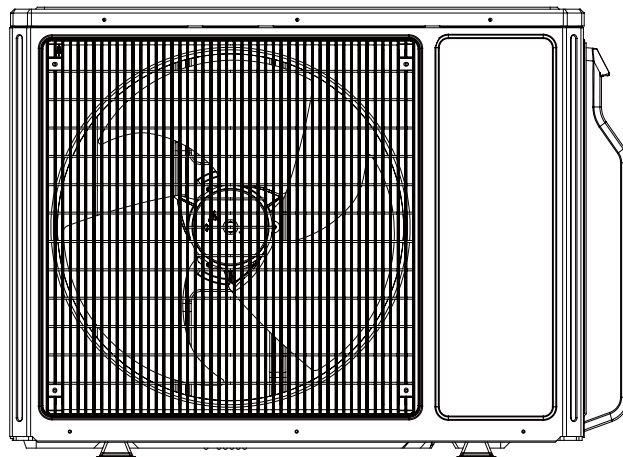

GWHD(36)NK3AO

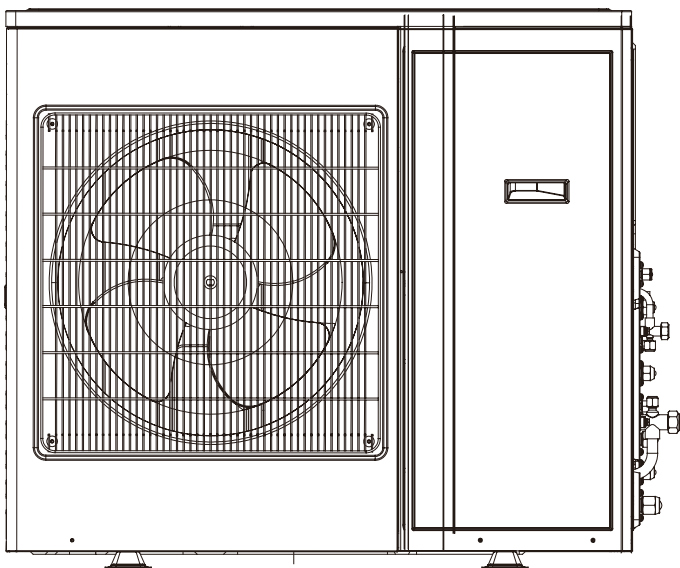

GWHD(42)NK3AO

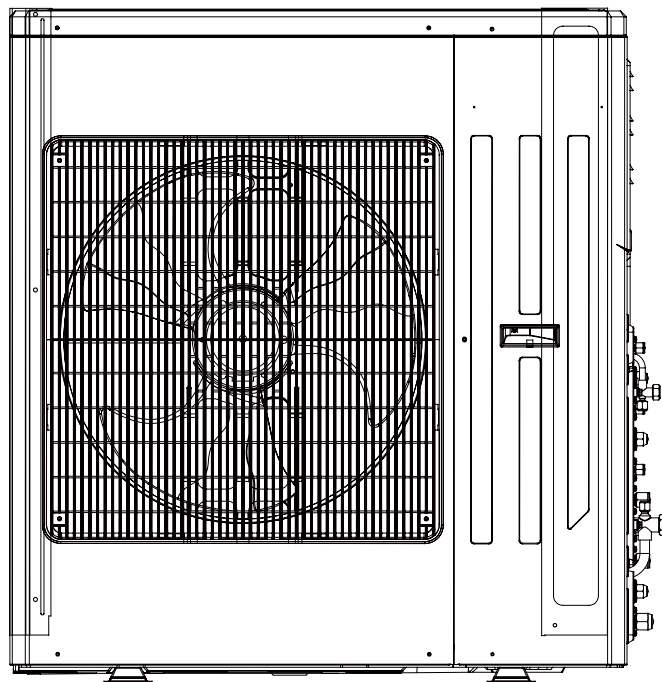

1. Safety Precautions

Installing, starting up, and servicing air conditioner can be hazardous due to system pressure, electrical components, and equipment location, etc.

Only trained, qualified installers and service personnel are allowed to install, start-up, and service this equipment. Untrained personnel can perform basic maintenance functions such as cleaning coils. All other operations should be performed by trained service personnel.

When handling the equipment, observe precautions in the manual and on tags, stickers, and labels attached to the equipment. Follow all safety codes. Wear safety glasses and work gloves. Keep quenching cloth and fire extinguisher nearby when brazing.

Read the instructions thoroughly and follow all warnings or cautions in literature and attached to the unit. Consult local building codes and current editions of national as well as local electrical codes.

Recognize the following safety information:



Warning Incorrect handling could result in personal injury or death.



Caution Incorrect handling may result in minor injury, or damage to product or property.

- Make sure the outdoor unit is installed on a stable, level surface with no accumulation of snow, leaves, or trash beside.
- Make sure the ceiling/wall is strong enough to bear the weight of the unit.
- Make sure the noise of the outdoor unit does not disturb neighbors.
- Follow all the installation instructions to minimize the risk of damage from earthquakes, typhoons or strong winds.
- Avoid contact between refrigerant and fire as it generates poisonous gas.
- Apply specified refrigerant only. Never have it mixed with any other refrigerant. Never have air remain in the refrigerant line as it may lead to rupture and other hazards.
- Make sure no refrigerant gas is leaking out when installation is completed.
- Should there be refrigerant leakage, the density of refrigerant in the air shall in no way exceed its limited value, or it may lead to explosion.
- Keep your fingers and clothing away from any moving parts.
- Clear the site after installation. Make sure no foreign objects are left in the unit.
- Always ensure effective grounding for the unit.



Warning

All electric work must be performed by a licensed technician according to local regulations and the instructions given in this manual.

- Before installing, modifying, or servicing system, main electrical disconnect switch must be in the OFF position. There may be more than 1 disconnect switch. Lock out and tag switch with a suitable warning label.
- Never supply power to the unit unless all wiring and tubing are completed, reconnected and checked.
- This system adopts highly dangerous electrical voltage. Incorrect connection or inadequate grounding can cause personal injury or death. Stick to the wiring diagram and all the instructions when wiring.
- Have the unit adequately grounded in accordance with local electrical codes.
- Have all wiring connected tightly. Loose connection may lead to overheating and a possible fire hazard.

All installation or repair work shall be performed by your dealer or a specialized subcontractor as there is the risk of fire, electric shock, explosion or injury.



Caution

- Never install the unit in a place where a combustible gas might leak, or it may lead to fire or explosion.
- Make a proper provision against noise when the unit is installed at a telecommunication center or hospital.
- Provide an electric leak breaker when it is installed in a watery place.
- Never wash the unit with water.
- Handle unit transportation with care. The unit should not be carried by only one person if it is more than 20kg.
- Never touch the heat exchanger fins with bare hands.
- Never touch the compressor or refrigerant piping without wearing glove.
- Do not have the unit operate without air filter.
- Should any emergency occur, stop the unit and disconnect the power immediately.
- Properly insulate any tubing running inside the room to prevent the water from damaging the wall.

2. Specifications

Model	GWHD(14)NK3BO	GWHD(18)NK3DO
Product Code	CB228W0120	CB228W0080
Compressor Manufacturer/trademark	Shenyang SANYO	Shenyang SANYO
Compressor Model	C-6RZ146H1A	C-6RZ146H1A
Compressor Oil	FV50S	FV50S
Compressor Type	Rotary	Rotary
L.R.A. (A)	32	32
Compressor RLA(A)	4.54	4.54
Compressor Power Input(W)	1000	1000
Overload Protector	1NT11L-3979	1NT11L-3979
Throttling Method	Electronic Expansion Valve	Electronic Expansion Valve
Starting Method	Transducer starting	Transducer starting
Cooling Working Temp Range (°C)	-5 ≤ T ≤ 43	-5 ≤ T ≤ 43
Heating Working Temp Range (°C)	-10 ≤ T ≤ 24	-10 ≤ T ≤ 24
Condenser	Aluminum fin-copper tube	Aluminum fin-copper tube
Pipe Diameter	Φ9.52	Φ9.52
Rows-Fin Gap(mm)	2-1.4	2-1.4
Coil length (l) X height (H) X coil width (L)	800X44X559	800X44X559
Fan Motor Speed (rpm) (H/M/L)	880/700/500	880/700/500
Output of Fan Motor (W)	60	60
Fan Motor RLA(A)	0.56	0.56
Fan Motor Capacitor (μF)	4	4
Air Flow Volume of Outdoor Unit	2600/2300/1600	2600/2300/1600
Fan Type	Axial fan	Axial fan
Fan Diameter (mm)	Φ445	Φ445
Defrosting Method	Automatic Defrosting	Automatic Defrosting
Climate Type	T1	T1
Isolation	I	I
Moisture Protection	IP24	IP24
Permissible Excessive Operating Pressure for the Discharge Side(MPa)	3.8	3.8
Permissible Excessive Operating Pressure for the Suction Side(MPa)	1.2	1.2
Sound Pressure Level dB (A) (H/M/L)	56/53/50	56/53/50
Sound Power Level dB (A) (H/M/L)	66/63/60	66/63/60
Dimension (WXHXD) (mm)	903X596X378	903X596X378
Dimension of Carton Box (LXWXH) (mm)	945X417X630	945X417X630
Dimension of Package (LXWXH)(mm)	948X420X645	948X420X645
Net Weight /Gross Weight (kg)	43/48	43/48
Refrigerant Charge (kg)	R410A/1.40	R410A/1.40

The above data is subject to change without notice. Please refer to the nameplate of the unit.

Model of Outdoor Unit	GWHD(14)NK3BO	GWHD(18)NK3DO
Product Code	CB228W0121	CB228W0081
Compressor Manufacturer/trademark	MITSUBISHI ELECTRIC (GUANGZHOU)COMPRESSOR CO. LTD MITSUBISHI ELECTRIC	
Compressor Model	SNB130FGYMC	SNB130FGYMC
Compressor Oil	FV50S	FV50S
Compressor Type	Rotary	Rotary
L.R.A. (A)	27	27
Compressor RLA(A)	8.4	8.4
Compressor Power Input(W)	1245	1245
Overload Protector	1NT11L-6578	1NT11L-6578
Throttling Method	Electronic Expansion Valve	Electronic Expansion Valve
Starting Method	Transducer starting	Transducer starting
Cooling Working Temp Range (°C)	-5≤T≤48	-5≤T≤48
Heating Working Temp Range (°C)	-15≤T≤27	-15≤T≤27
Condenser	Aluminum fin-copper tube	Aluminum fin-copper tube
Pipe Diameter	Φ9.52	Φ9.52
Rows-Fin Gap(mm)	2-1.4	2-1.4
Coil length (l) X height (H) X coil width (L)	800X44X559	800X44X559
Fan Motor Speed (rpm) (H/M/L)	880/700/500	880/700/500
Output of Fan Motor (W)	60	60
Fan Motor RLA(A)	0.56	0.56
Fan Motor Capacitor (μF)	4	4
Air Flow Volume of Outdoor Unit	2600/2300/1600	2600/2300/1600
Fan Type	Axial fan	Axial fan
Fan Diameter (mm)	Φ445	Φ445
Defrosting Method	Automatic Defrosting	Automatic Defrosting
Climate Type	T1	T1
Isolation	I	I
Moisture Protection	IP24	IP24
Permissible Excessive Operating Pressure for the Discharge Side(MPa)	4.3	4.3
Permissible Excessive Operating Pressure for the Suction Side(MPa)	2.5	2.5
Sound Pressure Level dB (A) (H/M/L)	56/53/50	56/53/50
Sound Power Level dB (A) (H/M/L)	66/63/60	66/63/60
Dimension (WXHXD) (mm)	903X596X378	903X596X378
Dimension of Carton Box (LXWXH) (mm)	945X417X630	945X417X630
Dimension of Package (L/W/H)(mm)	948X420X645	948X420X645
Net Weight /Gross Weight (kg)	43/48	43/48
Refrigerant Charge (kg)	R410A/1.35	R410A/1.35

The above data is subject to change without notice. Please refer to the nameplate of the unit.

Model	GWHD(24)NK3DO	GWHD(24)NK3EO	GWHD(28)NK3BO
Product Code	CB228W0070	CB228W0100	CB228W0110
	CB228W0071	CB228W0101	CB228W0111
Compressor Manufacturer/trademark	MITSUBISHI ELECTRIC (GUANGZHOU)COMPRESSOR CO. LTD		
Compressor Model	TNB220FLHMC	TNB220FLHMC	TNB220FLHMC
Compressor Oil	FV50S	FV50S	FV50S
Compressor Type	Rotary	Rotary	Rotary
L.R.A. (A)	45	45	45
Compressor RLA(A)	9.7	9.7	9.7
Compressor Power Input(W)	2200	2200	2200
Overload Protector	CS-7C-1595	CS-7C-1595	CS-7C-1595
Throttling Method	Electronic Expansion Valve	Electronic Expansion Valve	Electronic Expansion Valve
Starting Method	Transducer starting	Transducer starting	Transducer starting
Cooling Working Temp Range (°C)	-5 ≤ T ≤ 43	-5 ≤ T ≤ 43	-5 ≤ T ≤ 43
Heating Working Temp Range (°C)	-10 ≤ T ≤ 24	-10 ≤ T ≤ 24	-10 ≤ T ≤ 24
Condenser	Aluminum fin-copper tube	Aluminum fin-copper tube	Aluminum fin-copper tube
Pipe Diameter	Φ9.52	Φ9.52	Φ9.52
Rows-Fin Gap(mm)	2-1.4	2-1.4	2-1.4
Coil length (l) X height (H) X coil width (L)	890X44X660	890X44X660	890X44X660
Fan Motor Speed (rpm) (H/M/L)	690/600/500	690/600/500	690/600/500
Output of Fan Motor (W)	60	60	60
Fan Motor RLA(A)	0.6	0.6	0.6
Fan Motor Capacitor (μF)	3.5	3.5	3.5
Air Flow Volume of Outdoor Unit	3300/2900/2400	3300/2900/2400	3300/2900/2400
Fan Type	Axial fan	Axial fan	Axial fan
Fan Diameter (mm)	Φ520	Φ520	Φ520
Defrosting Method	Automatic Defrosting	Automatic Defrosting	Automatic Defrosting
Climate Type	T1	T1	T1
Isolation	I	I	I
Moisture Protection	IP24	IP24	IP24
Permissible Excessive Operating Pressure for the Discharge Side(MPa)	3.8	3.8	3.8
Permissible Excessive Operating Pressure for the Suction Side(MPa)	1.2	1.2	1.2
Sound Pressure Level dB (A) (H/M/L)	58/54/52	58/54/52	59/56/53
Sound Power Level dB (A) (H/M/L)	68/64/62	68/64/62	69/66/63
Dimension (WXHXD) (mm)	963X700X396	963X700X396	963X700X396
Dimension of Carton Box (LXWXH) (mm)	1026X455X735	1026X455X735	1026X455X735
Dimension of Package (LXWXH)(mm)	1029X458X750	1029X458X750	1029X458X750
Net Weight /Gross Weight (kg)	59/64	59/64	60/65
Refrigerant Charge (kg)	R410A/2.4	R410A/2.2	R410A/2.2

The above data is subject to change without notice. Please refer to the nameplate of the unit.

Model of Outdoor Unit	GWHD(36)NK3AO	GWHD(42)NK3AO
Product Code	CN860W0011	CN860W0020
Compressor Manufacturer/trademark	MITSUBISHI ELECTRIC (GUANGZHOU)COMPRESSOR CO. LTD MITSUBISHI ELECTRIC	
Compressor Model	TNB220FLHMC	TNB306FPGMC
Compressor Oil	FV50S	FV50S
Compressor Type	Rotary	Rotary
L.R.A. (A)	/	/
Compressor RLA(A)	9.7	13.5
Compressor Power Input(W)	2200	3010
Overload Protector	CS-7C-1595	CS01F272H01
Throttling Method	Electronic Expansion Valve	Electronic Expansion Valve
Starting Method	Transducer starting	Transducer starting
Cooling Working Temp Range (°C)	-5 ≤ T ≤ 48	-5 ≤ T ≤ 48
Heating Working Temp Range (°C)	-15 ≤ T ≤ 27	-15 ≤ T ≤ 27
Condenser	Aluminum fin-copper tube	Aluminum fin-copper tube
Pipe Diameter	Φ9.52	Φ7.94
Rows-Fin Gap(mm)	2-1.4	2-1.4
Coil length (l) X height (H)Xcoil width (L)	818.7X44X813	994.45X38.1X1056
Fan Motor Speed (rpm) (H/M/L)	860/760/540	840/620/520
Output of Fan Motor (W)	60	140
Fan Motor RLA(A)	0.56	0.96
Fan Motor Capacitor (μF)	3	7
Air Flow Volume of Outdoor Unit	3000	5500
Fan Type	Axial fan	Axial fan
Fan Diameter (mm)	Φ450	Φ570
Defrosting Method	Automatic Defrosting	Automatic Defrosting
Climate Type	T1	T1
Isolation	I	I
Moisture Protection	IPX4	IPX4
Permissible Excessive Operating Pressure for the Discharge Side(MPa)	4.0	4.0
Permissible Excessive Operating Pressure for the Suction Side(MPa)	1.3	1.3
Sound Pressure Level dB (A) (H/M/L)	54/51/48	54/51/48
Sound Power Level dB (A) (H/M/L)	64/61/58	64/61/58
Dimension (WXHXD) (mm)	950X412X840	1015X440X1103
Dimension of Carton Box (LXWXH) (mm)	1100X450X905	1155X490X1220
Dimension of Package (LXWXH)(mm)	1103X453X920	1158X493X1235
Net Weight /Gross Weight (kg)	73/78	102/112
Refrigerant Charge (kg)	R410A/3.6	R410A/4.8

The above data is subject to change without notice. Please refer to the nameplate of the unit.

3. Construction Views

(1) Models: GWHD(14)NK3BO, GWHD(18)NK3DO

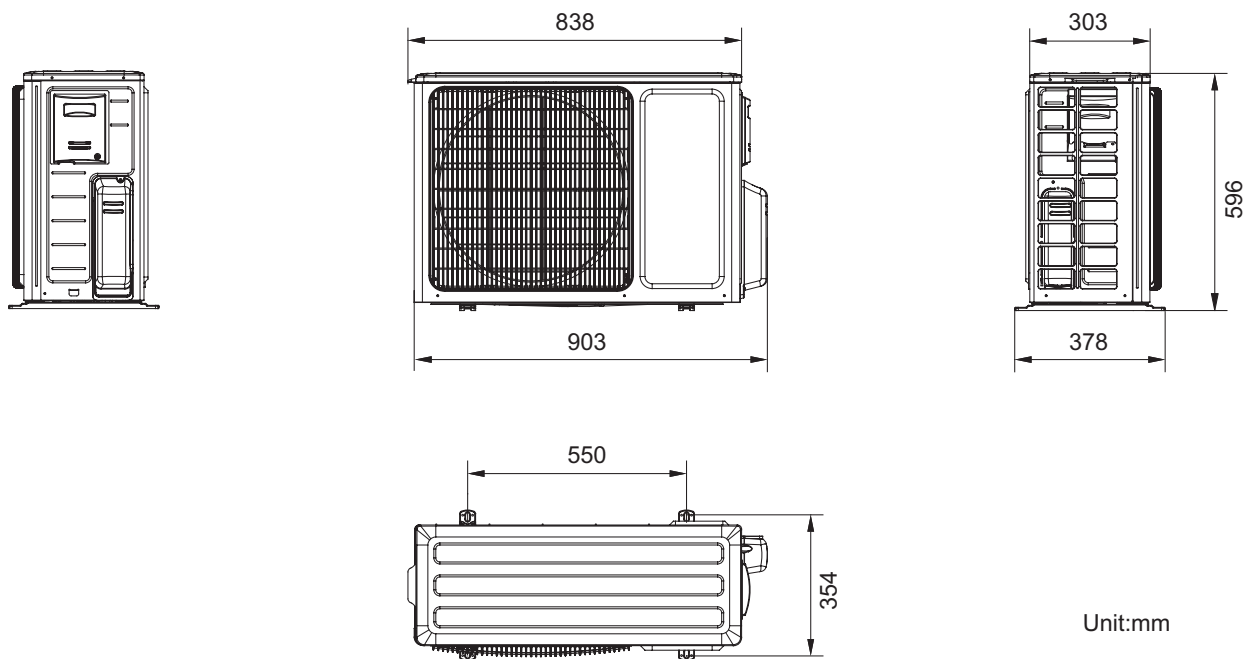

(2) Models: GWHD(24)NK3DO, GWHD(24)NK3EO, GWHD(28)NK3BO

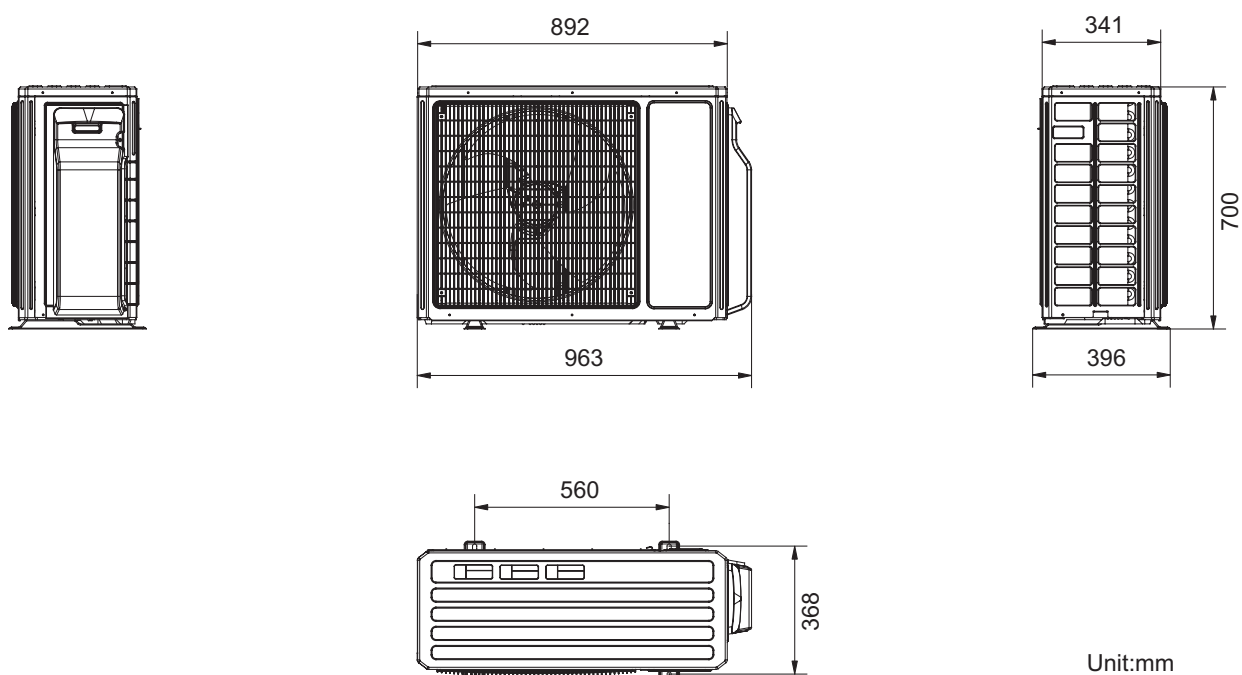

(3) Model: GWHD(36)NK3AO

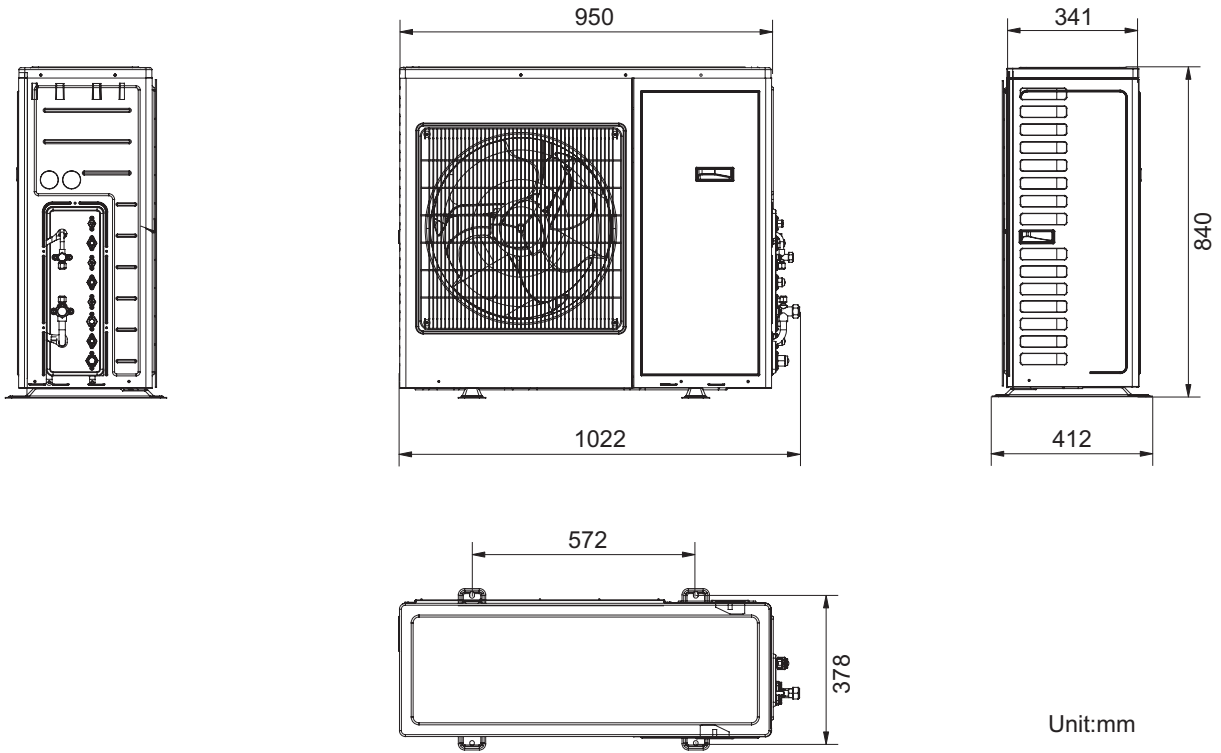

Unit:mm

(4) Model: GWHD(42)NK3AO

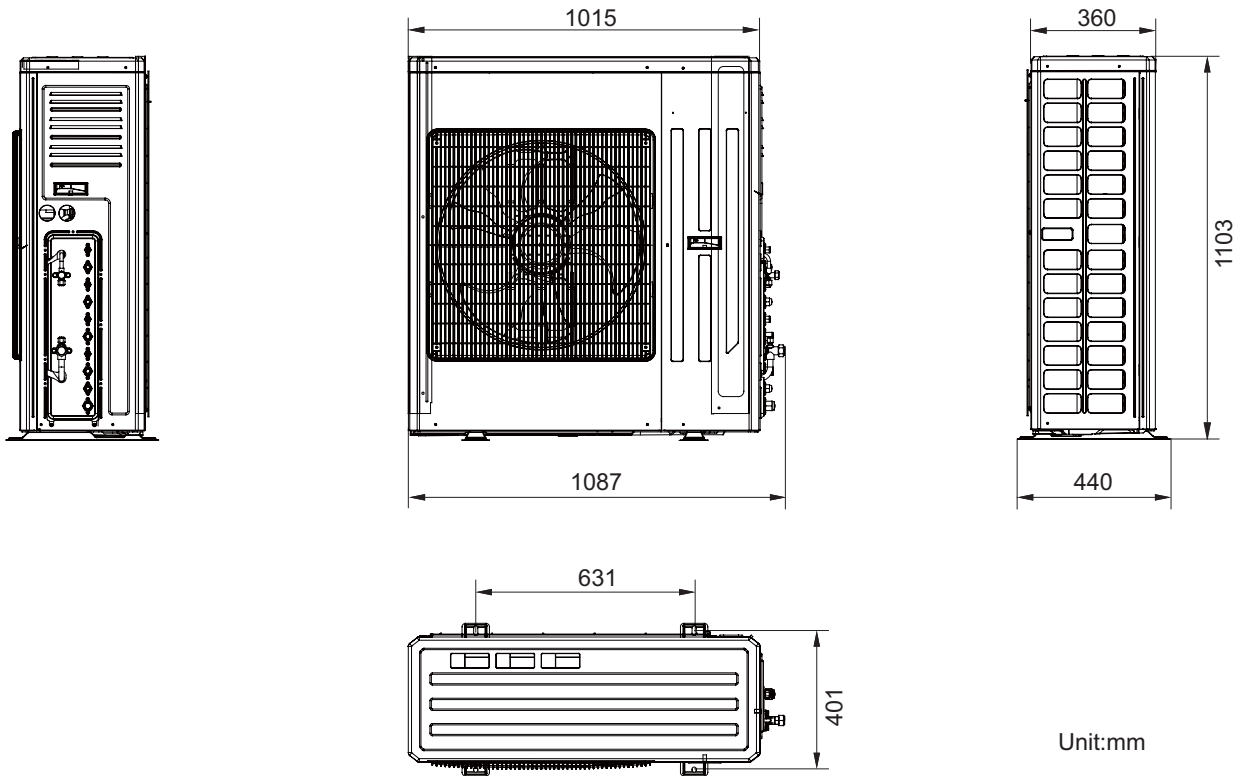

Unit:mm

4. Refrigerant System Diagram

Models:GWHD(14)NK3BO,GWHD(18)NK3DO,GWHD(24)NK3DO,GWHD(24)NK3EO,GWHD(28)NK3BO

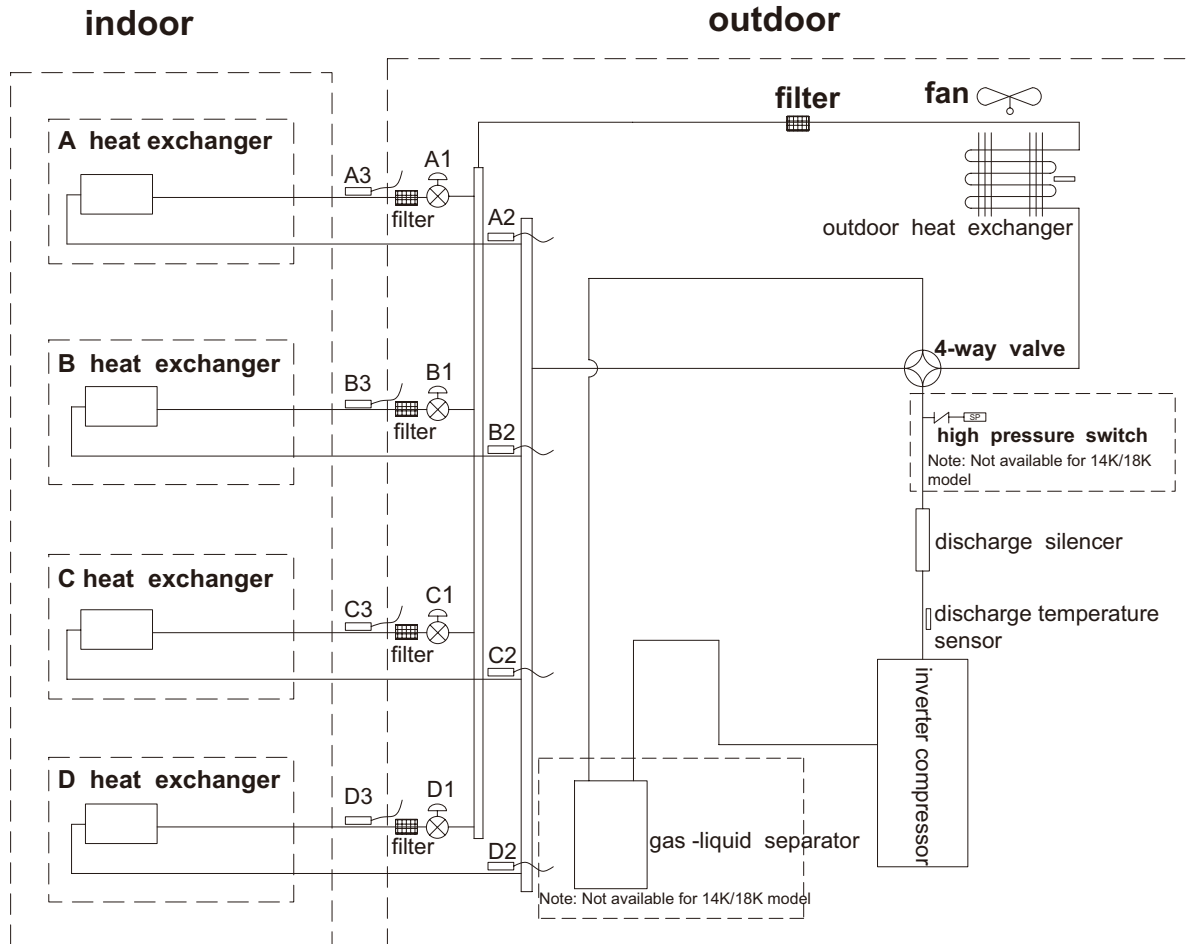

A1:A-unit electronic expansion valve **B1:B-unit electronic expansion valve**
C1:C-unit electronic expansion valve **D1:D-unit electronic expansion valve**
A2:A-unit gas pipe temperature sensor **B2:B-unit gas pipe temperature sensor**
C2:C-unit gas pipe temperature sensor **D2:D-unit gas pipe temperature sensor**
A3:A-unit liquid pipe temperature sensor **B3:B-unit liquid pipe temperature sensor**
C3:C-unit liquid pipe temperature sensor **D3:D-unit liquid pipe temperature sensor**

Models:GWHD(36)NK3AO,GWHD(42)NK3AO

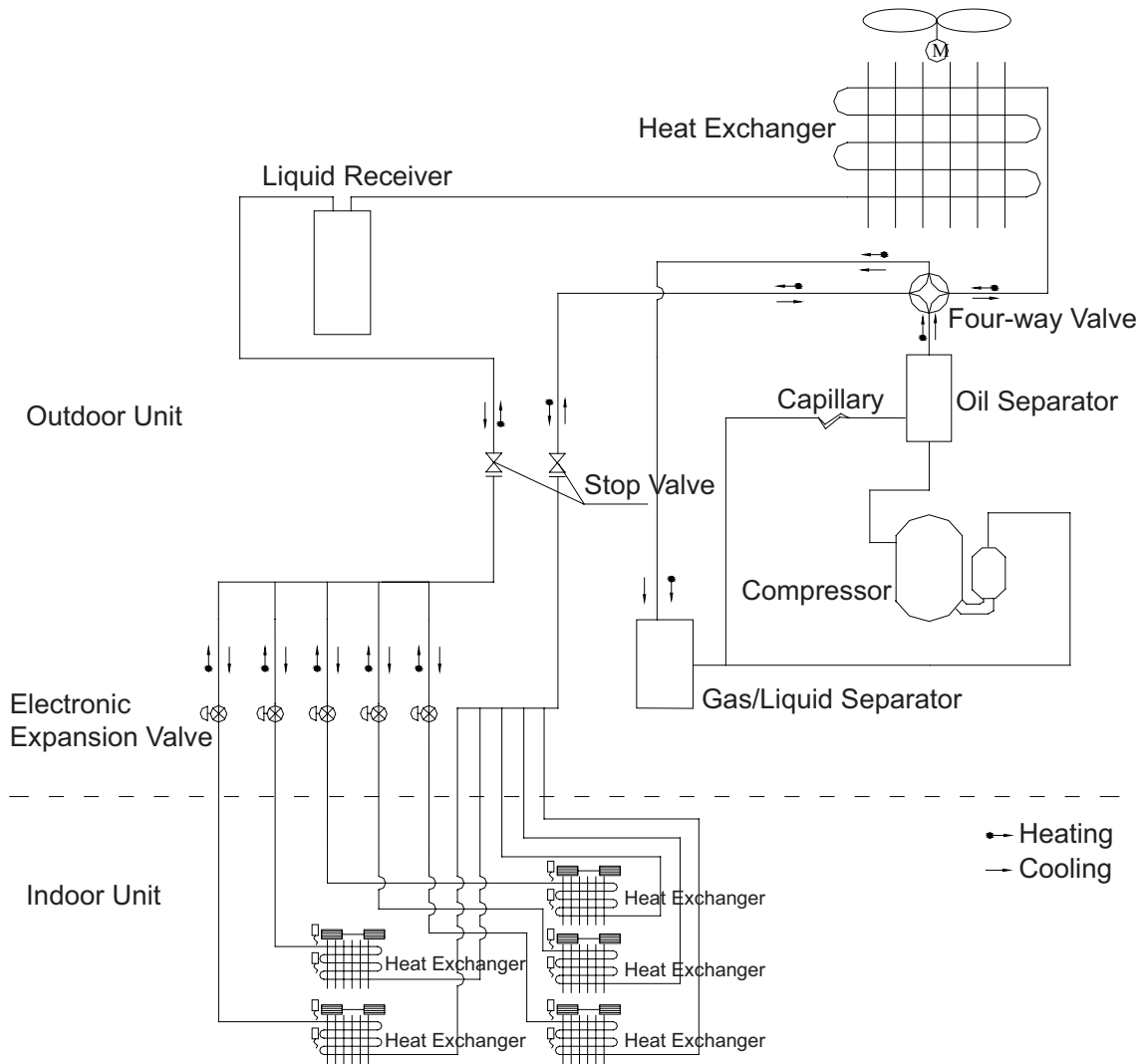

The outdoor and indoor units start to work once the power is switched on. During the cooling operation, the low temperature, low pressure refrigerant gas from the heat exchanger of each indoor unit gets together and then is taken into the compressor to be compressed into high temperature, high pressure gas, which will soon go to the heat exchanger of the outdoor unit to exchange heat with the outdoor air and then is turned into refrigerant liquid. After passing through the throttling device, the temperature and pressure of the refrigerant liquid will further decrease and then go to the main valve. After that, it will be divided and go to the heat exchanger of each indoor unit to exchange heat with the air which needs to be conditioned. Consequently, the refrigerant liquid become low temperature, low pressure refrigerant gas again. Such a refrigeration cycle goes round and round to achieve the desired cooling purpose. During the heating operation, the four-way valve is involved to make the refrigeration cycle run reversely. The refrigerant radiates heat in the heat exchanger of the indoor unit (so do the electric heating devices) and absorb heat in the heat exchanger of the outdoor unit for a heat pump heating cycle so as to achieve the desired heating purpose.

5. Schematic Diagram

5.1 Electrical Data

Meaning of marks

Symbol	Color symbol	Symbol	Color symbol	Symbol	Parts name
WH	WHITE	GN	GREEN	SAT	OVERLOAD
YE	YELLOW	BN	BROWN	COMP	COMPRESSOR
RD	RED	BU	BLUE	⊕	PROTECTIVE EARTH
YEGN	YELLOW GREEN	BK	BLACK	/	/
VT	VIOLET	OG	ORANGE	/	/

5.2 Electrical Wiring

(1)Models:GWHD(14)NK3BO,GWHD(18)NK3DO

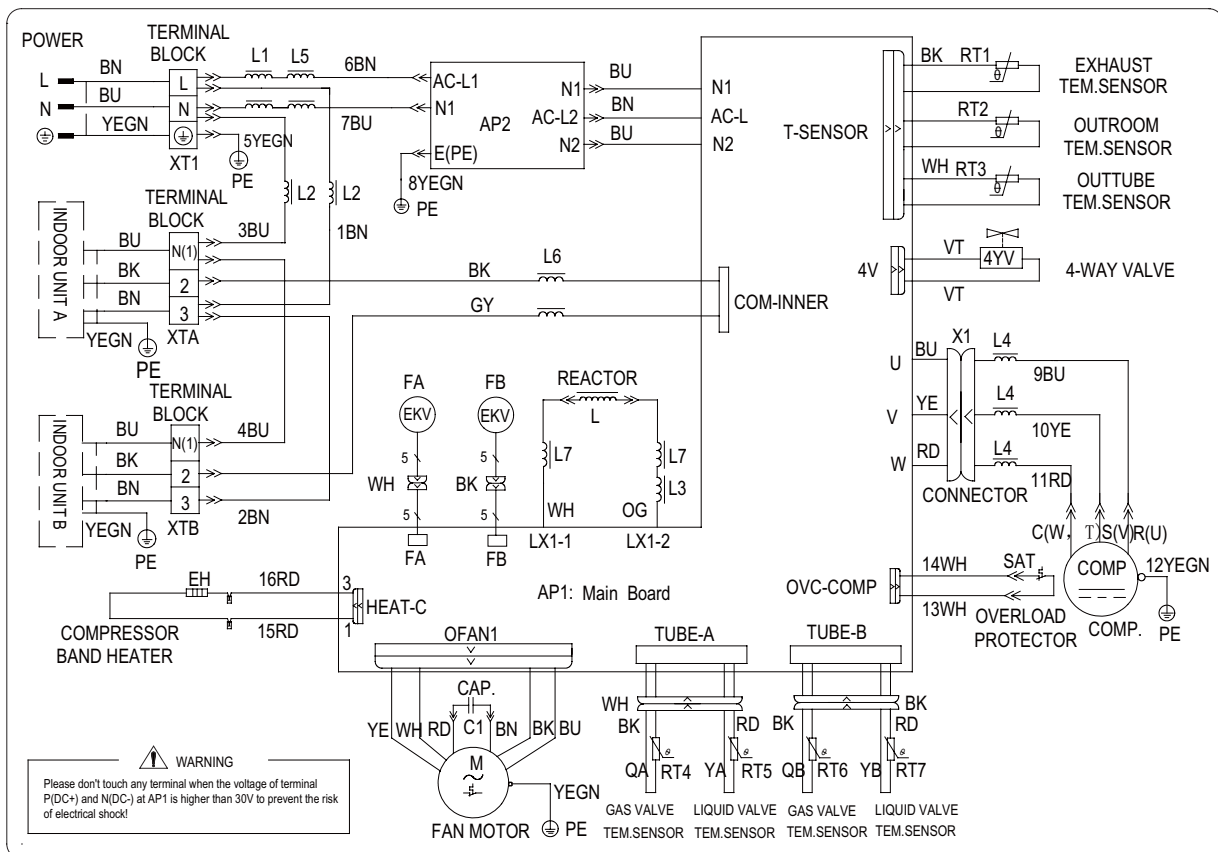

(2)Model:GWHD(24)NK3DO

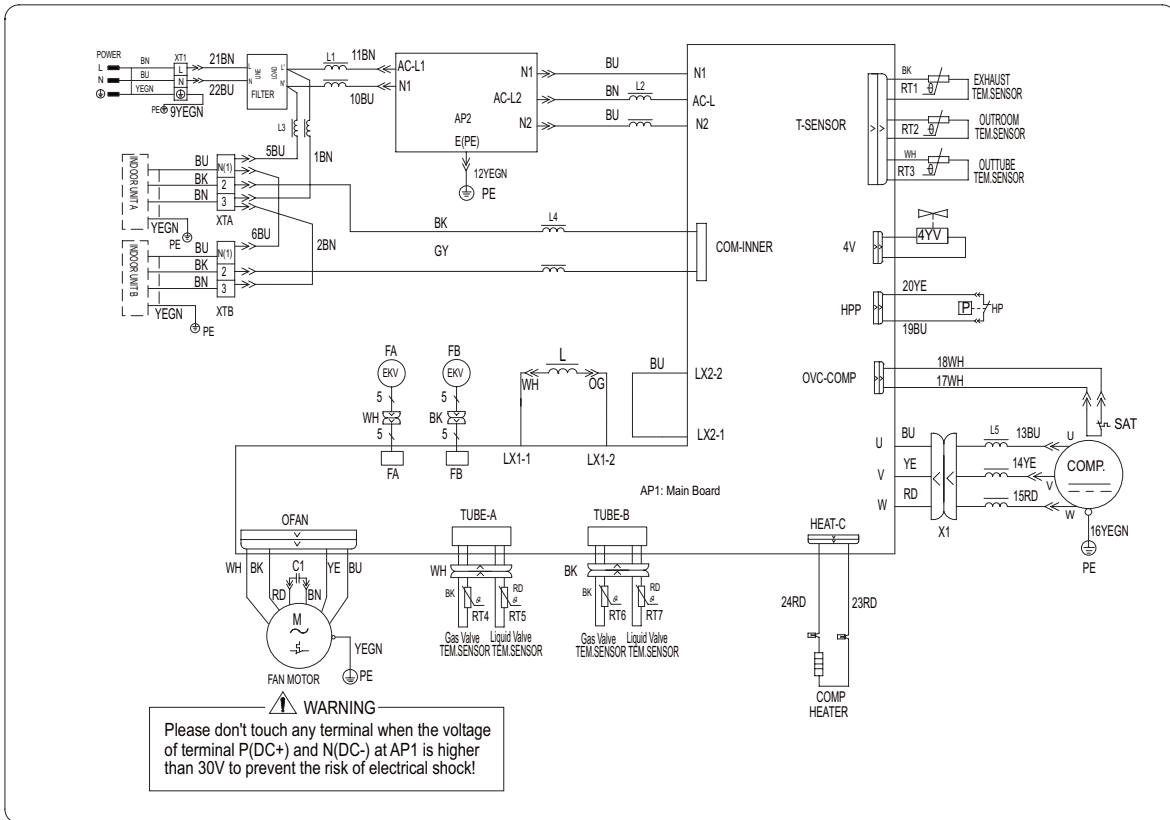

(3)Models:GWHD(24)NK3EO

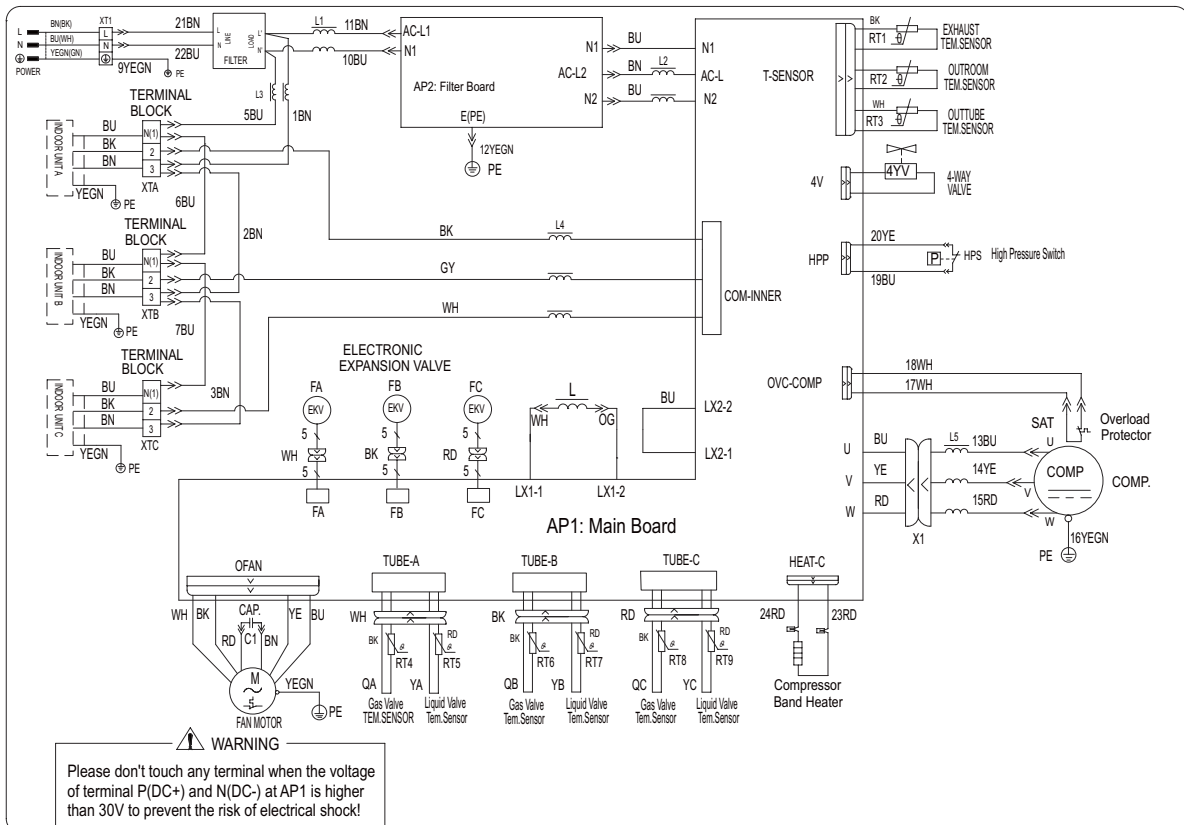

(4) Model:GWHD(28)NK3BO

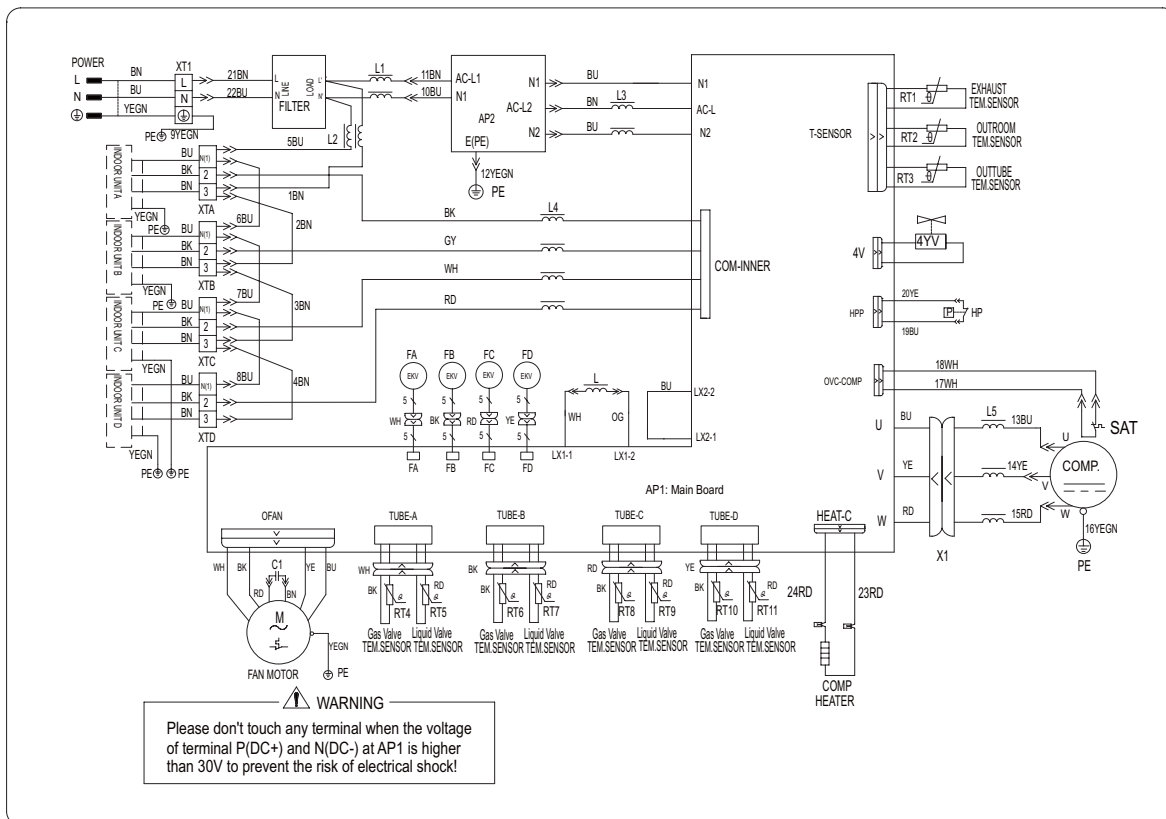

(5)Model:GWHD(36)NK3AO

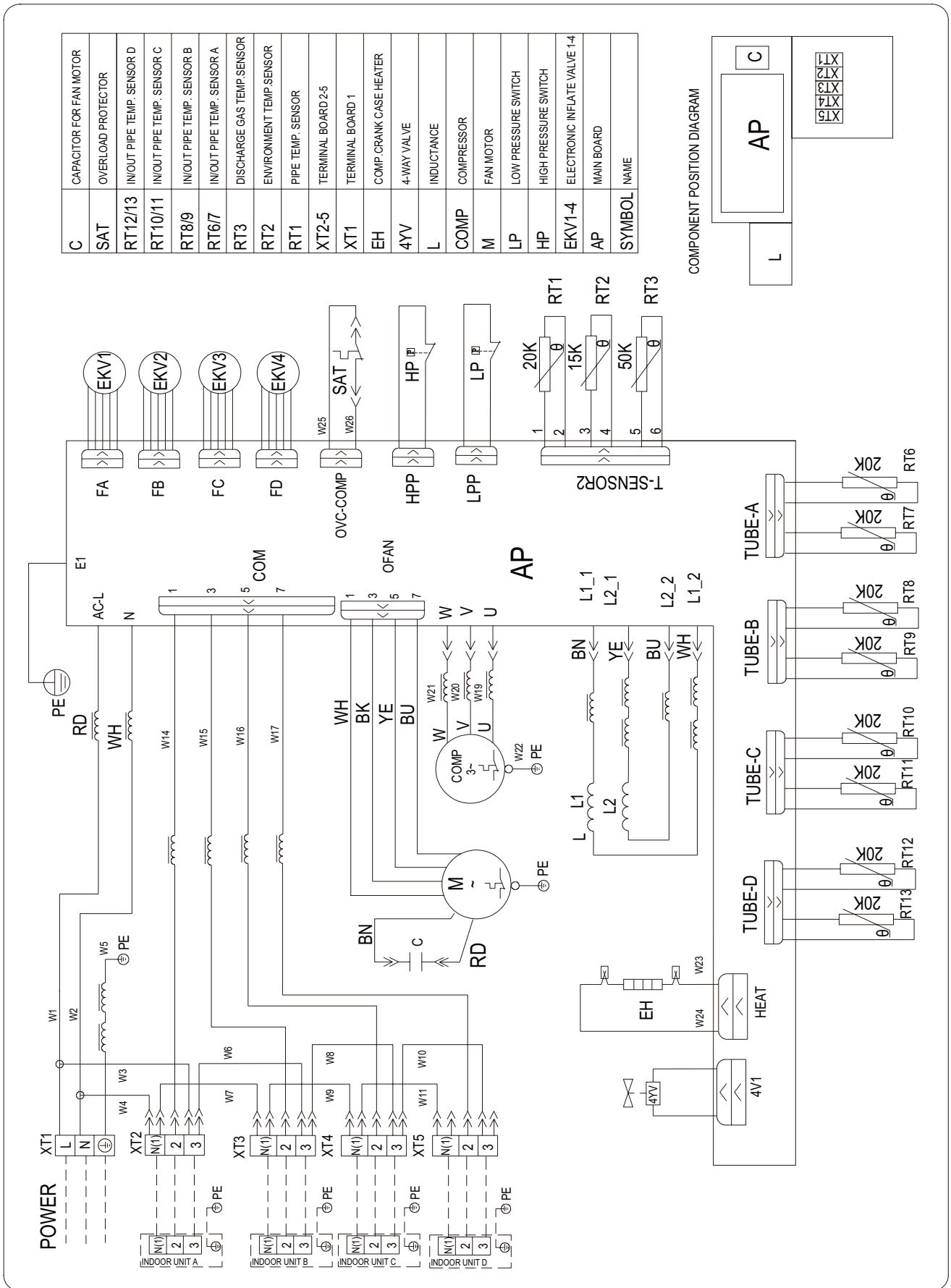

(6)Model:GWHD(42)NK3AO

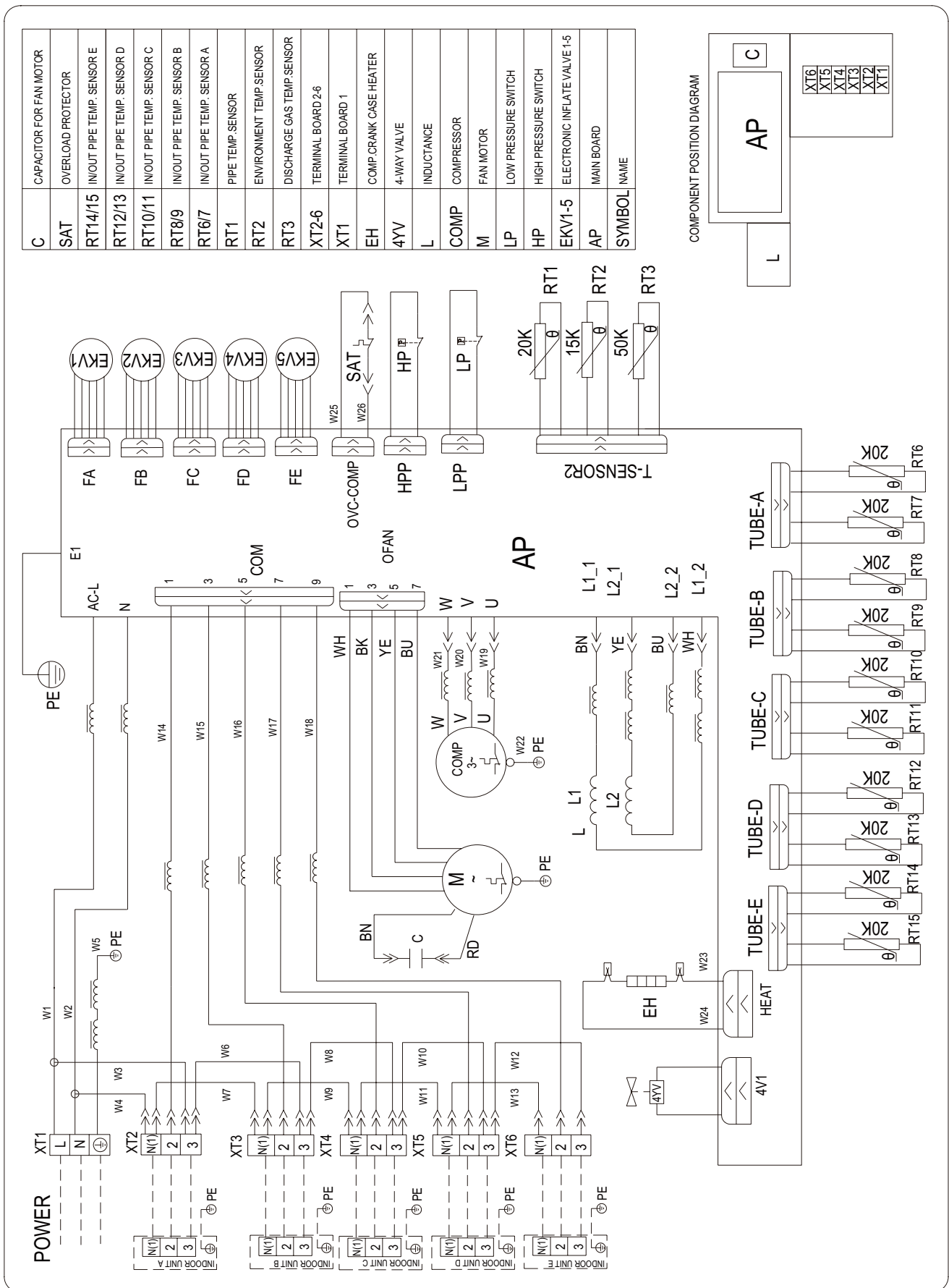

These circuit diagrams are subject to change without notice, please refer to the one supplied with the unit.

5.3 Printed Circuit Board

(1)Models:GWHD(14)NK3BO,GWHD(18)NK3DO

• TOP VIEW

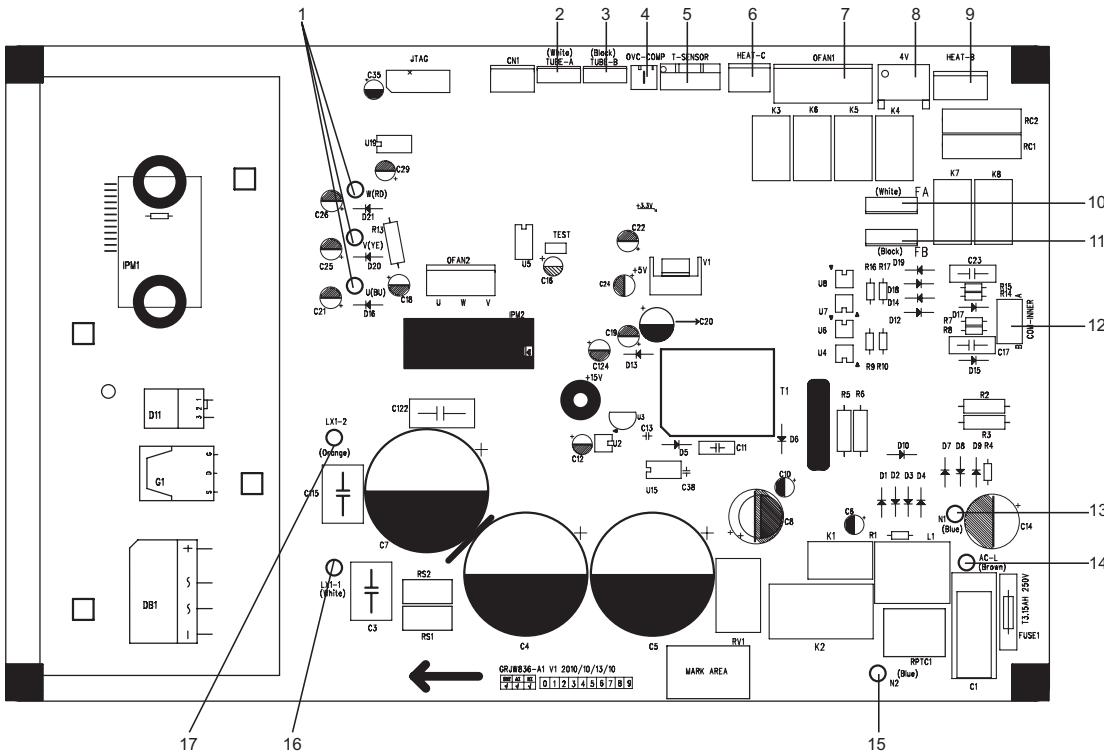

1	Compressor interface
2	Unit A liquid valve and gas valve
3	Unit B liquid valve and gas valve
4	Compressor overload protector
5	Temperature sensor
6	Compressor electric heater
7	Outdoor fan
8	4-way valve
9	Chassis electric heater (reserved)
10	Unit A electronic expansion valve
11	Unit B electronic expansion valve
12	Communication interface with indoor unit
13	Communication neutral wire
14	Live wire of power supply
15	Neutral wire of power supply
16	Reactor interface1
17	Reactor interface2

• BOTTOM VIEW

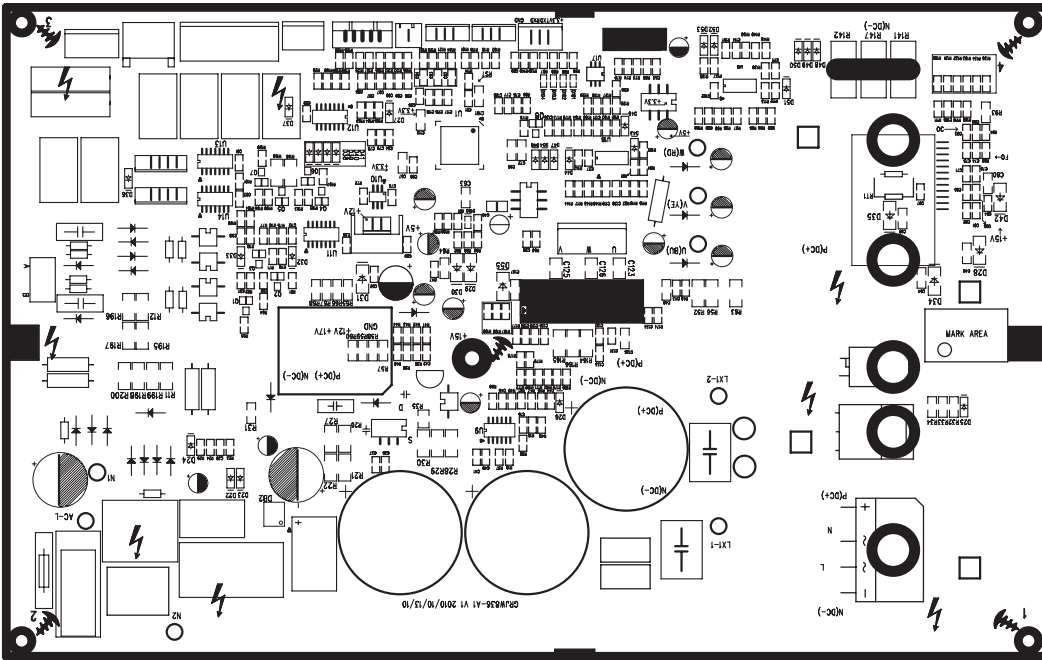

(2)Models:GWHD(24)NK3DO(CB228W0070),GWHD(24)NK3EO(CB228W0100),GWHD(28)NK3BO(CB228W0110)

● TOP VIEW

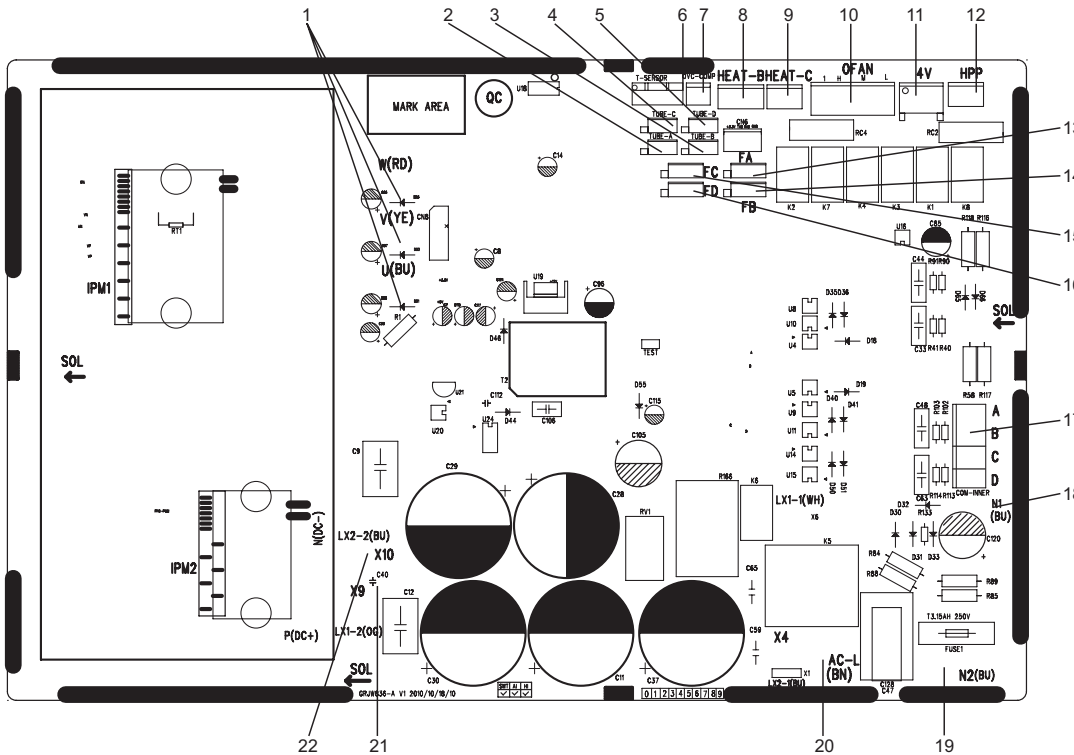

1	Compressor interface
2	Temperature sensor interface of unit A liquid valve and gas valve
3	Temperature sensor interface of unit B liquid valve and gas valve
4	Temperature sensor interface of unit C liquid valve and gas valve
5	Temperature sensor interface of unit D liquid valve and gas valve
6	Temperature sensor interface
7	Interface of compressor overload protector
8	Interface of chassis electric heater
9	Interface of compressor electric heater belt
10	Outdoor fan interface
11	4-way valve interface
12	High voltage protection interface
13	Interface of electronic expansion valve A
14	Interface of electronic expansion valve B
15	Interface of electronic expansion valve C
16	Interface of electronic expansion valve D
17	Communication wire interface
18	Communication neutral wire interface
19	Input neutral wire interface
20	Input live wire interface
21	PFC input live wire interface
22	PFC input neutral wire interface

● BOTTOM VIEW

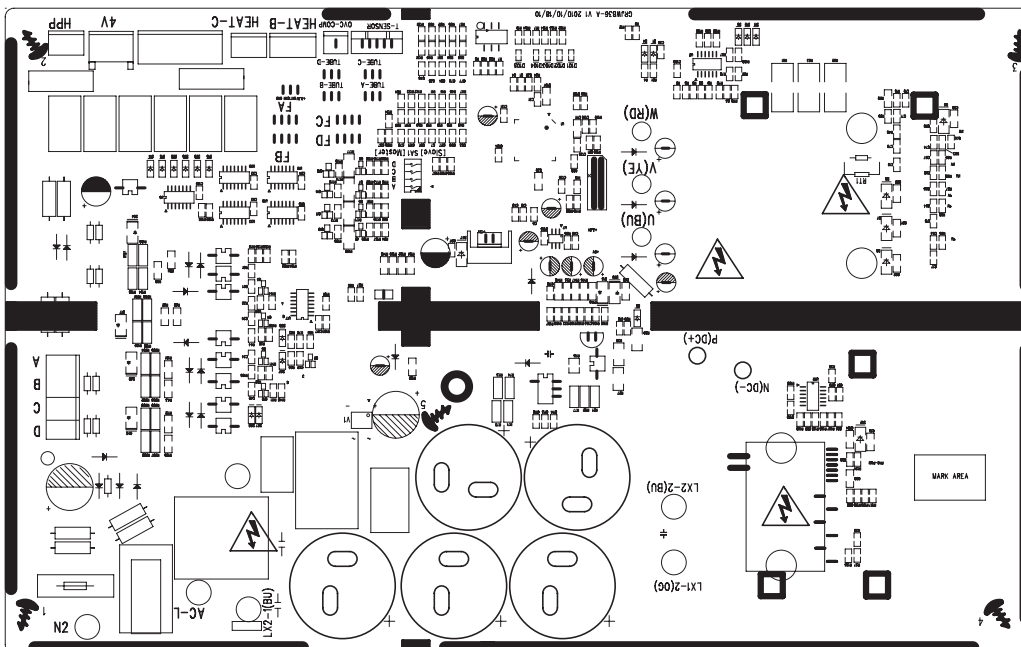

(3)Models:GWHD(24)NK3DO(CB228W0071),GWHD(24)NK3EO(CB228W0101),GWHD(28)NK3BO(CB228W0111)

● TOP VIEW

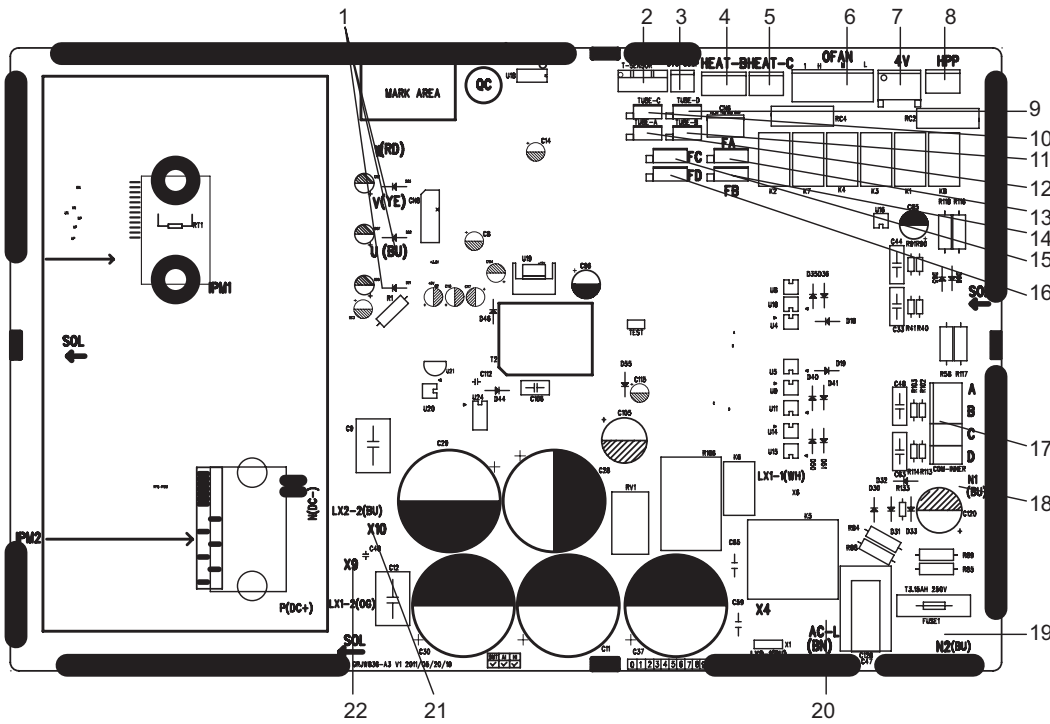

1	Interface of compressor
2	Interface of temperature sensor
3	Overload interface of compressor
4	Interface of electric heating tape for chassis
5	Interface of electric heating tape for compressor
6	Interface of outdoor unit
7	Interface of 4-way valve
8	Interface of high-pressure protection
9	Interface of temperature sensor for liquid valve and gas valve (unit D)
10	Interface of temperature sensor for liquid valve and gas valve (unit C)
11	Interface of temperature sensor for liquid valve and gas valve (unit B)
12	Interface of temperature sensor for liquid valve and gas valve (unit A)
13	Interface A pf electronic expansion valve
14	Interface B pf electronic expansion valve
15	Interface B pf electronic expansion valve
16	Interface D pf electronic expansion valve
17	Interface of communication wire
18	Interface of neutral wire for communication
19	Interface of input neutral wire
20	Interface of input live wire
21	Interface of PFC input neutral wire
22	Interface of PFC input live wire

● BOTTOM VIEW

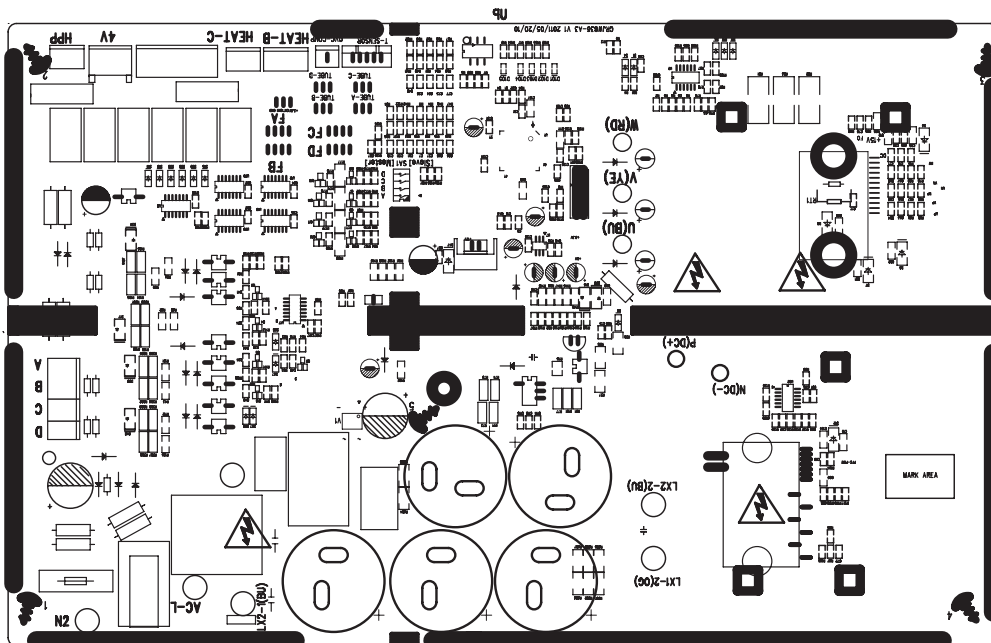

(4)Models:GWHD(36)NK3AO,GWHD(42)NK3AO

• TOP VIEW

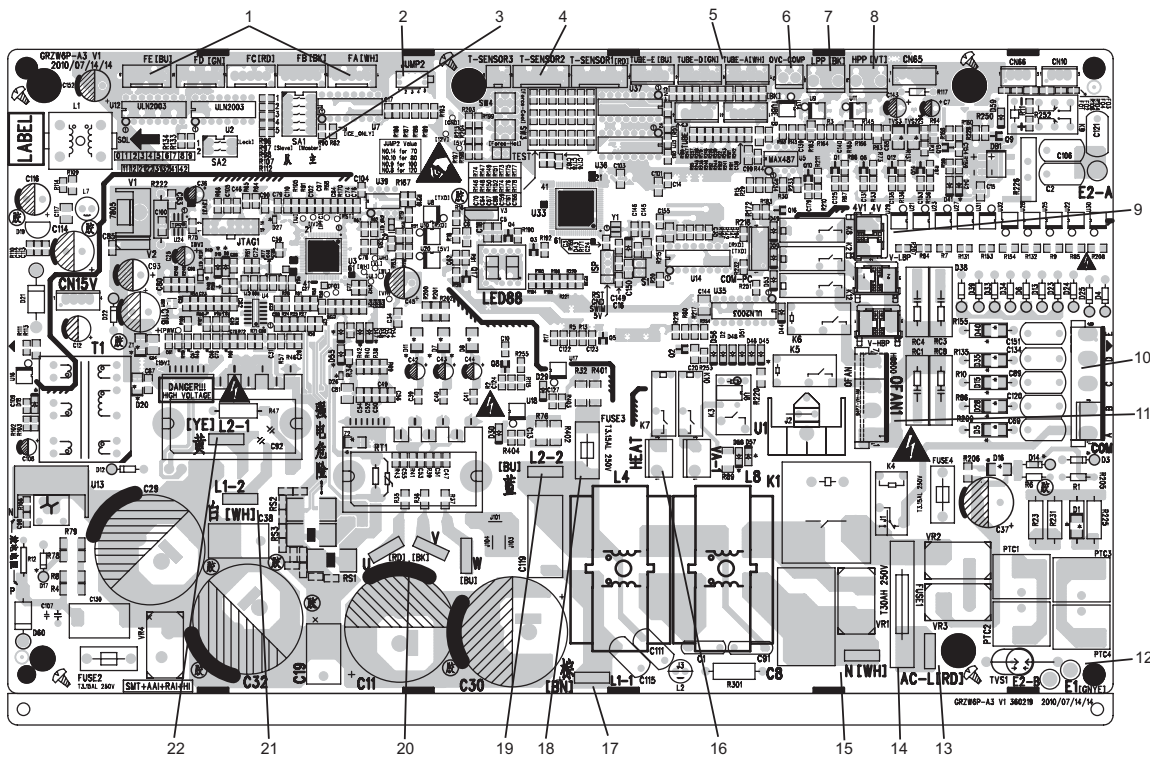

• BOTTOM VIEW

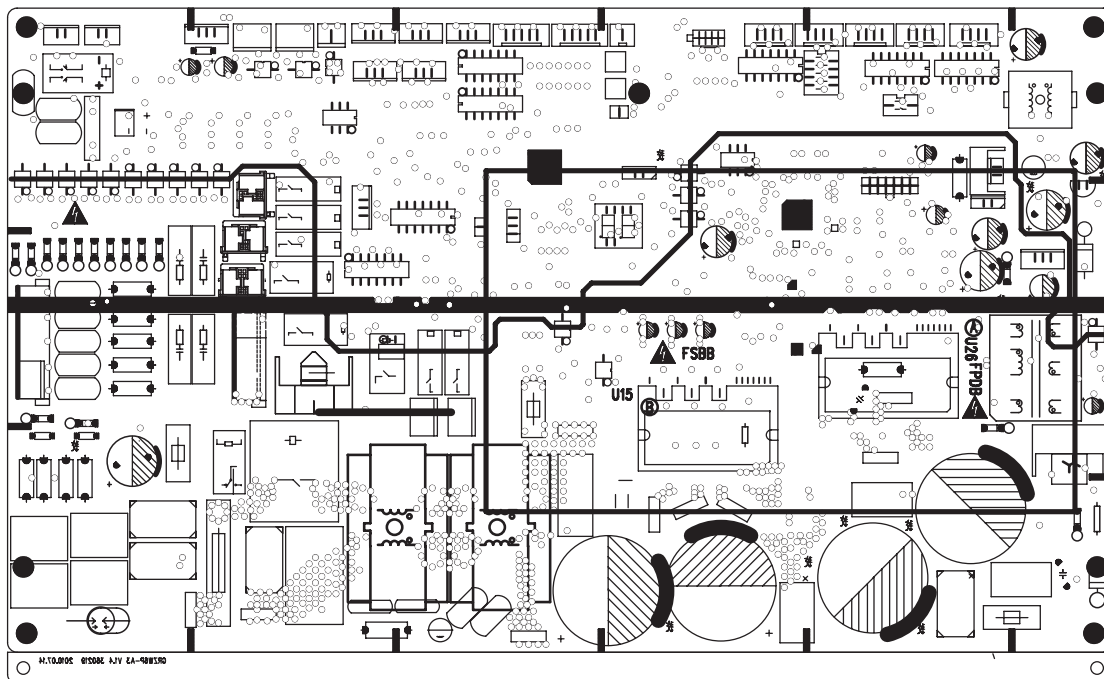

1	FA-FE: Terminals of EXV(Electronic expansion Valve)
2	JUMP2:the code of capacity
3	SA1: Master select switch
4	T-SENSOR2:Terminals of temperature sensor
5	TUBE-A - TUBE-E:Terminals of tube temperature sensor
6	OVC-COMP:Terminals of overload protector
7	LPP:Terminals of low pressure switch
8	HPP:Terminals of high pressure switch
9	4V1:Terminals of 4-way valve
10	COM:Terminals of communication
11	OFAN1:Terminals of fan
12	E1:Terminals of Earth
13	AC-L:Terminals of line wire
14	FUSE1: Fuse
15	N:Terminals of neutral wire
16	HEAT:Terminals of compressor band heater
17	L1-1:Terminals of reactor's brown wire
18	FUSE3: Fuse of fan
19	L2-2:Terminals of reactor's blue wire
20	U/V/W:Terminals of compressor
21	L1-2:Terminals of reactor's white wire
22	L2-1:Terminals of reactor's yellow wire

6. Description of Each Control Operation

(1) Models: 14K, 18K, 24K, 28K

1 Basic functions of the system

1.1 Cooling Mode

1.1.1 Cooling conditions and process:

If the compressor is in stop status and start the unit for cooling operation, when one of the indoor units reaches the cooling operation condition, the unit start cooling operation; in this case, the electronic expansion valve, the outdoor fan and the compressor start operation.

1.1.2 Stop in cooling operation

1.1.2.1 Compressor stops

The compressor stops immediately, the outdoor fan stops after 1min.

1.1.2.2 Some of the indoor units reach the stop condition (the compressor does not stop)

The compressor operates immediately according to the required frequency. For the indoor unit with no requirement, the corresponding electronic expansion valve is closed to OP.

1.1.3 Cooling mode transfers to heating mode

When the unit transfers to heating mode, the 4-way valve is energized after the compressor stops for 2min. The other disposals are the same as stopping in cooling mode.

1.1.4 4-way valve: in this mode, the 4-way valve is closed.

1.1.5 Outdoor fan control in cooling mode

The outdoor fan starts before 5s of the starting of compressor. The outdoor fan will run in high speed for 3min after starting and then it will run in set speed. The fan shall run at every speed for at least 80s. (When the quantity of running indoor unit is changed, the unit will enter the control described in 1.3.5.1 and 1.3.5.2);

When the compressor stops, the outdoor fan runs at present speed and stops after 1min.

1.2 Dry Mode

1.2.1 The dry conditions and process are the same as those in cooling mode;

1.2.2 The status of 4-way valve: closed;

1.2.3 The temperature setting range: 16 ~ 30 °C;

1.2.4 Protection function: the same as those in cooling mode;

1.2.5 In dry mode, the maximum value A of the capacity requirement percentage of single unit is 90% of that in cooling mode.

The open condition of the electronic expansion valve, outdoor fan and compressor is the same as those in cooling mode.

1.3 Heating Mode

1.3.1 Cooling conditions and process:

When one of the indoor units reaches the heating operation condition, the unit starts heating operation.

1.3.2 Stop in heating operation:

1.3.2.1 When all the indoor units reach the stop condition, the compressor stops and the outdoor fan stops after 1min;

1.3.2.2 Some of the indoor units reach the stop condition

The compressor reduces the frequency immediately and operates according to the required frequency;

1.3.2.3 Heating mode transfers to cooling mode(dry mode), fan mode

a. The compressor stops; b. the power of 4-way valve is cut off after 2min; c. the outdoor fan stops after 1min; d. the status of 4-way valve: energized;

1.3.3 Outdoor fan control in heating mode

The outdoor fan starts before 5s of the starting of compressor and then it will run in high speed for 40s;

The fan shall run at every speed for at least 80s;

When the compressor stops, the outdoor fan stops after 1min.

1.3.4 Defrosting function

When the defrosting condition is met, the compressor stops; the electronic expansion valve of all indoor units open in big angle; the outdoor fan stops after 40s of the stop of compressor, meanwhile, the 4-way valve reverses the direction; after the 4-way valve reverses the direction, the compressor starts; then begin to calculate the time of defrosting, the frequency of the compressor rises to reach the defrosting frequency.

1.3.5 Oil-returned control in heating mode

1.3.5.1 Oil-returned condition

The whole unit is operating in low frequency for a long time

1.3.5.2 Oil-returned process in heating mode

The indoor unit displays "H1"

1.3.5.3 Oil-returned finished condition in heating mode

The duration reaches 5min

1.4 Fan Mode

The compressor, the outdoor fan and the 4-way valve are closed; temperature setting range is 16~30℃.

2. Protection Function

2.1 Mode Conflict Protection of indoor unit

When the setting mode is different of different indoor unit, the unit runs in below status:

- a. The mode of the first operating indoor unit is the basic mode, then compare the mode of the other indoor units to see if there is a conflict. Cooling mode (dry mode) is in conflict with heating mode.
- b. Fan mode is in conflict with heating mode and the heating mode is the basic mode. No matter which indoor unit operates first, the unit will run in heating mode.

2.2 Overload protection function

When the tube temperature is a little low, the compressor raises the operation frequency; when the tube temperature is a little high, the compressor frequency is restricted or lows down the operation frequency; when the tube temperature is too high, the compressor protection stops running.

If the discharge temperature protection continuously appears for 6 times, the compressor can't resume running. The compressor can resume running after cutting off the power and then putting through the power. (if the running time of the compressor is longer than 7min, the protection times record will be cleared)

2.3 Discharge Protection Function

When the discharge temperature is a little low, the compressor raises the operation frequency; when the discharge temperature is a little high, the compressor frequency is restricted or lows down the operation frequency; when the discharge temperature is too high, the compressor protection stops running.

If the discharge temperature protection continuously appears for 6 times, the compressor can't resume running. The compressor can resume running after cutting off the power and then putting through the power. (if the running time of the compressor is longer than 7min, the protection times record will be cleared)

2.4 Communication malfunction

Detection of the quantity of installed indoor units:

After 3min of energizing, if the outdoor unit does not receive the communication data of certain indoor unit, the outdoor unit will judge that indoor unit is not installed and will treat it as it is not installed. If the outdoor unit receives the communication data of that indoor unit later, the outdoor unit will treat that unit as it is installed.

2.5 Overcurrent Protection

a. Overcurrent protection of complete unit; b. phase wire current protection; c. compressor phase current protection

2.6 Compressor high-pressure protection

2.6.1 When the high-pressure switch is detected cut off for 3s continuously, the compressor will enter high-pressure protection as it stops when reaching set temperature. Meanwhile, the outdoor unit will send the signal of "high-pressure protection" to the indoor units;

2.6.2 After the appearance of high-pressure protection, when the high-pressure switch is detected closed for 6s continuously, the compressor can resume running only after cutting off the power and then putting through the power.

2.7 Compressor overload protection

If the compressor overload switch is detected having movement, the indoor unit will display the corresponding malfunction as it stops when the indoor temperature reaching set temperature. When the compressor stops for more than 3min and the compressor overload switch is reset, the unit will resume operation status automatically. If the protection appears for more than 6 times (if the running time of the compressor is longer than 30min, the protection times record will be cleared), the unit can not resume operation status automatically, but can resume running only after cutting off the power and then putting through the power.

2.8 Compressor Phase-lacking Protection

When the compressor starts, if one of the three phases is detected open, the compressor will enter phase-lacking protection. The malfunction will be cleared after 1min, the unit will restart and then detect if there is still has phase-lacking protection. If the phase-lacking protection is detected for 6 times continuously, the compressor will not restart but can resume running only after cutting off the power and then putting through the power. If the running time of the compressor is longer than 7min, the protection times record will be cleared.

2.9 IPM Protection

2.9.1 When the IMP module protection is detected, the unit will stop as the indoor temperature reaching set temperature, PFC is closed, display IMP protection malfunction. After the compressor stops for 3min, the unit will resume operation status automatically; if the IMP protection is detected for more than 6 times continuously (If the running time of the compressor is longer than 7min, the protection times record will be cleared), the system will stop and send the signal of module protection to indoor unit. The unit can not resume operation status automatically, but can resume running only after cutting off the power and then putting through the power.

2.9.2 IMP module overheating protection

2.9.2.1 When $T_{IMP} > 85^{\circ}\text{C}$, prohibit to raise frequency;

2.9.2.2 When $T_{IMP} \geq 90^{\circ}\text{C}$, the operation frequency of compressor lows down by 15% every 90s according to the present capacity requirement of the complete unit. It will keep 90s after lowering down the frequency. After lowering down the frequency, if $T_{IMP} \geq 90^{\circ}\text{C}$, the unit will circulate the above movement until reaching the minimum frequency; if $85^{\circ}\text{C} < T_{IMP} < 90^{\circ}\text{C}$, the unit will run at this frequency; when $T_{IMP} \leq 85^{\circ}\text{C}$, the unit will run at the frequency according to the capacity requirement;

2.9.2.3 When $T_{IMP} \geq 95^{\circ}\text{C}$, the compressor stops. After the compressor stops for 3min, if $T_{IMP} < 85^{\circ}\text{C}$, the compressor and the outdoor fan will resume operation.

(2)Models:36K,42K

1.Control Function of Outdoor Unit

1.1 Cooling Mode

a. Cooling conditions and process:

If the compressor is in stop status and start the unit for cooling operation, when one of the indoor units reaches the cooling operation condition, the unit start cooling operation; in this case, the electronic expansion valve, the outdoor fan and the compressor start operation.

b. Stop in cooling operation

a) Compressor stops

The compressor stops gradually, the outdoor fan stops after 1min.

b) Some of the indoor units reach the stop condition (the compressor does not stop) The compressor operates according to the required frequency. For the indoor unit with no requirement, the corresponding electronic expansion valve is closed to 0P.

c. Cooling mode transfers to heating mode

When the unit transfers to heating mode, the 4-way valve is energized after the compressor runs for 40s. The other disposals are the same as stopping in cooling mode.

d. 4-way valve:

In this mode, the 4-way valve is closed.

e. Outdoor fan control in cooling mode

The outdoor fan starts before 5s of the starting of compressor. The outdoor fan will run in middle speed for 40s after starting and then it will run in set speed.

The fan shall run at every speed for at least 80s. (when indoor units quantity changes, the control part will adjust the outdoor fan according to the indoor units quantity and outdoor temperature.); When the compressor stops, the outdoor fan runs at present speed and stops after 1min.

1.2 Dry Mode

a. The dry conditions and process are the same as those in cooling mode;

b. The status of 4-way valve: closed;

c. The temperature setting range: 16 ~ 30 °C ;

d. Protection function: the same as those in cooling mode;

e. In dry mode, the maximum value A of the capacity requirement percentage of single unit is 90% of that in cooling mode. The open condition of the electronic expansion valve, outdoor fan and compressor is the same as those in cooling mode.

1.3 Heating Mode

a. Heating conditions and process: When one of the indoor units reaches the heating operation condition, the unit starts heating operation.

b. Stop in heating operation:

a) When all the indoor units reach the stop condition, the compressor stops and the outdoor fan stops after 1min;

b) Some of the indoor units reach the stop condition The compressor reduces the frequency immediately and operates according to the required frequency;

c) Heating mode transfers to cooling mode(dry mode), fan mode

The compressor stops;

The outdoor fan stops after 1min;

The status of 4-way valve: energized;

c. Outdoor fan control in heating mode

The outdoor fan starts before 5s of the starting of compressor and then it will run in middle speed for 40s; The fan shall run at every speed for at least 80s; When the compressor stops, the outdoor fan stops after 1min.

d. Defrosting function

When the defrosting condition is met, the frequency of the compressor starts to decrease and wait for defrosting; the electronic expansion valve of all indoor units open in big angle; the outdoor fan stops after the stop of the 4-way valve, meanwhile, the 4-way valve reverses the direction; after the 4-way valve reverses the direction, the frequency of the compressor starts to rise; then begin to calculate the time of defrosting, the frequency of the compressor rises to reach the defrosting frequency.

e. Oil-returned control in heating mode

a) Oil-returned condition

The whole unit is operating in low frequency for a long time

b) Oil-returned process in heating mode

The indoor unit displays "H1"

c) Oil-returned finished condition in heating mode

The duration reaches 5min

1.4 Fan Mode

The compressor, the outdoor fan and the 4-way valve are closed; temperature setting range is 16 ~30°C .

2. Protection Function

2.1 Mode Conflict Protection of indoor unit

When the setting mode is different of different indoor unit, the unit runs in below status:

- a. The mode of the first operating indoor unit is the basic mode, then compare the mode of the other indoor units to see if there is a conflict. Cooling mode (dry mode) is in conflict with heating mode.
- b. Fan mode is in conflict with heating mode and the heating mode is the basic mode. No matter which indoor unit operates first, the unit will run in heating mode.

2.2 Overload Protection Function

When the tube temperature is a little low, the compressor raises the operation frequency; when the tube temperature is a little high, the compressor frequency is restricted or lows down the operation frequency; when the tube temperature is too high, the compressor protection stops running. If the discharge temperature protection continuously appears for 6 times, the compressor can't resume running. The compressor can resume running after cutting off the power and then putting through the power. (if the running time of the compressor is longer than 7min, the protection times record will be cleared)

2.3 Discharge Protection Function

When the discharge temperature is a little low, the compressor raises the operation frequency; when the discharge temperature is a little high, the compressor frequency is restricted or lows down the operation frequency; when the discharge temperature is too high, the compressor protection stops running. If the discharge temperature protection continuously appears for 6 times, the compressor can't resume running. The compressor can resume running after cutting off the power and then putting through the power. (if the running time of the compressor is longer than 7min, the protection times record will be cleared)

2.4 Communication malfunction

Detection of the quantity of installed indoor units: After 3min of energizing, if the outdoor unit does not receive the communication data of certain indoor unit, the outdoor unit will judge that indoor unit is not installed and will treat it as it is not installed. If the outdoor unit receives the communication data of that indoor unit later, the outdoor unit will treat that unit as it is installed.

2.5 Compressor high-pressure protection

- a. When the high-pressure switch is detected cut off for 3s continuously, the compressor will enter high-pressure protection as it stops when reaching set temperature. Meanwhile, the outdoor unit will send the signal of "high-pressure protection" to the indoor units;
- b. After the appearance of high-pressure protection, the compressor can resume running only after cutting off the power and then putting through the power.

2.6 Compressor low-pressure protection

a. Low Pressure Protection for Shutdown

After the compressor stops for five minutes, if it is detected that the low pressure protection switch is opened, then a low pressure protection signal will be send out.

If it is detected continuously for three seconds that the low pressure protection switch is opened after the compressor stops for less than five minutes, then a low pressure protection signal will be send out. However, if the low pressure protection occurs twice in one hour, then it becomes unrecoverable and has to be recovered by powering the outdoor unit again.

b. Low Pressure Protection during the Operation

a) When it is detected continuously for three seconds that the low pressure protection switch is opened, then the whole unit should be shut off and a low pressure protection signal should be sent to the indoor unit.

b) On condition that a low pressure protection error occurs and the whole unit has stopped for more than three minutes and it is detected continuously for six seconds that the low pressure protection switch is closed, then this error can be eliminated. However, if the low pressure protection occurs twice in one hour, then it has to eliminate the error by powering the outdoor unit again.

2.7 Compressor overload protection

If the compressor overload switch is detected having movement, the indoor unit will display the corresponding malfunction as it stops when the indoor temperature reaching set temperature. When the compressor stops for more than 3min and the compressor overload switch is reset, the unit will resume operation status automatically. If the protection appears for more

than 6 times (if the running time of the compressor is longer than 30min, the protection times record will be cleared), the unit can not resume operation status automatically, but can resume running only after cutting off the power and then putting through the power.

3.other function

Refrigerant Recovery

The refrigerant can be recovered from either the indoor unit or the outdoor unit.

When the unit is powered on and runs under the COOL mode, it is available within five minute to go the refrigerant recovery mode by pressing three times the "LIGHT" button on the wireless controller in three seconds with "Fo" displayed.

How to quit the refrigerant recovery:

When the refrigerant recovery has started, it will quit when there is a signal from the wireless controller or it has run for ten minutes.

7. Installation Manual

7.1 Electrical Connections

(1)GWHD(14)NK3BO,GWHD(18)NK3DO,GWHD(24)NK3DO:

1. Remove the handle at the right side plate of the outdoor unit (one screw).
2. Remove the cable clamp, connect the power connection cable with the terminal at the row of connection and fix the connection. The fitting line distributing must be consistent with the indoor unit. terminal of line bank. Wiring should meet that of indoor unit.
3. Fix power connection wire by wire clamp.
4. Ensure wire has been fixed well.
5. Install the handle.

! An all-pole disconnection switch having a contact separation of at least 3mm in all pole should be connected in fixed wiring.

! Wrong wire connection may cause malfunction of some electric components. After fixing cable, ensure that leads between connection to fixed point have some space.

! The connection pipes and the connecting wirings of the unit A and unit B must be corresponding to each other respective.

! The appliance shall be installed in accordance with national wiring regulations.

Note: the above figures are only intended to be a simple diagram of the appliance and may not correspond to the appearance of the units that have been purchased.

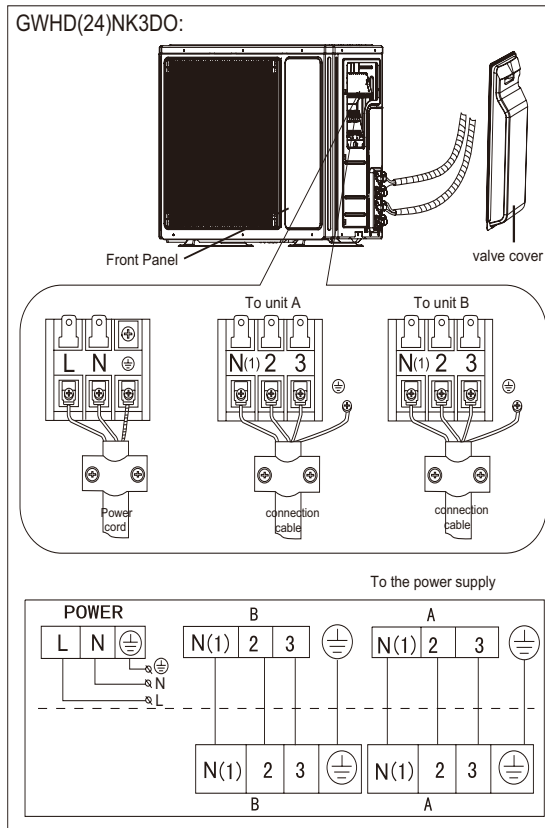
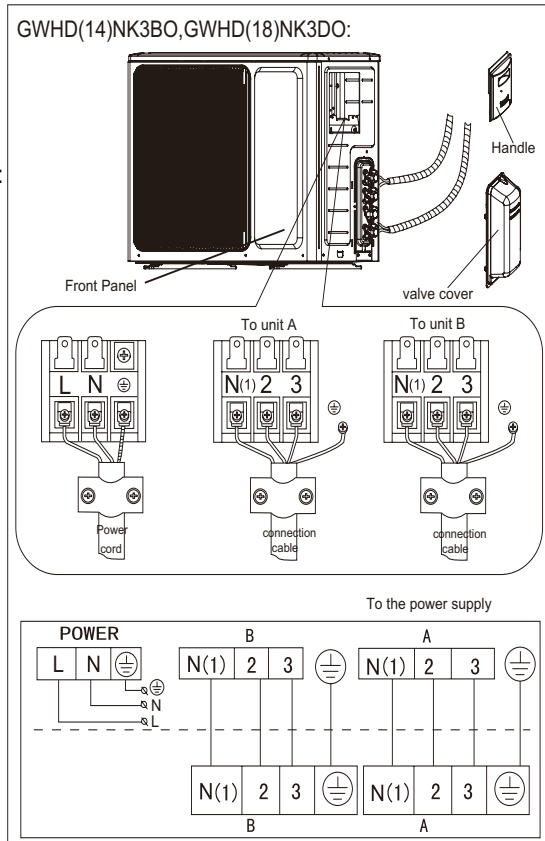

(2) GWHD(24)NK3EO:

1. Remove the valve cover at the right side plate of the outdoor unit (one screw).
2. Remove the cable clamp, connect the power connection cable with the terminal at the row of connection and fix the connection. The fitting line distributing must be consistent with the indoor unit. terminal of line bank. Wiring should meet that of indoor unit.
3. Fix power connection wire by wire clamp.
4. Ensure wire has been fixed well.
5. Install the valve cover.



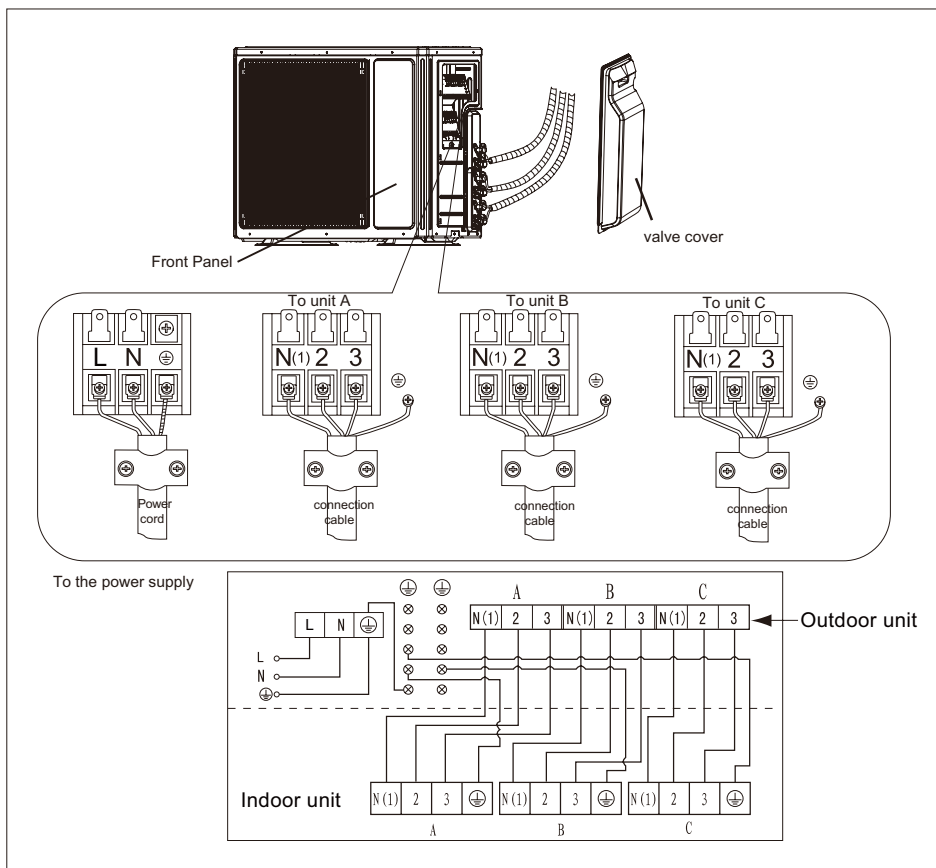

- ⚠ An all-pole disconnection switch having a contact separation of at least 3mm in all pole should be connected in fixed wiring.
- ⚠ Wrong wire connection may cause malfunction of some electric components. After fixing cable, ensure that leads between connection to fixed point have some space.
- ⚠ The connection pipes and the connecting wirings of the unit A ,unit B and unit C must be corresponding to each other respective.
- ⚠ The appliance shall be installed in accordance with national wiring regulations.
- ⚠ Do not install the outdoor unit where it is exposed to the sunlight.

Note: the above figures are only intended to be a simple diagram of the appliance and may not correspond to the appearance of the units that have been purchased.



(3) GWHD(28)NK3BO:

1. Remove the valve cover at the right side plate of the outdoor unit (one screw).
2. Remove the cable clamp, connect the power connection cable with the terminal at the row of connection and fix the connection. The fitting line distributing must be consistent with the indoor unit. terminal of line bank.
Wiring should meet that of indoor unit.
3. Fix power connection wire by wire clamp.
4. Ensure wire has been fixed well.
5. Install the valve cover.

-  An all-pole disconnection switch having a contact separation of at least 3mm in all pole should be connected in fixed wiring.
-  Wrong wire connection may cause malfunction of some electric components. After fixing cable, ensure that leads between connection to fixed point have some space.
-  The connection pipes and the connecting wirings of the unit A ,unit B,unit C and unit D must be corresponding to each other respective.
-  The appliance shall be installed in accordance with national wiring regulations.
-  Do not install the outdoor unit where it is exposed to the sunlight.

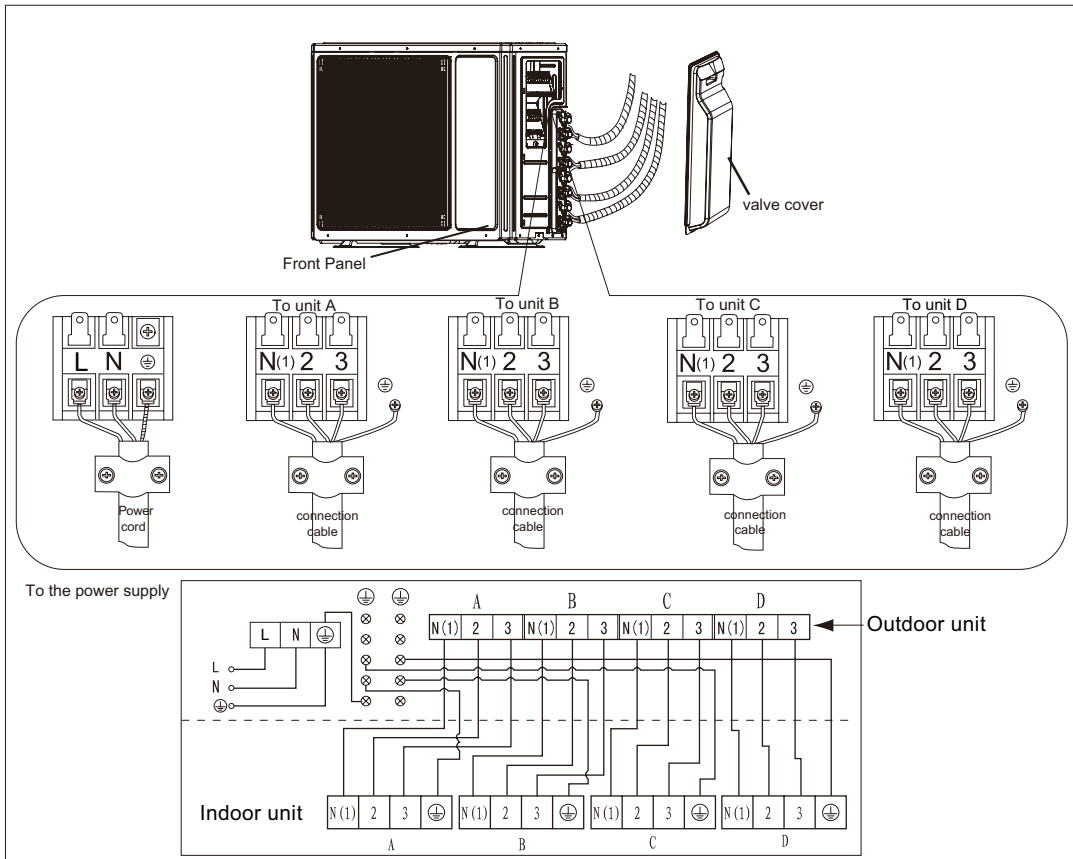

-  After having removed the packaging, check that the contents are intact and complete.
-  Handling must be done by suitably equipped qualified technical personnel using equipment that is suitable for the weight of the appliance.
-  The outdoor unit must always be kept upright.

7.2 Installing the Outdoor Unit

! Use bolts to secure the unit to a flat, solid floor. When mounting the unit on a wall or the roof, make sure the support is firmly secured so that it cannot move in the event of intense vibrations or a strong wind.

Do not install the outdoor unit in pits or air vents
Installing the pipes

! Use suitable connecting pipes and equipment for the refrigerant R410A.

Models(m)	14/18K	GWHD(24)NK3DO	24/28K
Max. connection pipe length	20	20	70
Max. connection pipe length(Simple one indoor unit)	10	10	20

!

! The refrigerant pipes must not exceed the maximum heights 10m.

! Wrap all the refrigerant pipes and joints.

! Tighten the connections using two wrenches working in opposite directions.

Caution: Installation Must be Performed in Accordance with the NEC/CEC by Authorized Personnel Only.

Humid air left inside the refrigerant circuit can cause compressor malfunction. After having connected the indoor and outdoor units, bleed the air and humidity from the refrigerant circuit using a vacuum pump.

1. Unscrew and remove the caps from the 2-way and 3-way valves.
2. Unscrew and remove the cap from the service valve.
3. Connect the vacuum pump hose to the service valve.
4. Operate the vacuum pump for 10-15 minutes until an absolute vacuum of 10 mm Hg has been reached.
5. With the vacuum pump still in operation, close the low-pressure knob on the vacuum pump coupling. Stop the vacuum pump.
6. Open the 2-way valve by 1/4 turn and then close it after 10 seconds. Check all the joints for leaks using liquid soap or an electronic leak device.
7. Turn the body of the 2-way and 3-way valves. Disconnect the vacuum pump hose.
8. Replace and tighten all the caps on the valves.

Diameter (mm)	Twisting moment (N.m)
Φ6	15-20
Φ9.52	35-40
Φ16	60-65
Φ12	45-50
Φ19	70-75

18K unit need to be installed the indoor unit

18K Model:

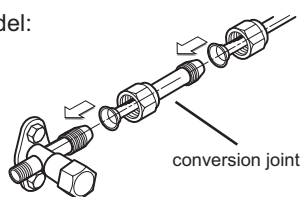

Install the drain fitting and the drain hose(for model with heat pump only)

Condensation is produced and flows from the outdoor unit when the appliance is operating in the heating mode. In order not to disturb neighbours and to respect the environment, install a drain fitting and a drain hose to channel the condensate water. Install the drain fitting and rubber washer on the outdoor unit chassis and connect a drain hose to it as shown in the figure.

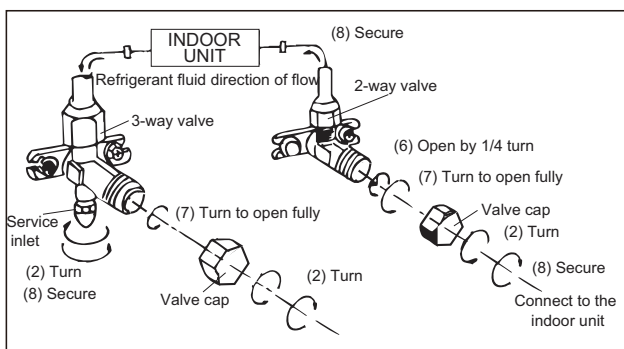
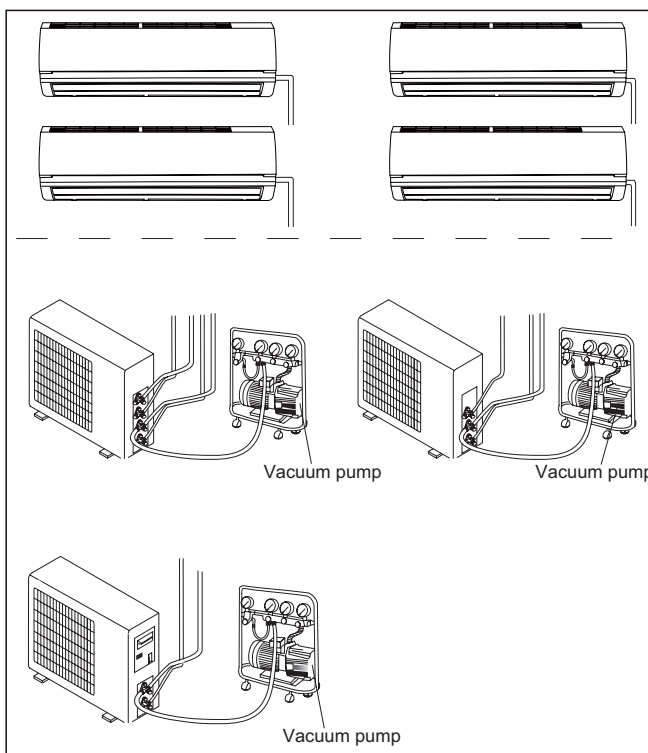
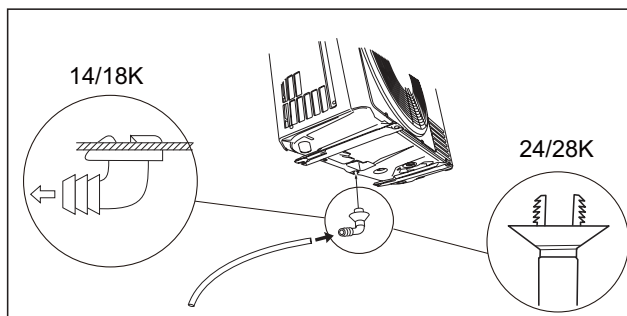

7.3 Installation Dimension Diagram

- ⚠ Use suitable instruments for the refrigerant R410A.
- ⚠ Do not use any other refrigerant than R410A.
- ⚠ Do not use mineral oils to clean the unit.
- ⚠ The installation must be done by trained and qualified service personnel with reliability according to this manual.
- ⚠ Contact service center before installation to avoid the malfunction due to unprofessional installation.
- ⚠ When picking up and moving the units, you must be guided by trained and qualified person.
- ⚠ Ensure that the recommended space is left around the appliance.

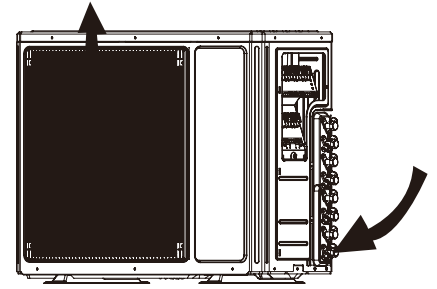

GWHD(14)NK3BO, GWHD(18)NK3DO

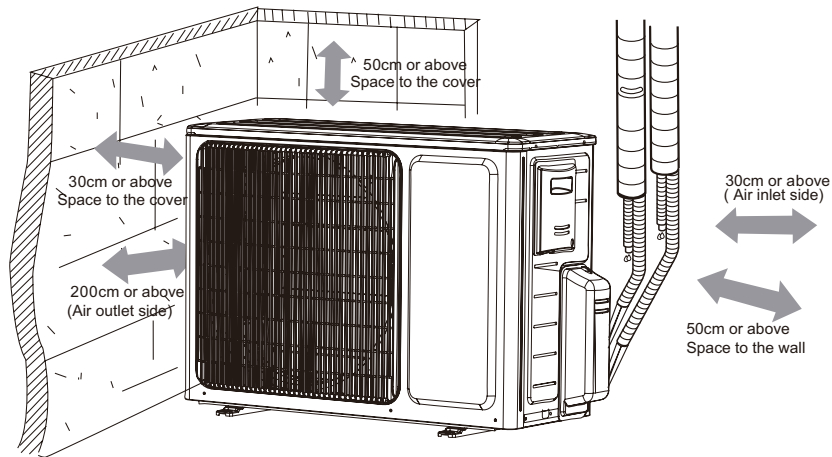

GWHD(24)NK3DO, GWHD(24)NK3EO, GWHD(28)NK3BO

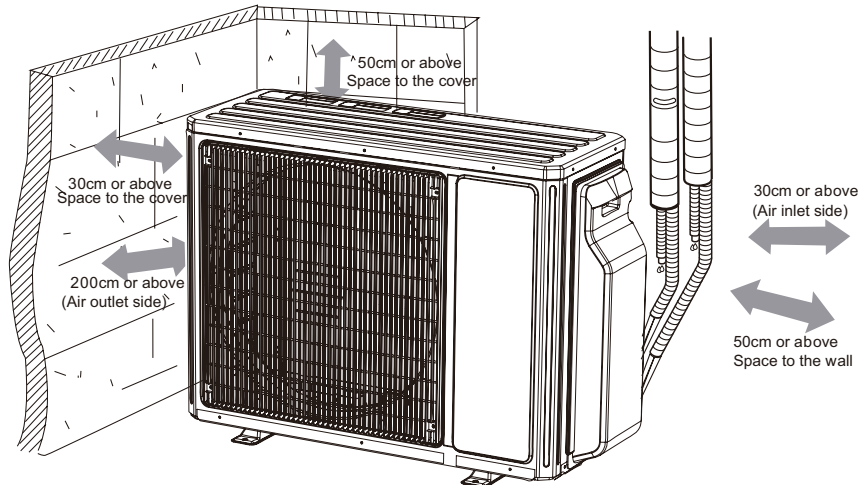

This is just the schematic plan, please refer to the actual product.

7.4 Check after Installation

Check Items	Problems Owing to Improper Installation
Is the installation reliable?	The unit may drop, vibrate or make noises
Has the gas leakage been checked?	May cause unsatisfactory cooling (heating) effect
Is the thermal insulation of the unit sufficient?	May cause condensation and water dropping
Is the drainage smooth?	May cause condensation and water dropping
Does the power supply voltage accord with the rated voltage specified on the nameplate?	The unit may bread down or the components may be burned out
Are the lines and pipelines correctly installed?	The unit may bread down or the components may be burned out
Has the unit been safely grounded?	Risk of electrical leakage
Are the models of lines in conformity with requirements?	The unit may bread down or the components may be burned out
Are there any obstacles near the air inlet and outlet of the indoor and outdoor units?	The unit may bread down or the components may be burned out
Have the length of refrigerating pipe and refrigerant charge amount been recorded?	It is not easy to decide the charge amount of refrigerant.

7.5 Models:36K and 42K

Safety Precautions

Please read this manual carefully before using and operating correctly as instructed in this manual.

Please especially take notice of the following two symbols:

⚠ Warning! It indicates improper operation which will lead to human casualty or severe injury.

⚠ Caution! It indicates improper operation which will lead to injury or property damage.

⚠ Warning!

◆ The installation should be committed to the appointed service center; otherwise it will cause water leakage, electric shock or fire etc.

◆ Please install the unit in a place where is strong enough to withstand the weight of the unit; otherwise, the unit would fall down and cause injury or death.

◆ The drain pipe should be installed as instructed in the manual to guarantee the proper drainage; meanwhile it should be insulated to prevent condensing; otherwise the improper installation would cause water leakage and then wet the household wares in the room.

◆ Do not use or place any inflammable or explosive substance near the unit.

◆ Under the occurrence of an error (like burning smell etc.), please cut off the main power supply of the unit.

◆ Keep good ventilation in the room to avoid oxygen deficit.

◆ Never insert your finger or any other object into the air outlet/inlet grille.

◆ Please take notice of the supporting frame of the unit to see if it is damaged over the long time period of use.

◆ Never refit the unit and contact the sales agent or the professional installation personnel for the repair or relocation of the unit.

◆ Non-professional personnel are prohibited to dismantle the electric box owing to the high voltage of the outdoor unit.

An all-pole disconnection switch having a contact separation of at least 3mm in all poles should be connected in fixed wiring.

⚠ Caution!

◆ Before installation, please check if the power supply corresponds with the requirement specified on the nameplate and also check its security.

◆ Before using the unit, please check if the piping and wiring are correct to avoid water leakage, refrigerant leakage, electric shock, or fire etc.

◆ The main power supply must be earthed to avoid the hazard of electric shock and never connect this earth wire to the gas pipe, running water pipe, lightning rod or phone cable's earth lead.

◆ Turn off the unit after it runs at least five minutes; otherwise its service life will be shortened.

◆ Do not allow children operate this unit.

◆ Do not operate this unit with wet hands.

◆ Cut off the main power supply prior to the cleaning of the unit or the replacement of the air filter.

◆ When the unit is not to be used for a long time, please cut off the main power supply of the unit.

◆ Do not expose the unit to the moist or corrosive circumstances.

◆ Never step on the unit or place any object on it.

◆ It is suggested to have a power-on test annually.

7.5.1 Installation Location and Matters Needing Attention

The installation of the unit must comply with the national and local safety regulations. The installation quality directly affects the normal use, so the user should not carry out the installation personally, instead, the installation and debugging should be done by technician according to this manual. Only after that, can the unit be energized.

- a. How to select the installation location for the indoor unit
 - 1) Where there is no direct sunlight.
 - 2) Where the top hanger, ceiling and the building structure are strong enough to withstand the weight of the unit.
 - 3) Where the drain pipe can be easily connected to outside.
 - 4) Where the flow of the air inlet/outlet is not blocked.
 - 5) Where the refrigerant pipe of the indoor unit can be easily led to outside.
 - 6) Where there is no inflammable, explosive substances or their leakage.
 - 7) Where there is no corrosive gas, heavy dust, salt mist, smog or moisture.
- b. How to select the installation location for the outdoor unit
 - 1) The outdoor unit must be installed where the bearing surface is stable and secure enough.
 - 2) The outdoor unit and indoor unit should be placed as close as possible to minimize the length and bends of the refrigerant pipe.
 - 3) Do not install the outdoor unit under the window or between the buildings to prevent the normal running noise entering the room.
 - 4) Where the flow of the air inlet/outlet is not blocked.
 - 5) The outdoor unit should be installed where ventilation is in good condition so that the unit can take in and discharge enough air.
 - 6) Do not install the unit where there are inflammable and explosive substances and where there is heavy dust, salt fog and other severely polluted air.

No air guiding pipe is allowed to be installed at the air inlet/outlet of the outdoor unit. Under the heating mode, the condensate water would drip down from the base frame and would be frozen when the outdoor ambient temperature is lower than 0°C (32 °F) . Besides, the installation of the outdoor unit should not affect the heat radiation of the unit.

⚠CAUTION!

The unit installed in the following places is likely to run abnormally. If unavoidable, please contact the professional personnel at the GREE appointed service center. ① where is full of oil; ② alkaline soil off the sea; ③ where there is sulfur gas (like sulfur hot spring) ; ④ where there are devices with high frequency (like wireless devices, electric welding devices, or medical equipments); ⑤ special circumstances.

- c. Electric Wiring
 - 1) The installation must be done in accordance with the national wiring regulations.
 - 2) Only the power cord with the rated voltage and exclusive circuit for the air conditioning can be used.
 - 3) Do not pull the power cord by force.
 - 4) The electric installation should be carried out by the professional personnel as instructed by the local laws, regulations and also this manual.
 - 5) The diameter of the power cord should be large enough and once it is damaged it must be replaced by the dedicated one.
 - 6) The earthing should be reliable and the earth wire should be connected to the dedicated device of the building by the professional personnel. Besides, the air switch coupled with the leakage current protection switch must be equipped, which is of enough capacity and of both magnetic and thermal tripping functions in case of the short circuit and overload.

Table 1

Models	Power Supply	Capacity of the Air Switch	Recommended Cord (pieces× sectional area)
GWHD(36)NK3AO	220-240V~ 50Hz	32A	6mm ² ×3
GWHD(42)NK3AO	220-240V~ 50Hz	32A	6mm ² ×3

d. Earthing Requirements

- 1) The air conditioner is classified into the Class I appliances, so its earthing must be reliable.
- 2) The yellow-green line of the air conditioner is the earth line and can not be used for other purpose, cut off or fixed by the tapping screw; otherwise it would cause the hazard of electric shock.
- 3) The reliable earth terminal should be provided and the earth wire can not be connected to any of the following places.
 - ① Running water pipe;
 - ② Coal gas pipe;
 - ③ Sewage pipe;
 - ④ Other places where the professional personnel think unreliable.

GWHD(36)NK3AO

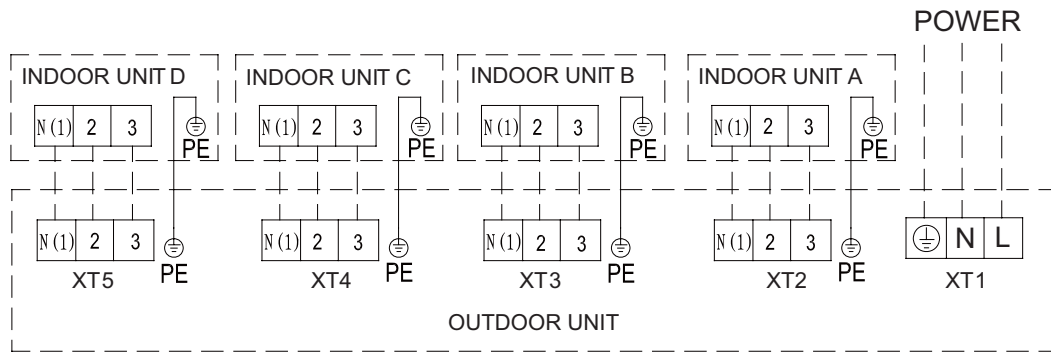

Fig.1

GWHD(42)NK3AO

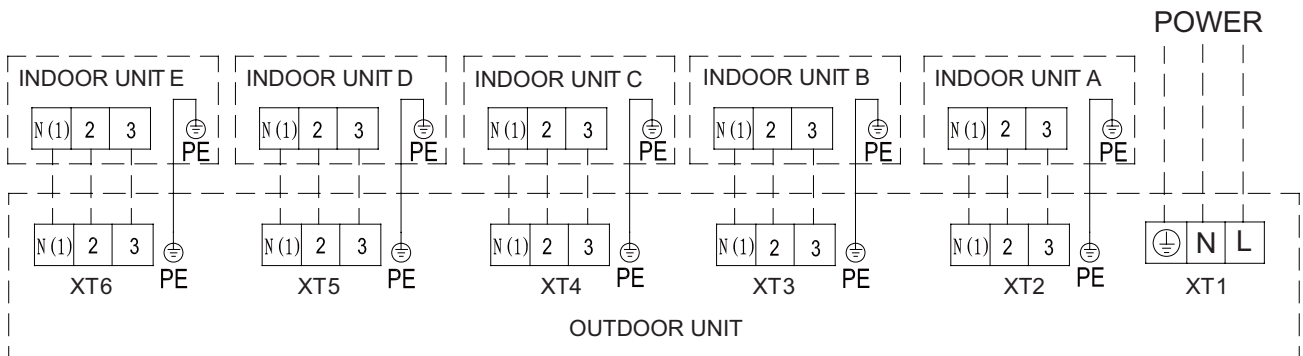

Fig.2

a. Noise Precautions

- 1) The air conditioning unit should be installed where ventilation is in good condition, otherwise the working capability of the unit would be reduced or working noise would be increased.
- 2) The air conditioning unit should be installed on the base frame which is stable and secure uncouth to withstand the weight of the unit; otherwise it would incur vibration and noise.
- 3) During the installation, a consideration should be taken that the produced hot air or noise should not affect neighbors or surroundings.
- 4) Do not stack obstacles near the air outlet of the outdoor unit; otherwise it would reduce the working capability of the unit or increase the working noise.
- 5) In the event of the occurrence of abnormal noise, please contact the sales agent as soon as possible.

b. Accessories for Installation

Refer to the packing list for the accessories of the indoor and outdoor units respectively.

7.5.2 Installation of the Outdoor Unit

a. Precautions for the Installation of the Outdoor Unit

The following rules should be followed when the installation location is being considered so as to let the unit run well enough.

- 1) The discharged air from the outdoor unit won't return back and enough space should be left for maintenance around the unit.
- 2) The installation location should be in good condition so that the unit is able to take in and discharge enough air. Besides, make sure there is no obstacle at the air inlet/outlet of the unit. If there is, remove it.
- 3) The unit must be installed where it is secure enough to support the weight of the unit and capable of reducing to some extent noise and vibration to make sure they do not bother your neighbors.
- 4) The designated lifting hole must be used for lifting the unit and protect the unit carefully during lifting to prevent damaging the metal sheet which would result in rusting in future.
- 5) The unit should be installed where there is as little as direct sunlight.
- 6) The unit must be installed where the rain water and defrosting water can be drained.
- 7) The unit must be installed where the unit won't be covered by the snow and won't be affected by rubbish and oil fog.
- 8) Rubber or spring shock absorbers should be used during the installation of the outdoor unit to meet the noise and vibration requirements.
- 9) The installation dimensions should meet the requirement covered in this manual and the outdoor unit must be fixed securely.
- 10) The installation should be carried out by the professionally skilled personnel.

b. Installation of the Outdoor Unit

- 1) Outline dimension of the outdoor unit.

GWHD(36)NK3AO

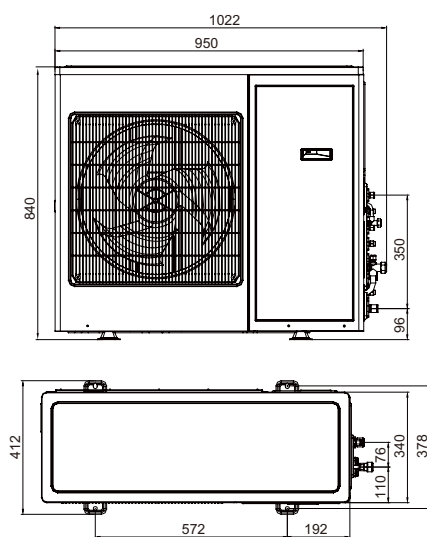

Fig.3

GWHD(42)NK3AO

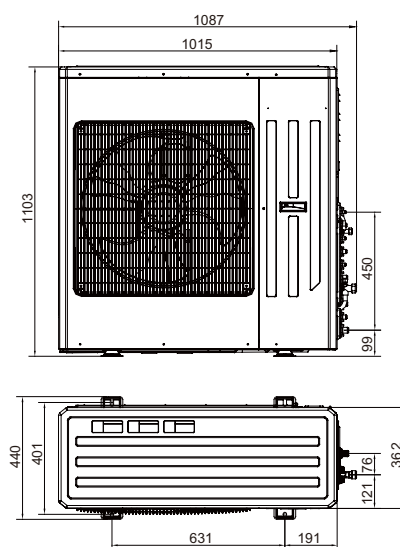

Fig.4

- 2) During the transportation of the outdoor unit, two lifting ropes long enough must be used in four directions and the included angle must be less than 40° prevent the center of unit deviating.
- 3) During the installation, M12 screws should be used to fix the support leg and base frame of the unit.
- 4) The unit should be installed on a concrete base frame with a height of 10cm.
- 5) The installation space of the unit should be as required in Fig.5.

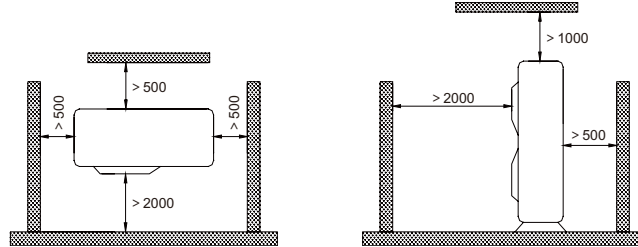

Fig.5

7.5.3 Connection between Indoor and Outdoor Units

a. Wiring of the Power Cord

⚠CAUTION!

A breaker must be installed, capable of cutting off the power supply for the whole system.

- 1) Open the side plate.
- 2) Let the power cord go through the rubber ring.
- 3) Connect the power card to the terminals “L”, “N” and also the earthing bolt, and then connect the wiring terminals “N(1),2,3” of the indoor unit to those of the outdoor unit correspondingly.
- 4) Fix the power cord with wire clips.

b. Energy Level and Capacity Code of the Indoor and Outdoor Units

Table 2

	Energy Level	Capacity Code
Indoor Unit	09	25
	12	35
	18	50
	21	60
	24	71
Outdoor Unit	36	100
	42	120

- 1) The outdoor unit with energy level 36 can drive up to four sets of indoor units, while the outdoor unit 42 can drive up to five.
- 2) The sum of the capacity codes of the indoor units should be among 50%-150% of that of the outdoor unit.

c. Allowable Length and Height Fall of the Refrigerant Pipe

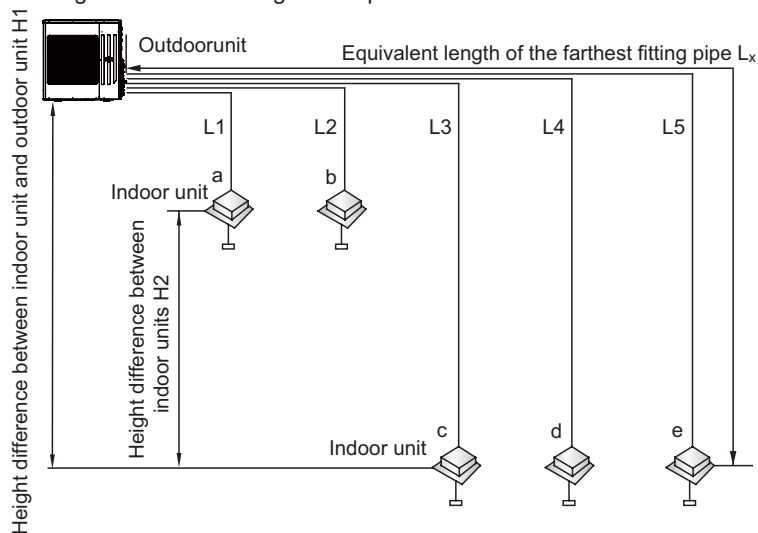

Table 3

		Allowable Length		Refrigerant Pipe	
		36	42	36	42
Total Length(m)		70	80	$L_1+L_2+L_3+L_4$	$L_1+L_2+L_3+L_4+L_5$
Max. Length for Single Unit(m)		20	25	L_x	
Max. installation altitude	Outdoor unit and indoor unit	15	15	H1	
	Indoor unit and indoor unit	7.5	7.5	H2	

Table 4: Dimension of the Refrigerant Pipe of the Indoor Unit unit: mm

Capacity Level of the Indoor Unit	Gas Pipe	Liquid Pipe
09,12	Φ9.52	Φ6.35
18	Φ12.7	Φ6.35
21,24	Φ15.9	Φ9.52

d.Piping between the Indoor and Outdoor Units

- 1) Refer to Fig.6 for the moments of torque for tightening screws.
- 2) Let the flare end of the copper pipe point at the screw and then tighten the screw by hand.
- 3) After that, tighten the screw by the torque wrench unit it clatters (as shown in Fig.6).
- 4) The bending degree of the pipe can not be too small; otherwise it will crack. And please use a pipe tube bender to bend the pipe.
- 5) Wrap the exposed refrigerant pipe and the joints by sponge and then tighten them with the plastic tape.

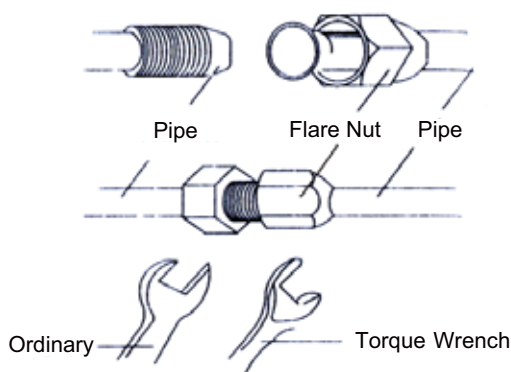
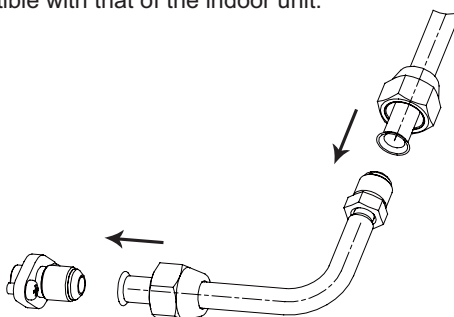

Fig.6

Table 5: Moments of Torque for Tightening Screws

Diameter	Wall Thickness (mm)	Moment of Torque
Φ6.35mm	≥0.5	15-30(N·m)
Φ9.52mm	≥0.71	30-40(N·m)
Φ12.7mm	≥1	45-50(N·m)
Φ15.9mm	≥1	60-65(N·m)

If the specification of the outdoor unit pipe joint does not conform to that of the indoor unit, then the joint specification of the outlet pipe of the indoor unit takes precedence. A reducing nipple shall be installed at the joint of the outdoor unit so as to make the joint of the outdoor unit compatible with that of the indoor unit.



⚠CAUTION!

① During the connection of the indoor unit and the refrigerant pipe, never pull any joints of the indoor unit by force; otherwise the capillary pipe or other pipe may crack, which then would result in leakage.

② The refrigerant pipe should be supported by brackets, that is, don't let the unit withstand the weight of it.

⚠CAUTION!

For the Free match system, each pipe should be labeled to tell which system it belongs to avoid mistaken inaccurate piping.

e. Installation of the Protection Layer of the Refrigerant Pipe

1) The refrigerant pipe should be insulated by the insulating material and plastic tape in order to prevent condensation and water leakage.

2) The joints of the indoor unit should be wrapped with the insulating material and no gap is allowed on the joint of the indoor unit, as shown in Fig.7.

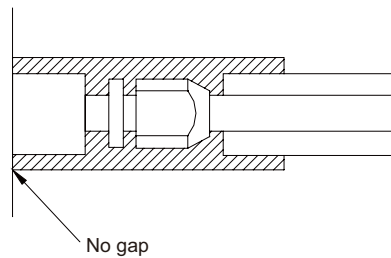

Fig.7

⚠CAUTION!

After the pipe is protected well enough, never bend it to form a small angle; otherwise it would crack or break.

f. Wrapping the Pipe with Tape

1) Bundle the refrigerant pipe and electric wire together with tape, and separate them from the drain pipe to prevent the condensate water overflowing.

2) Wrap the pipe from the bottom of the outdoor unit to the top of the pipe where it enters the wall. During the wrapping, the later circle should cover half of the former one.

3) Fix the wrapped pipe on the wall with clamps.

⚠CAUTION!

① Do not wrap the pipe too tightly; otherwise the insulation effect would be weakened. Additionally, make sure the drain hose is separated from the pipe.

② After that, fill the hole on the wall with sealing material to prevent wind and rain coming into the room.

7.5.4 Refrigerant Charging and Trial Running

a. Refrigerant Charging

1) The refrigerant has been charged into the outdoor unit before shipment, while additional refrigerant still need be charged into the refrigerant pipe during the field installation.

2) Check if the liquid valve and the gas valve of the outdoor unit are closed fully.

3) As shown in the following figure (Fig.8), expel the gas inside the indoor unit and refrigerant pipe out by the vacuum pump.

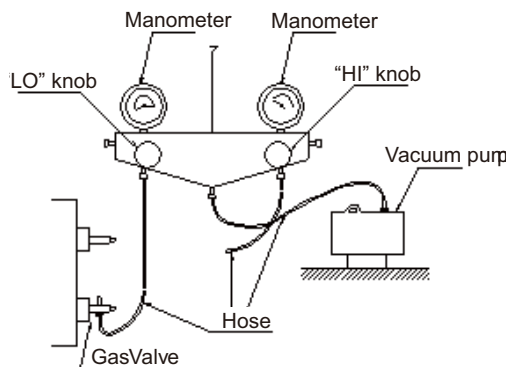

Fig.8

4) When the compressor is not running, charge the R410A refrigerant into the refrigerant pipe from the liquid valve of the outdoor unit (do not do it from the gas valve).

a. Calculation of the Additional Refrigerant Charging

1) Refrigerant Charge in the Outdoor Unit before Shipment

Table 6

Model	GWHD(36)NK3AO	GWHD(42)NK3AO
Refrigerant Charge (kg)	3.6	4.8

Notes:

① The refrigerant charge mentioned in the table above is not included those charged additionally in the indoor unit and the refrigerant pipe.

② The amount of the additional refrigerant charge is dependent on the diameter and length of the liquid refrigerant pipe which is decided by the actual yield installation requirement.

③ Record the additional refrigerant charge for future maintenance.

2) Calculation of the Additional Refrigerant Charge

If the total refrigerant pipe length (liquid pipe) is smaller than that listed in the table below, no additional refrigerant will be charged.

Table 7

Model	Total Liquid Pipe Length (a+b+c+d+e)
GWHD(36)NK3AO	≤40m
GWHD(42)NK3AO	≤50m

Additional Refrigerant Charge₂=ΣExtra Liquid Pipe Length×22g/m(liquid pipe 1/4").

Note: if the total refrigerant pipe length is larger than that listed in the table above, the additional refrigerant for the extra length of the pipe needs to be charged as per 22g/m.

3) Example : GWHD (42) NK3AO

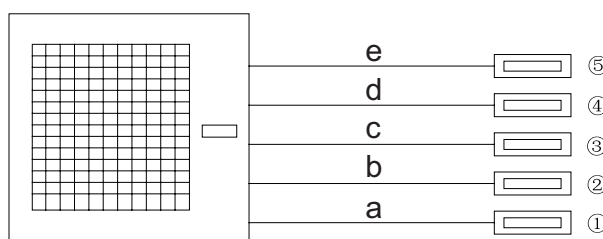

Fig.9

Table 8 Indoor Unit

Serial No.	Model
Indoor Unit ⑤	Ducted Type GFH(09)EA-K3DNA1A/I
Indoor Unit ④	Ducted Type GFH(09)EA-K3DNA1A/I
Indoor Unit ③	Ducted Type GFH(09)EA-K3DNA1A/I
Indoor Unit ②	Ducted Type GFH(09)EA-K3DNA1A/I
Indoor Unit	Ducted Type GFH(18)EA-K3DNA1A/I

Table 9 Liquid Refrigerant Pipe

Serial No.	e	d	c	b	a
Diameter	Φ6.35	Φ6.35	Φ6.35	Φ6.35	Φ9.52
Length	20m	20m	15m	5m	5m

The total length of each liquid refrigerant pipe is: e+d+c+b+a=20+20+15+5+5=65m. Thus, the minimum additional refrigerant charge=(65-50)×0.022=0.33kg (Note: no additional refrigerant is needed for the liquid pipe within 50m).

4) Additional Refrigerant Charge Record

Table 10 Indoor Unit

No.	Indoor Unit Model	Additional Refrigerant Charge(kg)
1		
2		
.....		
N		
Total		

Table 11 Refrigerant Pipe

Diameter	Total Length(m)	Additional Refrigerant Charge(kg)
Φ15.9		
Φ12.7		
Φ9.52		
Φ6.35		
Total		

c. Items to be checked after the Installation

Table 12

Items to be Checked	Possible Errors	Check Results
Has each part and component of the unit been installed securely?	The unit may fall off, vibrate or generate noise.	
Has the gas leakage test been taken?	The cooling (heating) capacity may be poor.	
Is the thermal insulation sufficient?	Dews and water drops may be generated.	
Does the drainage go well?	Dews and water drops may be generated.	
Is the actual power voltage in line with the value marked on the nameplate?	The unit may break down or some components may be burnt out.	
Are the wiring and the piping correct?	The unit may break down or some components may be burnt out.	
Has the unit been earthed reliably?	There may be a danger of electric shock.	
Does the wire meet the regulated requirement?	The unit may break down or the component may be burnt out.	
Is there any obstacle at the air inlet/outlet of the indoor/outdoor unit?	The cooling (heating) capacity may be poor	
Have the length of the refrigerant pipe and the refrigerant charge been recorded?	It may be hard to know the exact refrigerant charge.	

d. Trial Running

1) Check before the Trial Running

- ① Check if the appearance of the unit and the piping system are damaged during the transportation.
- ② Check if the wiring terminals of the electronic component are secure.
- ③ Check if the rotation direction of the fan motor is right.
- ④ Check if all valves in the system are fully opened.

2) Trial Running

- ① The trial running should be carried out by the professionally skilled personnel on the premise that all items listed above are in normal conditions.
- ② Let the unit energized and switch the wired controller or the remoter controller to "ON".
- ③ The fan motor and compressor of the outdoor unit will run automatically in one minute.
- ④ If there is some unusual sound after the compressor is started, turn off the unit for an immediate check.

8. Exploded Views and Parts List

(1) Models:GWHD(14)NK3BO,GWHD(18)NK3DO

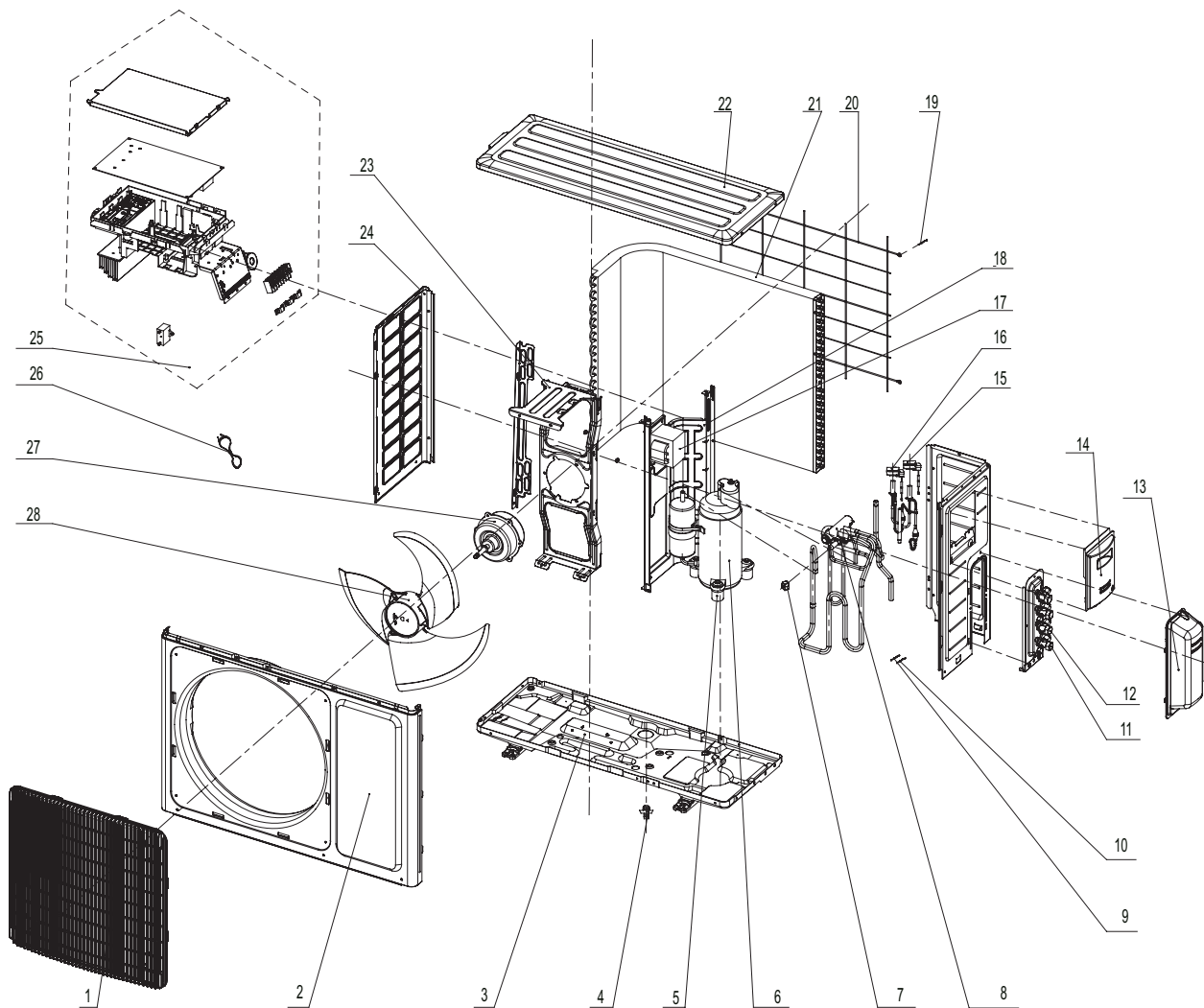

NO.	Description	Part Code		Qty
		GWHD(14)NK3BO	GWHD(18)NK3DO	
		Product Code	Product Code	
1	Front Grill	22413015	22413015	1
2	Cabinet	01433034P	01433034P	1
3	Chassis Sub-assy	01205161P	01205161P	1
4	Drainage Joint	26113009	26113009	1
5	Compressor Gasket	76710236	76710236	3
6	Compressor and fittings	00103501	00103501	1
7	Magnet Coil	4300040033	4300040033	1
8	4-way Valve Assy	03123438	03123438	1
9	Temperature Sensor	3900007301	3900007301	1
10	Temperature Sensor	39000073	39000073	1
11	Cut-off Valve	071302391	071302391	2
12	Cut-off Valve	07130239	07130239	2
13	Valve cover	22242101	22242101	1
14	Big Handle	26233048	26233048	1
15	Electric expand valve fitting	4300008401	4300008401	1
16	Electric expand valve fitting	43000084	43000084	1
17	PFC induction	43120130	43120130	1
18	Clapboard Sub-Assy	01233117	01233117	1
19	Temperature Sensor	3900030901	3900030901	1
20	Rear Grill	01475019	01475019	1
21	Condenser Assy	01113763	01113763	1
22	Top Cover	01253034P	01253034P	1
23	Motor Support Sub-Assy	01703398	01703398	1
24	Left Side Plate	01303169P	01303169P	1
25	Electric Box Assy	02603411	02603411	1
26	Connecting Cable	40020318	40020318	1
27	Fan Motor	15013162	15013162	1
28	Axial Flow Fan	10333010	10333010	1

The data above are subject to change without notice.

NO.	Description	Part Code		Qty
		GWHD(14)NK3BO	GWHD(18)NK3DO	
		Product Code	Product Code	
1	Front Grill	22413015	22413015	1
2	Cabinet	01433034P	01433034P	1
3	Chassis Sub-assy	01205168P	01205168P	1
4	Drainage Joint	26113009	26113009	1
5	Rubber Grommet	76815215	76815215	3
6	Compressor and fittings	00205262	00205262	1
7	Magnet Coil	4300040033	4300040033	1
8	4-Way Valve Assy	04144312	04144312	1
9	Temperature Sensor	3900007301	3900007301	1
10	Temperature Sensor	39000073	39000073	1
11	Cut off Valve	071302391	071302391	1
12	Cut off Valve	07130239	07130239	1
13	Valve Cover	22242101	22242101	1
14	Big Handle	26233048	26233048	1
15	Electric Expand Valve Fitting	4300008401	4300008401	1
16	Electric Expand Valve Fitting	43000084	43000084	1
17	PFC Inductance	43120130	43120130	1
18	Clapboard Sub-Assy	01233117	01233117	1
19	Temperature Sensor	3900030901	3900030901	1
20	Rear Grill	01475019	01475019	1
21	Condenser Assy	01124309	01124309	1
22	Top Cover	01253034P	01253034P	1
23	Motor Support Sub-Assy	01703398	01703398	1
24	Left Side Plate	01303169P	01303169P	1
25	Electric Box Assy	0260341103	0260341103	1
26	Connecting Cable	40020318	40020318	1
27	Fan Motor	15013162	15013162	1
28	Axial Flow Fan	10333016	10333016	1

The data above are subject to change without notice.

(2) Model:GWHD(24)NK3DO(CB228W0070)

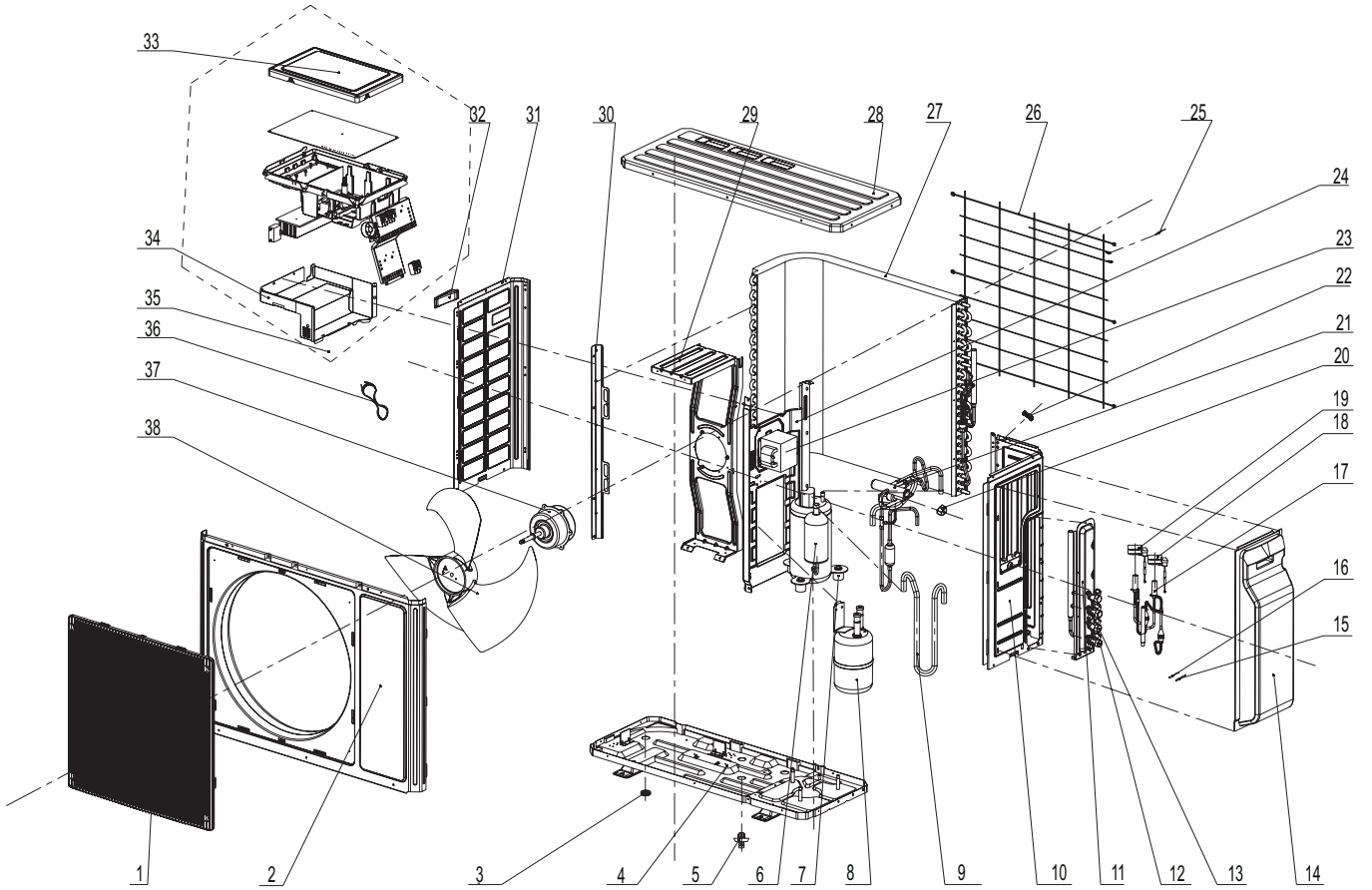

NO.	Description	Part Code	Qty
		GWHD(24)NK3DO	
		Product Code	
		CB228W0070	
1	Front grill	22415002	1
2	Front Panel	01535008P	1
3	Drainage Plug	06813401	3
4	Chassis Sub-assy	01203942P	1
5	Drainage Connector	06123401	1
6	Compressor and fittings	00105036	1
7	Compressor Gasket	76710207	3
8	Gas-liquid Separator Assy	07225017	1
9	Inhalation Tube	03723455	1
10	Right Side Plate	01303194P	1
11	Valve Support Sub-Assy	0171312802P	1
12	Cut-off Valve	07130239	2
13	Cut-off Valve	071302391	2
14	Valve cover	20123029	1
15	Temperature Sensor	3900007301	1
16	Temperature Sensor	39000073	1
17	Electronic Expansion Valve assy	07133457	1
18	Electric expand valve fitting	4300008401	1
19	Electric expand valve fitting	43000084	1
20	Magnet Coil	4300040033	1
21	4-way Valve Assy	03123415	1
22	Wiring clamp	26115004	1
23	PFC induction	43120129	1
24	Clapboard assy	01233116	1
25	Temperature Sensor	3900030901	1
26	Rear Grill	01473043	1
27	Condenser Assy	01113710	1
28	Top Cover	01255005P	1
29	Motor Support Sub-Assy	0170512001	1
30	Condenser support plate	01173415	1
31	Left Side Plate	01305041P	1
32	left handle	26235401	1
33	Insulated board (cover of electric box)	20113003	1
34	Electric box (fireproofing)	01413148	1
35	Electric Box Assy	0260337202	1
36	Connecting Cable	400205405	1
37	Fan Motor	1501506303	1
38	Axial Flow Fan	10335008	1

The data above are subject to change without notice.

(3) Model:GWHD(24)NK3DO(CB228W0071)

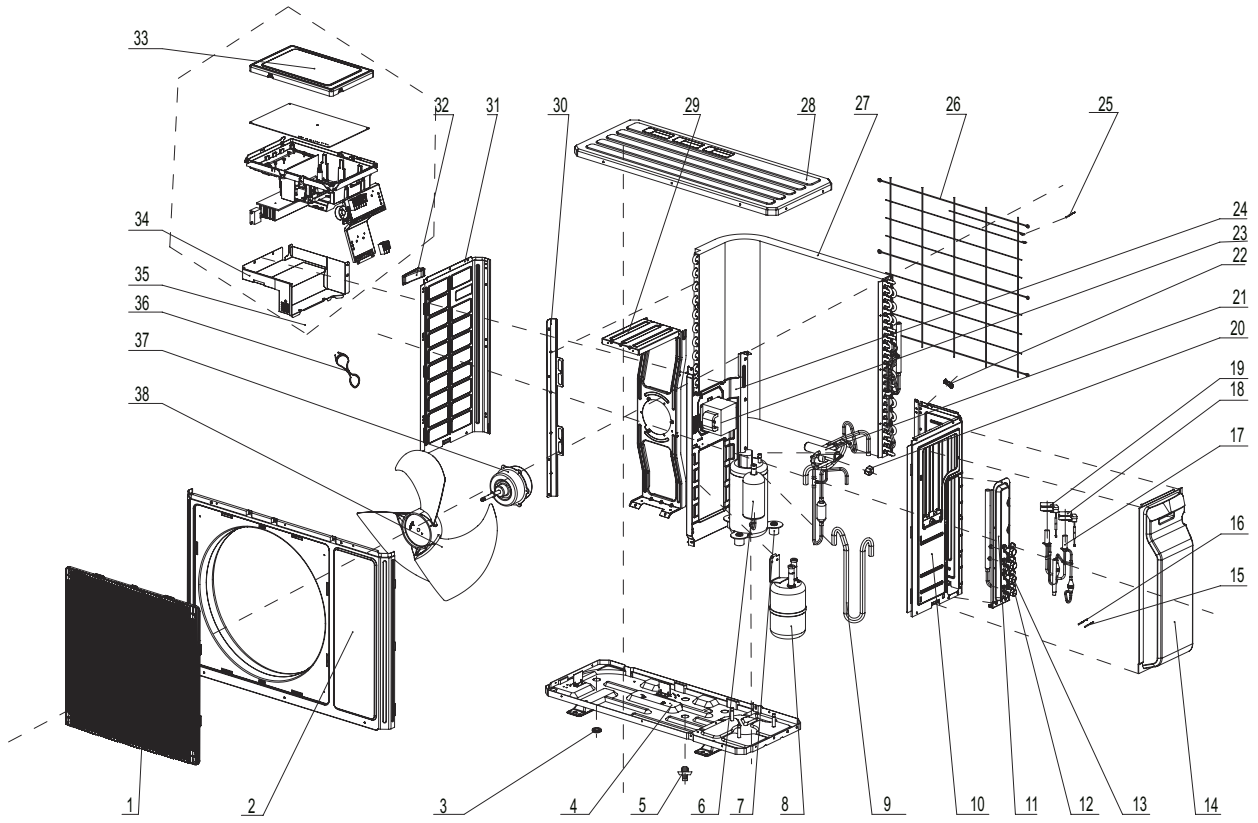

NO.	Description	Part Code	
		GWHD(24)NK3DO	
		CB228W0071	
			Qty
1	Front grill	22415002	1
2	Front Panel	01535008P	1
3	Drainage Plug	06813401	3
4	Chassis Sub-assy	01203942P	1
5	Drainage Connector	06123401	1
6	Compressor and fittings	00105036	1
7	Compressor Gasket	76710207	3
8	Gas-liquid Separator Assy	07225017	1
9	Inhalation Tube	03723455	1
10	Right Side Plate	01303194P	1
11	Valve Support Sub-Assy	0171312802P	1
12	Cut-off Valve	07130239	2
13	Cut-off Valve	071302391	2
14	Valve cover	20123029	1
15	Temperature Sensor	3900007301	1
16	Temperature Sensor	39000073	1
17	Electronic Expansion Valve assy	07133457	1
18	Electric expand valve fitting	4300008401	1
19	Electric expand valve fitting	43000084	1
20	Magnet Coil	4300040033	1
21	4-way Valve Assy	03123415	1
22	Wiring clamp	26115004	1
23	PFC induction	43120129	1
24	Clapboard assy	01233116	1
25	Temperature Sensor	3900030901	1
26	Rear Grill	01473043	1
27	Condenser Assy	01113710	1
28	Top Cover	01255005P	1
29	Motor Support Sub-Assy	0170512001	1
30	Condenser support plate	01173415	1
31	Left Side Plate	01305041P	1
32	left handle	26235401	1
33	Insulated board (cover of electric box)	20113003	1
34	Electric box (fireproofing)	01413148	1
35	Electric Box Assy	02603785	1
36	Connecting Cable	400205405	0
37	Fan Motor	1501506303	1
38	Axial Flow Fan	10335008	1

The data above are subject to change without notice.

(4) Model:GWHD(24)NK3EO(CB228W0100)

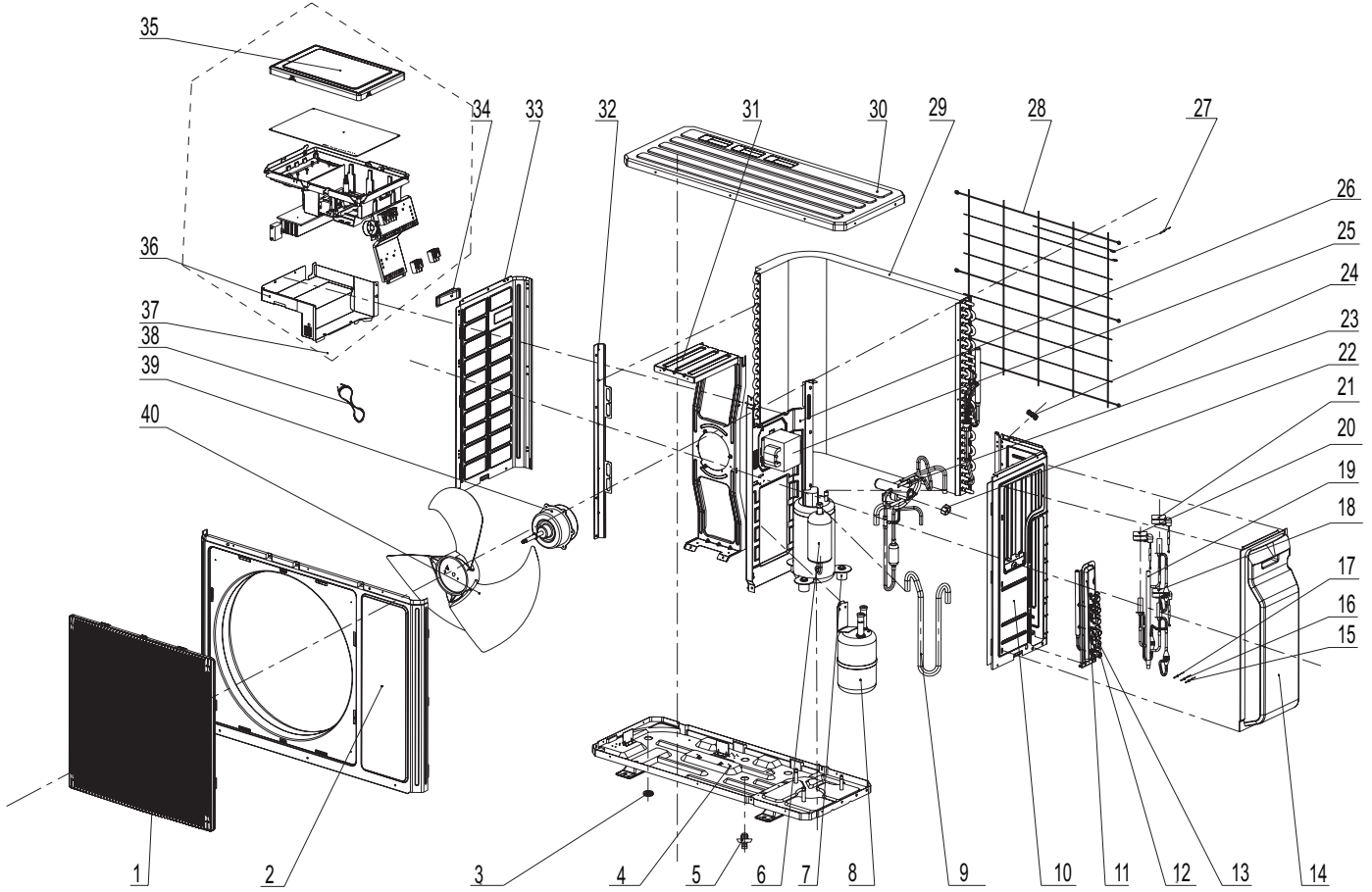

NO.	Description	Part Code	Qty
		GWHD(24)NK3EO	
		Product Code	
		CB228W0100	
1	Front grill	22415002	1
2	Front Panel	01535008P	1
3	Drainage Plug	06813401	3
4	Chassis Sub-assy	01203942P	1
5	Drainage Connector	06123401	1
6	Compressor and fittings	00105036	1
7	Compressor Gasket	76710207	3
8	Gas-liquid Separator Assy	07225017	1
9	Inhalation Tube	03723455	1
10	Right Side Plate	01303194P	1
11	Valve support assy	0710306601	1
12	Cut-off Valve	071302391	3
13	Cut-off Valve	07130239	3
14	Valve cover	20123029	1
15	Temperature Sensor	3900007302	1
16	Temperature Sensor	3900007301	1
17	Temperature Sensor	39000073	1
18	Electric expand valve fitting	4300008402	1
19	Electronic Expansion Valve assy	07133456	1
20	Electric expand valve fitting	43000084	1
21	Electric expand valve fitting	43000084	1
22	Magnet Coil	4300040033	1
23	4-way Valve Assy	03123415	1
24	Wiring clamp	26115004	1
25	PFC induction	43120129	1
26	Clapboard assy	01233116	1
27	Temperature Sensor	3900030901	1
28	Rear Grill	01473043	1
29	Condenser Assy	01113710	1
30	Top Cover	01255005P	1
31	Motor Support Sub-Assy	0170512001	1
32	Condenser support plate	01173415	1
33	Left Side Plate	01305041P	1
34	left handle	26235401	1
35	Insulated board (cover of electric box)	20113003	1
36	Electric box (fireproofing)	01413148	1
37	Electric Box Assy	0260337201	1
38	Connecting Cable	400205405	1
39	Fan Motor	1501506303	1
40	Axial Flow Fan	10335008	1

The data above are subject to change without notice.

(5) Model:GWHD(24)NK3EO(CB228W0101)

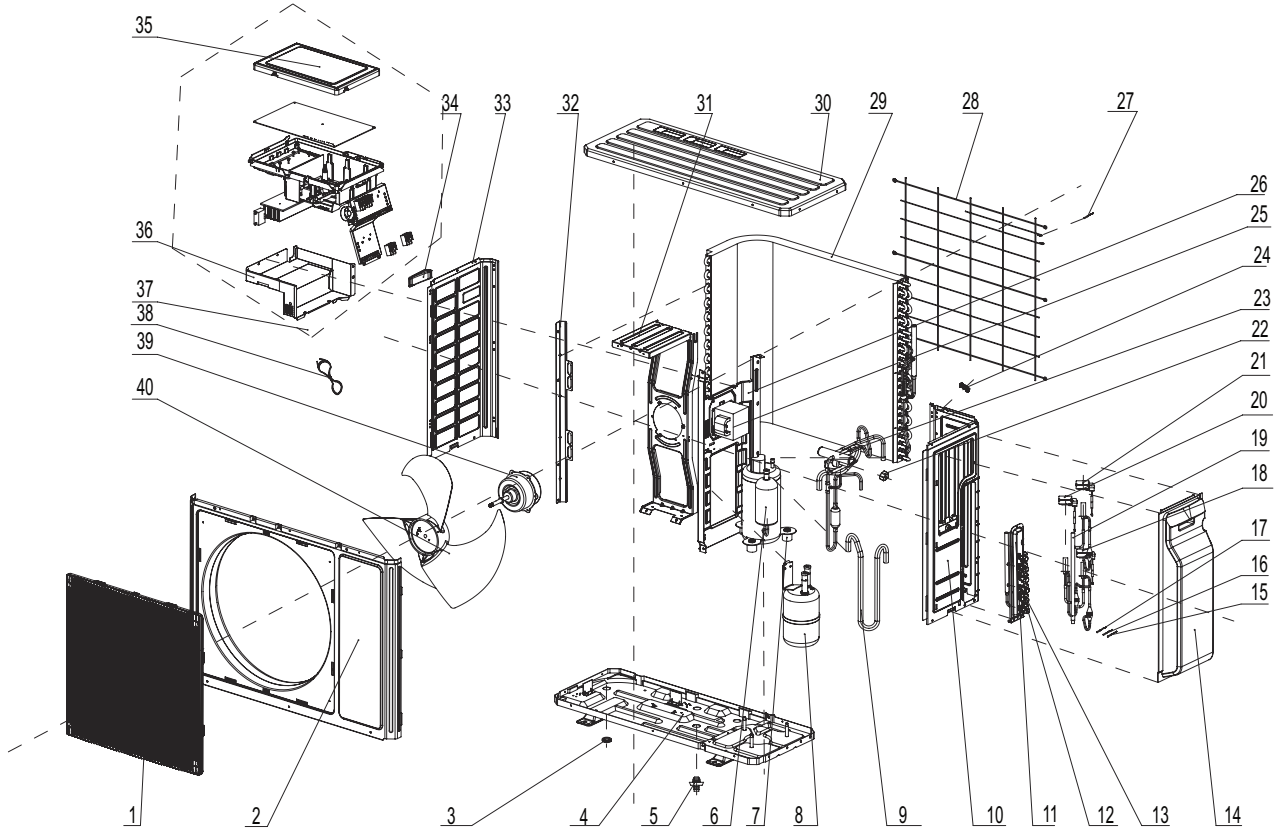

NO.	Description	Part Code	Qty
		GWHD(24)NK3EO	
		Product code	
		CB228W0101	
1	Front grill	22415002	1
2	Front Panel	01535008P	1
3	Drainage Plug	06813401	3
4	Chassis Sub-assy	01203942P	1
5	Drainage Connector	06123401	1
6	Compressor and fittings	00105036	1
7	Compressor Gasket	76710207	3
8	Gas-liquid Separator Assy	07225017	1
9	Inhalation Tube	03723455	1
10	Right Side Plate	01303194P	1
11	Valve support assy	0710306601	1
12	Cut-off Valve	071302391	3
13	Cut-off Valve	07130239	3
14	Valve cover	20123029	1
15	Temperature Sensor	3900007302	1
16	Temperature Sensor	3900007301	1
17	Temperature Sensor	39000073	1
18	Electric expand valve fitting	4300008402	1
19	Electronic Expansion Valve assy	07133456	1
20	Electric expand valve fitting	43000084	1
21	Electric expand valve fitting	43000084	1
22	Magnet Coil	4300040033	1
23	4-way Valve Assy	03123415	1
24	Wiring clamp	26115004	1
25	PFC induction	43120129	1
26	Clapboard assy	01233116	1
27	Temperature Sensor	3900030901	1
28	Rear Grill	01473043	1
29	Condenser Assy	01113710	1
30	Top Cover	01255005P	1
31	Motor Support Sub-Assy	0170512001	1
32	Condenser support plate	01173415	1
33	Left Side Plate	01305041P	1
34	left handle	26235401	1
35	Insulated board (cover of electric box)	20113003	1
36	Electric box (fireproofing)	01413148	1
37	Electric Box Assy	02603786	1
38	Connecting Cable	400205405	0
39	Fan Motor	1501506303	1
40	Axial Flow Fan	10335008	1

The data above are subject to change without notice.

(6) Model:GWHD(28)NK3BO(CB228W0110)

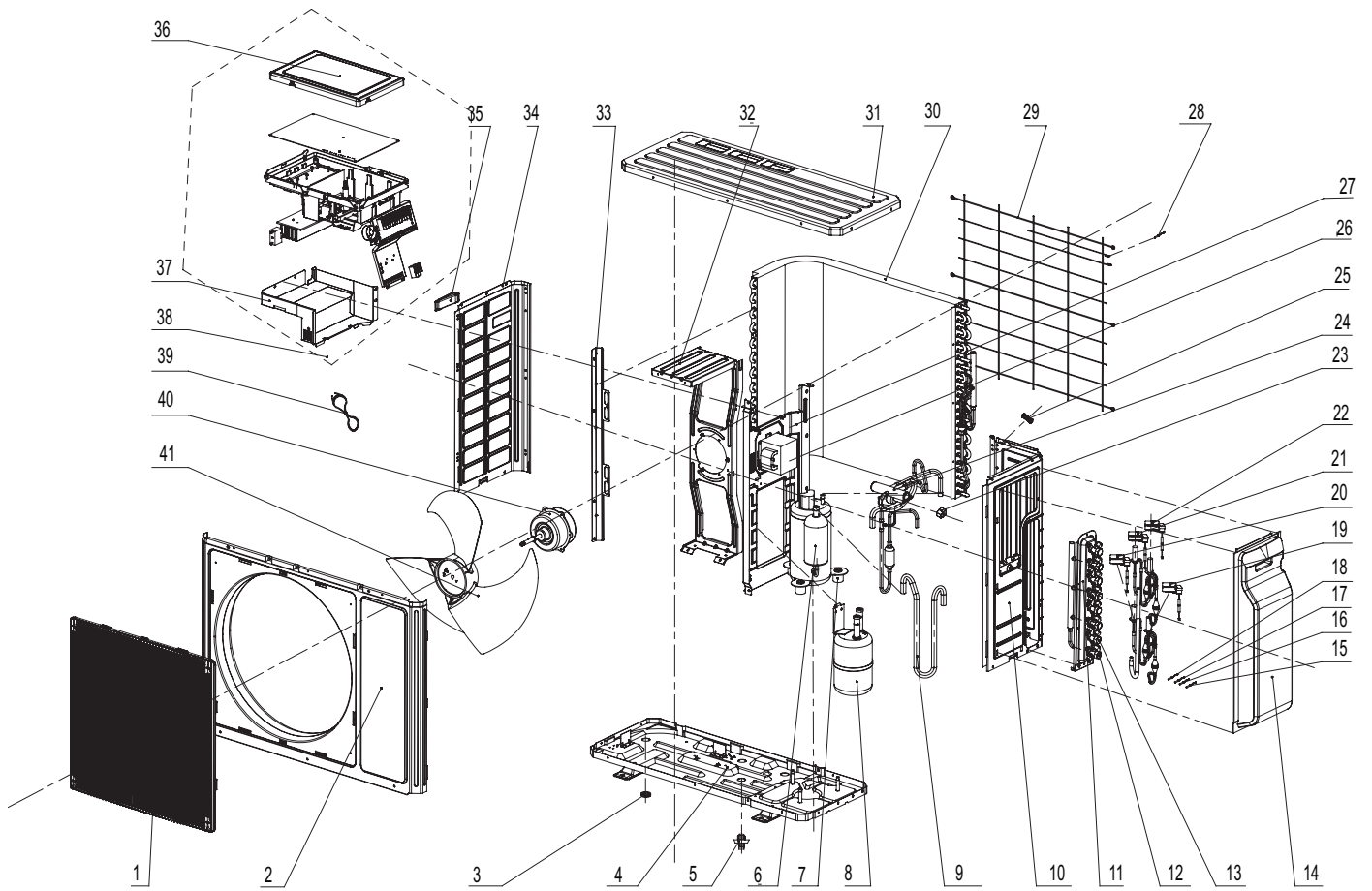

NO.	Description	Part Code	Qty
		GWHD(28)NK3BO	
		Product Code	
		CB228W0110	
1	Front grill	22415002	1
2	Front Panel	01535008P	1
3	Drainage Plug	06813401	3
4	Chassis Sub-assy	01203942P	1
5	Drainage Connector	06123401	1
6	Compressor and fittings	00105036	1
7	Compressor Gasket	76710207	1
8	Gas-liquid Separator Assy	07225017	1
9	Inhalation Tube	03723455	1
10	Right Side Plate	01303194P	1
11	Valve support assy	07103066	1
12	Cut-off Valve	071302391	4
13	Cut-off Valve	07130239	4
14	Valve cover	20123029	1
15	Temperature Sensor	3900007303	1
16	Temperature Sensor	3900007302	1
17	Temperature Sensor	3900007301	1
18	Temperature Sensor	39000073	1
19	Electric expand valve fitting	4300008403	1
20	Electric expand valve fitting	4300008402	1
21	Electric expand valve fitting	4300008401	1
22	Electric expand valve fitting	43000084	1
23	Magnet Coil	4300040033	1
24	4-way Valve Assy	03123415	1
25	Wiring clamp	26115004	1
26	PFC induction	43120129	1
27	Clapboard assy	01233116	1
28	Temperature Sensor	3900030901	1
29	Rear Grill	01473043	1
30	Condenser Assy	01113710	1
31	Top Cover	01255005P	1
32	Motor Support Sub-Assy	0170512001	1
33	Condenser support plate	01173415	1
34	Left Side Plate	01305041P	1
35	left handle	26235401	1
36	Insulated board (cover of electric box)	20113003	1
37	Electric box (fireproofing)	01413148	1
38	Electric Box Assy	02603372	1
39	Connecting Cable	400205405	1
40	Fan Motor	1501506303	1
41	Axial Flow Fan	10335008	1

The data above are subject to change without notice.

(7) Model:GWHD(28)NK3BO(CB228W0111)

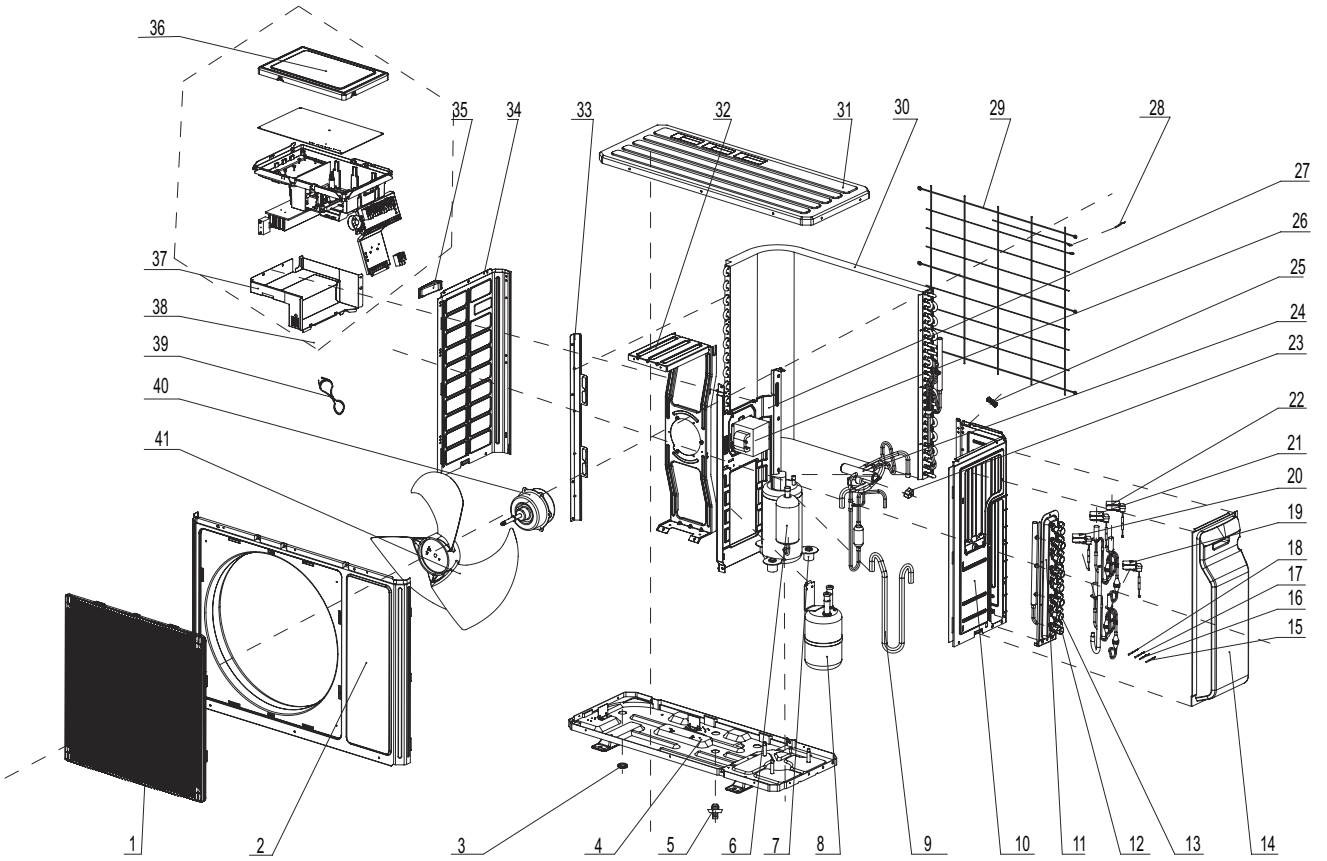

NO.	Description	Part Code		Qty
		GWHD(28)NK3BO		
		CB228W0111		
1	Front grill	22415002	1	
2	Front Panel	01535008P	1	
3	Drainage Plug	06813401	3	
4	Chassis Sub-assy	01203942P	1	
5	Drainage Connector	06123401	1	
6	Compressor and fittings	00105036	1	
7	Compressor Gasket	76710207	1	
8	Gas-liquid Separator Assy	07225017	1	
9	Inhalation Tube	03723455	1	
10	Right Side Plate	01303194P	1	
11	Valve support assy	07103066	1	
12	Cut-off Valve	071302391	4	
13	Cut-off Valve	07130239	4	
14	Valve cover	20123029	1	
15	Temperature Sensor	3900007303	1	
16	Temperature Sensor	3900007302	1	
17	Temperature Sensor	3900007301	1	
18	Temperature Sensor	39000073	1	
19	Electric expand valve fitting	4300008403	1	
20	Electric expand valve fitting	4300008402	1	
21	Electric expand valve fitting	4300008401	1	
22	Electric expand valve fitting	43000084	1	
23	Magnet Coil	4300040033	1	
24	4-way Valve Assy	03123415	1	
25	Wiring clamp	26115004	1	
26	PFC induction	43120129	1	
27	Clapboard assy	01233116	1	
28	Temperature Sensor	3900030901	1	
29	Rear Grill	01473043	1	
30	Condenser Assy	01113710	1	
31	Top Cover	01255005P	1	
32	Motor Support Sub-Assy	0170512001	1	
33	Condenser support plate	01173415	1	
34	Left Side Plate	01305041P	1	
35	left handle	26235401	1	
36	Insulated board (cover of electric box)	20113003	1	
37	Electric box (fireproofing)	01413148	1	
38	Electric Box Assy	02603750	1	
39	Connecting Cable	400205405	0	
40	Fan Motor	1501506303	1	
41	Axial Flow Fan	10335008	1	

The data above are subject to change without notice.

(8) Model:GWHD(36)NK3AO(CN860W0011)

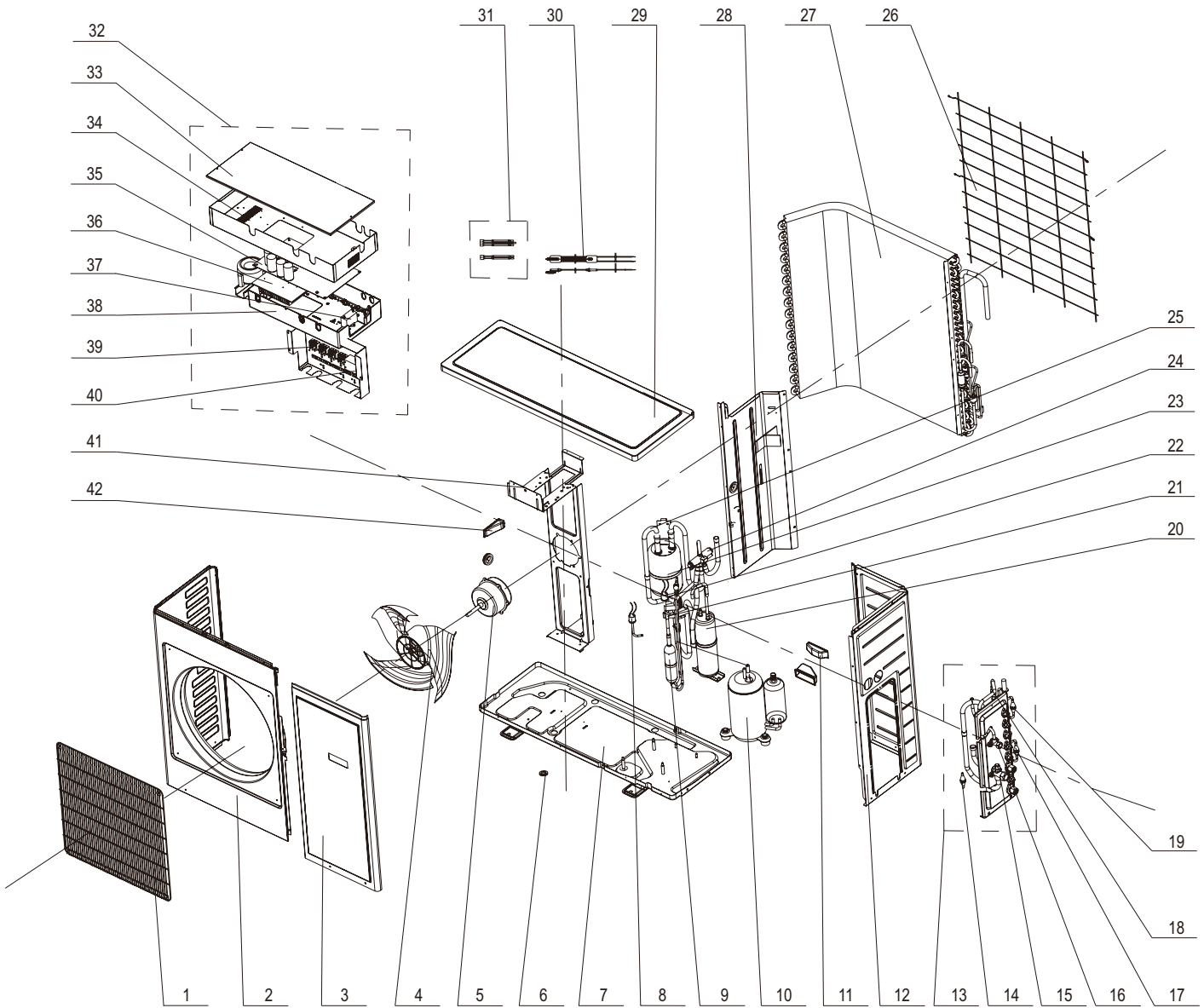

NO.	Description	Part Code		Qty
		GWHD(36)NK3AO		
		CN860W0011		
1	Front Grill	01473001	1	
2	Cabinet	01433011	1	
3	Front Side Plate	01305247	1	
4	Axial Flow Fan	10335253	1	
5	Fan Motor	1501350202	1	
6	Drainage Plug	06813401	2	
7	Chassis Sub-assy	01194310P	1	
8	Pressure Protect Switch	4602001555	1	
9	Oil Separator	07424118	1	
10	Compressor and fittings	00105036	1	
11	Handle	26235253	2	
12	Right Side Plate	01314320	1	
13	Valve support assy	01804398	1	
14	StrainerA	07210022	1	
15	Cut-off Valve	07334402	1	
16	Cut-off Valve	07334403	1	
17	StrainerA	07210022	1	
18	Strainer	07212121	1	
19	StrainerA	07210022	1	
20	Bidirection Accumulator	07228741	1	
21	4-Way Valve Assy	04144307	1	
22	Pressure Protect Switch	4602000902	1	
23	Gas-liquid Separator	07220030	1	
24	4-way Valve	43000411	1	
25	Inhalation Tube Sub-Assy	04674615	1	
26	Rear Grill	01475252	1	
27	Condenser Assy	01124188	1	
28	Clapboard	0123304301	1	
29	Top Cover	01255013P	1	
30	electrical heater	76518732	1	
31	Sensor Sub-assy	39008072	1	
32	Electric Box Assy	01395143	1	
33	Electric Box Cover	01424271	1	
34	Electric Box Sub-Assy	02404128	1	
35	Main Board	30226252	1	
36	Radiator	49018029	1	
37	Capacitor CBB61	33010027	1	
38	Electric Box	26905211	1	
39	Terminal Board	420111041	4	
40	Terminal Board	42010270	1	
41	Motor Support	01705007	1	
42	left handle	26235401	1	

The data above are subject to change without notice.

(9) Model:GWHD(42)NK3AO(CN860W0020)

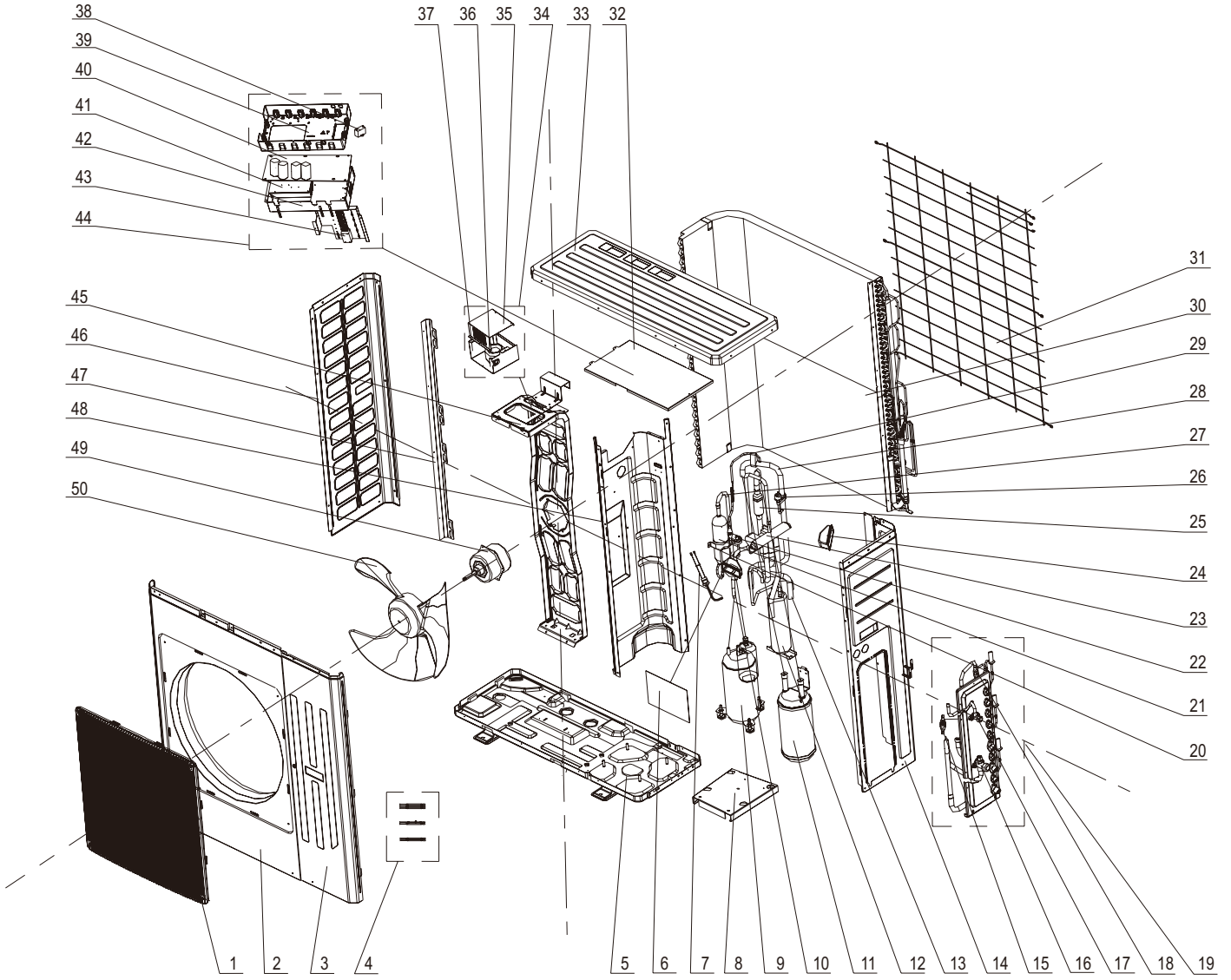

NO.	Description	Part Code		Qty
		GWHD(42)NK3AO		
		CN860W0020		
1	Front Grill	22415005	1	
2	Cabinet	01435007P	1	
3	Front Side Plate Sub-Assy	01305508	1	
4	Sensor sub-assy	39008066	1	
5	Chassis Sub-assy	01194141P	1	
6	Insulated board (cover of electric box)	20113003	1	
7	Pressure Protect Switch	4602000902	1	
8	Compressor Mounting Plate Sub-Assy	01324238	1	
9	Compressor and fittings	00205230	1	
10	Connection Pipe	05034302	1	
11	Gas-liquid Separator Sub-Assy	07225018	1	
12	Bidirection Accumulator	07228741	1	
13	connecting pipe of "U"shape	05034290	1	
14	Right Side Plate Sub-Assy	01314304	1	
15	StrainerA	07210022	1	
16	Cut-off Valve	07334403	1	
17	Cut-off Valve	07334402	1	
18	StrainerA	07210022	1	
19	Valve support assy	01804238	1	
20	Oil Separator	07228302	1	
21	Tube Clip	0214000521	1	
22	StrainerA	07210022	1	
23	4-way Valve	43000338	1	
24	Handle	26235253	2	
25	4-way Valve Assy	04144185	1	
26	Pressure Protect Switch	4602001555	1	
27	Discharge Tube Sub-Assy	04634310	1	
28	Inhalation Tube Sub-Assy	04674230	1	
29	Capillary Sub-Assy(Oil Separator)	04104239	1	
30	Condenser Assy	01124179	1	
31	Rear Grill	01475012	1	
32	Electric Box Cover	01424263	1	
33	Top Cover	01255009	1	
34	Reactor Sub-Assy	02404111	1	
35	Cover of Reactor box	01424260	1	
36	PFC Inductance	43128003	1	
37	Reactor Box	01424258	1	
38	Capacitor	33010009	1	
39	Electric Box	26905211	1	
40	Main Board	30226254	1	
41	Radiator	49018112	1	
42	Electric Box Sub-Assy	02404112	1	

43	Terminal Board	42010270	1
44	Electric Box Assy	02404113	1
45	Motor Support Sub-Assy	01805402	1
46	Left Side Plate	01305064P	1
47	Condenser support plate	01895309	1
48	Clapboard	01244141	1
49	Fan Motor	1570522801	1
50	Axial Flow Fan	10335010	1

The data above are subject to change without notice.

9. Troubleshooting

9.1 Malfunction Indicator

Note: ○: off ●: on ◎: blink

When several malfunctions occur at the same time, they will be displayed in circulation and every malfunction is displayed for 5s.

NO	Malfunction description	LED1	LED2	LED3	LED4
0	Normal stop	○	○	○	○
1	Compressor run	●	○	○	○
2	Compressor overload protection	◎	○	○	○
3	Discharge protection	○	●	○	○
4	Outdoor unit overload protection	●	●	○	○
5	High pressure protection	◎	●	○	○
6	Over current protection	○	◎	○	○
7	IMP protection	●	◎	○	○
8	IMP over heating protection	◎	◎	○	○
9	PFC protection (including PFC overheating protection)	○	○	●	○
10	Phase current protection	●	○	●	○
11	Over voltage protection	◎	○	●	○
12	Insufficient voltage protection	○	●	●	○
13	Start failure	●	●	●	○
14	Compressor desynchronizing	◎	●	●	○
15	Compressor phase-lacking protection	○	◎	●	○
16	Compressor phase current detection malfunction	●	◎	●	○
17	Memory chip mistake	◎	◎	●	○
18	DC power supply circuit-short	○	○	◎	○
19	Defrosting	●	○	◎	○
20	Oil return	◎	○	◎	○
21	Complete unit frequency restriction protection	○	●	◎	○
22	Complete unit frequency dropping protection	●	●	◎	○
23	Unit A frequency restriction or frequency dropping protection	◎	●	◎	○
24	Unit B frequency restriction or frequency dropping protection	○	◎	◎	○
25	Unit C frequency restriction or frequency dropping protection	●	◎	◎	○
26	Unit D frequency restriction or frequency dropping protection	◎	◎	◎	○
27	Outdoor ambient temperature sensor protection	○	○	○	●
28	Outdoor tube temperature sensor protection	●	○	○	●
29	Discharge temperature sensor protection	◎	○	○	●
30	IPM thermal resistance malfunction	○	●	○	●
31	Unit A liquid pipe temperature sensor malfunction	●	●	○	●
32	Unit A gas pipe temperature sensor malfunction	◎	●	○	●
33	Unit B liquid pipe temperature sensor malfunction	○	◎	○	●
34	Unit B gas pipe temperature sensor malfunction	●	◎	○	●
35	Unit C liquid pipe temperature sensor malfunction	◎	◎	○	●
36	Unit C gas pipe temperature sensor malfunction	○	○	●	●
37	Unit D liquid pipe temperature sensor malfunction	●	○	●	●
38	Unit D gas pipe temperature sensor malfunction	◎	○	●	●
39	Unit A mode conflict	○	●	●	●
40	Unit B mode conflict	●	●	●	●
41	Unit C mode conflict	◎	●	●	●
42	Unit D mode conflict	○	◎	●	●

43	Communication failure with Unit A	●	◎	●	●
44	Communication failure with Unit B	◎	◎	●	●
45	Communication failure with Unit C	○	○	◎	●
46	Communication failure with Unit D	●	○	◎	●
47	Unit A freeze protection	◎	○	◎	●
48	Unit B freeze protection	○	●	◎	●
49	Unit C freeze protection	●	●	◎	●
50	Unit D freeze protection	◎	●	◎	●
51	Unit A overheating prevention protection	○	◎	◎	●
52	Unit B overheating prevention protection	●	◎	◎	●
53	Unit C overheating prevention protection	◎	◎	◎	●
54	Unit D overheating prevention protection	○	○	○	◎
55	Unit A communication wire misconnection or expansion valve malfunction	●	○	○	◎
56	Unit B communication wire misconnection or expansion valve malfunction	◎	○	○	◎
57	Unit C communication wire misconnection or expansion valve malfunction	○	●	○	◎
58	Unit D communication wire misconnection or expansion valve malfunction	●	●	○	◎

9.2 Malfunction Checking and Elimination

Note: discharge the position in below pictures with discharge resistance after open the top cover and check if the voltage is below 20V with universal meter, then begin to check.

14/18K:

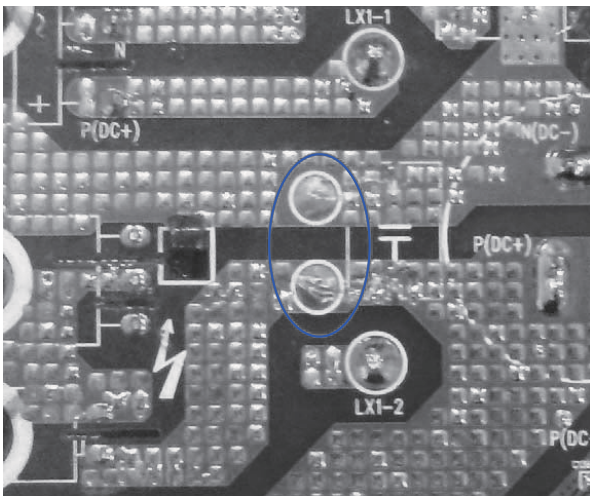

24/28K:

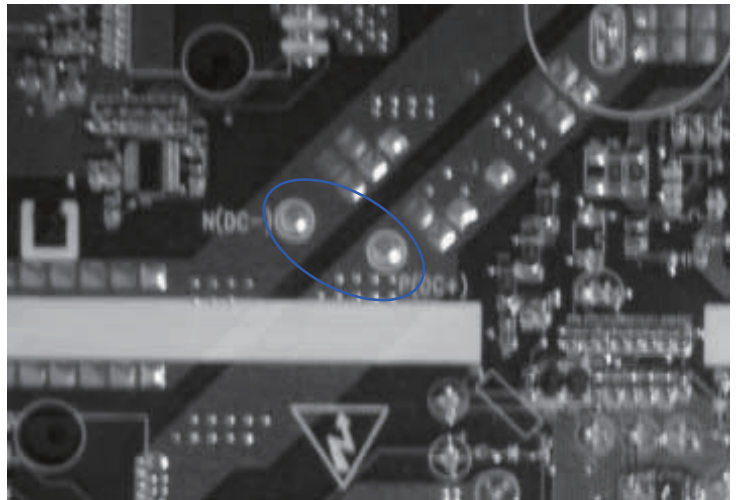

(1) IPM protection malfunction:

Main checking point:

- If the input voltage of the unit is within normal range?
- If the connection wire of compressor is connected well? Is it loose? If the connection sequence is correct?
- If the resistance of compressor coil is normal? If the isolation of compressor coil with copper pipe is good?
- If the unit is overloaded? If the heat radiation of the unit is good?
- If the refrigerant charge is suitable?

Flow chart:

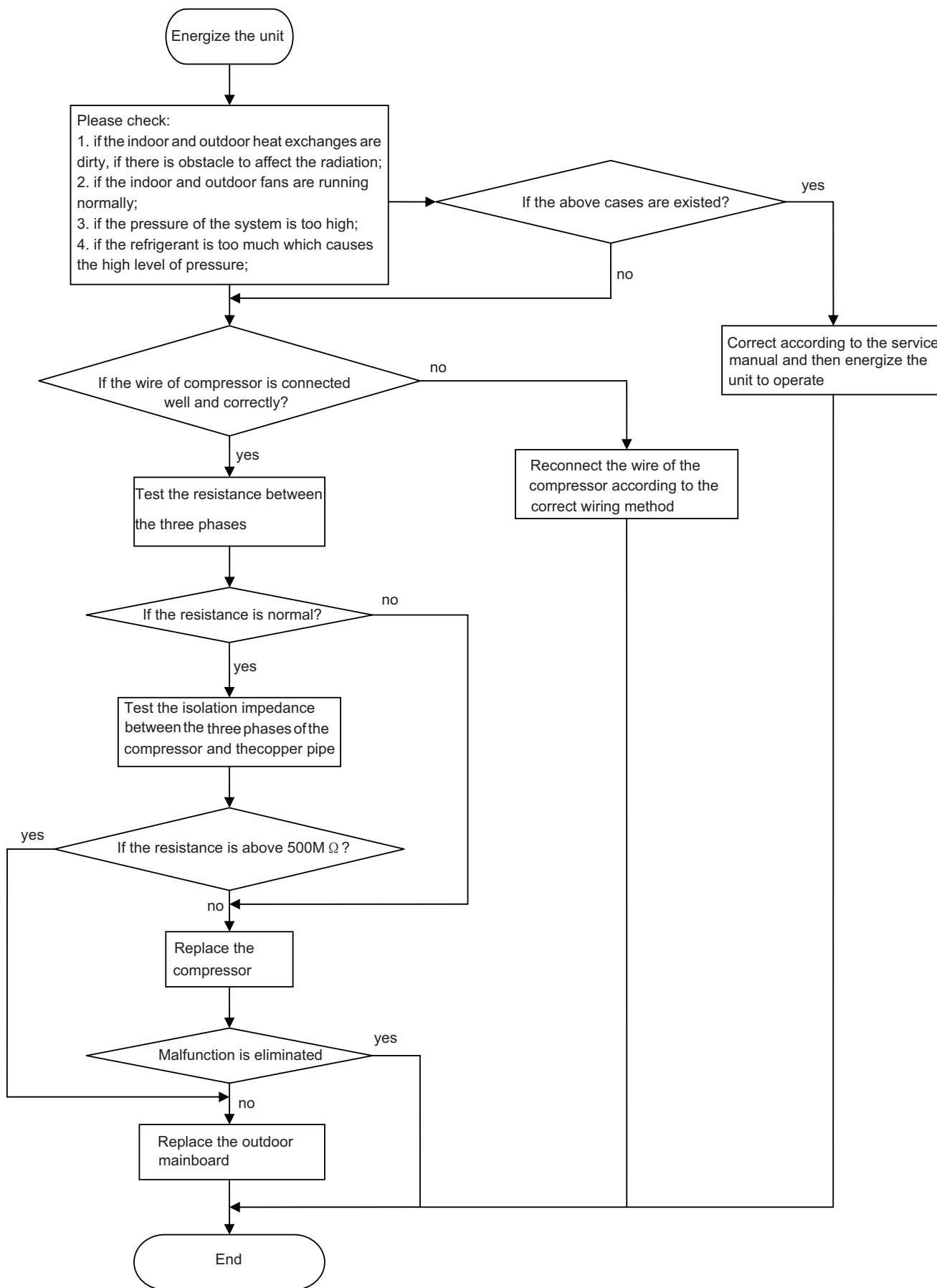

(2) PFC protection malfunction

Main checking points:

- If the power supply is normal;
- Check if the connection wire of induction is connected well and if the induction is broken;

Flow chart:

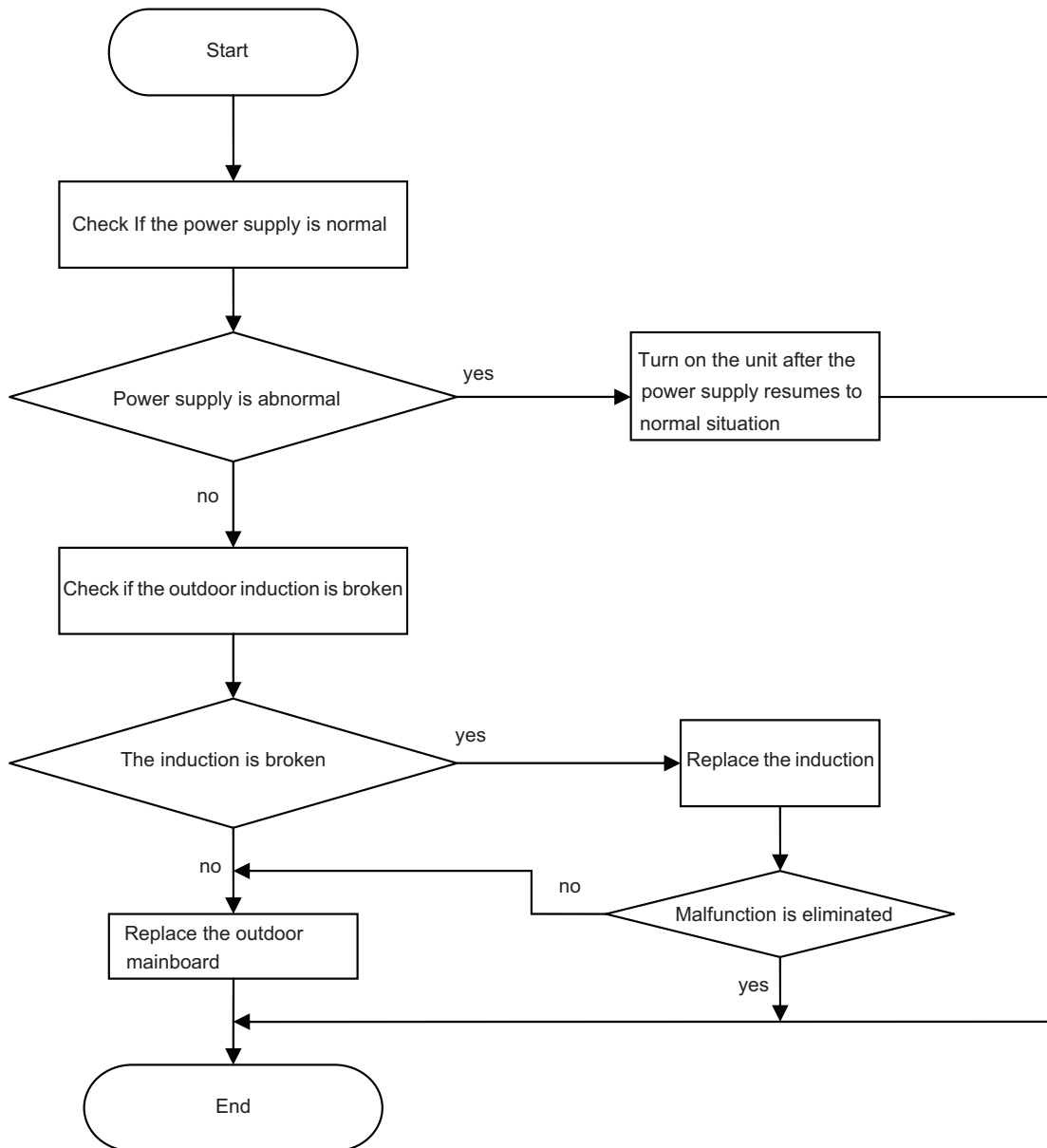

(3) Capacity charging malfunction

Main checking points:

- If the wiring of the induction is connected well and if the induction is broken;
- If the mainboard is broken;

Flow chart:

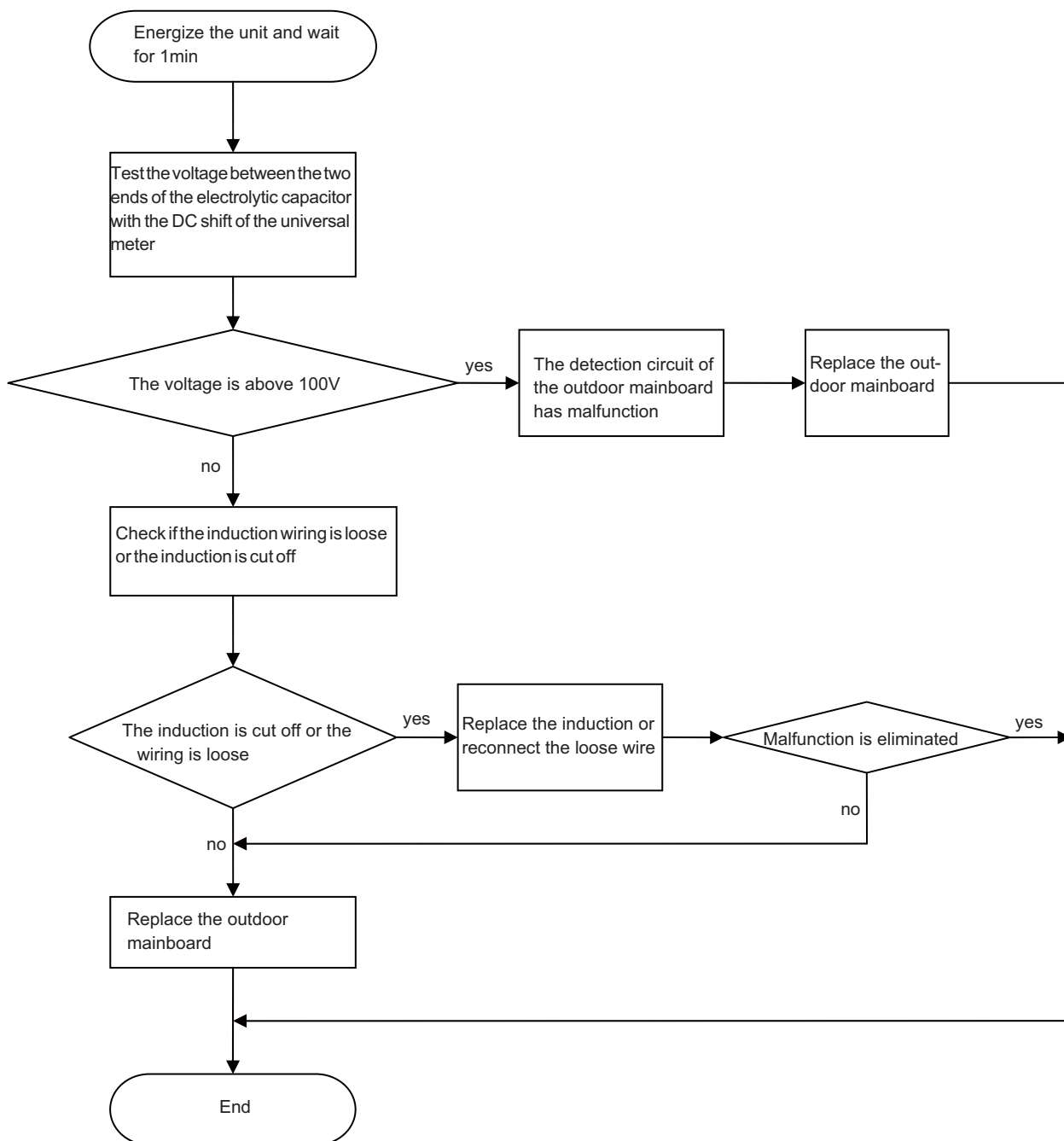

(4) Anti-high temperature and overload malfunction

Main checking points:

- If the outdoor ambient temperature is within the normal range;
- If the outdoor fan is running normally;
- If the indoor and outdoor radiation environment is good;

Flow chart:

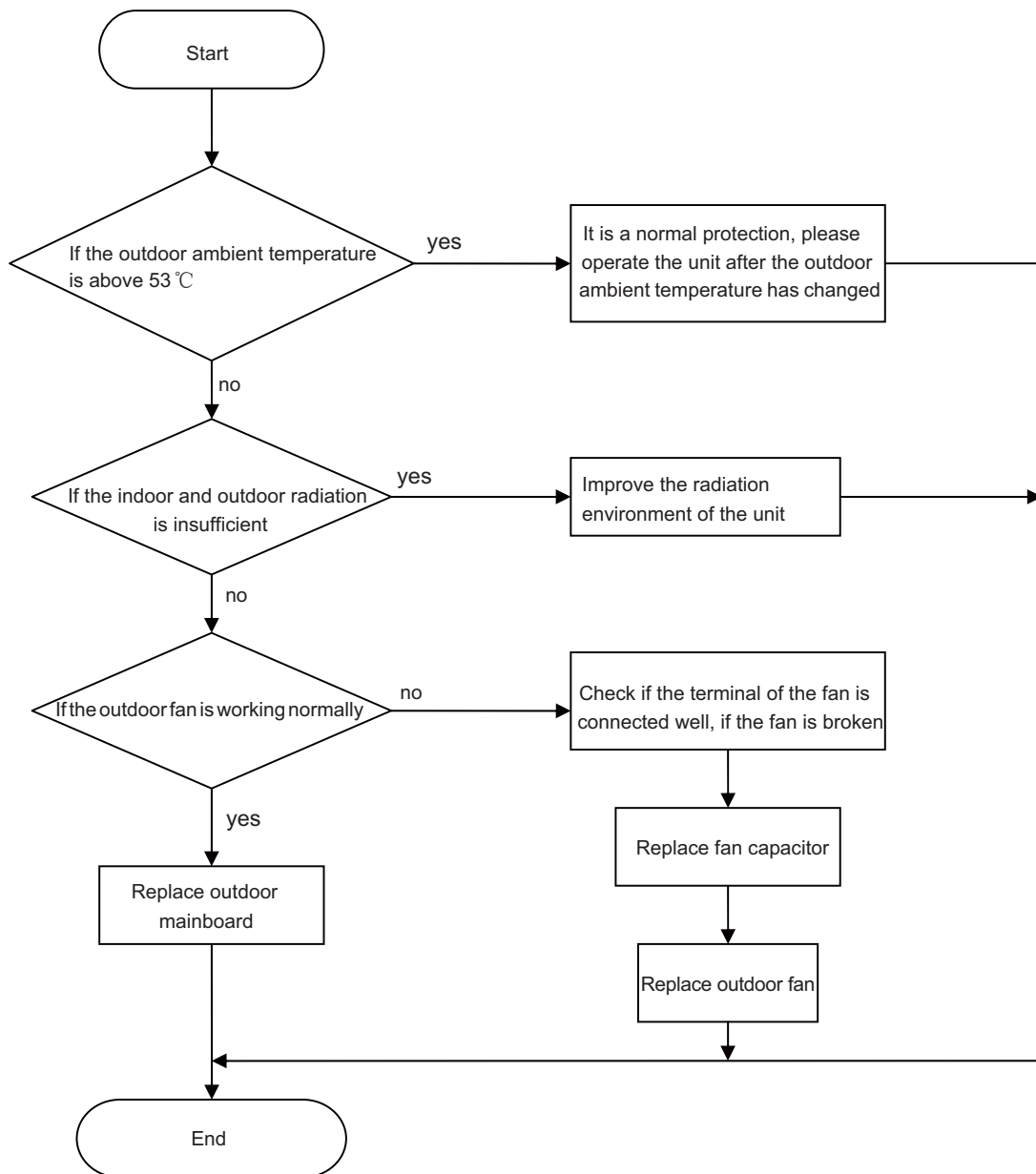

(5) Temperature sensor malfunction

Main checking points:

- If the temperature sensor is damaged or broken
- If the terminal of the temperature sensor is loosened or not connected;
- If the mainboard is broken;

Flow chart:

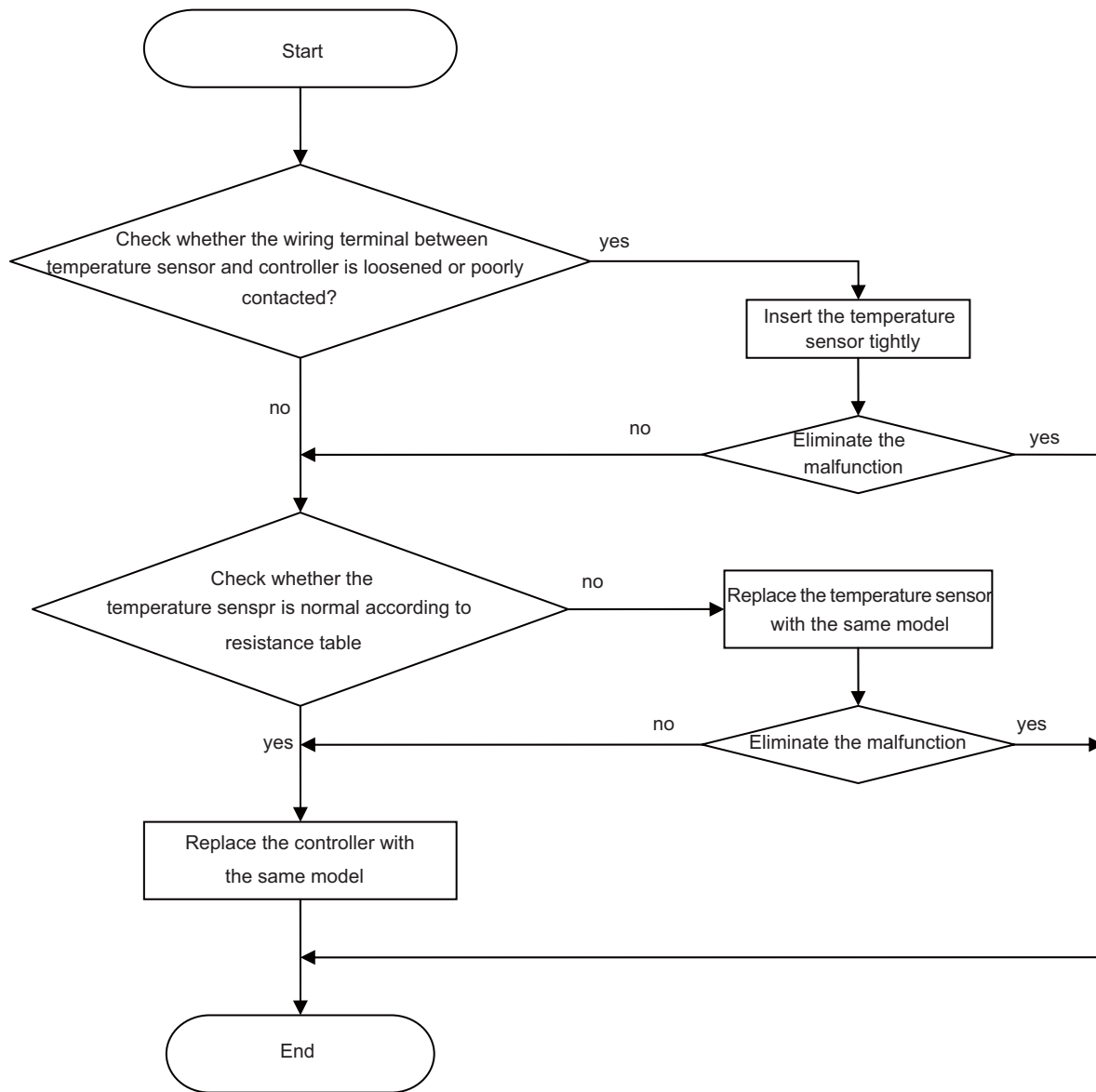

(6) Start failure malfunction

Main checking points:

- If the connection wire of the compressor is connected properly;
- If the stop duration of the compressor is sufficient;
- If the compressor is broken;
- If the refrigerant charging amount is too much;

Flow chart:

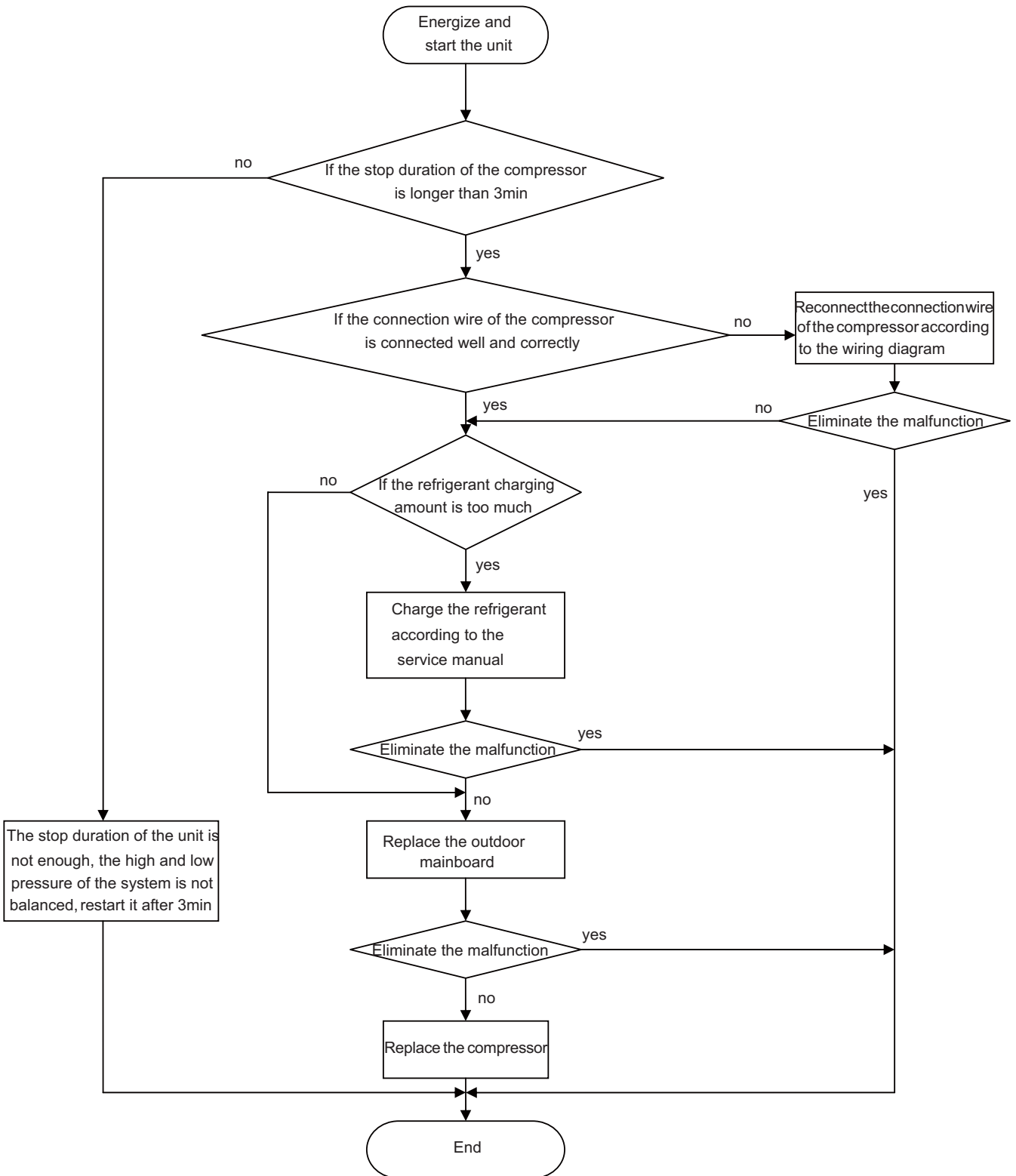

(7) Communication malfunction

Main checking points:

- If the connection wire between the indoor unit and outdoor unit is connected well, if the wires inside the unit is connected well;
- If the indoor mainboard or outdoor main board is broken;

Flow chart:

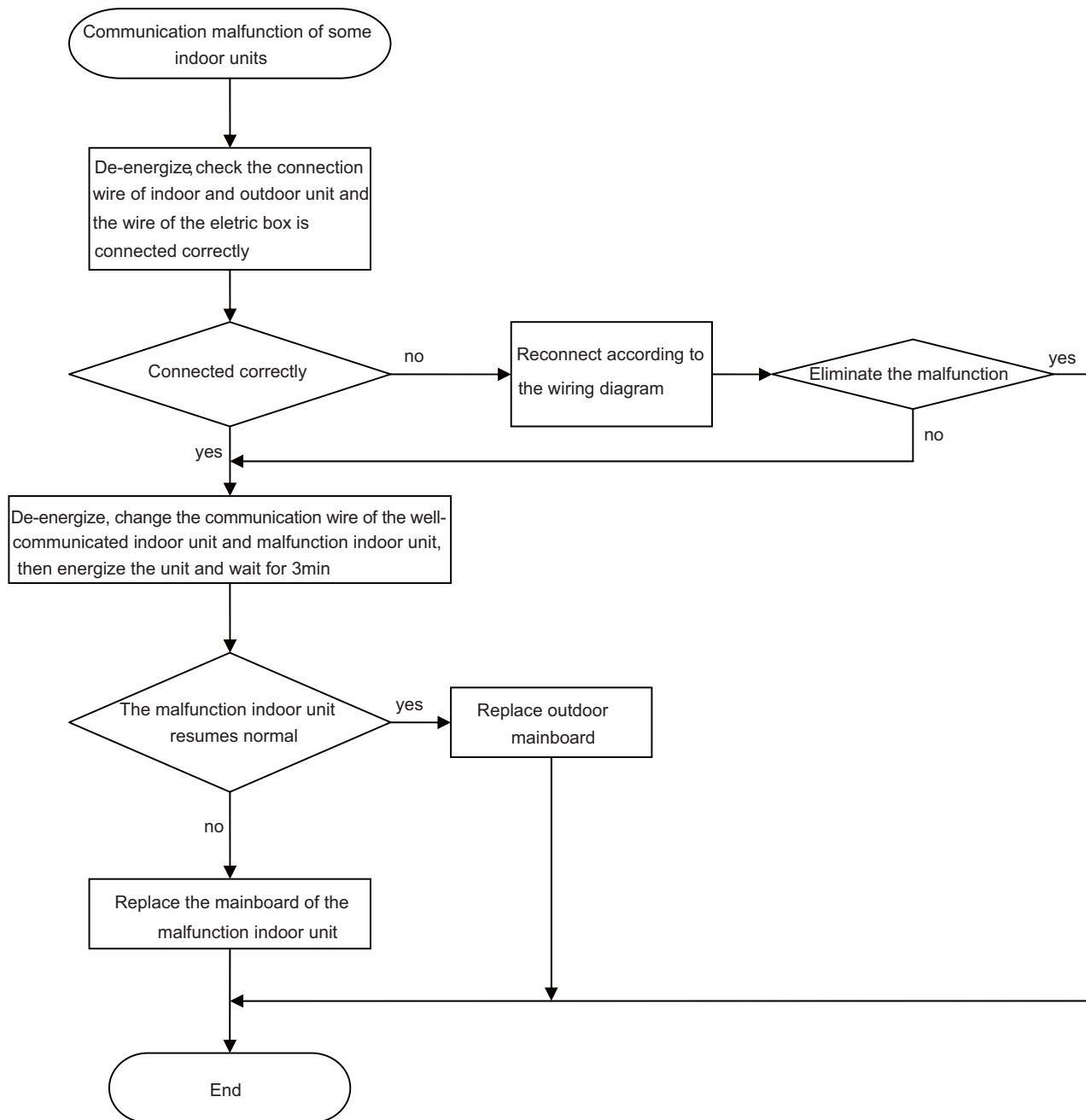

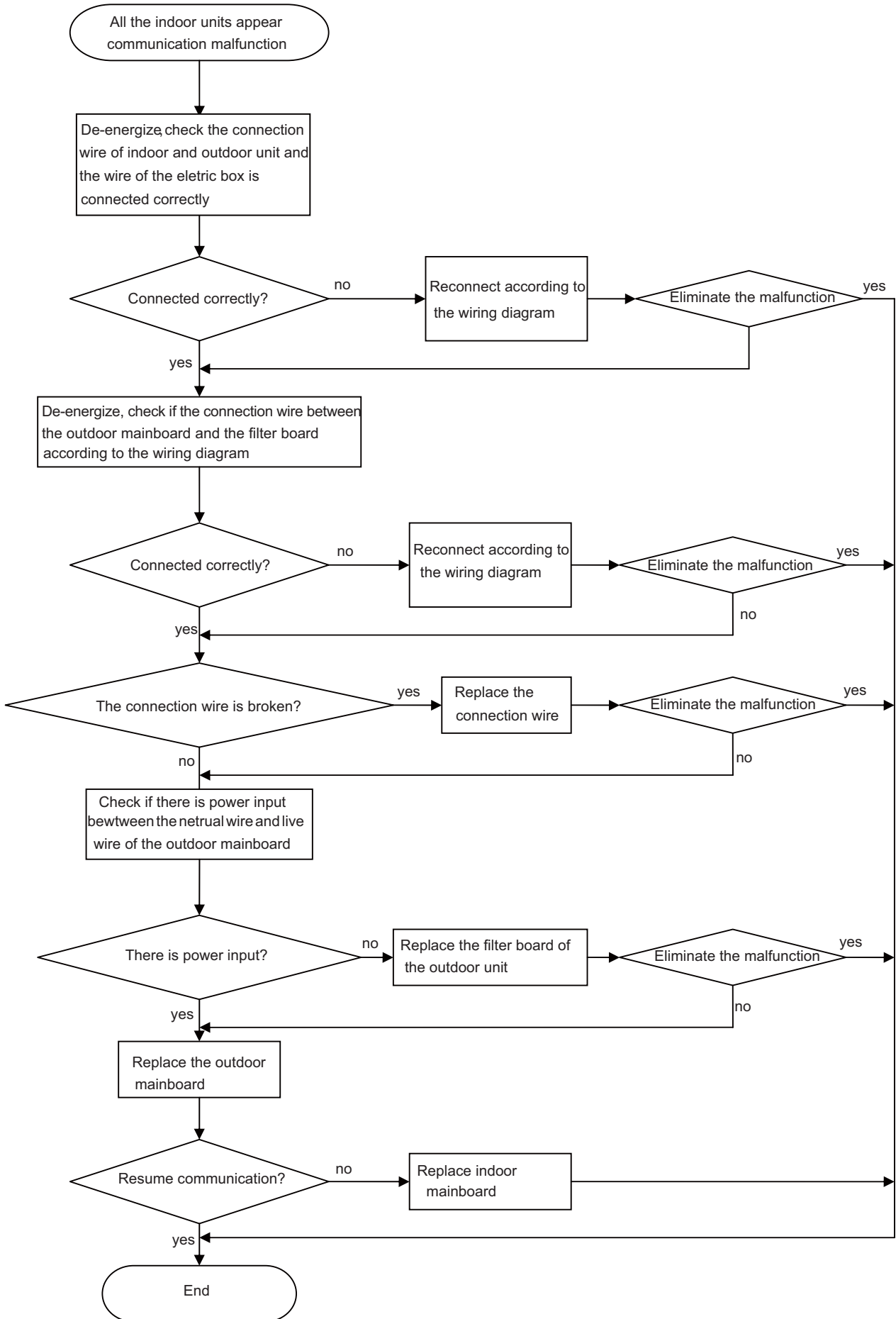

(8) Compressor overload, discharge protection malfunction

Main checking points:

- If the electric expansion valve is connected well or it is broken;
- If there is refrigerant leakage;
- If the overload protector is broken;

Flow chart:

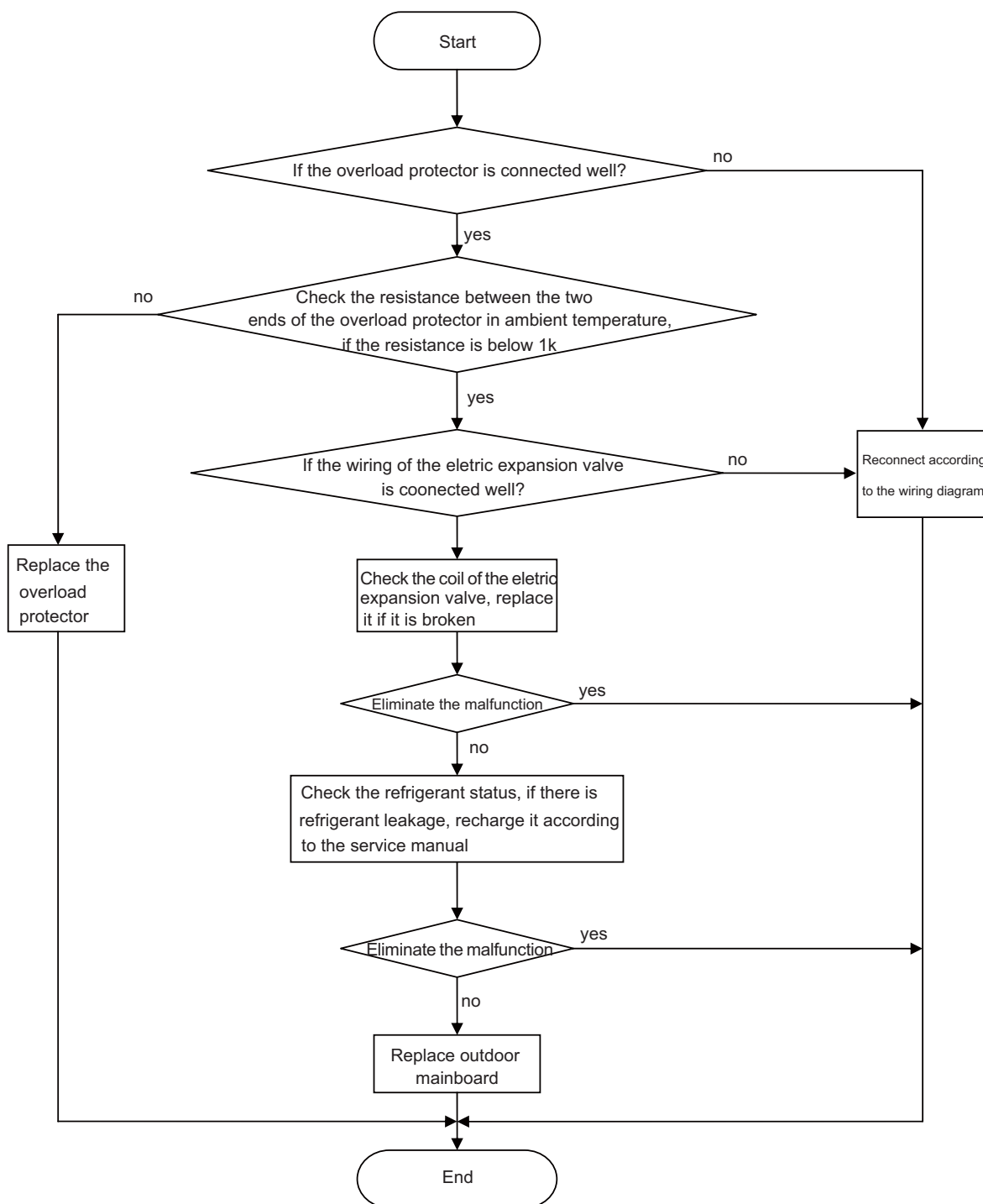

Noted: the detection method of the coil of the electric expansion valve: there is five pieces of the coil of the electric expansion valve, the resistance of one of them (the leftmost or the rightmost one) is almost the same as the resistance of other terminal (within 100 Ω). Judge the condition of the electronic expansion valve through detecting these resistance.

(9) Compressor desynchronizing malfunction

Main checking points:

- If the pressure of the system is too high;
- If the electric expansion valve is working normally or it is broken;
- If the radiation of the unit is good;

Flow chart:

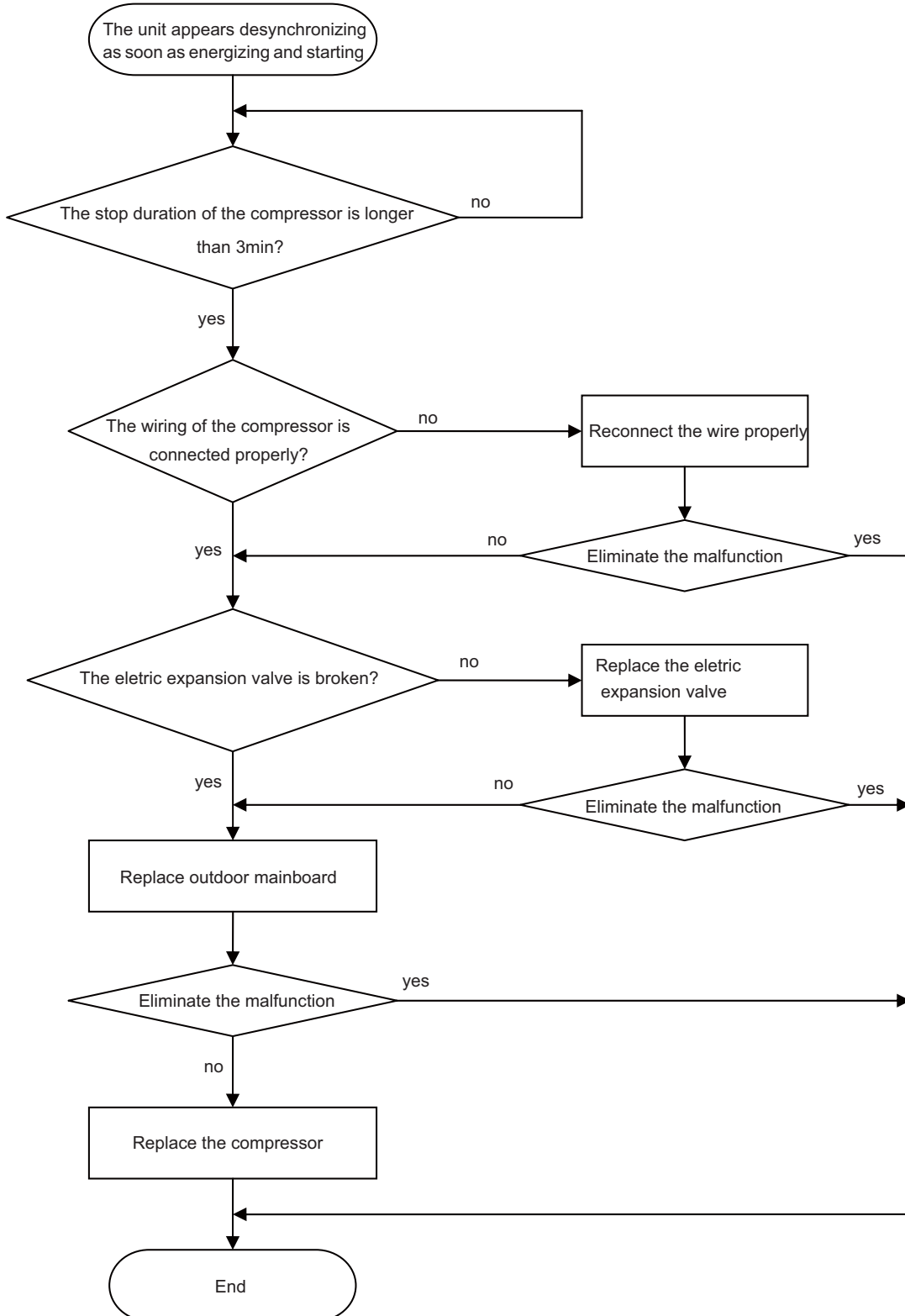

9.3 Models:36K and 42K

1. Trouble Table

WARNING!

a. In the event of abnormal conditions (like, stinky smell), please shut off the main power supply immediately and then contact the GREE appointed service center; otherwise the continuous abnormal running would damage the air conditioning unit and also would cause electric shock or fire hazard etc.

b. Do not repair the air conditioning personally but instead contact the professionally skilled personnel at the GREE appointed service center, as the incorrect repair would cause electric shock or fire hazard etc.

1.1 Check before Contacting Service Center

Please check the following items before contacting the maintenance serviceman.

Conditions	Causes	Corrective Actions
The unit does not run	Broken fuse or opened breaker	Change the fuse or close the breaker
	Power off	Restart the unit when power on
	Loosened power supply plug.	Plug the power supply properly.
	Insufficient batteries voltage of the remote controller	Change new batteries
	Remoter controller out of the control scope	Keep the control distance within 8 meters.
The unit stops soon after it starts	Clogged inlet/outlet of the indoor/outdoor unit	Clear the obstacle
Cooling/Heating is abnormal	Clogged inlet/outlet of the indoor/outdoor unit	Clear the obstacle
	Improperly set temperature	Adjust the setting of the remote or wired controller.
	Too low set fan speed	Adjust the setting of the remote or wired controller.
	Improper airflow direction	Adjust the setting of the remote or wired controller.
	Opened door and window	Close the door and window
	Direct sunlight	Hang a curtain or blinds over the window.
	Too much people in the room	
	Too much heat sources in the room	Reduce the heat sources
	Dirty filter screen	Clean the filter screen

Note: If the air conditioner still runs abnormally after the above check and handling, please contact the maintenance serviceman at the local appointed service center and also give a description of the error occurred as well as the model of the unit

1.2 Problem Handling

The conditions listed below are not classified into errors.

Conditions	Causes	
The unit does not run	When restart the unit soon after it is stopped.	The overload protection switch of the unit let the startup delayed for three minutes.
	As soon as power is on.	The unit will stand by for approximate one minute.
The unit blows out mist	When the cooling operation starts.	The hi-humidity air indoor is cooled quickly.
The unit generates noise	The unit "clatters" as soon as it starts running.	It is the sound generated during the initialization of the electronic expansion valve.
	The unit "swishes" during the cooling operation.	It is the sound when the refrigerant gas runs inside the unit.
	The unit "swishes" when it is started or stopped.	It is the sound when the refrigerant gas stops running.
	The unit "swishes" when it is in and after the running.	It is the sound when the draining system is operating.
	The unit "squeaks" when it is in and after the running.	It is the sound of friction generated by the skin plate etc which swells due to the temperature change.
The unit blows out dust.	When the unit restarts after it is not used for a long time.	The dust inside the unit is blown out again.
The unit emits odors.	When the unit is running.	The odors absorbed in are blown out again.

1.3 Error Description

If some error occurs when the unit is running, the error code will be displayed on the wired controller and the main board  of the outdoor unit. See the table below for more details about the meaning of each error.

Error & Status Display List					Indoor Unit (Floor/ Ceiling) 88 Display	Wired Controller Display	Indoor and/or Outdoor Unit Error
Errors of Commercial Air Conditioners	Outdoor Unit 88 Display	Indicating LED Flashing Times					
		Running LED	Cooling LED	Heating LED			
Defrosting Mode 1	08	/	/	/	/	/	Outdoor
Defrosting Mode 2	0A	/	/	/	/	/	Outdoor
Whole Unit Running Normally	ON	/	/	/	/	/	Outdoor
(Liquid Valve) Inlet Tube Temp Sensor Error	See Table 2	/	Flash 19 times	/	b5	B5	Outdoor
(Air Valve) Outlet Tube Temp Sensor Error	See Table 2	/	Flash 22 times	/	b7	B7	Outdoor
/	F0	/	Flash 10 times	/	F0	F0	Outdoor
Indoor Ambient Temp. Sensor Short/Open-Circuit	See Table 2	/	Flash once	/	F1	F1	Indoor
Indoor Evaporator Temp Sensor Short/Open-Circuit	See Table 2	/	Flash twice	/	F2	F2	Indoor
Outdoor Ambient Temp Sensor Error	F3	/	Flash 3 times	/	F3	F3	Outdoor
Outdoor Mid-Coil Temp Sensor Error	F4	/	Flash 4 times	/	F4	F4	Outdoor
Outdoor Discharge Air Temp Sensor Error	F5	/	Flash 5 times	/	F5	F5	Outdoor
Oil Return for Cooling	F7	/	/	/	/	/	Outdoor
High Pressure Protection	E1	Flash once	/	/	E1	E1	Outdoor
Shutdown for Whole Unit Anti-Freeze Protection	E2	Flash twice	/	/	E2	E2	Indoor
Low Pressure Protection	E3	Flash 3 times	/	/	E3	E3	Outdoor
High Discharge Temp Protection	E4	Flash 4 times	/	/	E4	E4	Outdoor
Communication Error	See Table 2	Flash 6 times	/	/	E6	E6	Outdoor & Indoor
Mode Conflict	See Table 2	Flash 7 times	/	/	E7	E7	Indoor
Overload Protection	E8	Flash 8 times	/	/	E8	E8	Outdoor
/	E9	/	/	/	/	/	Indoor
Indoor Unit Water Full Error		/	Flashing	Flashing	E9	E9	Indoor
Trial Run	dd	Quick Flashing	Quick Flashing	Quick Flashing	dd	dd	Outdoor
Refrigerant Recovery Mode	Fo	Quick Flashing	Quick Flashing	/	Fo	Fo	Outdoor
IPM Reset	P0	Flash 3 times	Flash 3 times	Flash 3 times	P0	P0	Outdoor
Compressor Current Protection	P5	/	/	Flash 15 times	P5	P5	Outdoor
Communication Error between the Inverter Drive and the Main Controller	P6	Flash 16 times	/	/	P6	P6	Outdoor
Radiator Temp Sensor Error	P7	/	/	Flash 18 times	P7	P7	Outdoor
Radiator Overheat Protection	P8	/	/	Flash 19 times	P8	P8	Outdoor
AC Contactor Protection	P9	Flash 3 times	Flash 3 times	Flash 3 times	P9	P9	Outdoor
Current Sensor Error	Pc	Flash 3 times	Flash 3 times	Flash 3 times	Pc	Pc	Outdoor
Sensor Connection Protection	Pd	Flash 3 times	Flash 3 times	Flash 3 times	Pd	Pd	Outdoor

AC Current Protection (Input Side)	PA	Flash 3 times	Flash 3 times	Flash 3 times	PA	PA	Outdoor
Temp Drift Protection	PE	Flash 3 times	Flash 3 times	Flash 3 times	PE	PE	Outdoor
Drive Board Ambient Temp Sensor Error	PF	Flash 3 times	Flash 3 times	Flash 3 times	PF	PF	Outdoor
Low Voltage Protection	PL	Flash 3 times	Flash 3 times	Flash 3 times	PL	PL	Outdoor
Over Voltage Protection	PH	Flash 3 times	Flash 3 times	Flash 3 times	PH	PH	Outdoor
AC Input Voltage Anomaly	PP	Flash 3 times	Flash 3 times	Flash 3 times	PP	PP	Outdoor
Charging Circuit Error	PU	/	/	Flash 17 times	PU	PU	Outdoor
Oil Return for Heating or Defrosting	H1	/	/	Flash once	H1		Outdoor
Forced Defrosting	H1	Quick Flashing	/	/	H1	H1	Outdoor
Compressor Overheat Protection	H3	/	/	Flash 3 times	H3	H3	Outdoor
IPM Protection	H5	/	/	Flash 5 times	H5	H5	Outdoor
Motor Desynchronizing	H7	/	/	Flash 7 times	H7	H7	Outdoor
PFC Error	Hc	/	/	Flash 6 times	Hc	Hc	Outdoor
/	L9	Flash 20 times	/	/	L9	L9	Outdoor
Startup Failure	Lc	/	/	Flash 11 times	Lc	Lc	Outdoor
Phase Loss	Ld	Flash 3 times	Flash 3 times	Flash 3 times	Ld	Ld	Outdoor
Compressor Stalling	LE	Flash 3 times	Flash 3 times	Flash 3 times	LE	LE	Outdoor
Over-Speed	LF	Flash 3 times	Flash 3 times	Flash 3 times	LF	LF	Outdoor
/	A5	Flash 3 times	Flash 3 times	Flash 3 times	oE	A5	Outdoor
/	A7	Flash 3 times	Flash 3 times	Flash 3 times	oE	A7	Outdoor
/	EE	/	/	/	/	/	Outdoor
/	En	Flash 3 times	Flash 3 times	Flash 3 times	En	En	Outdoor
/	EU	/	Flash 6 times	Flash 6 times	EU	EU	Outdoor
/	F6	/	Flash 6 times	/	F6	F6	Outdoor
/	F8	/	Flash 8 times	/	F8	F8	Outdoor
/	F9	/	Flash 9 times	/	F9	F9	Outdoor
/	FH	/	Flash twice	Flash twice	FH	FH	Outdoor
/	HE	/	/	Flash 14 times	HE	HE	Outdoor
/	LP	Flash 19 times	/	/	LP	LP	Outdoor & Indoor
/	U1	/	/	Flash 12 times	U1	U1	Outdoor
/	U3	/	/	Flash 20 times	/	/	Outdoor
Communication Line Misconnected or Expansion Valve Error	dn	Flash 3 times	Flash 3 times	Flash 3 times	dn	dn	Outdoor

The words in gray means the corresponding function is unavailable.

Table 2

Error Code	Error Description	Error Code	Error Description	Error Code	Error Description
13	Unit A indoor unit pipe outlet temperature sensor error	23	Unit B indoor unit pipe outlet temperature sensor error	33	Unit C indoor unit pipe outlet temperature sensor error
14	Unit A indoor pipe inlet temperature sensor error	24	Unit B indoor pipe inlet temperature sensor error	34	Unit C indoor pipe inlet temperature sensor error
15	Unit A indoor ambient temperature sensor error	25	Unit B indoor ambient temperature sensor error	35	Unit C indoor ambient temperature sensor error
16	Unit A mode conflict	26	Unit B mode conflict	36	Unit C mode conflict
17	Unit A anti-freezing protection	27	Unit B anti-freezing protection	37	Unit C anti-freezing protection
41	Unit D communication error	46	Unit D mode conflict	54	Unit E indoor pipe inlet temperature sensor error
42	Unit D indoor pipe midway temperature sensor error	47	Unit D anti-freezing protection	55	Unit E indoor ambient temperature sensor error
43	Unit D indoor unit pipe outlet temperature sensor error	51	Unit E communication error	56	Unit E mode conflict
44	Unit D indoor pipe inlet temperature sensor error	52	Unit E indoor pipe midway temperature sensor error	57	Unit E anti-freezing protection
45	Unit D indoor ambient temperature sensor error	53	Unit E indoor unit pipe outlet temperature sensor error	C5	Jumper terminal error

Error description of outdoor refrigerant pipe detection function

Wiring error or component error	Unit which is detecting	Unit which isn't detecting
5E	01	**
5E	02	**
5E	03	**
5E	04	**
5E	05	**
Indoor unit gas pipe connection error or component error	Unit which is detecting	--
5P	01	--
5P	02	--
5P	03	--
5P	04	--
5P	05	--

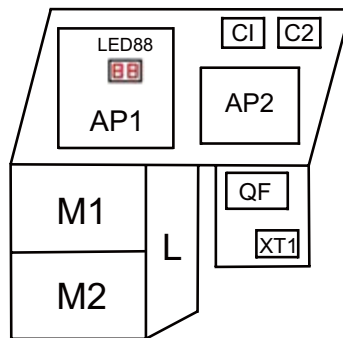

(Note: Refer to the real products for the exact position of each component.)

Once errors are displayed on the controller, please shut off the air conditioning unit and contact the professionally skilled personnel for troubleshooting.

2. Flow Chart of Troubleshooting

Service personnel shall collect the malfunction information as much as possible and research them thoroughly, list these electrical parts which may cause malfunction, service personnel shall be able to determine the specific reason and solve the faulted parts.

Observe the status of the complete device and do not observe the partial

It is advised to start from the simple operation during analyzing ,judging and confirming malfunction reason, then conduct the complicated operations such removal of device, part replacement and refrigerant filling.

Find the malfunction reason carefully as unit may occur several malfunction at the same time and one malfunction may develop into several malfunction, so entire system analysis shall be established to make the judged result exact and credible.

◆ Malfunction display: E1 Compressor High Pressure Protection

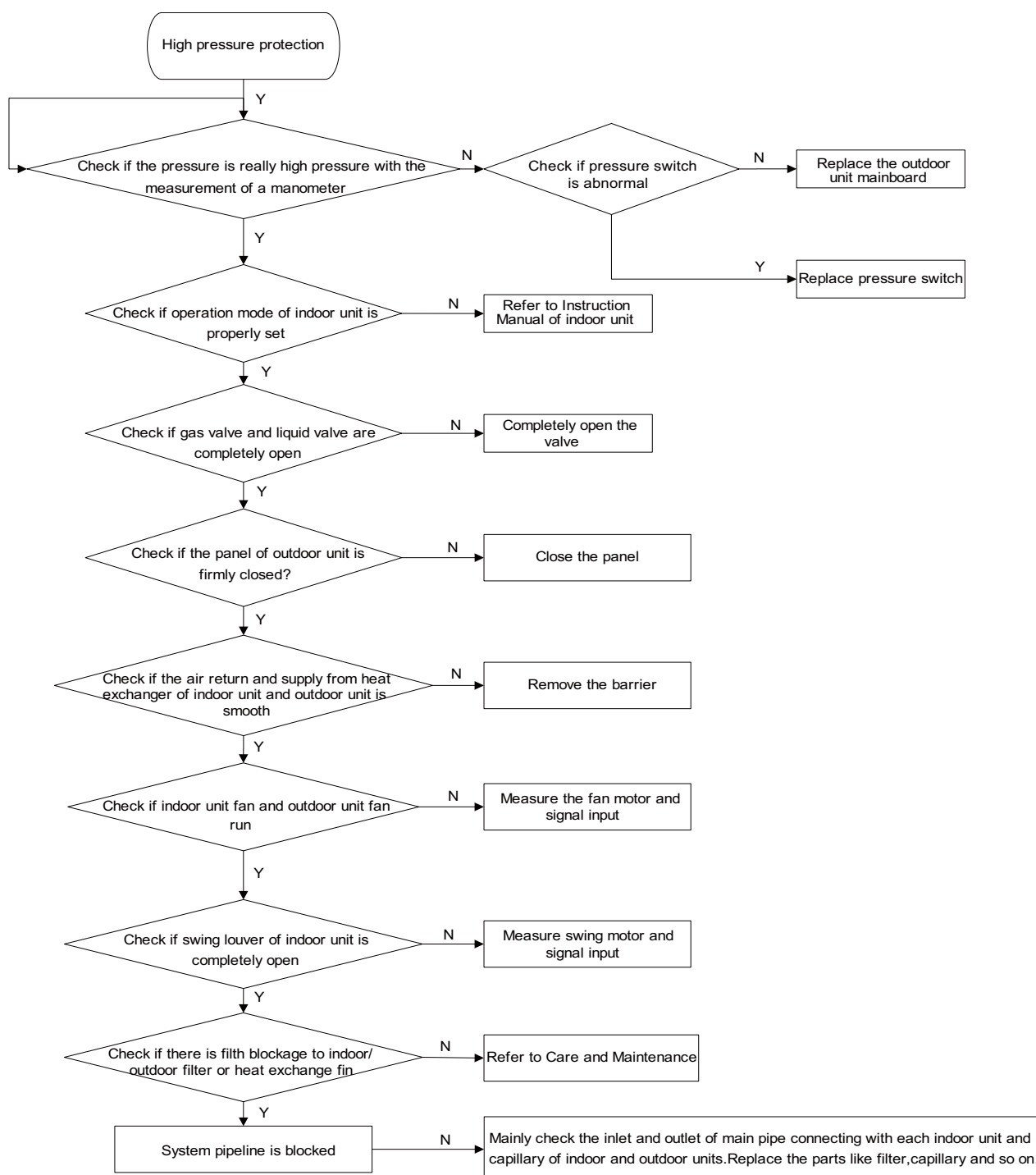

◆ Malfunction display: E3 Compressor Low Pressure Protection

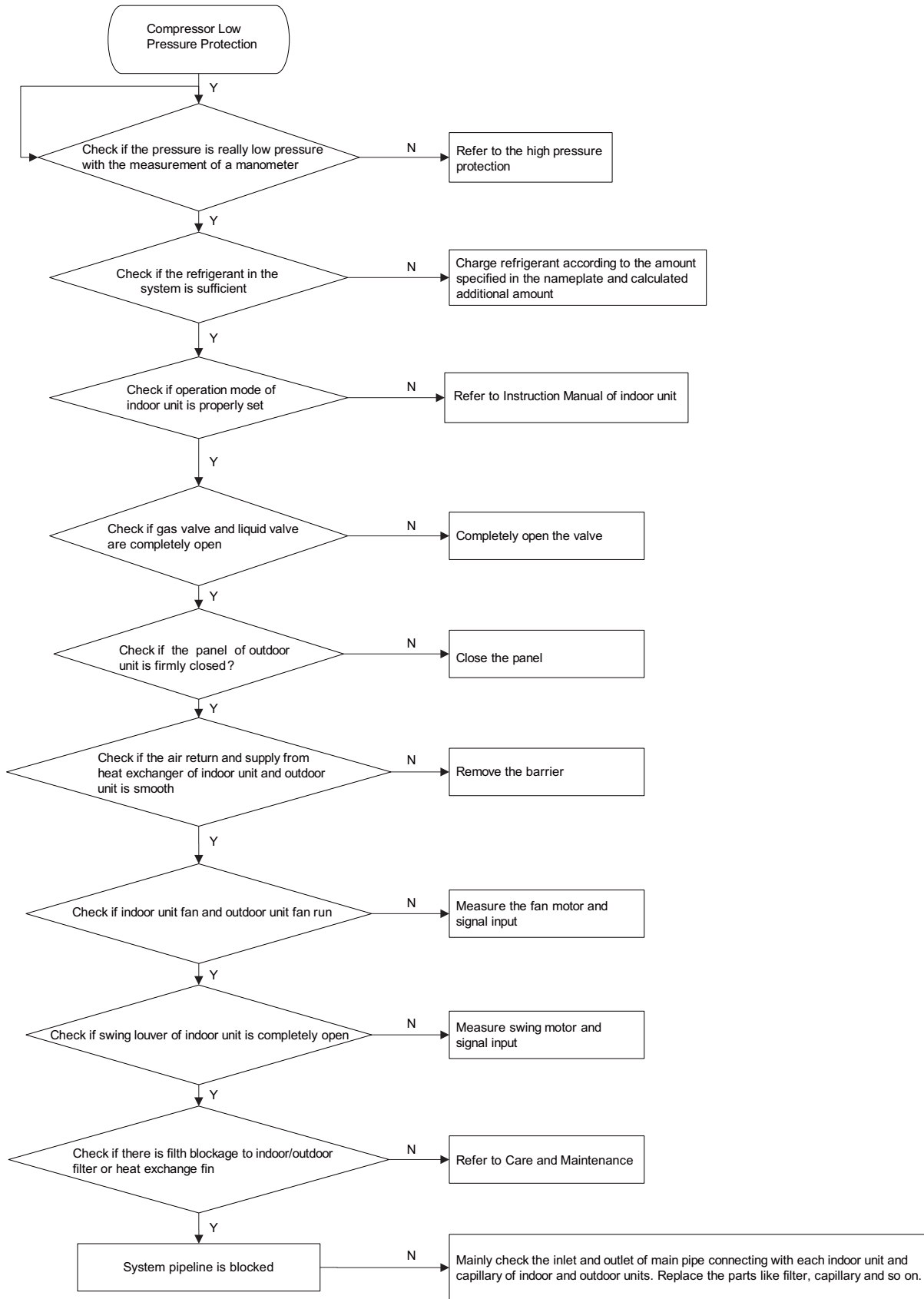

◆ Malfunction display: E4 Compressor Exhaust High Temperature Protection

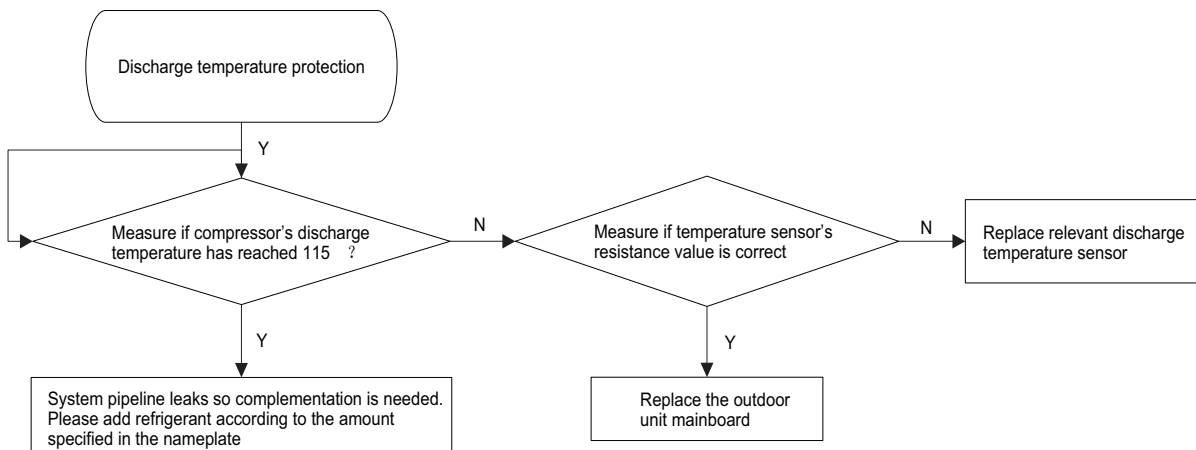

◆ Malfunction display: E5 Compressor Overheat

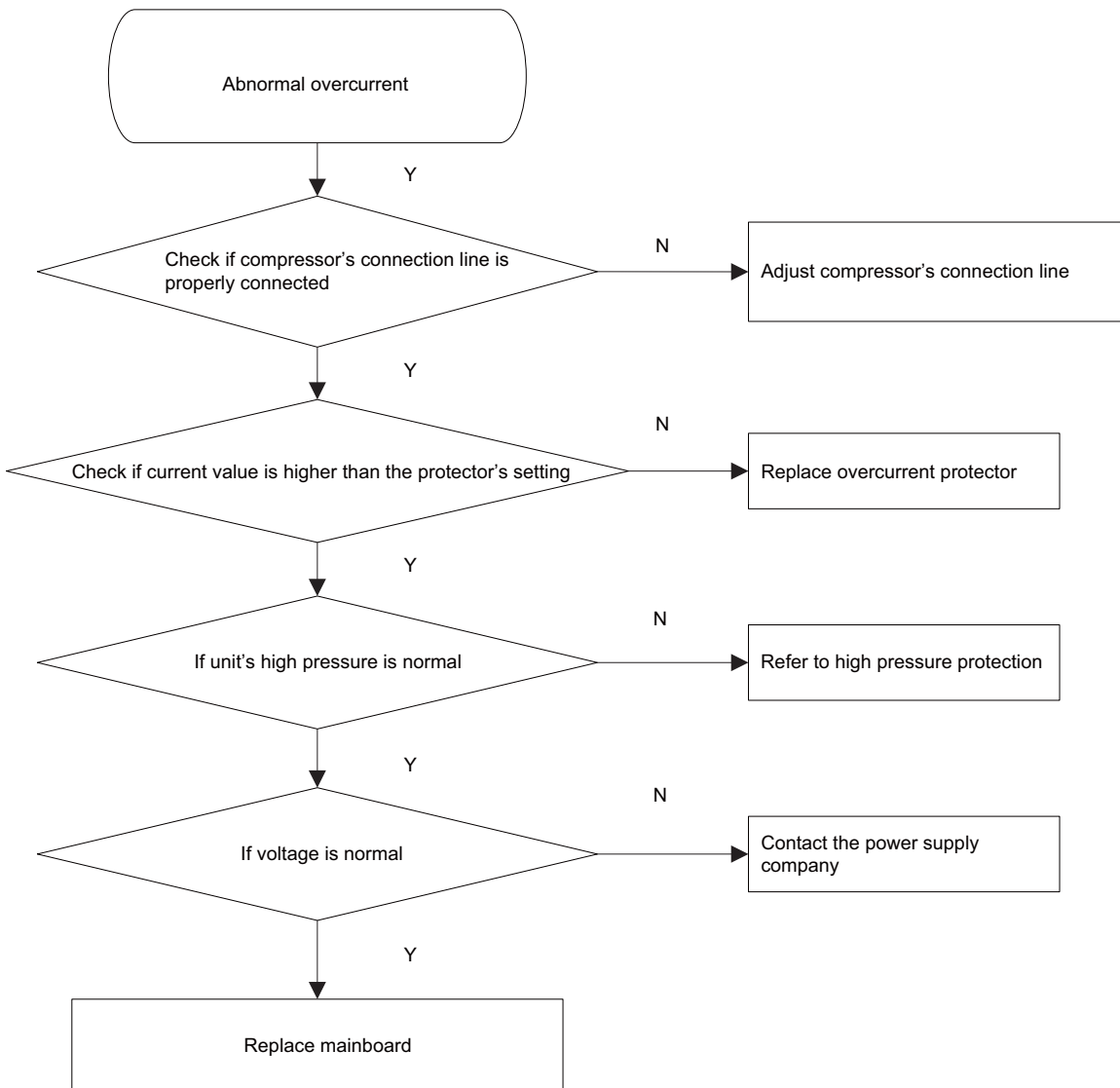

◆ Malfunction display: E9 Full Water Protection

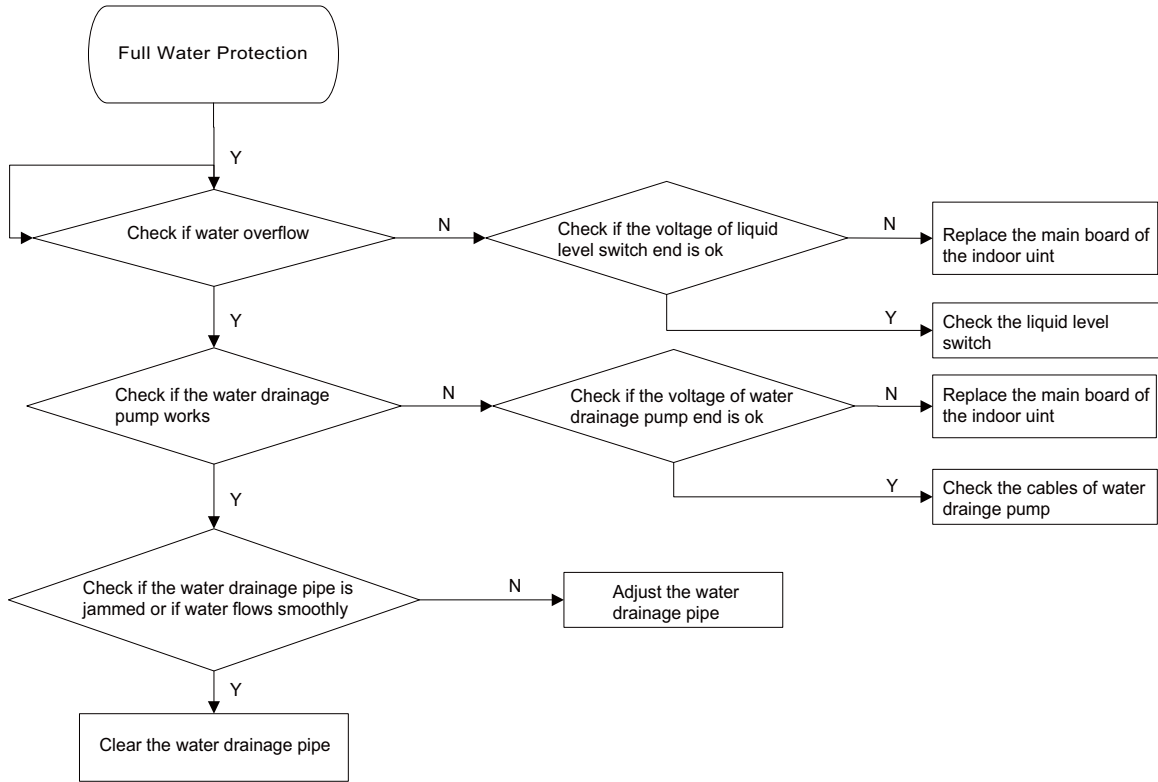

◆ Malfunction display: F2 Failure of Evaporator Temp. Sensor

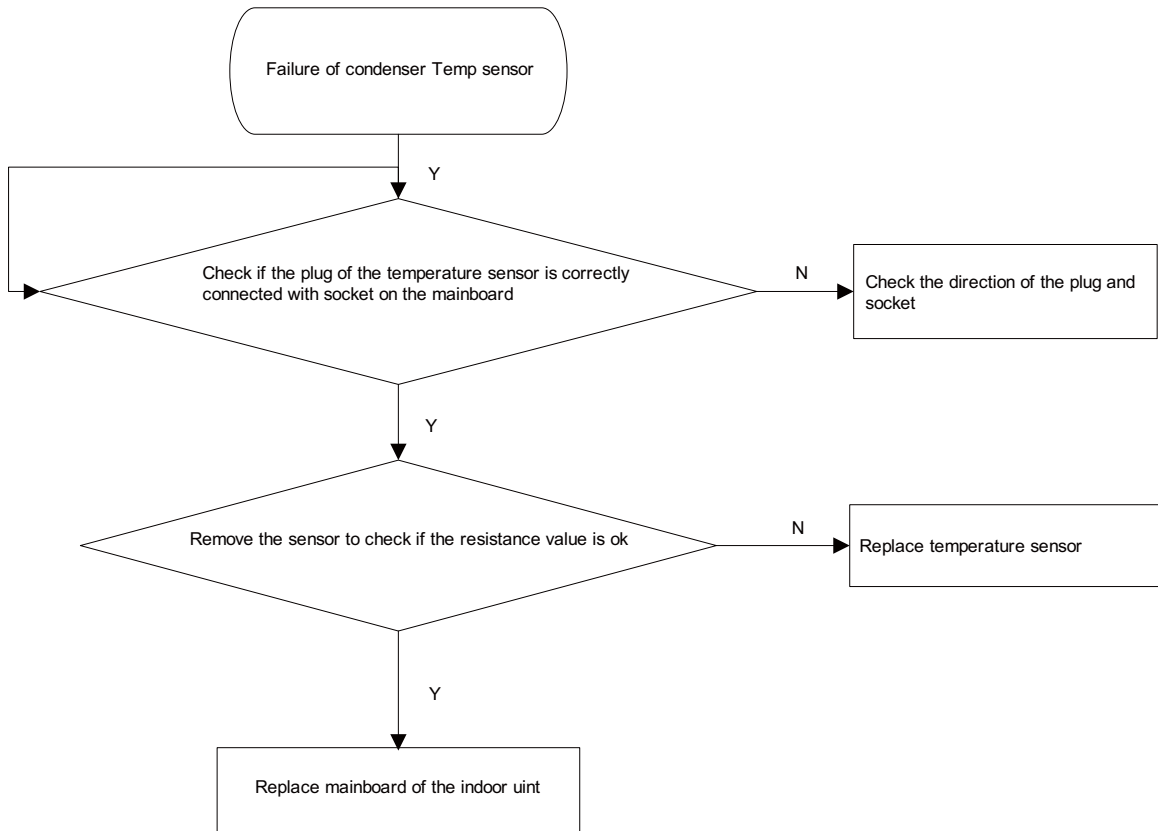

◆ Malfunction display: F3 Failure of Outdoor Ambient Sensor

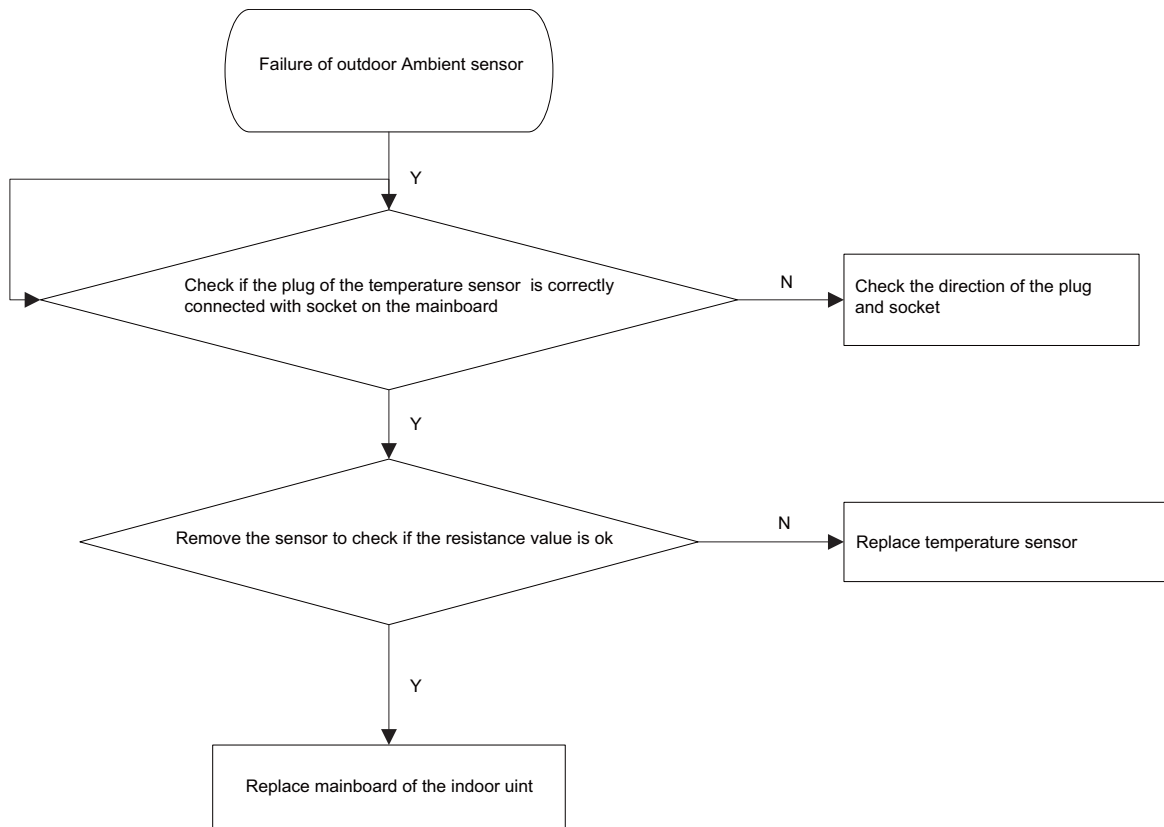

◆ Malfunction display: F5 Failure of Exhaust Temp. Sensor

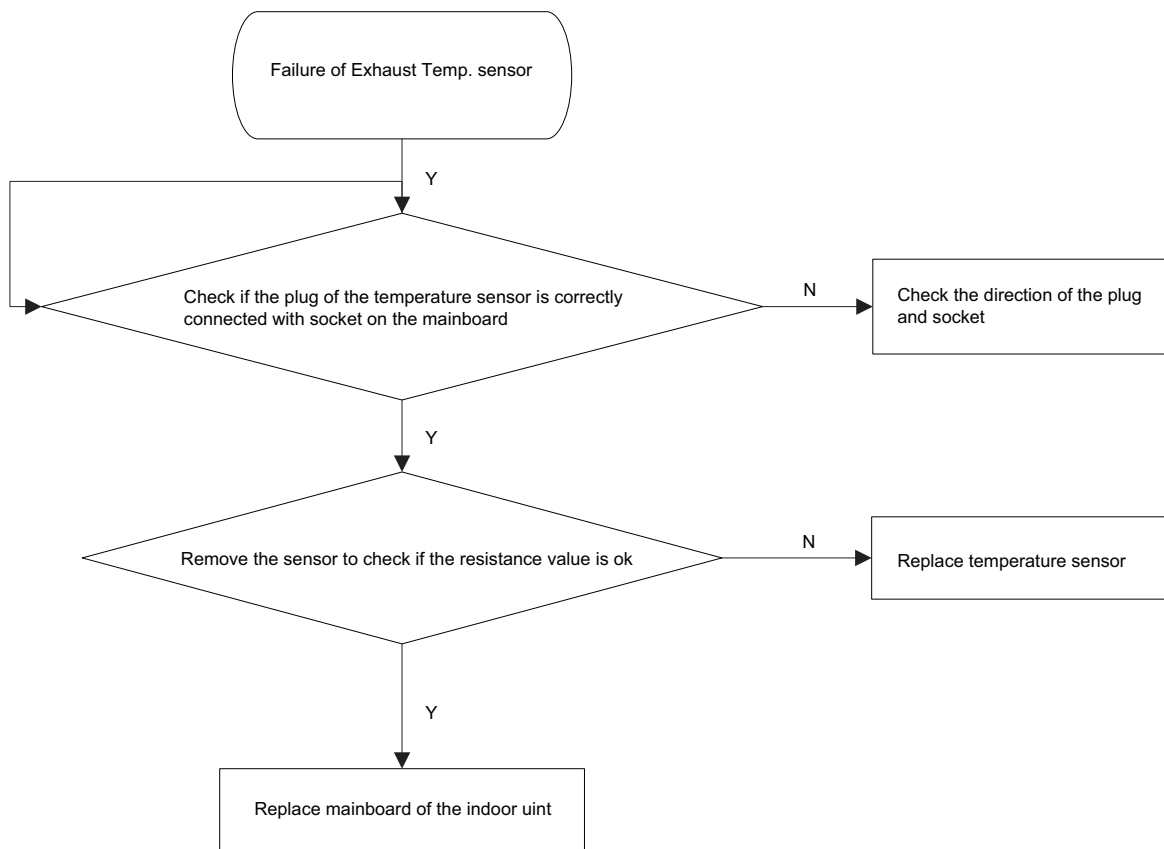

Appendix 1: Resistance Table of Ambient Temperature Sensor for Indoor and Outdoor Units(15K)

Temp(°C)	Resistance(kΩ)	Temp(°C)	Resistance(kΩ)	Temp(°C)	Resistance(kΩ)	Temp(°C)	Resistance(kΩ)
-19	138.1	20	18.75	59	3.848	98	1.071
-18	128.6	21	17.93	60	3.711	99	1.039
-17	121.6	22	17.14	61	3.579	100	1.009
-16	115	23	16.39	62	3.454	101	0.98
-15	108.7	24	15.68	63	3.333	102	0.952
-14	102.9	25	15	64	3.217	103	0.925
-13	97.4	26	14.36	65	3.105	104	0.898
-12	92.22	27	13.74	66	2.998	105	0.873
-11	87.35	28	13.16	67	2.896	106	0.848
-10	82.75	29	12.6	68	2.797	107	0.825
-9	78.43	30	12.07	69	2.702	108	0.802
-8	74.35	31	11.57	70	2.611	109	0.779
-7	70.5	32	11.09	71	2.523	110	0.758
-6	66.88	33	10.63	72	2.439	111	0.737
-5	63.46	34	10.2	73	2.358	112	0.717
-4	60.23	35	9.779	74	2.28	113	0.697
-3	57.18	36	9.382	75	2.206	114	0.678
-2	54.31	37	9.003	76	2.133	115	0.66
-1	51.59	38	8.642	77	2.064	116	0.642
0	49.02	39	8.297	78	1.997	117	0.625
1	46.6	40	7.967	79	1.933	118	0.608
2	44.31	41	7.653	80	1.871	119	0.592
3	42.14	42	7.352	81	1.811	120	0.577
4	40.09	43	7.065	82	1.754	121	0.561
5	38.15	44	6.791	83	1.699	122	0.547
6	36.32	45	6.529	84	1.645	123	0.532
7	34.58	46	6.278	85	1.594	124	0.519
8	32.94	47	6.038	86	1.544	125	0.505
9	31.38	48	5.809	87	1.497	126	0.492
10	29.9	49	5.589	88	1.451	127	0.48
11	28.51	50	5.379	89	1.408	128	0.467
12	27.18	51	5.197	90	1.363	129	0.456
13	25.92	52	4.986	91	1.322	130	0.444
14	24.73	53	4.802	92	1.282	131	0.433
15	23.6	54	4.625	93	1.244	132	0.422
16	22.53	55	4.456	94	1.207	133	0.412
17	21.51	56	4.294	95	1.171	134	0.401
18	20.54	57	4.139	96	1.136	135	0.391
19	19.63	58	3.99	97	1.103	136	0.382

Appendix 2: Resistance Table of Outdoor and Indoor Tube Temperature Sensors(20K)

Temp(°C)	Resistance(kΩ)	Temp(°C)	Resistance(kΩ)	Temp(°C)	Resistance(kΩ)	Temp(°C)	Resistance(kΩ)
-19	181.4	20	25.01	59	5.13	98	1.427
-18	171.4	21	23.9	60	4.948	99	1.386
-17	162.1	22	22.85	61	4.773	100	1.346
-16	153.3	23	21.85	62	4.605	101	1.307
-15	145	24	20.9	63	4.443	102	1.269
-14	137.2	25	20	64	4.289	103	1.233
-13	129.9	26	19.14	65	4.14	104	1.198
-12	123	27	18.13	66	3.998	105	1.164
-11	116.5	28	17.55	67	3.861	106	1.131
-10	110.3	29	16.8	68	3.729	107	1.099
-9	104.6	30	16.1	69	3.603	108	1.069
-8	99.13	31	15.43	70	3.481	109	1.039
-7	94	32	14.79	71	3.364	110	1.01
-6	89.17	33	14.18	72	3.252	111	0.983
-5	84.61	34	13.59	73	3.144	112	0.956
-4	80.31	35	13.04	74	3.04	113	0.93
-3	76.24	36	12.51	75	2.94	114	0.904
-2	72.41	37	12	76	2.844	115	0.88
-1	68.79	38	11.52	77	2.752	116	0.856
0	65.37	39	11.06	78	2.663	117	0.833
1	62.13	40	10.62	79	2.577	118	0.811
2	59.08	41	10.2	80	2.495	119	0.777
3	56.19	42	9.803	81	2.415	120	0.769
4	53.46	43	9.42	82	2.339	121	0.746
5	50.87	44	9.054	83	2.265	122	0.729
6	48.42	45	8.705	84	2.194	123	0.71
7	46.11	46	8.37	85	2.125	124	0.692
8	43.92	47	8.051	86	2.059	125	0.674
9	41.84	48	7.745	87	1.996	126	0.658
10	39.87	49	7.453	88	1.934	127	0.64
11	38.01	50	7.173	89	1.875	128	0.623
12	36.24	51	6.905	90	1.818	129	0.607
13	34.57	52	6.648	91	1.736	130	0.592
14	32.98	53	6.403	92	1.71	131	0.577
15	31.47	54	6.167	93	1.658	132	0.563
16	30.04	55	5.942	94	1.609	133	0.549
17	28.68	56	5.726	95	1.561	134	0.535
18	27.39	57	5.519	96	1.515	135	0.521
19	26.17	58	5.32	97	1.47	136	0.509

Appendix3: Resistance Table for Outdoor Discharge Temperature Sensor (50K)

Temp(°C)	Resistance(kΩ)	Temp(°C)	Resistance(kΩ)	Temp(°C)	Resistance(kΩ)	Temp(°C)	Resistance(kΩ)
-29	853.5	10	98	49	18.34	88	4.75
-28	799.8	11	93.42	50	17.65	89	4.61
-27	750	12	89.07	51	16.99	90	4.47
-26	703.8	13	84.95	52	16.36	91	4.33
-25	660.8	14	81.05	53	15.75	92	4.20
-24	620.8	15	77.35	54	15.17	93	4.08
-23	580.6	16	73.83	55	14.62	94	3.96
-22	548.9	17	70.5	56	14.09	95	3.84
-21	516.6	18	67.34	57	13.58	96	3.73
-20	486.5	19	64.33	58	13.09	97	3.62
-19	458.3	20	61.48	59	12.62	98	3.51
-18	432	21	58.77	60	12.17	99	3.41
-17	407.4	22	56.19	61	11.74	100	3.32
-16	384.5	23	53.74	62	11.32	101	3.22
-15	362.9	24	51.41	63	10.93	102	3.13
-14	342.8	25	49.19	64	10.54	103	3.04
-13	323.9	26	47.08	65	10.18	104	2.96
-12	306.2	27	45.07	66	9.83	105	2.87
-11	289.6	28	43.16	67	9.49	106	2.79
-10	274	29	41.34	68	9.17	107	2.72
-9	259.3	30	39.61	69	8.85	108	2.64
-8	245.6	31	37.96	70	8.56	109	2.57
-7	232.6	32	36.38	71	8.27	110	2.50
-6	220.5	33	34.88	72	7.99	111	2.43
-5	209	34	33.45	73	7.73	112	2.37
-4	198.3	35	32.09	74	7.47	113	2.30
-3	199.1	36	30.79	75	7.22	114	2.24
-2	178.5	37	29.54	76	7.00	115	2.18
-1	169.5	38	28.36	77	6.76	116	2.12
0	161	39	27.23	78	6.54	117	2.07
1	153	40	26.15	79	6.33	118	2.02
2	145.4	41	25.11	80	6.13	119	1.96
3	138.3	42	24.13	81	5.93	120	1.91
4	131.5	43	23.19	82	5.75	121	1.86
5	125.1	44	22.29	83	5.57	122	1.82
6	119.1	45	21.43	84	5.39	123	1.77
7	113.4	46	20.6	85	5.22	124	1.73
8	108	47	19.81	86	5.06	125	1.68
9	102.8	48	19.06	87	4.90	126	1.64

Note: The information above is for reference only.

10. Removal Procedure



Warning

Be sure to wait for a minimum of 10 minutes after turning off all power supplies before disassembly.

(1) Models:GWHD(14)NK3BO,GWHD(18)NK3DO

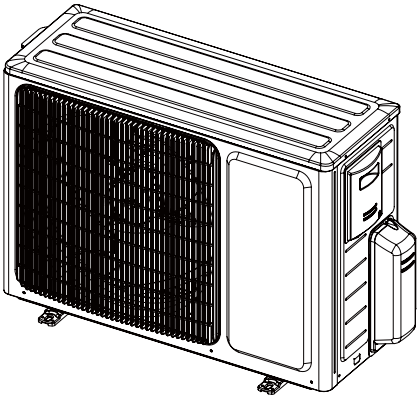
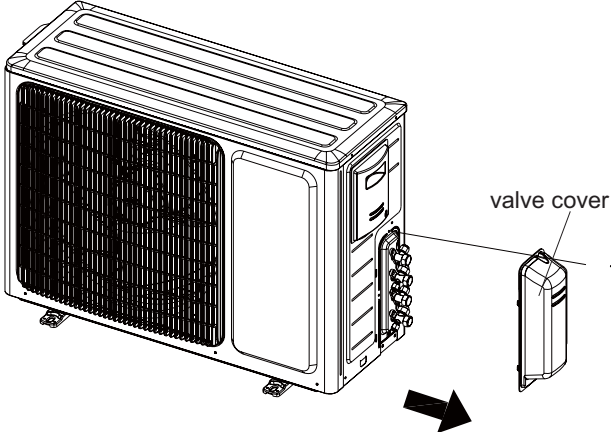
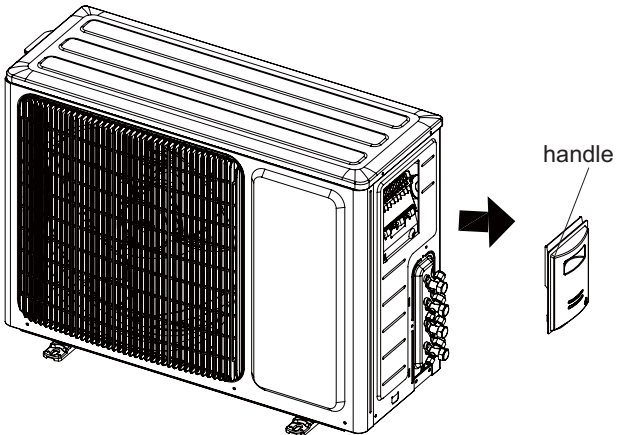
Steps	Procedure
1. Before disassembly	<p data-bbox="225 748 560 779">Complete axonometric drawing.</p> 
2. Remove valve cover	<p data-bbox="225 1229 727 1285">Remove the connection screw fixing the valve cover and then remove the valve cover.</p> 
3. Remove handle	<p data-bbox="225 1747 727 1827">Remove the connection screw fixing the handle and the right side plate, and then remove the handle.</p> 

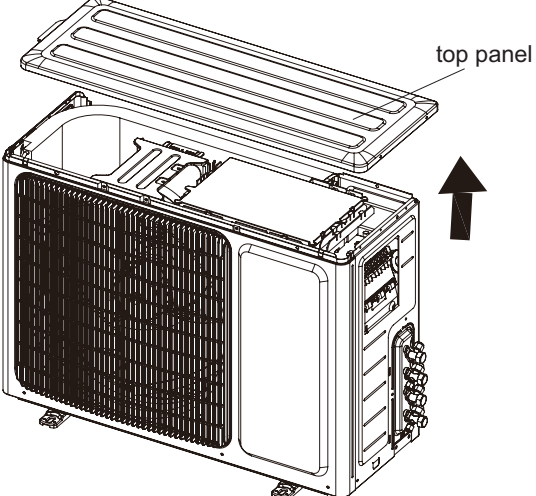
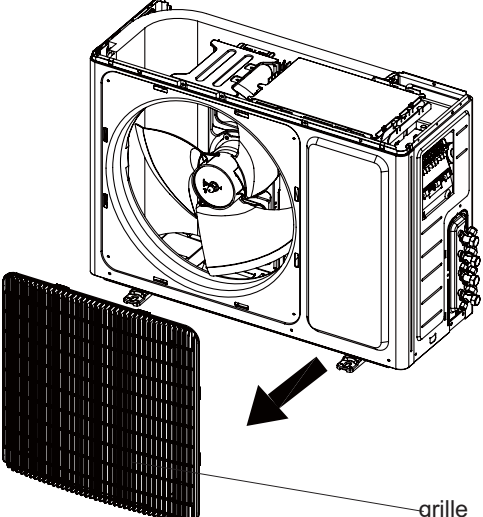
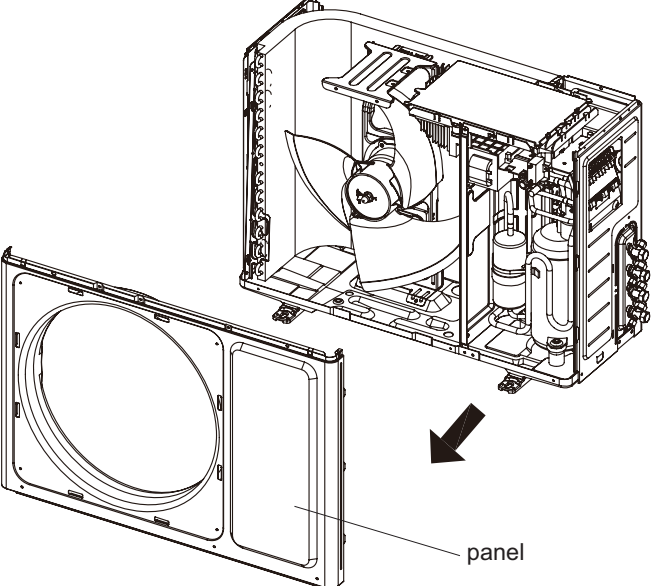
Steps	Procedure
4. Remove top panel	<p data-bbox="220 533 724 645">Remove the connection screws connecting the top panel and the front panel, and then remove the top panel.</p> 
5. Remove front grille	<p data-bbox="220 1032 724 1144">Remove the connection screws connecting the front grille and the front panel, and then loosen the clasp to remove the front grille.</p> 
6. Remove front panel	<p data-bbox="220 1624 724 1691">Remove the screws connecting the front panel and then remove the front panel.</p> 

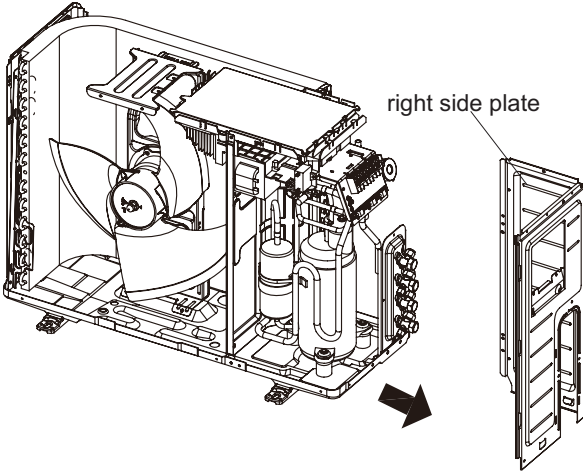
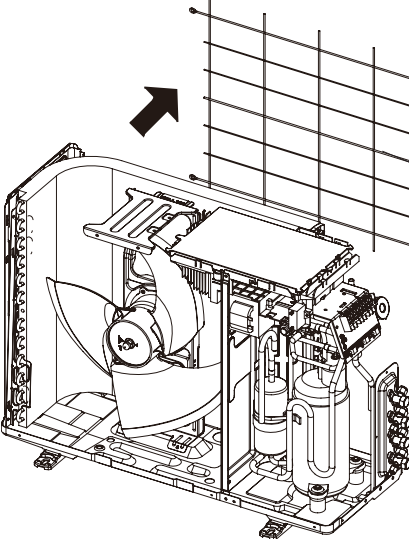
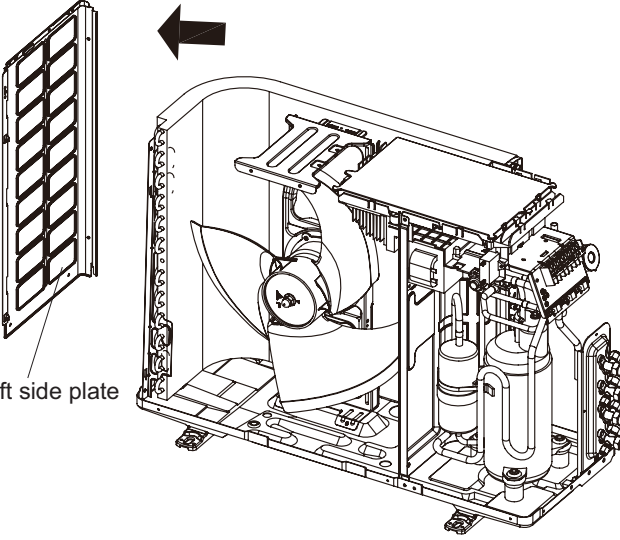
Steps	Procedure
7. Remove right side plate	<p data-bbox="225 517 727 629">Remove the screws connecting the right side plate with the chassis and the valve support. Then remove the right side plate.</p>  <p data-bbox="1286 434 1442 456">right side plate</p>
8. Remove rear grill	<p data-bbox="225 1055 727 1167">Remove the screws connecting the rear grill and left side plate, and then remove the rear grill.</p>  <p data-bbox="1406 1043 1493 1066">rear grill</p>
9. Remove left side plate	<p data-bbox="225 1619 727 1731">Remove the screws fixing the left side plate with the chassis and the condenser support, and then remove the left side plate.</p>  <p data-bbox="839 1816 979 1839">left side plate</p>

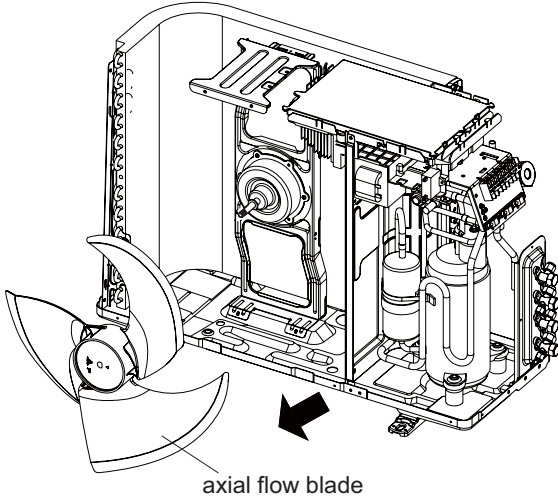
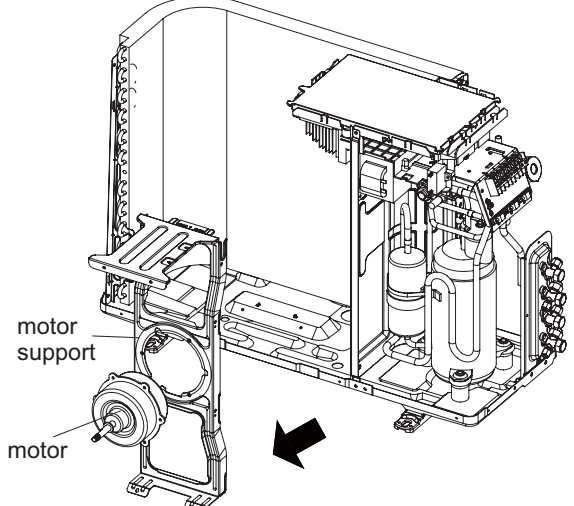
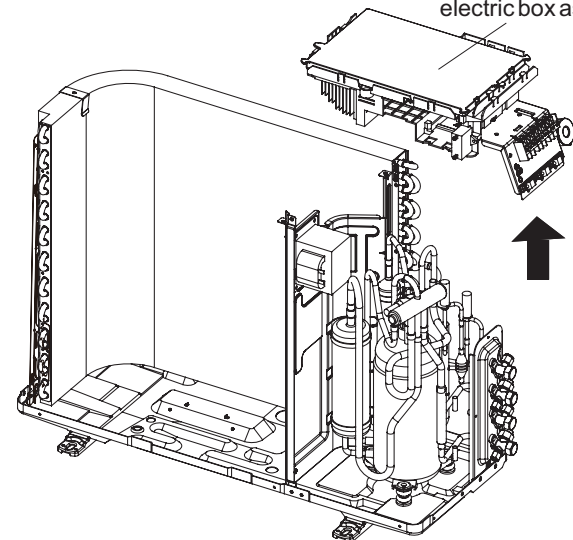
Steps	Procedure
<p>10. Remove axial flow blade</p>	<p>Remove the nut on the blade and then remove the axial flow blade.</p>  <p style="text-align: center;">axial flow blade</p>
<p>11. Remove motor and motor support</p>	<p>Remove the 4 tapping screws fixing the motor and disconnect the leading wire insert of the motor. Then remove the motor. Remove the 2 tapping screws fixing the motor support and chassis, and then lift the motor support to remove it.</p>  <p style="position: absolute; left: 520px; top: 520px;">motor support</p> <p style="position: absolute; left: 520px; top: 570px;">motor</p>
<p>12. Remove electric box assy</p>	<p>Remove the screws fixing the electric box assy and the middle isolation sheet, loosen the wire bundle, unplug the wiring terminals, and then lift the electric box assy to remove it.</p>  <p style="text-align: center;">electric box assy</p>

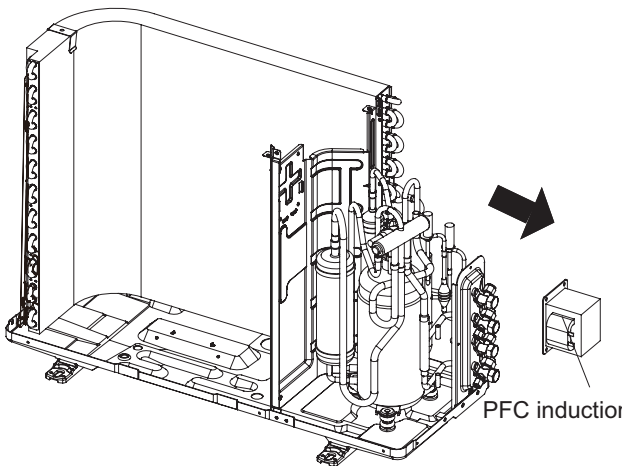
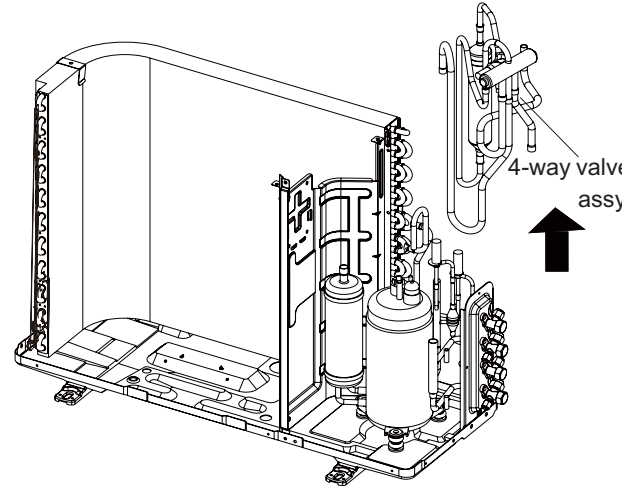
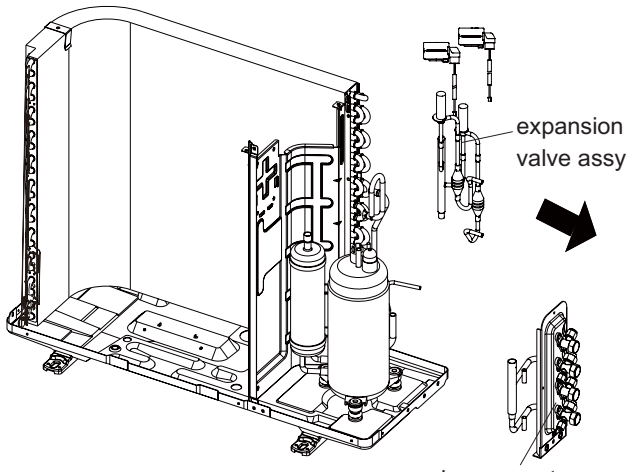
Steps	Procedure
13. Remove PFC induction	 <p>Remove the screw connecting the PFC induction and middle isolation sheet, and then remove the PFC induction.</p>
14. Remove 4-way valve assy	 <p>Unsolder the welding joint connecting the 4-way valve assy with compressor suction and discharge port, the valve with the outlet pipe of condenser. Then lift the 4-way valve assy to remove it. (NOTE: Discharge the refrigerant completely before unsoldering.)</p>
15. Remove valve support sub-assy and expansion valve assy	 <p>Remove the screw connecting the valve support and the chassis, and then remove the valve support assy. Unsolder the welding joint connecting the electronic expansion valve assy with the cut-off valve and the condenser connection pipe, and then remove the expansion valve assy.</p>

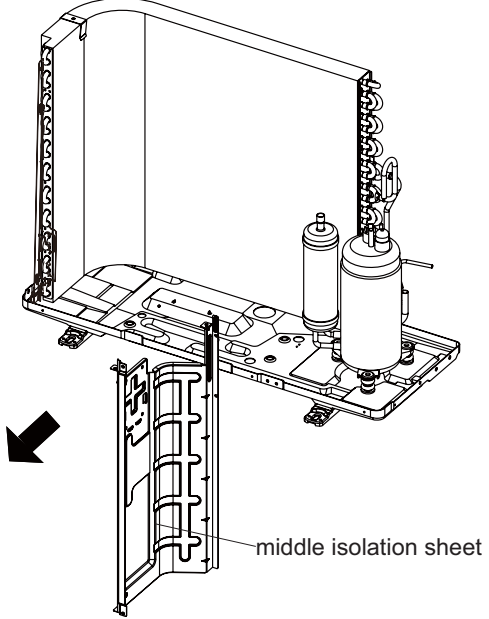
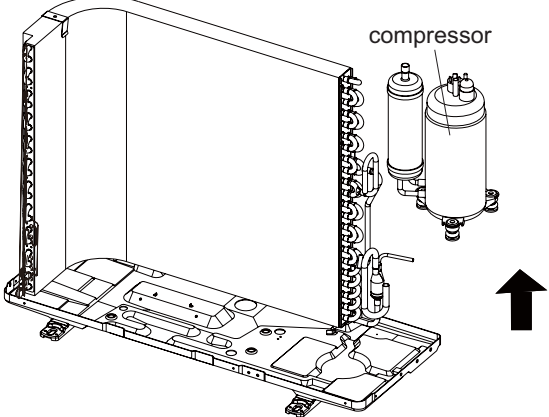
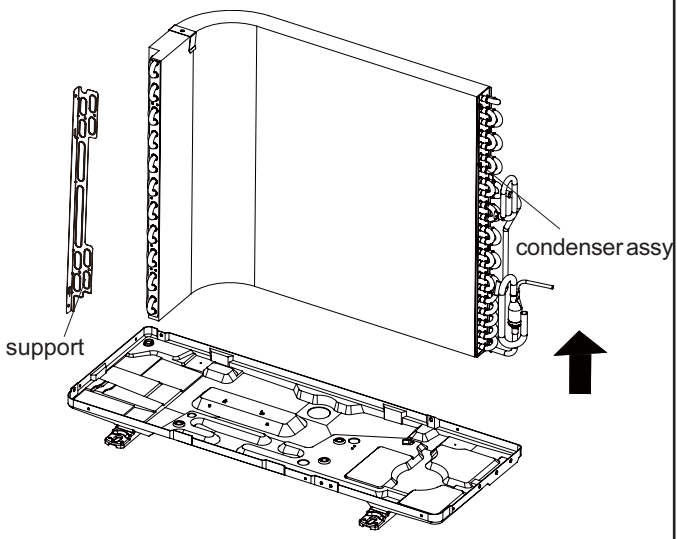
Steps	Procedure
<p>16. Remove middle isolation sheet</p>	<p>Remove the screws connecting the middle isolation sheet with the chassis assy and the condenser assy, and then remove the middle isolation sheet.</p> 
<p>17. Remove compressor</p>	<p>Remove the 3 foot nuts fixing the compressor and then remove the compressor.</p> 
<p>18. Remove condenser assy</p>	<p>Remove the screws fixing the condenser support and then remove the condenser support. Remove the screws connecting the condenser support and the chassis assy, and then remove the condenser assy.</p> 

(2) Model: GWHD(28)NK3BO



Warning

Be sure to wait for a minimum of 10 minutes after turning off all power supplies before disassembly.

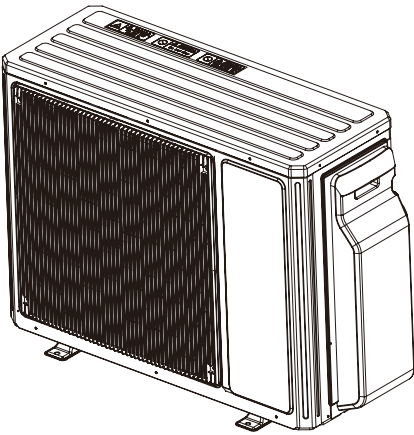
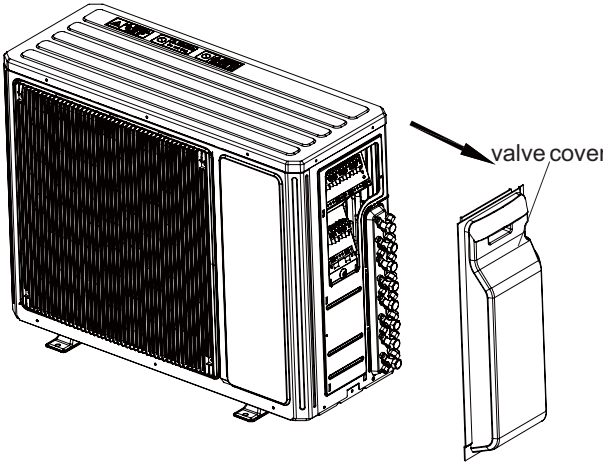
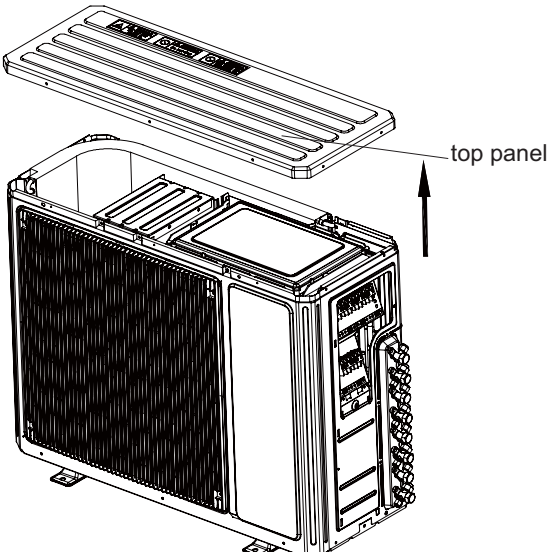
Steps	Procedure
1. Before disassembly	<p>Complete axonometric drawing.</p> 
2. Remove valve cover	<p>Remove the connection screw fixing the valve cover and then remove the valve cover.</p> 
3. Remove top panel	<p>Remove the connection screws connecting the top panel with the right side plate and the left side plate, and then remove the top panel.</p> 

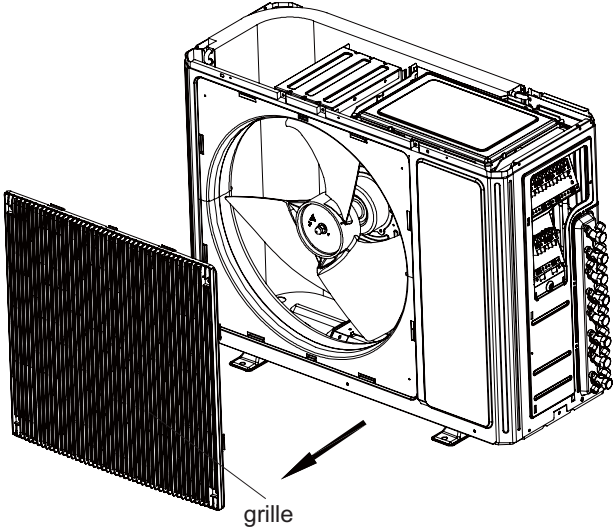
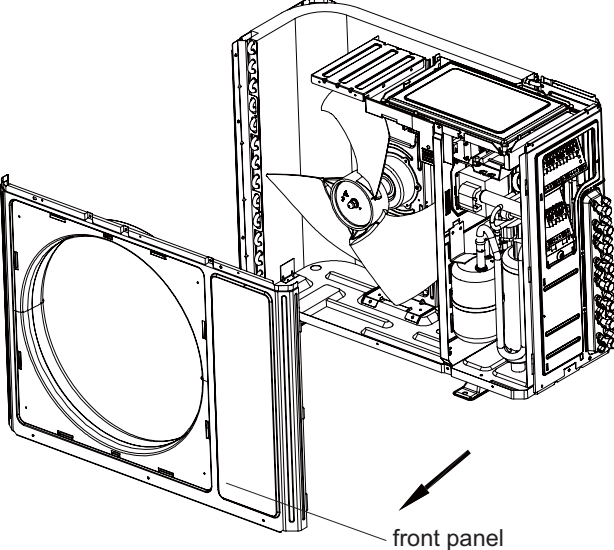
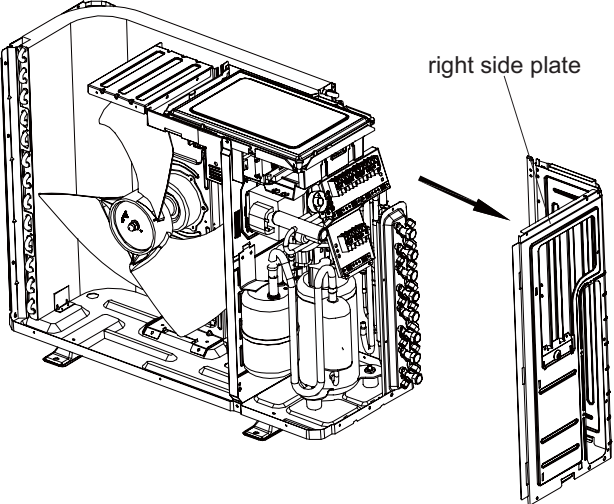
Steps	Procedure
4. Remove front grille	<p data-bbox="225 510 724 613">Remove the connection screws connecting the front grille and the front panel, and then loosen the clasp to remove the front grille.</p> 
5. Remove front panel	<p data-bbox="225 1093 724 1155">Remove the screws connecting the front panel and then remove the front panel.</p> 
6. Remove right side plate	<p data-bbox="225 1715 780 1796">Remove the screws connecting the right side plate with the chassis and the valve support. Then remove the right side plate.</p> 

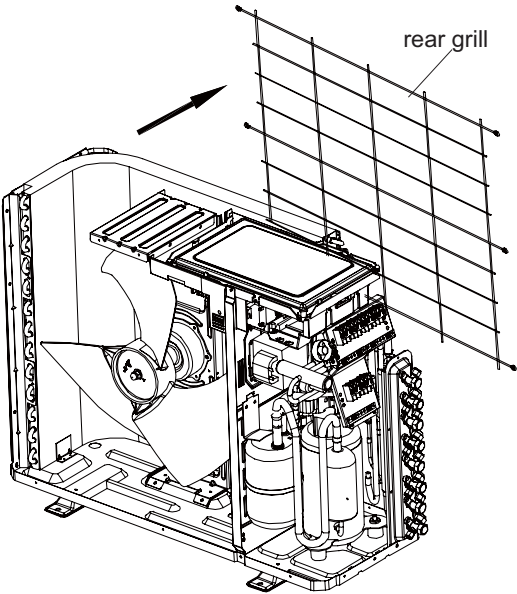
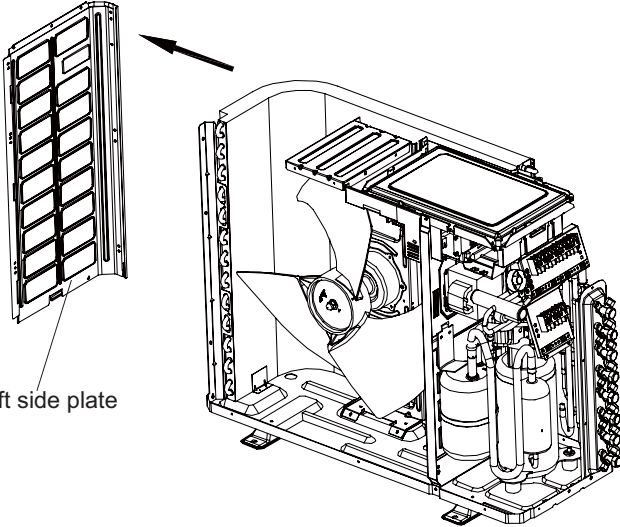
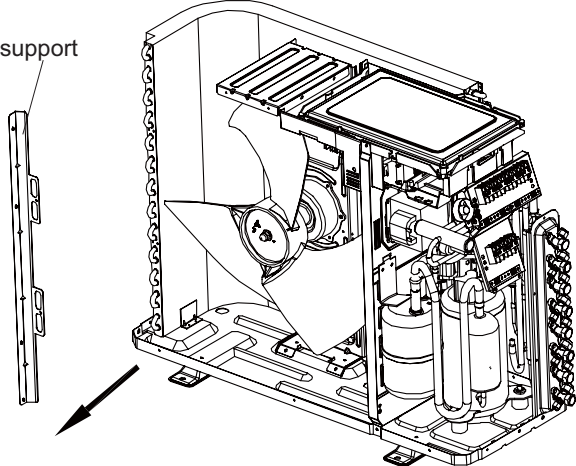
Steps	Procedure	
7. Remove rear grill	Remove the screws connecting the rear grill and the left side plate, and then remove the rear grill.	 <p>Diagram illustrating the removal of the rear grill. The rear grill is shown being lifted away from the unit's chassis. The label 'rear grill' points to the grid structure.</p>
8. Remove left side plate	Remove the screws fixing the left side plate with the chassis and the condenser support, and then remove the left side plate.	 <p>Diagram illustrating the removal of the left side plate. The left side plate is shown being lifted away from the unit's chassis. The label 'left side plate' points to the vertical panel.</p>
9. Remove condenser support	Remove the connection screws connecting the condenser support and the chassis, and then remove the condenser support.	 <p>Diagram illustrating the removal of the condenser support. The condenser support is shown being lifted away from the unit's chassis. The label 'support' points to the vertical panel.</p>

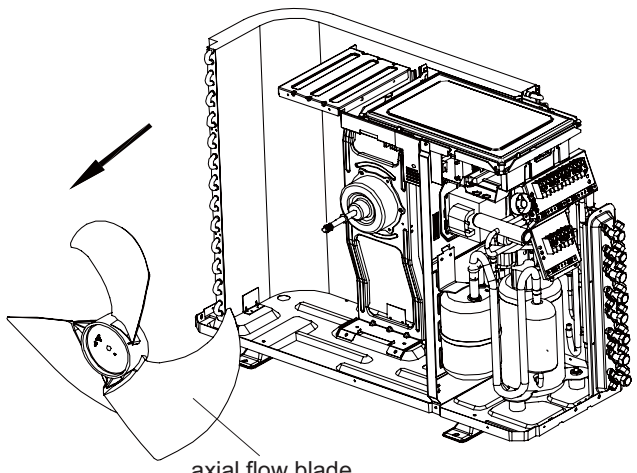
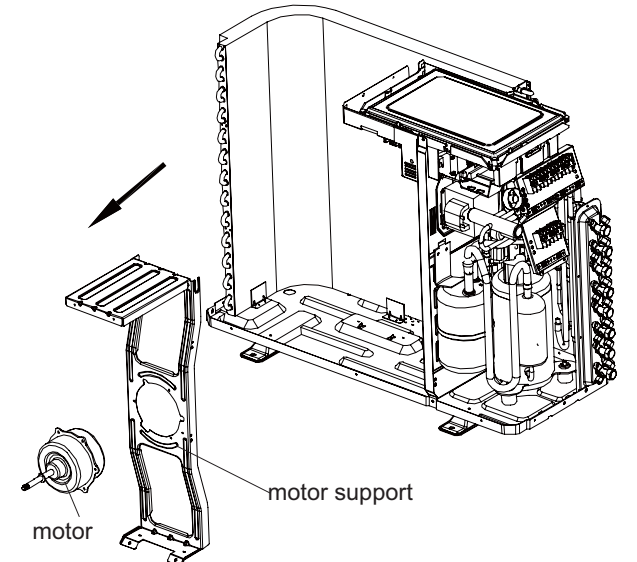
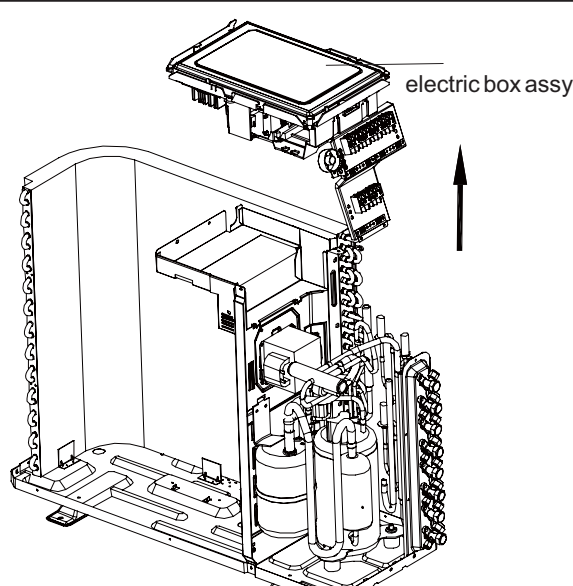
Steps	Procedure
<p>10. Remove axial flow blade</p>	<p>Remove the nut on the blade and then remove the axial flow blade.</p>  <p style="text-align: right;">axial flow blade</p>
<p>11. Remove motor and motor support</p>	<p>Remove the 4 tapping screws fixing the motor and disconnect the leading wire insert of the motor. Then remove the motor. Remove the 2 tapping screws fixing the motor support and chassis, and then lift the motor support to remove it.</p>  <p style="text-align: right;">motor support</p> <p style="text-align: left;">motor</p>
<p>12. Remove electric box assy</p>	<p>Remove the screws fixing the electric box assy and the middle isolation sheet, and then lift the electric box assy to remove it.</p>  <p style="text-align: right;">electric box assy</p>

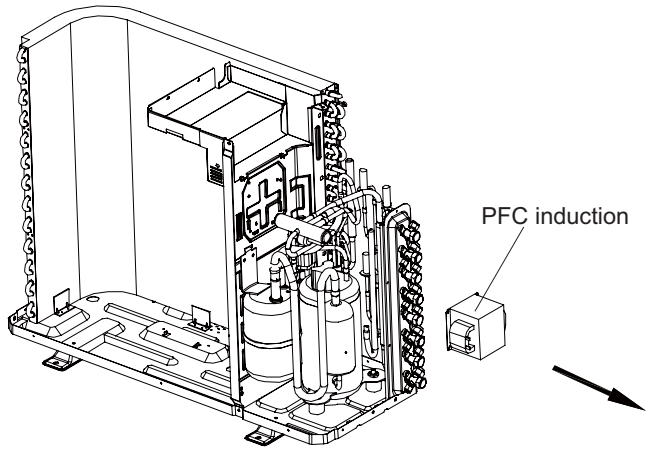
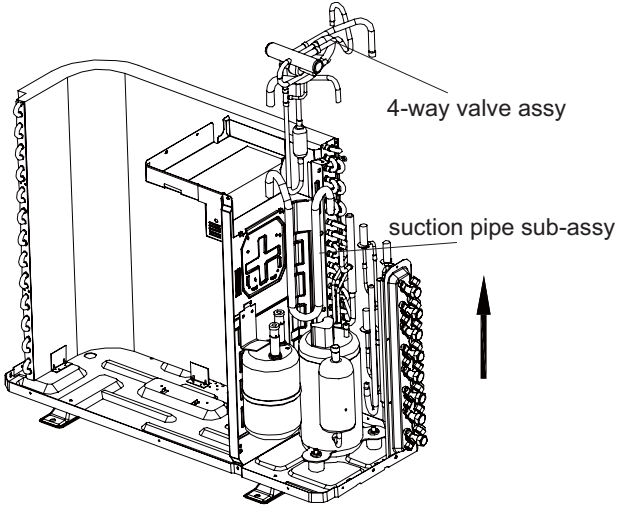
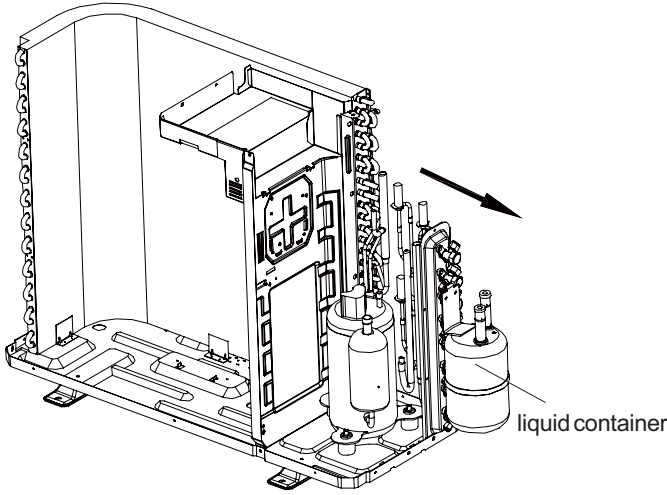
Steps	Procedure
<p>13. Remove PFC induction</p>	<p>Remove the screw connecting the PFC induction and middle isolation sheet, and then remove the PFC induction.</p>  <p>PFC induction</p>
<p>14. Remove 4-way valve assy and suction pipe sub-assy</p>	<p>Unsolder the welding joint connecting the 4-way valve assy with compressor suction and discharge port, the valve with the outlet pipe of condenser. Then lift the 4-way valve assy to remove it. (NOTE: Discharge the refrigerant completely before unsoldering.) Unsolder the welding joint connecting the suction pipe sub-assy with compressor and liquid container, and then remove the suction pipe sub-assy.</p>  <p>4-way valve assy</p> <p>suction pipe sub-assy</p>
<p>15. Remove liquid container</p>	<p>Remove the screws connecting the isolation plate sub-assy and the liquid container, and then lift the liquid container to remove it.</p>  <p>liquid container</p>

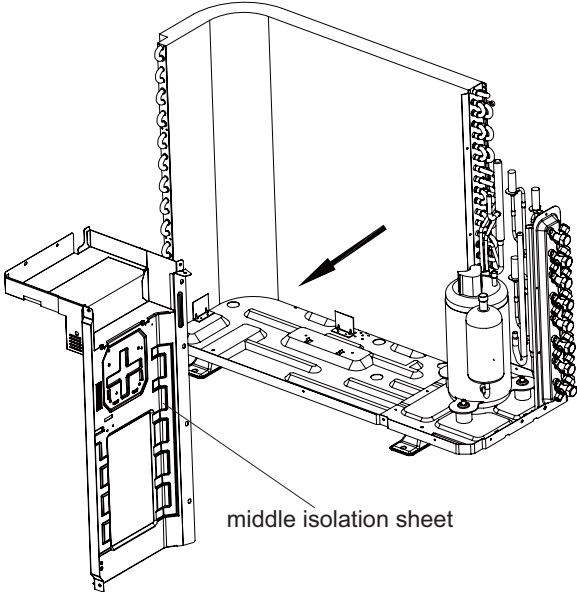
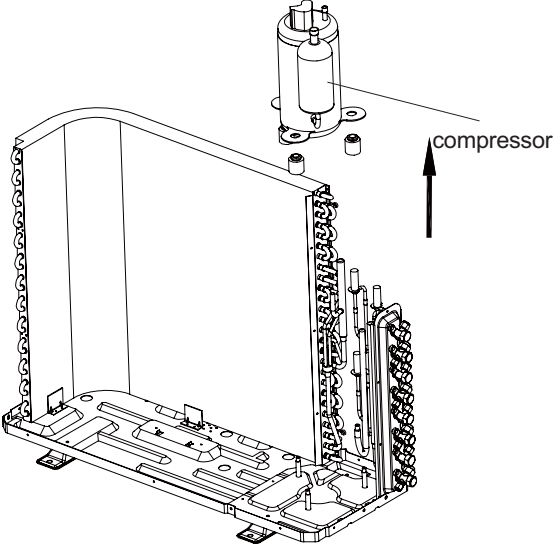
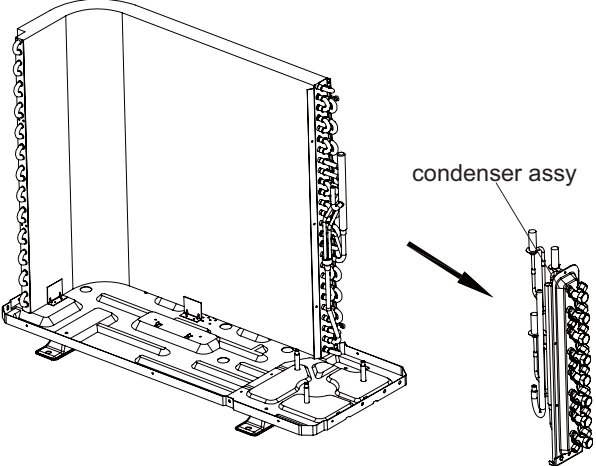
Steps	Procedure
<p>16. Remove middle isolation sheet</p>	<p>Remove the screws connecting the middle isolation sheet with the chassis assy and the condenser assy, and then remove the middle isolation sheet.</p>  <p>middle isolation sheet</p>
<p>17. Remove compressor</p>	<p>Remove the 3 foot nuts fixing the compressor and then remove the compressor.</p>  <p>compressor</p>
<p>18. Remove valve support sub-assy</p>	<p>Remove the screw connecting the valve support assy and the chassis sub-assy, and then remove the valve support assy.</p>  <p>condenser assy</p>

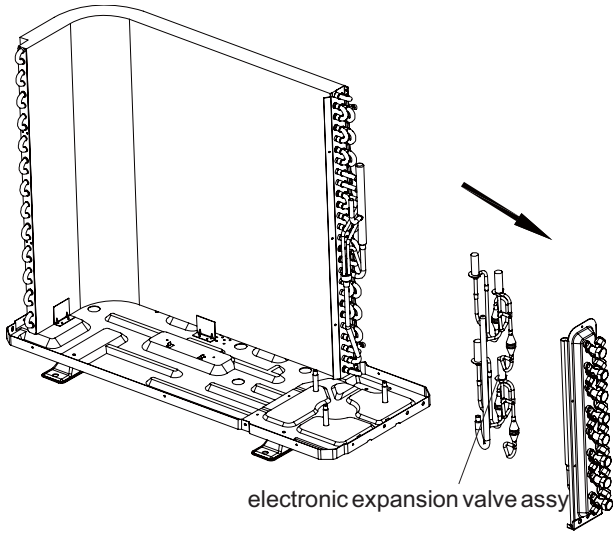
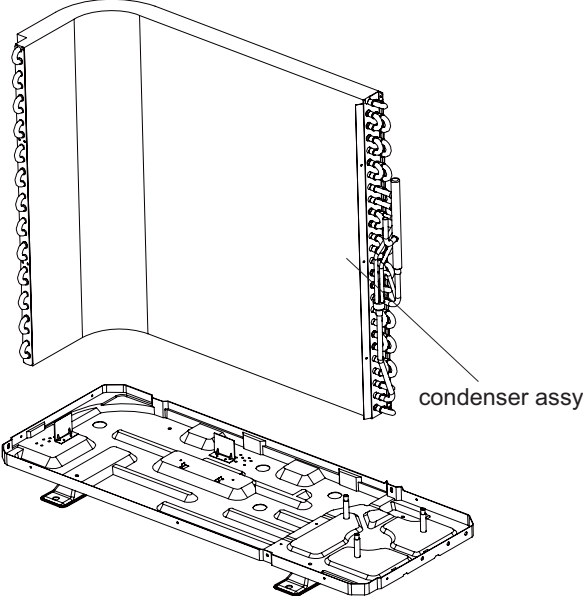
Steps	Procedure
19. Remove electronic expansion valve assy	<p data-bbox="229 510 810 676">Unsolder the welding joint connecting the electronic expansion valve sub-assy with the gas collection pipe, and then remove the electronic expansion valve assy. (Note: when unsoldering, wrap the gas valve with a wet cloth completely to avoid damage to the valve caused by high temperature).</p>  <p data-bbox="1102 824 1426 853">electronic expansion valve assy</p>
20. Remove condenser assy	<p data-bbox="229 1263 735 1346">Remove the screws connecting the condenser assy and the chassis assy, and then remove the condenser assy.</p>  <p data-bbox="1318 1384 1485 1413">condenser assy</p>

(3) Model: GWHD(36)NK3AO, GWHD(42)NK3AO

Warning Be sure to wait for a minimum of 10 minutes after turning off all power supplies before disassembly.

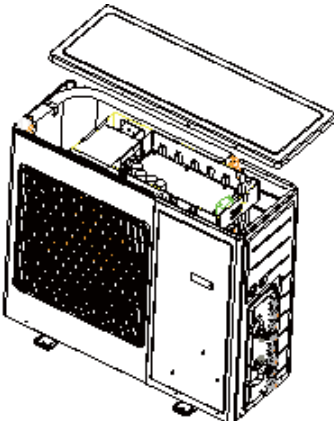
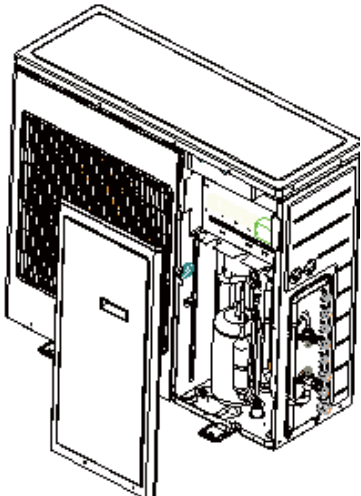
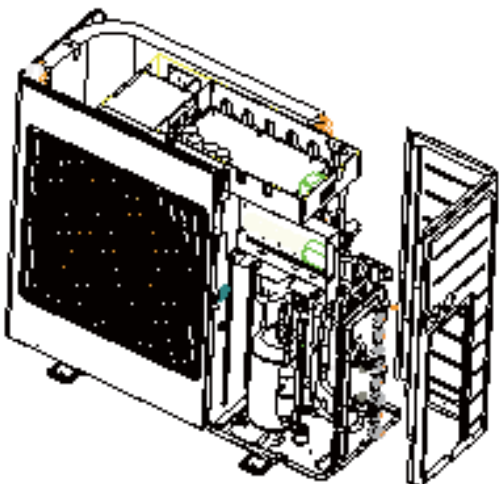
Disassembly and Assembly of Outer Casing	
Steps	Procedure
1. Disassemble the cover plate	
Remove the fixed screws on the cover plate by using a screwdriver. Remove the cover plate.	
2. Disassemble the front panel	
Remove the fixed screws on the front panel by using a screwdriver. Remove the front panel.	
3. Disassemble the panel on the right side	
Remove the fixed screws on the panel by using a screwdriver. Remove the panel on the right side.	

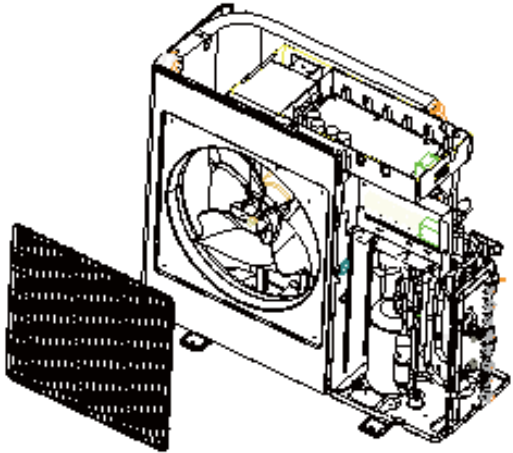
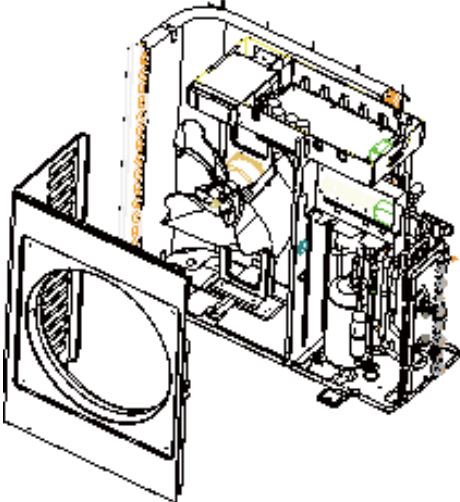
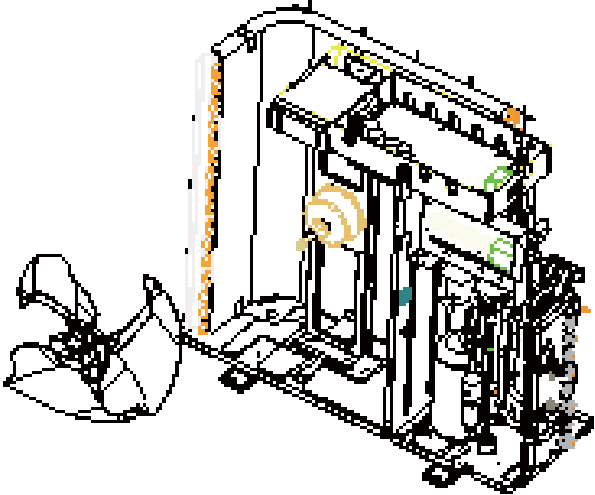
Steps	Procedure
4. Dismount the grille	<p data-bbox="269 562 762 647">Remove the fixed screws on the grille by using a screwdriver. Remove the grille.</p>  An exploded view diagram of a fan assembly. The fan housing is shown on the right, and the black grille is shown on the left, separated from the housing. The grille has a grid pattern. The fan housing has a circular opening for the fan blades.
5. Disassemble the outer casing	<p data-bbox="269 1128 778 1214">Remove the fixed screws on the outer casing by using a screwdriver. Remove the outer casing.</p>  An exploded view diagram of a fan assembly. The fan housing is shown on the right, and the outer casing is shown on the left, separated from the housing. The outer casing has a circular opening for the fan blades.
6. Disassemble the fan blades	<p data-bbox="269 1720 761 1805">Remove the fixed screws on the fan blades by using a spanner. Remove the fan blades.</p>  An exploded view diagram of a fan assembly. The fan housing is shown on the right, and the fan blades are shown on the left, separated from the housing. The fan blades are three-bladed and have a curved shape.

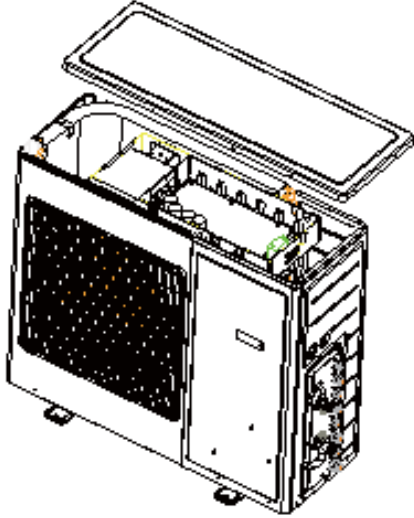
Steps	Procedure
7. Assemble the disassembled main parts as per the reverse disassembly order mentioned above	
	<p>Assemble the disassembled main parts as per the reverse disassembly order mentioned above and energize the unit for trial test.</p> 

Disassembly and Assembly of Compressor

Remark: Make sure that there is no refrigerant in pipe system and the power supply is cut off before disassembling the compressor.

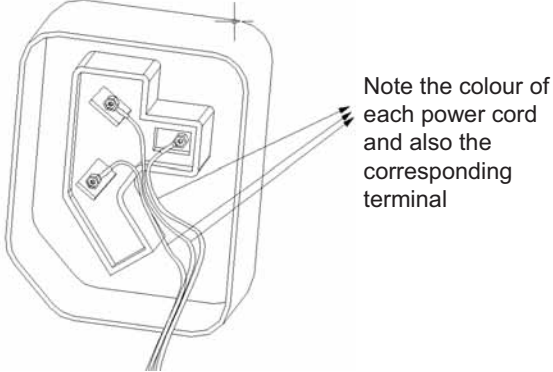
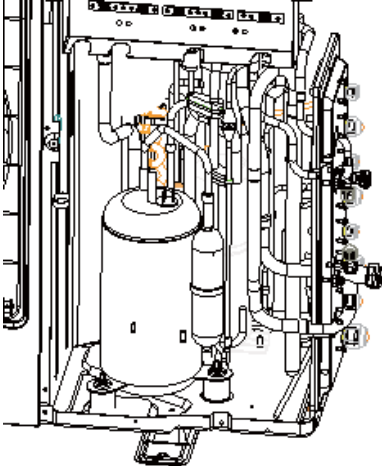

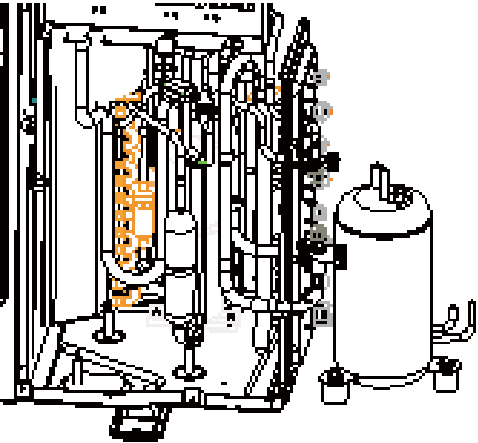
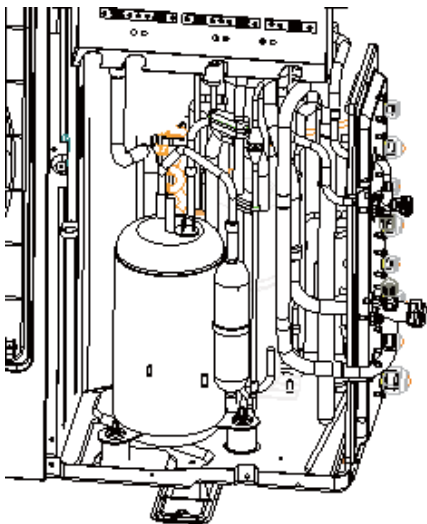
Steps	Procedure
1. Disconnect the power cord	
	<p>Remove the fixed screws on the power cord by using a screwdriver. Draw out the power cord;</p> <p>Note: Please note the color of each power cord and also the corresponding terminal number when removing the power cord in case of misconnection.</p> 
2. Disassemble the pipeline connected with compressor	
	<p>Disconnect the pipeline connected with compressor.</p> 

Steps	Procedure	
3. Take down the bad compressor	<p>Remove the bolts on the compressor by using a tool. Take down the bad compressor from the bottom plate.</p>	
4. Place the new compressor on the bottom plate and connect the suction inlet and discharge outlet with the pipe system	<p>Place the compressor on the bottom plate. Tighten the nuts by using a tool.</p>	

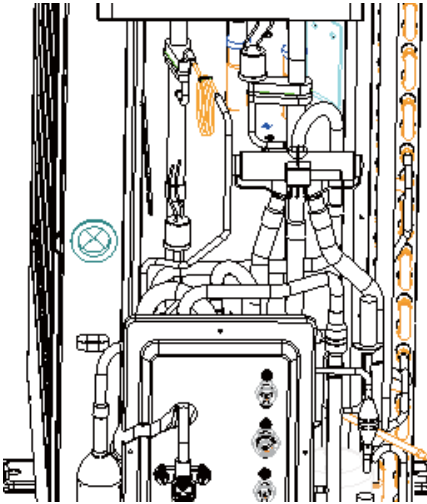
Disassembly and Assembly of 4-way Valve

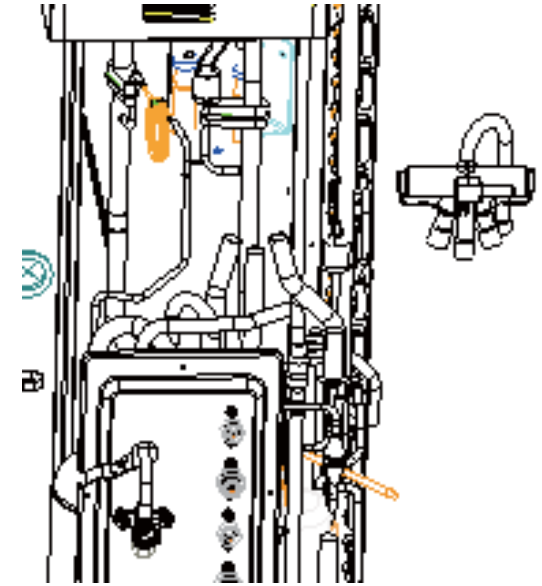
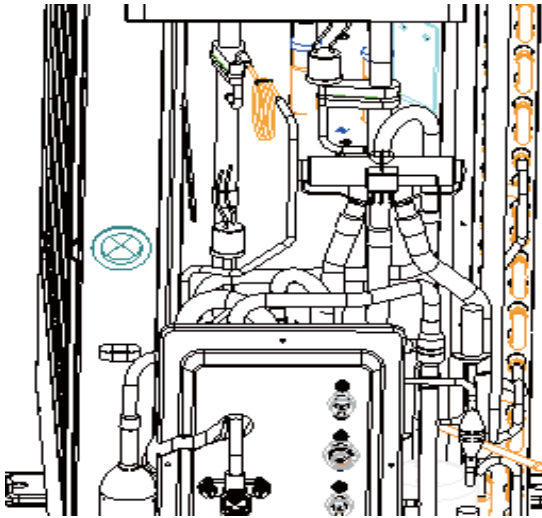
Steps	Procedure	
1. Remove the 4-way valve coil	<p>Remove the screws on the fixed coil by using a screwdriver. Remove the 4-way valve coil.</p>	

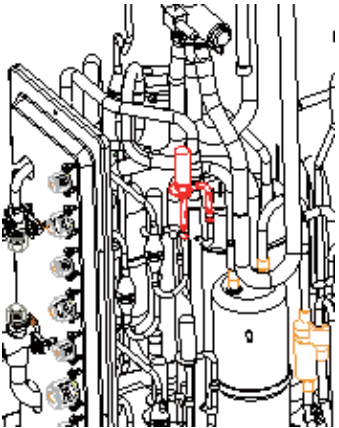
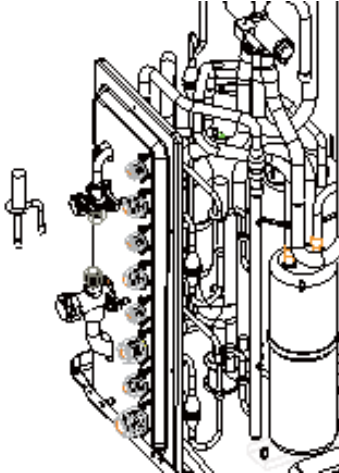
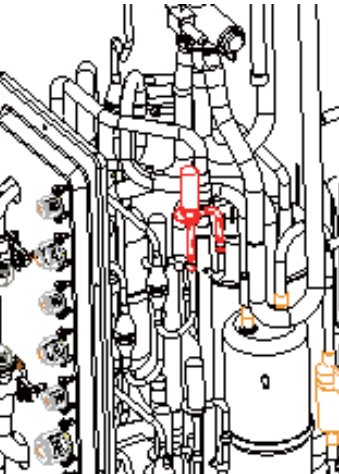
Steps	Procedure
<p>2. Disconnect the 4-way valve and the connected pipe by soldering. Take down the bad 4-way valve.</p>	<p>Disconnect the 4-way valve and the connected pipe by a welding gun. Take down the bad 4-way valve.</p> 
<p>3. Replace the 4-way valve and reconnect it with the pipeline.</p>	<p>Place the new 4-way valve in the right place. Rewelding the new 4-way valve with the pipeline.</p> 
<p>4. Install the 4-way valve coil</p>	<p>Set the 4-way valve coil soundly. Tighten the screws by a screwdriver.</p>

Disassembly and Assembly of Electronic Expansion Valve	
Steps	Procedure
1. Remove the electronic expansion valve coil	
Remove the electronic expansion valve coil by rotating it until the lock is unfixed.	
2. Disconnect the electronic expansion valve and the connected pipe by soldering	
Disconnect the electronic expansion valve and the connected pipe by a welding gun.	
3. Replace the electronic expansion valve	
Place the new electronic expansion valve in the right place.	
4. Reconnect the electronic expansion valve with the pipeline	
Reconnect the electronic expansion valve with the pipeline by welding.	
5. Install the electronic expansion valve coil	
Set the electronic expansion valve coil on the valve body and adjust the lock to the right place.	

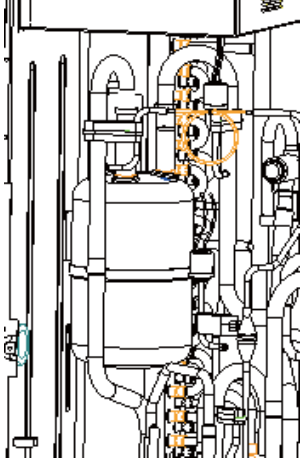
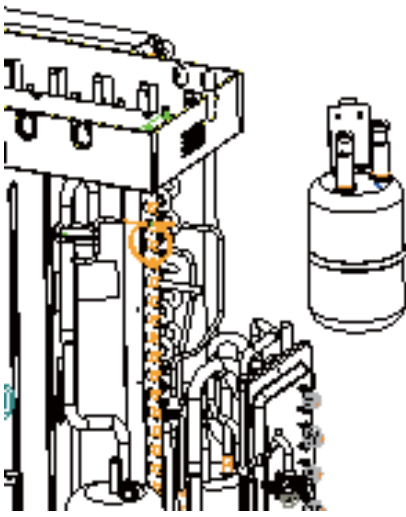
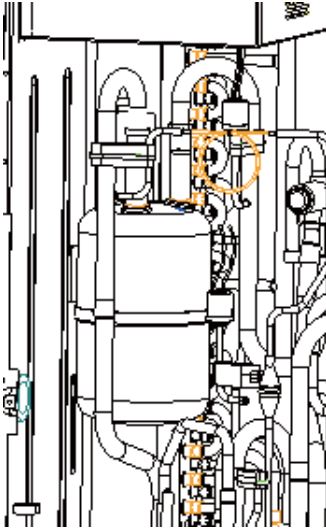
Disassembly and Assembly of Vapour Liquid Separator	
Steps	Procedure
1. Disconnect the liquid separator and the connected pipeline	
Disconnect the liquid separator and the connected pipeline.	
2. Remove the liquid separator	
Remove the bolt fixing the liquid separator by a tool. Remove the liquid separator from the middle baffle.	
3. Fix the new liquid separator and connect it with the pipeline	
Fix the new liquid separator on the middle baffle soundly. Tighten the bolt by tool and reconnect the new liquid separator with the pipeline by welding.	

JF00300826

GREE ELECTRIC APPLIANCES, INC. OF ZHUHAI

Add: West Jinji Rd, Qianshan, Zhuhai, Guangdong, China, 519070

Tel: (+86-756) 8522218 Fax: (+86-756) 8669426

E-mail: gree@gree.com.cn www.gree.com

For continuous improvement in the products, Gree reserves the right to modify the product specification and appearance in this manual without notice and without incurring any obligations.