

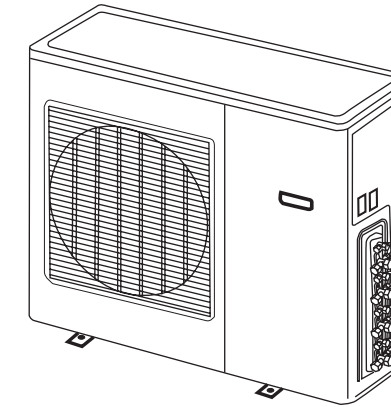

Please read this owner's manual carefully before operating, and keep it carefully for reference.

Split Air Conditioner Wall Mounted Model
(INVERTER)



OWNER'S MANUAL

© GREE 66163039

OWNER'S MANUAL

GWHD(24)NK3CO
GWHD(28)NK3AO

In line with the company's policy of continual product improvement, the aesthetic and dimensional characteristics, technical data and accessories of this appliance may be changed without notice.

CONTENTS

GENERAL INFORMATION

GENERAL INFORMATION	Conformity And Range	1
	The Instructions Befor Use	2
	Name Of The Parts	3
	Technical Data	3
	Outdoor Unit Working Temperature Range	3
INSTALLER	Electrical Connections	4
	Installing The Outdoor Unit	6
	Bleeding	6
	Maintenance	7
	Installation Dimension Diagram	7
	Check After Installation	8
	Fault Indication	9
	ALLOCATION	10

CONFORMITY AND RANGE

GENERAL INFORMATION

The air conditioner you have purchased is in conformity with the following European Directives:

- Low Voltage 73/23/EEC
- Electromagnetic compatibility 89/336/EEC



 Please read this owner's manual carefully before operating the unit and keep it carefully for consultation.

 Only use the air conditioner as instructed in this booklet. These instructions are not intended to cover every possible condition and situation. As with any electrical household appliance, common sense and caution are therefore always recommended for installation, operation and maintenance.

WARNING

★ When having a burning smell or smoke, please turn off the power supply and contact with the service center .

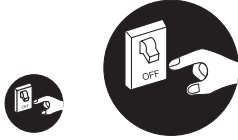

If the abnormality still exists, the unit may be damaged, and may cause electric shock or fire.

★ The power supply must adopt the special circuit that with air switch protection and assure it has enough capacity. The unit will be turned on or off according to your requirement automatically, please do not turn on or turn off the unit frequently, otherwise disadvantage effect may be caused to the unit.

★ Never cut off or damage power cables and control wires. If the power cable and signal control wire were damaged, change them by professional



★ Power must adopts the special circuit to prevent fire.

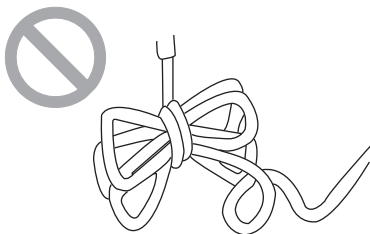

Otherwise, it can cause electric shock or fire.

★ Disconnect the power supply if long putting the air conditioner out of use.



Otherwise, the accumulated dusts may cause overheating or fire.

★ Never damage the electric wire or use the electric wire which is not appointed.



Otherwise, it will cause overheating or fire.

★ When cleaning, it is necessary to stop driving and turn off the power supply.

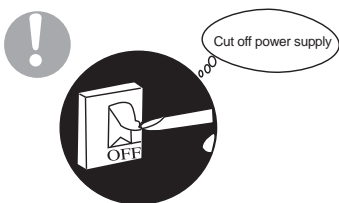

Otherwise, it may cause electric shock or damage.

★ Rated voltage of this airconditioner 220-240V~50Hz, The compressor will vibrate sharply if the voltage is too low, resulting in damage to refrigerating system. Electrical component are easy to damage if the voltage is too high.



★ Don't attempt to repair the air conditioner by yourself.

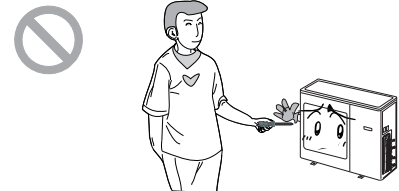

The wrong repair will lead to an electric shock or fire, so you should contact the service center to repair.

★ Please note whether the installed stand is firm enough or not.

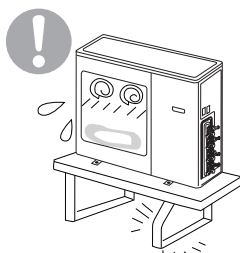

If it is damaged, it may lead to the fall of the unit and cause the injury.

★ Don't step on the top of the outdoor unit or place something on it.

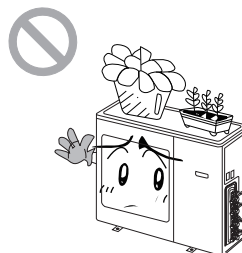

As falling off the outdoor unit can be dangerous.

★ Earthing: The unit must be reliably earthed. The earthing cable shall be connected to the special earthing device in the construction.



Warning

- Be sure to cut off the power supply before cleaning the air conditioner; otherwise electric shock might happen.
- Wetting of air conditioner may cause the risk of electric shock. Make sure not to wash your air conditioner in any case.
- Volatile liquids such as thinner or gasoline will cause damage to the appearance of air conditioner. (Only use soft dry cloth moist cloth clean the air conditioner cabinet).
- This product must not be disposed together with the domestic waste. This product has to be disposed at an authorized place for recycling of electrical and electronic appliances.
- The temperature of refrigerant circuit will be high, please keep the interconnection cable away from the copper tube.



OUTDOOR UNIT	
No.	Description
1	Air outlet grille
2	Valve

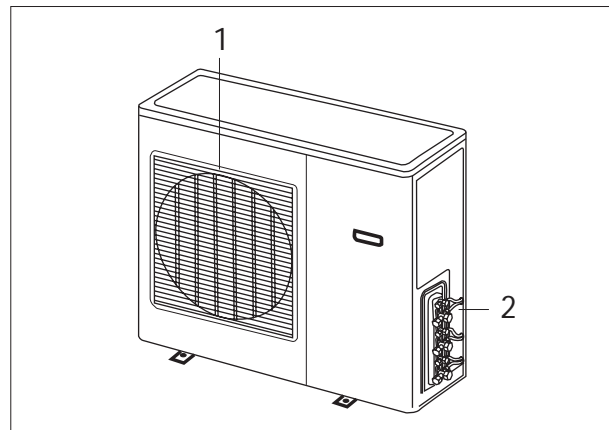
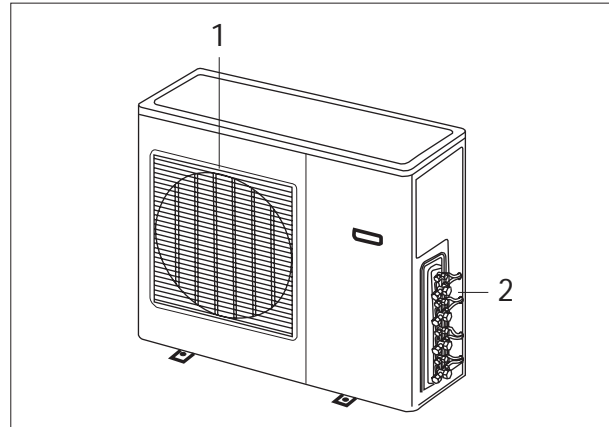

Note: the above figures are only intended to be a simple diagram of the appliance and may not correspond to the appearance of the units that have been purchased.

TECHNICAL DATA

GENERAL INFORMATION

Electrical data			
Electricity supply		220-240V ~50	V ~Hz
Fuse or air switch		30	A
Minimum power cord section		4.0	mm ²
Refrigerant gas		R410 A	
Size and clearance			
	MOD	GWHD(28)NK3AO	GWHD(24)NK3CO
	L	950	mm
	W	420	mm
	H	840	mm

OUTDOOR UNIT WORKING TEMPERATURE RANGE

GENERAL INFORMATION

	Outdoor side DB/WB(°C)
Maximum cooling	43/26(T1)
Minimum cooling	21/-
Maximum heating	24/18
Minimum heating	-5/-6

GWHD(24)NK3CO:

1. Remove the handle at the right side plate of the outdoor unit (one screw).
2. Remove the cable clamp, connect the power connection cable with the terminal at the row of connection and fix the connection. The fitting line distributing must be consistent with the indoor unit. terminal of line bank. Wiring should meet that of indoor unit.
3. Fix power connection wire by wire clamp.
4. Ensure wire has been fixed well.
5. Install the handle.



- An all-pole disconnection switch having a contact separation of at least 3mm in all pole should be connected in fixed wiring.
- Wrong wire connection may cause malfunction of some electric components. After fixing cable, ensure that leads between connection to fixed point have some space.
- The connection pipes and the connecting wirings of the unit A and unit B must be corresponding to each other respective.
- The appliance shall be installed in accordance with national wiring regulations.
- Do not install the outdoor unit where it is exposed to the sunlight.

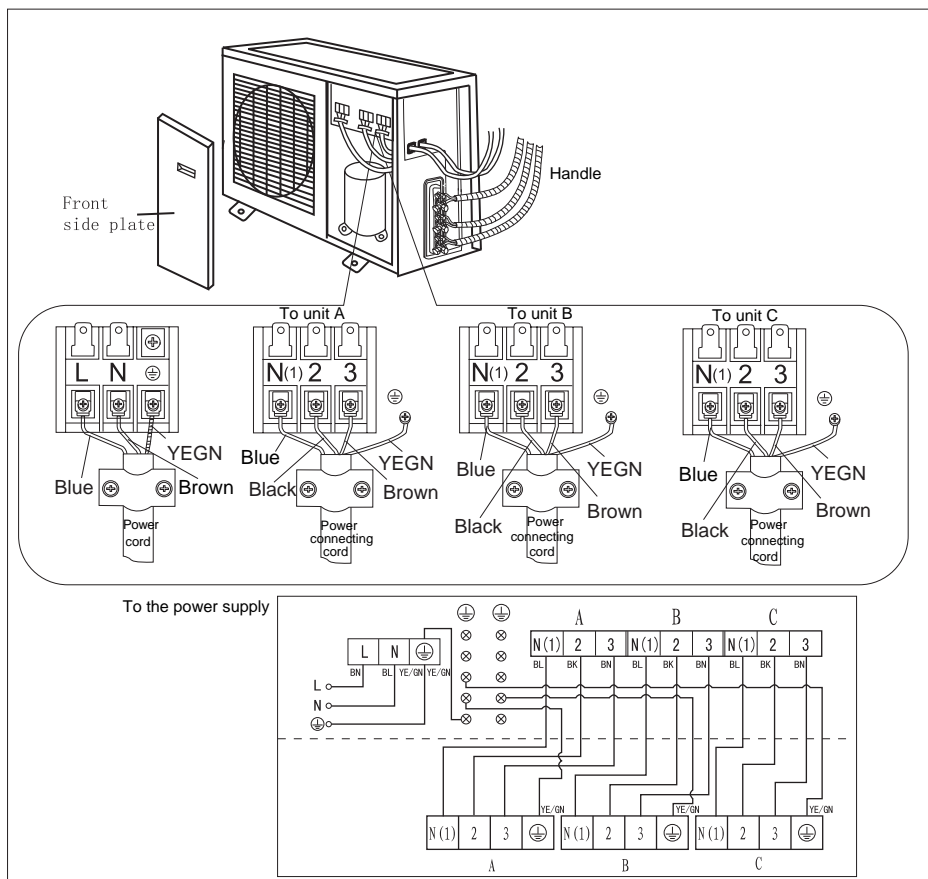

G W H D (2 8) N K 3 A O :

1. Remove the handle at the right side plate of the outdoor unit (one screw).
2. Remove the cable clamp, connect the power connection cable with the terminal at the row of connection and fix the connection. The fitting line distributing must be consistent with the indoor unit. terminal of line bank. Wiring should meet that of indoor unit.
3. Fix power connection wire by wire clamp.
4. Ensure wire has been fixed well.
5. Install the handle.



- An all-pole disconnection switch having a contact separation of at least 3mm in all pole should be connected in fixed wiring.
- Wrong wire connection may cause malfunction of some electric components. After fixing cable, ensure that leads between connection to fixed point have some space.
- The connection pipes and the connecting wirings of the unit A and unit B must be corresponding to each other respective.
- The appliance shall be installed in accordance with national wiring regulations.
- Do not install the outdoor unit where it is exposed to the sunlight.

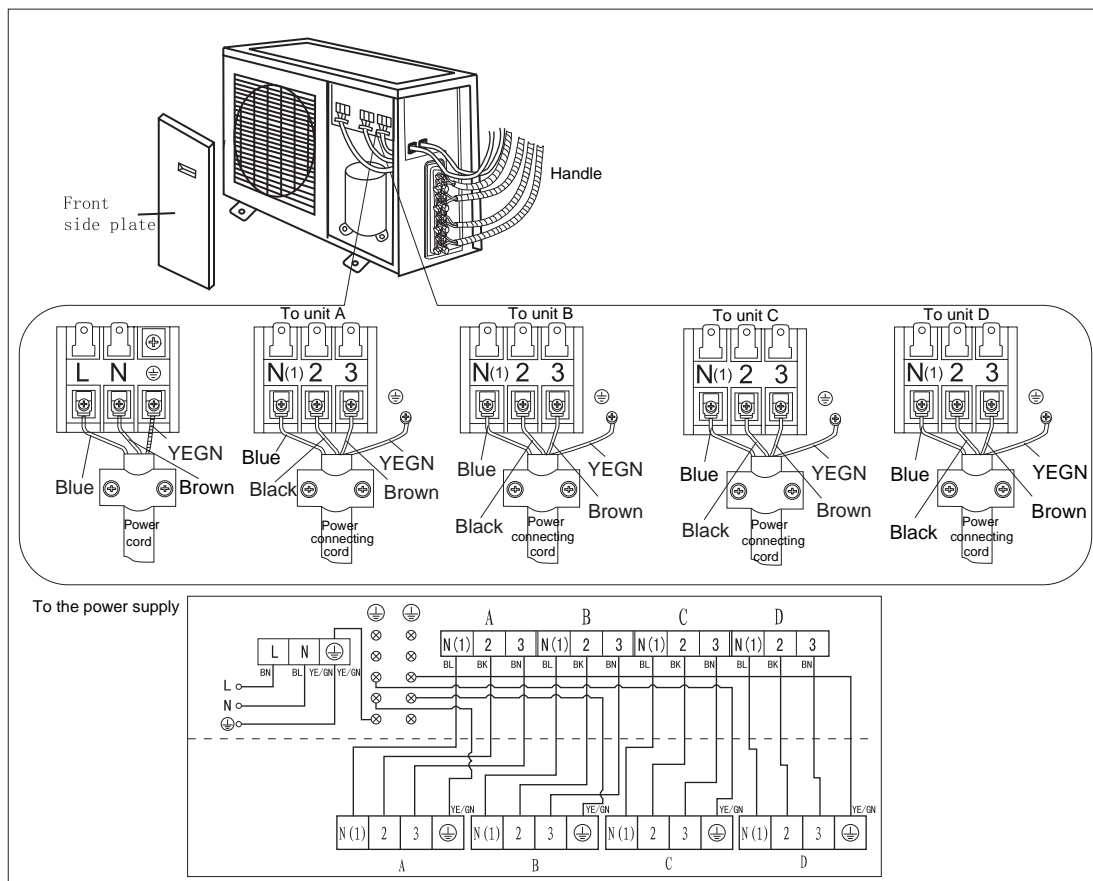

HANDLING

- After having removed the packaging, check that the contents are intact and complete.
- The outdoor unit must always be kept upright.

USER

- Handling must be done by suitably equipped qualified technical personnel using equipment that is suitable for the weight of the appliance.

Location

! Use bolts to secure the unit to a flat, solid floor. When mounting the unit on a wall or the roof, make sure the support is firmly secured so that it cannot move in the event of intense vibrations or a strong wind.

● Do not install the outdoor unit in pits or air vents

Installing the pipes

! Use suitable connecting pipes and equipment for the refrigerant R410A.

! The refrigerant pipes must not exceed the maximum lengths .

! Lag all the refrigerant pipes and joints.

! Tighten the connections using two wrenches working in opposite directions.

Install the drain fitting and the drain hose (for model with heat pump only)

Condensation is produced and flows from the outdoor unit when the appliance is operating in the heating mode. In order not to disturb neighbours and to respect the environment, install a drain fitting and a drain hose to channel the condensate water. Install the drain fitting and rubber washer on the outdoor unit chassis and connect a drain hose to it as shown in the figure.

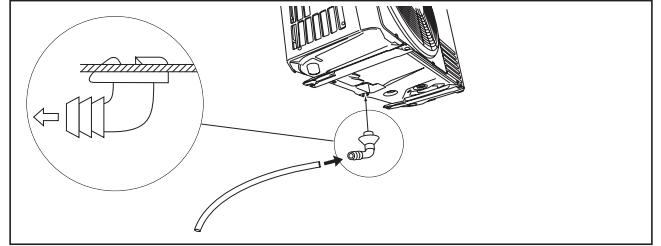

BLEEDING

INSTALLER

Humid air left inside the refrigerant circuit can cause compressor malfunction. After having connected the indoor and outdoor units, bleed the air and humidity from the refrigerant circuit using a vacuum pump.

- (1) Unscrew and remove the caps from the 2-way and 3-way valves.
- (2) Unscrew and remove the cap from the service valve.
- (3) Connect the vacuum pump hose to the service valve.
- (4) Operate the vacuum pump for 10-15 minutes until an absolute vacuum of 10 mm Hg has been reached.
- (5) With the vacuum pump still in operation, close the low-pressure knob on the vacuum pump coupling. Stop the vacuum pump.
- (6) Open the 2-way valve by 1/4 turn and then close it after 10 seconds. Check all the joints for leaks using liquid soap or an electronic leak device.
- (7) Turn the body of the 2-way and 3-way valves. Disconnect the vacuum pump hose.
- (8) Replace and tighten all the caps on the valves.

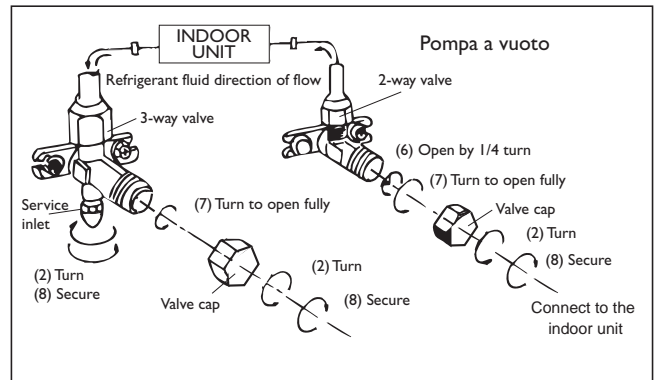
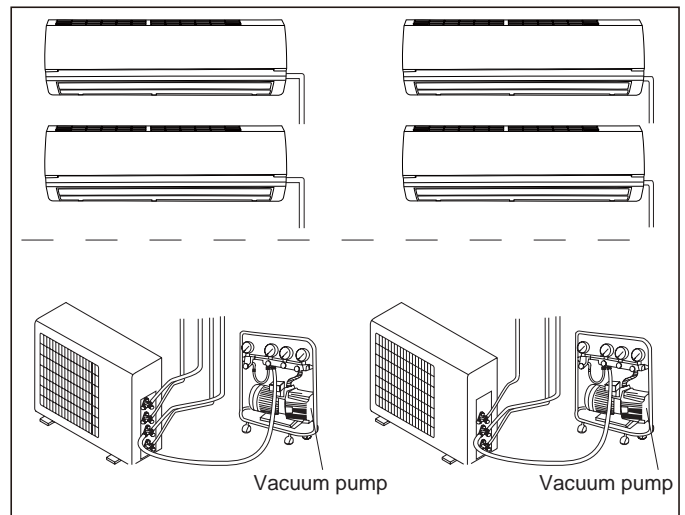

Diameter (mm)	Twisting moment (N.m)
∅ 6	15-20
∅ 9.52	35-40
∅ 16	60-65
∅ 12	45-50
∅ 19	70-75

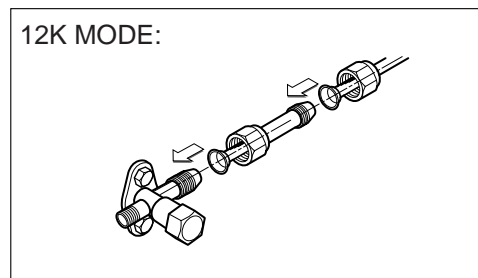

12K unit need to be installed the indoor unit ∅12 connection pipe with the "conversion joint"

12K MODE:



MAINTENANCE



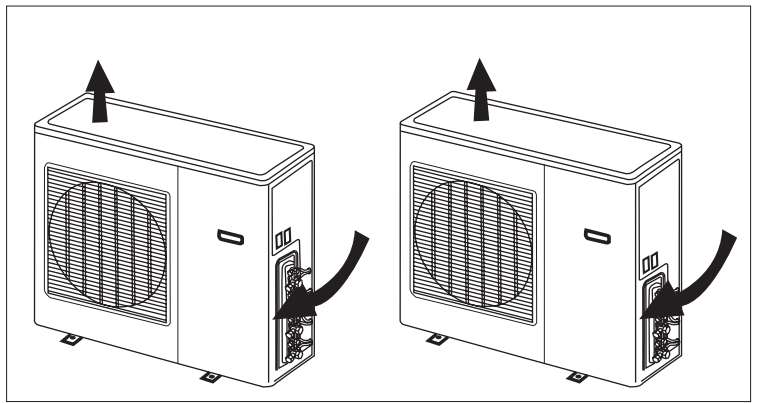

INSTALLER

-  Use suitable instruments for the refrigerant R410A.
-  Do not use any other refrigerant than R410A.
-  Do not use mineral oils to clean the unit.



INSTALLATION DIMENSION DIAGRAM

INSTALLER

-  The installation must be done by trained and qualified service personnel with reliability according to this manual.
-  Contact service center before installation to avoid the malfunction due to unprofessional installation.
-  When picking up and moving the units, you must be guided by trained and qualified person.
-  Ensure that the recommended space is left around the appliance.

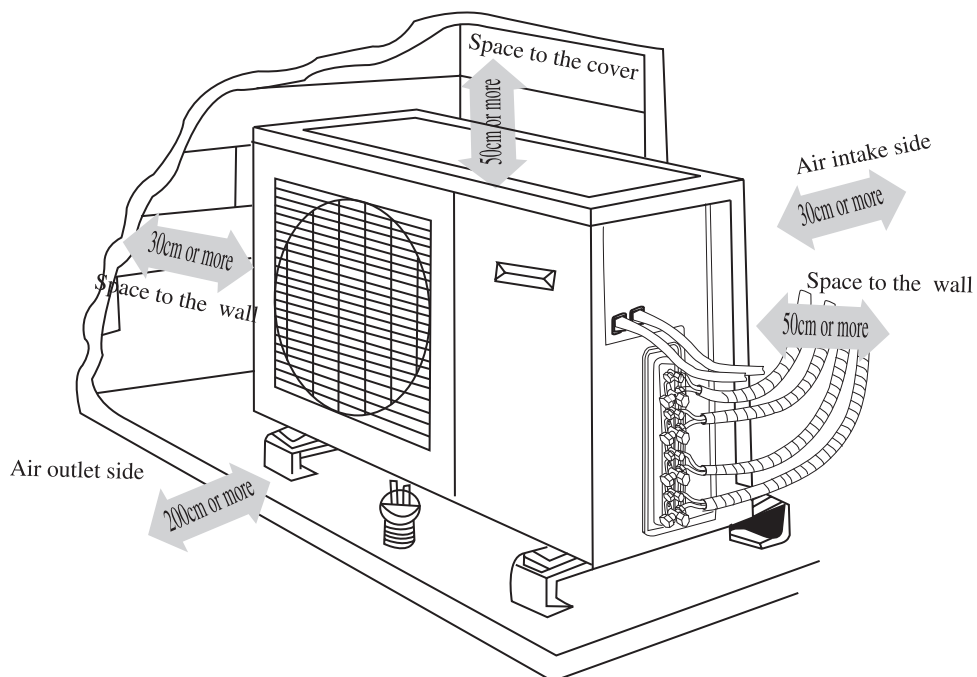

Check Items	Problems Owing to Improper Installation
Is the installation reliable?	The unit may drop, vibrate or make noises
Has the gas leakage been checked?	May cause unsatisfactory cooling (heating) effect
Is the thermal insulation of the unit sufficient?	May cause condensation and water dropping
Is the drainage smooth?	May cause condensation and water dropping
Does the power supply voltage accord with the rated voltage specified on the nameplate?	The unit may bread down or the components may be burned out
Are the lines and pipelines correctly installed?	The unit may bread down or the components may be burned out
Has the unit been safely grounded?	Risk of electrical leakage
Are the models of lines in conformity with requirements?	The unit may bread down or the components may be burned out
Are there any obstacles near the air inlet and outlet of the indoor and outdoor units?	The unit may bread down or the components may be burned out
Have the length of refrigerating pipe and refrigerant charge amount been recorded?	It is not easy to decide the charge amount of refrigerant.

D101	Meaning	D102	Meaning	D103	Meaning
Blink once	Compressor operates	Blink once	Air exhaust protection frequency reducing	Blink once	Air exhaust protection frequency limit
Twice	Compressor high pressure protection unit stop	Twice	Cooling overload frequency reducing	Twice	Cooling overload frequency limit
Three times	Air exhaust protection unit stop	Three times	Over current protection frequency reducing	Three times	Over current protection frequency limit
Four times	Communication malfunction unit stop (Include indoor unit and driver)	Four times	Phase current protection frequency reducing	Four times	Phase current protection frequency limit
Five times	IPM modular protection unit stop	Five times	Heating A unit anti-high temperature frequency reducing	Five times	Heating A unit anti-high temperature frequency limit
Six times	Over current protection unit stop	Six times	Heating B unit anti-high temperature frequency reducing	Six times	Heating B unit anti-high temperature frequency limit
Seven times	Cooling overload unit stop	Seven times	Heating C unit anti-high temperature frequency reducing	Seven times	Heating C unit anti-high temperature frequency limit
Eight times	Each indoor unit starts heating at same time anti-high temperature protection unit stop	Eight times	Heating D unit anti-high temperature frequency reducing	Eight times	Heating D unit anti-high temperature frequency limit
Nine times	Each indoor unit anti-freezing protection at same time unit stop	Nine times	Defrosting	Nine times	Oil return
Ten times	Outdoor unit temp. sensor malfunction or each indoor unit temp. sensor malfunction unit stop				
Eleven times	Compressor overload protection unit stop				
Twelve times	Compressor low-pressure protection unit stop (preserved)				
Thirteen times	Phase current protection unit stop				
Fourteen times	E2 PROM Error unit stop				
Fifteen times	DC power supply short circuit				
D104	Meaning	D105	Meaning	D106	Meaning
Blink once	Outdoor ambient temp. sensor malfunction	Blink once	A unit communication malfunction (cannot receive correct data within 3mins.)	Blink once	B unit communication malfunction (cannot receive correct data within 3mins.)
Twice	Outdoor tube temp. sensor malfunction	Twice	A unit indoor middle temp. sensor malfunction	Twice	B unit indoor middle temp. sensor malfunction
Three times	Outdoor air exhaust temp. sensor malfunction	Three times	A unit indoor outlet pipe temp. sensor malfunction	Three times	B unit indoor outlet pipe temp. sensor malfunction
Four times	Communication malfunction with driver (cannot receive correct data from driver within 10s)	Four times	A unit indoor inlet pipe temp. sensor malfunction	Four times	B unit indoor inlet pipe temp. sensor malfunction
		Five times	A unit indoor ambient temp. sensor malfunction	Five times	B unit indoor ambient temp. sensor malfunction
		Six times	A unit modes conflict	Six times	B unit modes conflict
		Seven times	A unit anti-freezing protection	Seven times	B unit anti-freezing protection
		Eight times	A unit anti-high temp. protection	Eight times	B unit anti-high temp. protection
D107		D108		D109	Meaning
Blink once	C unit communication malfunction (cannot receive correct data within 3mins.)	Blink once	D unit communication malfunction (cannot receive correct data within 3mins.)		Received communication data proof test correct will flash once
Twice	C unit indoor middle temp. sensor malfunction	Twice	D unit indoor middle temp. sensor malfunction		
Three times	C unit indoor outlet pipe temp. sensor malfunction	Three times	D unit indoor outlet pipe temp. sensor malfunction		
Four times	C unit indoor inlet pipe temp. sensor malfunction	Four times	D unit indoor inlet pipe temp. sensor malfunction		
Five times	C unit indoor ambient temp. sensor malfunction	Five times	D unit indoor ambient temp. sensor malfunction		
Six times	C unit modes conflict	Six times	D unit modes conflict		
Seven times	C unit anti-freezing protection	Seven times	D unit anti-freezing protection		
Eight times	C unit anti-high temp. protection	Eight times	D unit anti-high temp. protection		

24K Free Match outdoor unit GWHD (24) NK3C0									
One unit	Two units			Three units					
7K	7K+7K	9K+9K	12K+12K	7K+7K+7K	7K+9K+9K	9K+9K+9K			
9K	7K+9K	9K+12K		7K+7K+9K	7K+9K+12K	9K+9K+12K			
12K	7K+12K			7K+7K+12K	7K+12K+12K	9K+12K+12K			
28K Free Match outdoor unit GWHD (28) NK3A0									
One unit	Two units			Three units			Four units		
7K	7K+7K	9K+9K	12K+12K	7K+7K+7K	7K+9K+9K	9K+9K+9K	7K+7K+7K+7K	7K+7K+9K+9K	7K+7K+12K+12K
9K	7K+9K	9K+12K		7K+7K+9K	7K+9K+12K	9K+9K+12K	7K+7K+7K+9K	7K+7K+9K+12K	7K+9K+9K+9K
12K	7K+12K			7K+7K+12K	7K+12K+12K	9K+12K+12K	7K+7K+7K+12K	7K+9K+12K+12K	9K+9K+9K+9K
								7K+9K+9K+12K	9K+9K+9K+12K
<p>Note:</p> <p>1. When installing 12K outdoor unit, the "conversion joint" should be adopted and connected with outdoor unit's valve.</p> <p>2. When the indoor unit rated total capacity has exceeded the outdoor rated capacity that will not guarantee the real running capacity of each indoor unit could reach their rated capacity value which is required.</p>									