



Central Air Conditioner

Luxury digital LCD controller WK-010PA-K

Instruction

GREE ELECTRIC APPLIANCES, INC. OF ZHUHAI

Content

1. Introduction to installation.....	2
1.1 Installation of display panel	2
1.2 Installation of electric box.....	3
2. Wiring diagram.....	5
3. Luxury digital LCD controller operation	6
3.1 ON/OFF.....	6
3.2 Timer setting.....	7
3.3 Sleep Setting.....	7
3.4 Fan speed control.....	8
3.5 Temp. setting	8
3.6 Mode Setting	8
3.7 Malfunction display of temp. sensor	9
4. Operation for Remote Controller (Optional Parts).....	10
4.1 Name and function of each button	10
4.2 Operation for cooling.....	12
4.3 Operation for heating	12
4.4 Operation for drying	12
4.5 Operation for fan	12
4.6 Installation of batteries.....	12

1. Introduction to installation

1.1 Installation of display panel

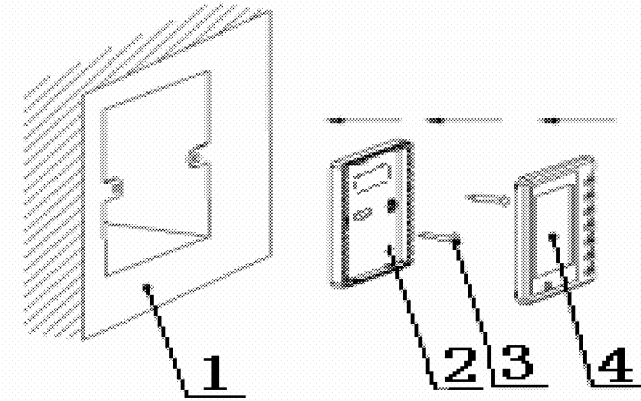

Fig.1 Installation sketch map of controller

- 1) Take out the 2 installation bolts at the bottom of controller panel, and fix the installation plate on wall box;
- 2) Connect all the wiring.
- 3) Assembly the 2 rods on the 2 holes, and cover panel, as shown in fig.(1)

No.	Name
1	86 wall box
2	Controller chassis
3	Bolt M4×25
4	Controller panel

1.2 Installation of electric box

1) The outline dimension of electric box

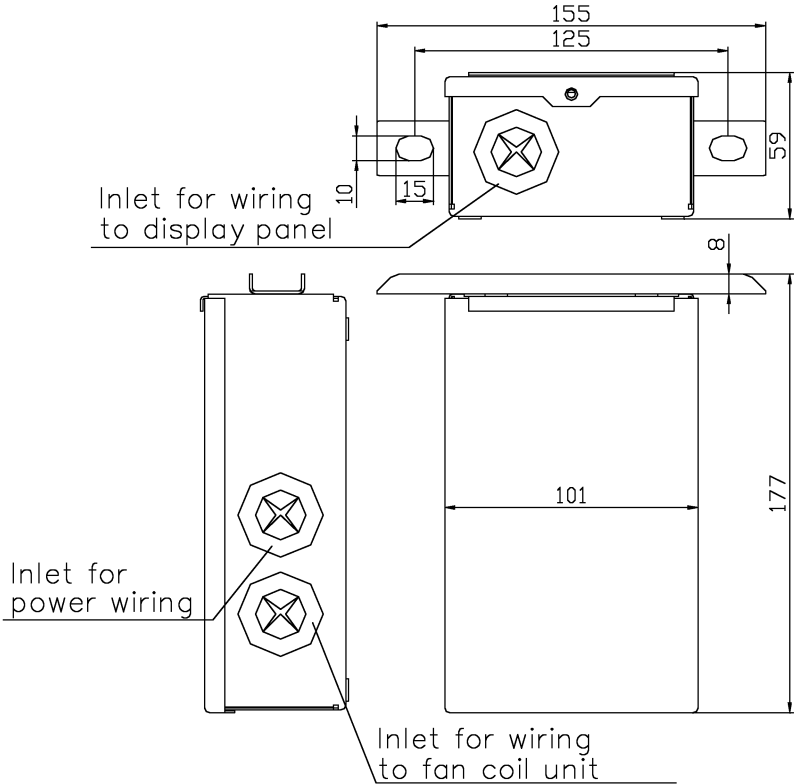

2) Installation of electric box

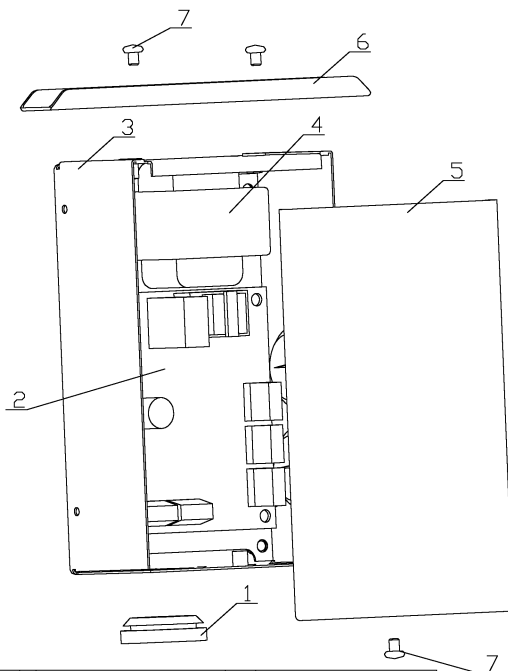

1	Wiring rubber loop	5	Electric box cover
2	Main board	6	Frame
3	Electric box soleplate	7	Bolt M4X6
4	Power transformer		

- ❖ When the electric box leaves factory, the parts (No.1-5) has been composed the main body of electric box, so when you install it, you only need connect the frame (No. 6) and main body with bolts.
- ❖ When connect wiring, loosen the bolt M4X6 at the bottom of electric box, take away the cover. After the wiring connection, make sure to put the cover.
- ❖ When you install the electric box, you need install two suspenders on the ceiling; its distance is the same to that between two holes (10*15) at the middle of frame.

2. Wiring diagram

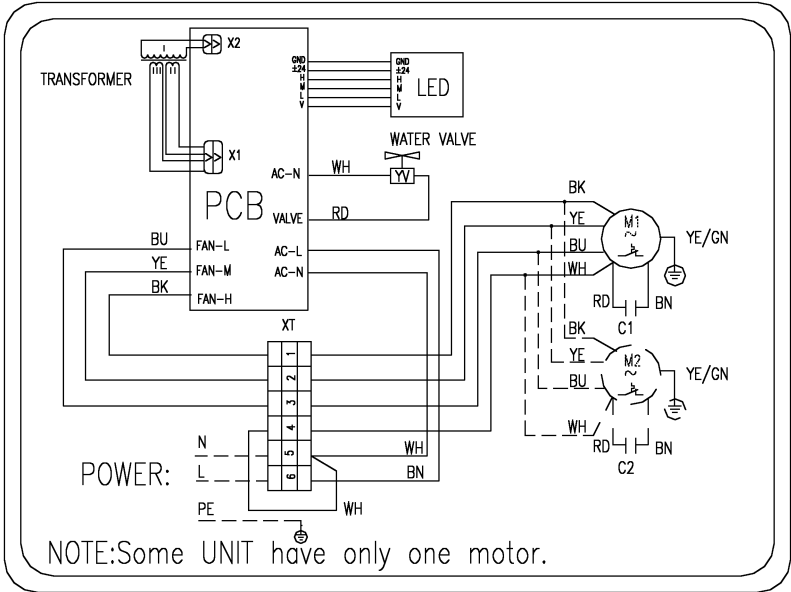

Fig.2 Wiring diagram

According to wiring diagram, connect the wiring between main board of controller and fan coil unit; between main board of controller and display panel. Before turn on the power, please check whether the wiring connection is correct.

Notice:

- 1) Don not install the display panel at the place with water leakage or have sun shine directly.
- 2) Don not knock or throw or assembly and disassembly the display panel frequently;
- 3) Please cut off the power before installation or maintenance.

3. Luxury digital LCD controller operation

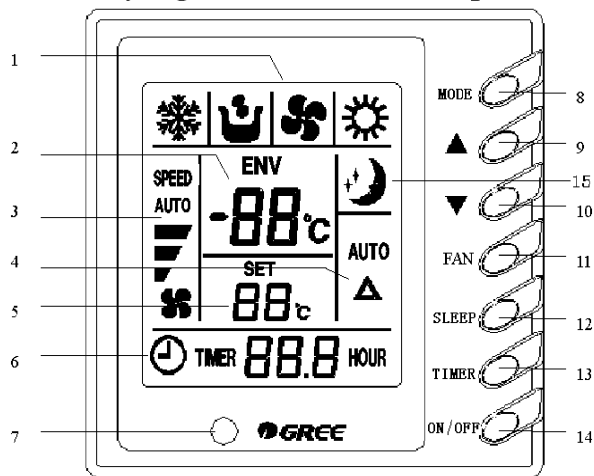

Fig.3 Outline of controller panel

STRUCTURE OF EACH PARTS			
1	Mode display	8	Mode button
2	Ambient temp. or malfunction code display	9	Temp/timer + button
3	Fan speed display	10	Temp/timer-button
4	Auto mode display (reserved)	11	FAN SPEED button
5	Setting temp. display	12	SLEEP button
6	Timer display	13	TIMER button
7	Signal transmitter	14	ON/OFF button
		15	Sleep display

3.1 ON/OFF



- ❖ Press “ON/OFF” button this unit will start working.
- ❖ Press “ON/OFF” button again, this unit will stop working.

Notice: Once the power supply is available, the LCD will display the environment temp. both under ON and OFF state.

3.2 Timer setting

- ❖ Starting time can be set in OFF mode and stopping time can be set in ON mode.
- ❖ Under the status of no timer setting(no display in Timer display region), if press TIMER button, the icon of “TIMERx.xHOURL” will be displayed on the LCD(hereinto, “x.x”is the last setting time),and the time numbers will flicker in a 0.5- second cycle, which indicates timer can be set by pressing “▲”or “▼”button. After setting the time, time numbers stop flickering by pressingTIMER button again, which indicates the timer setting has been finished. If TIMER button hasn’t been pressed again yet within 10S when timer numbers is flickering, there will be no display on the LCD and timer setting is failed.
- ❖ Under the status of that Timer has been set (time numbers are static), if press TIMER button again, there will be no display about timer on the LCD, which indicates the last timer setting has been canceled.
- ❖ Press TIMER button to set timer, the range of set time is 0.5h~24h. Press ▲ button (or the ▼ button)once, set time will be raised (or reduced) by 0.5h, then press TIMER button again to confirm. The range of adjustment by “▲” and “▼” is 0 to 24h, and it can be adjusted in recurrence.

3.3 Sleep Setting

- ❖ In COOL, DRY or HEAT mode, press SLEEP button to start this function, press this button again to quit the function.
- ❖ When this function is set, the sleep icon  will be displayed. After the function is off, the icon will disappear.
- ❖ In COOL or DRY mode, press SLEEP button, the previous temp. will be increased by 1°C in 1h ,and another 1°C increased in 2h,then the icon disappears, and the unit will  continue to run at this setting temp. in

corresponding mode.

- ❖ In HEAT mode, press SLEEP button, the previous temp. will be decreased by 1°C in 1h ,and another 1°C decreased in 2h,then the icon disappears, and the unit will continue to run at this setting temp in HEAT mode.
- ❖ In FAN mode, there is no sleep function.
- ❖ In each mode, the range of the setting temp will never exceed 16°C~30°C.

3.4 Fan speed control

- ❖ Every press of FAN SPEED button , the fan speed will be changed as follows:

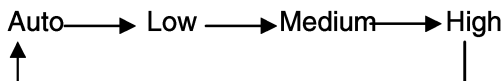

- ❖ In DRY MODE: the fan speed of the unit will be automatically set to be low by the terminals.

3.5 Temp. setting

- ❖ No for time setting, press “▲” or “▼” button to adjust the temp.

▲: For increasing the temp. by 1°C

▼: For decreasing the temp. by 1°C

- ❖ Temp. setting range in each mode:

HEAT ----- 16°C~30°C

COOL ----- 16°C~30°C





DRY ----- 16°C~30°C

FAN ----- Temp. can not be set, which is defaulted to be 24°C.

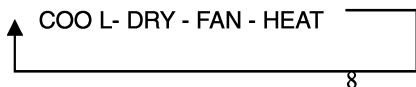
3.6 Mode Setting

- ❖ Every press of MODE button, the operation of mode will be changed orderly as below:



- ❖ In COOL mode, the icon  will light on, in which case, setting temp. must be set to be lower than that of ambient temp. , otherwise, the terminals will not enter cool mode.
- ❖ In DRY mode, the icon  will light on. The fan motor will run at low speed in certain range. The dehumidification effect in this mode is better than that in cool mode, furthermore, better energy saving.
- ❖ In HEAT mode, the icon  will light on, in which case, setting temp. must be set to be higher than that of ambient temp. , otherwise, the terminals won't enter heat mode.
- ❖ In FAN mode, the icon  will light on

3.7 Malfunction display of temp. sensor

- ❖ If malfunction of indoor temp. sensor happens, F0 will be displayed in ambient temp.display region.
- ❖ If terminals controller displays malfunction, stop the unit and ask maintenance personnel for help.

4. Operation for Remote Controller (Optional Parts)

4.1 Name and function of each button

Note:

- ❖ This type of remote controller is a kind of current controller. Some buttons of the controller which are not available to this air conditioner will not be described.
- ❖ Make sure there is no obstruction between remote controller and signal receiving window.
- ❖ The receiving distance of remote controller can reach about 8m.
- ❖ Do not drop or throw the remote controller.
- ❖ Do not let any liquid flow into remote controller, or expose the remote controller under direct sunshine or extreme hot temperature.

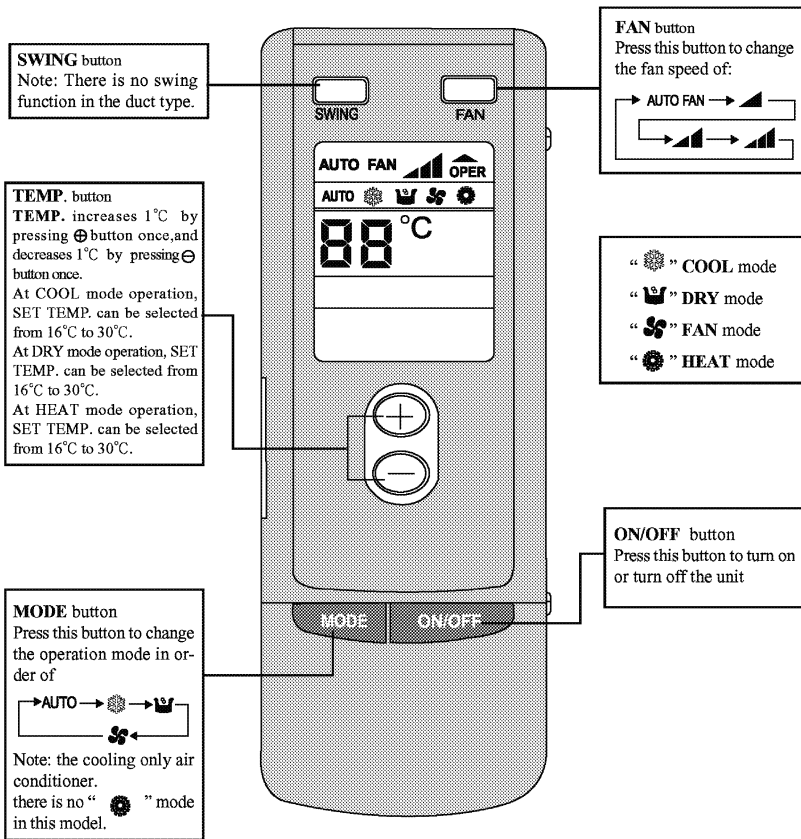



Fig.4

4.2 Operation for cooling

Powering the unit on, press ON/OFF button, then press MODE button to select the icon  for cooling, at last adjust the setting temp. by pressing +or - button.

4.3 Operation for heating

Powering the unit on, press ON/OFF button, then press MODE button to select the icon  for heating, at last adjust the setting temp. by pressing +or - button.

4.4 Operation for drying

Powering the unit on, press ON/OFF button, then press MODE button to select the icon  for drying, at last adjust the setting temp. by pressing +or -button.

4.5 Operation for fan

Powering the unit on, press ON/OFF button, then press MODE button to select the icon  for fan, in which case, the unit will run in FAN mode, and three-level fan speed, high ,medium and low, can be adjusted by pressing FAN button.

4.6 Installation of batteries

Refer to Fig.5 about the details.

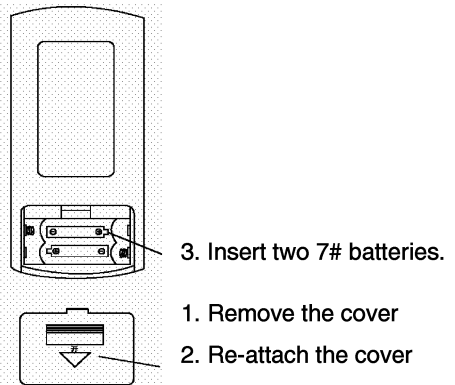

Fig.5 Replacement of batteries

- ❖ The remote controller will can be used after being installed with batteries and displaying all icons of functions and letter codes.
- ❖ About one-year lifetime of the batteries.
- ❖ Don't mix new and used or different types of batteries.
- ❖ Remove batteries away when the remote controller is not in use for a long time.

GREE ELECTRIC APPLIANCES, INC.OF ZHUHAI

Address: Jinji West Road, Qianshan, Zhuhai, Guangdong

Tel: (0756) **8617555**

(Customer Inquiry Service Center)

Postcode: 519070

66170013